

# Pro Audio

Computer Audio  
Pro Recording  
Live Sound/PA  
Installation Sound  
Broadcast/ENG



Summer 2008

#### HOURS OF OPERATION:

Sunday: 10:00am – 5:00pm

Monday thru Thursday: 9:00am – 7:00pm

Friday: 9:00am – 2:00pm Saturday: Closed

**FREE SHIPPING**  
on most items  
(some restrictions may apply)

800-416-5090 | 212-502-

420 Ninth Avenue, New York, NY 10001 | [www.bhproaudio.com](http://www.bhproaudio.com)

### Hours of Operation:

Sunday: 10:00am – 5:00pm  
Monday thru Thursday: 9:00am – 7:00pm  
Friday: 9:00am – 2:00pm Saturday: Closed

### Holiday Schedule:

Monday-Tuesday June 9-10, 2008 — Closed  
Sunday, August 10, 2008 — Closed  
Tuesday-Wednesday, Sep. 30 - Oct 1, 2008 — Closed  
Wednesday-Thursday, Oct. 8-9, 2008 — Closed  
Tuesday-Wednesday, Oct. 14-22, 2008 — Closed  
Thursday, December 25, 2008 — Closed



With such a wealth of high-quality gear enriching the market each year, there has never been a better time to take advantage of the advances being made in almost every aspect of the Pro Audio field. Faster processors, lighter materials, and new innovations combined with time-honored techniques have led to the development of a whole new generation of exciting products designed to increase your work flow and greatly improve your final results.

Our knowledgeable sales staff is at the forefront of these fast-paced industry changes and is here to provide you with a great resource of both technical information and practical knowledge to help you make the most informed equipment selections possible. With our newly expanded retail space continually developing, this year will see even more pro gear on display to complement our already successful microphone/preamp demo booth. Whether you are browsing our web page, speaking to one of our informed phone associates, or visiting our store, you are assured a truly professional sales experience.

## Pro Audio at The Professional's Source [www.bhproaudio.com](http://www.bhproaudio.com)



### Sign Up for our Pro Audio E-mail Newsletter

Written by our professional staff, our monthly Pro Audio Update includes: Informative Guides, Industry News, Tips & Tricks, and exciting new Product Information



Sign up: [www.bhphoto.com/subscribe](http://www.bhphoto.com/subscribe)

## TABLE OF CONTENTS

### PRO RECORDING / COMPUTER AUDIO 4–175

Large Diaphragm Microphones	4–13
Ribbon Microphones	14–15
Small Diaphragm Microphones	16–21
USB Microphones	22–23
Channel Strips/Mic Preamps	24–33
Cassette/Digital Recorders	34–35
CD Players/MP3 Players	36–37
Professional CD Recorders	38–39
Professional CD/Tape Decks	40–41
Effects Processors	42–47
Compressors/Dynamics Processors	48–51
Equalizers/Feedback Suppressors	52–55
Guitar Solutions	56–57
Stand-Alone Digital Workstations	58–61
A/D-DA Converters	62–64
Format Converters	65
Clocks/ Synchronizers	66
MIDI Interfaces	67
Computer Audio Interfaces	68–81
Computer Audio Software	82–89
Software/Plug-ins	90–91
Computer Audio Plug-Ins	92–101
Virtual Instruments	102–117
Podcasting Production	118–119
USB/MIDI Controllers	120–128
Footswitches & Pedals	129
Drum Machines/Drum Pads	130–131
Sampler/Sequencer Workstations	132–133
Synthesizer Workstations/Modules	134–145
Digital Pianos	146–149
Arrangers/Portable Keyboards	150–153
Synthesizer Expansion Boards	154
Keyboard Amplifiers	155
Master Controllers/ Routers	156–157
Headphone Amplifiers	158–159
Headphones	160–163
Studio Monitors & Subwoofers	164–175

### BROADCAST / ENG 176–197

Broadcast Studio Microphones	176
Stereo Microphones	177
Shotgun Microphones	178–183
Lavalier Microphones	184–185
Handheld ENG Microphones	186–187
Portable Field Mixers	188–191
Portable Field Recorders	192–197

### WIRELESS 198–225

Portable Wireless Systems	198–203
---------------------------	---------

ENG Kits	204–205
Wireless Microphones/In Ear	206–215
Wireless Antennas & Antenna Distribution	216–221
Classroom Assitive Listening	222–225

### LIVE SOUND / PA 226–299

Handheld Performance Microphones	226–233
Instrument Performance Microphones	234–237
Clip-On Microphones	238–239
Drum Microphone Kits	240–241
Podium/Gooseneck Microphones	242–243
Boundary/PZM Microphones	244–245
Hanging Microphones	246–247
Headset Microphones	248–249
Analog Mixers	250–257
Digital Mixers/Firewire Optional Mixers	258–259
DJ-Turntables	260–261
DJ-CD/DVD Players	262–263
DJ-Hard Disk Systems & Kits	264
DJ-Mixers & Effects	265–268
DJ-Computer DJ	269–271
DJ-Accessories	272
DJ-Cases & Accessories	273–275
Crossovers & System Processors	276–279
Power Amplifiers	280–285
Portable PA	286–291
Powered PA Mixers	292
PA Kits	293
Powered PA/SR Speakers	294–295
Passive PA/SR Speakers	296–297
PA/SR Subwoofers	298–299

### INSTALLATION SOUND 300–335

Install Mixers & Routers	300–305
Zone Mixers	306–307
Distributed Amplification	308–316
Installation System Processors	317
Distribution Amplifiers	318–319
Surface Mount Speakers	320–325
Ceiling Mount Speakers	326–329
Analyzers & Metering	330–331
Installation Accessories	332–333
Lecterns/Podiums	334–335

### PRO SHOP ACCESSORIES 336–415

Power Distribution & Conditioners	336–339
Direct Boxes	340–343
Phantom Power/Hum Eliminators	344–346
Level Matching	347–348

Cable Testers	349
Inline Problem Solvers	350
Audio Adapters & Y Cables	351
Pop Filters	352
Windscreens	353
Microphone Clips & Mounts	354
Microphone Mounts & Fittings	355
Microphone Mounts & Desktop Stands	356
Goosenecks & Boom Arms	357
Stands & Benches	358–363
Studio Monitor Stands	364
Speaker Mounting Hardware	365
Boom Poles	366
Boom Pole Accessories	367
Broadcast Accessories	368–374
IFB/Communication	375
Communication	376
Distribution & Communication	377
Snakes & Stage Boxes	378–379
Hosa Cables	380
Monster Cable	381
Pro Co Sound Cables	382
Cables	383
Comprehensive Cables	384
Media	385
PA Accessories	386–387
General Accessories	388
Metronomes & Tuners	389
Road Cases & Racks	390–405
Studio Furniture	406–407
Rack Drawers & Shelves	408
Rack Shelves & Panels	409
Acoustic Treatment	410–415

### COMPUTERS & TUTORIALS 416–437

Apple Computers	416–417
PC Computers	418–419
External Hard Drives	420–421
DVD/CD Duplicators	422
LCD Monitors	423
Hubs & Peripherals	424
UPS/Battery Back up	425
Books/Tutorials	426–431
Sound Effects Libraries	432–433
Sample Content	434–437

### INDEX / ORDER FORM 438–445

Index	438–444
Order Form	445

▶ **Free Shipping on most items over \$199**  
some restrictions may apply

▶ **Free 1 Hour Parking**  
for B&H customers at  
349 W 34th Street

▶ **Equipment Leasing Available**

▶ **We Buy, Sell & Trade Used Equipment**

▶ **Most Orders Shipped within 24 hours**  
Overnight Service Available



**Customer Service Numbers**  
800-221-5743 • 212-239-7765

**Fax Numbers**  
800-947-2215 • 212-239-7549



## BLUE BLUEBERRY

The Blueberry is a unique, precision-engineered, large diaphragm cardioid condenser microphone with an open natural response tailored especially for vocals. Its hand-built capsule and discrete low-noise circuitry provides the shimmering detailed highs, smooth mids, and articulated low end desired by professional musicians and engineers.

- Outstanding for vocal, voice-over, and acoustic instrument recordings.
- Custom-designed and hand-built components
- Excellent low-level presence
- Extremely well-balanced response characteristics
- Discrete Class-A circuitry for low-noise handling
- 133dB SPL • 20Hz-20kHz frequency response
- Cherry-wood case included



#BLBM  
**\$999<sup>00</sup>**

## RODE NT2000



The RODE NT2000 is the world's first continuously variable control microphone. Its polar response, filter adjustments, and pad attenuation greatly enhance overall control and performance flexibility, while the newly-designed capsule diaphragm provides the warm, detailed sound and excellent transient response necessary for a variety of recording applications.

- Large diaphragm condenser mic with variable polar, pad, and filter controls
- Very wide dynamic range for multiple recording applications
- Active electronics with FET impedance converter
- 147dB SPL
- 20Hz-20kHz frequency response
- Shock mount and molded case included

#RONT2000  
**\$599<sup>00</sup>**

## NEUMANN TLM103A

Derived from the famous U87, the affordable TLM103A (anniversary edition) is a large diaphragm, cardioid condenser microphone. Its well-balanced performance and extremely low self noise make it the mic of choice for virtually all recording, broadcast, and production applications.

- Excellent noise rejection
- Internal shock mount reduces handling noise
- Transparent audio reproduction
- 138dB SPL
- 20Hz-20kHz frequency response
- Aluminum case (included)



#NETLM103A  
**\$1299<sup>00</sup>**



## SHURE KSM32SL

Ideal for both studio and live sound applications, the Shure KSM32 is a ruggedly built, large diaphragm cardioid condenser microphone. Its Class-A circuitry and extended "sweet spot" delivers a smooth, detailed response, making it well-suited for recording sources from piano to percussion or violin to vocals.

- Built-in pop filter
- Switchable low-frequency filter
- 48V phantom powered
- 15dB pad
- 139dB SPL
- 20Hz-20kHz frequency response

#SHKSM32SL  
**\$549<sup>00</sup>**

## CAD E1002

The CAD Equitek E1002 is a high-quality supercardioid electret condenser microphone designed with unique servo-controlled circuitry that supplies the additional power needed for capturing even the most demanding sound sources with remarkable transparency and detail.

- Ideal for multiple recording purposes, especially kick drum, guitar amps, and vocals
- Unique servo design incorporates both internal batteries and external 48V phantom power to enhance performance
- Transformerless design for lower noise
- 148dB SPL (with 20dB pad engaged)
- 10Hz-18kHz frequency response



#CAE1002  
**\$249<sup>99</sup>**



**STUDIO PROJECTS****C1**#STC1Q  
**\$239<sup>99</sup>**

The Studio Projects C1 is an extremely versatile large diaphragm cardioid condenser microphone with a rich, smooth tone and open, detailed response. It clearly represents a breakthrough for both project and professional studios in search of a high-quality microphone at an affordable price.

- Ideal for vocals and acoustic instruments
- Transformerless low-noise design
- 10dB pad with high-pass filter
- 142dB SPL
- 20Hz-20kHz frequency response
- Case, shock-mount and windscreen included

**AUDIO TECHNICA**  
**AT4050**#AUAT4050  
**\$599<sup>00</sup>**

The AT4050 is a multi-pattern condenser microphone designed to provide years of high-quality performance in any recording environment. Its transformerless design and "extended life" dual-diaphragm capsule produces a warm detailed response with virtually no low-end distortion.

- Switchable Cardioid, Omni, and Figure-of-Eight patterns
- Gold diaphragm aging process for extended performance life
- Transparent upper and mid-range frequencies
- Switchable high-pass filter with 10dB pad
- 149dB SPL
- 20Hz-18kHz frequency response

**AKG**  
**C3000B**#AKC3000B  
**\$349<sup>00</sup>**

The AKG C3000 B is a large diaphragm cardioid condenser microphone built for both studio and live performance use. Its special capsule tuning allows a pleasing, smooth sound with a slight presence boost to add "air" to both vocal and instrument recordings. Capable of handling very high source levels without clipping, the C3000 B effectively reduces unwanted noise while providing the signal-to-noise ratio needed by project studio engineers who want "present" and "up-front" takes.

- Ideal for lead vocals and high-volume instrument sources such as guitar amps, brass, and percussion
- Clean, transformerless design with smooth, wide dynamic range
- Internal and external "spider" suspension for increased noise reduction
- Smooth low-frequency roll-off and 10dB pad
- 150dB SPL (pad engaged)
- 20Hz-20kHz frequency response

**AKG****C414 B-XL II**#AKC414BXL2  
**\$999<sup>00</sup>**

The AKG C414 B-XL II is the next generation of legendary C414 microphones. With improved electronics and greater versatility, the XL-II sets a new benchmark for all other studio microphones.

- High sensitivity and extremely low self noise
- Five switchable polar patterns for placement and application flexibility
- Unique elastic capsule suspension greatly minimizes noise from chassis vibration
- Two-color LED's provide quick visual indication of selected polar pattern and output overload
- 20Hz-20kHz frequency response
- Professional shock mount, pop filter and windscreen provided

**BLUE****Baby Bottle**  
**with Shock-Pop**#BLBBMSP  
**\$499<sup>00</sup>**

Using design elements of the acclaimed Bottle mic system, the Baby Bottle is a solid-state, Class-A discrete condenser microphone that employs the styling, attention to detail, and hand-crafted quality Blue is famous for. The precision-machined, gold-sputtered capsule has a fixed cardioid pattern and is enclosed in a "Lollipop" spherical grille. The versatile Baby Bottle

has a high output level with low self noise, providing a natural, uncolored response that's particularly effective for vocals, acoustic instruments, and hand percussion.

- Solid-state, Class-A discrete circuitry
- High sensitivity and extremely low self noise
- Tailored frequency response for improved vocal presence
- 133dB SPL • 20Hz-20kHz frequency response
- Includes: Shock mount and pop filter, protective pouch, cherrywood box



## NEUMANN U87AI/SET Z

The legendary U87, known for its warm, rich sound, and precision engineering, is perhaps the world's most widely used large diaphragm condenser studio microphone. When making a professional studio investment, it's considered the piece to buy.

- Its sound has made it a favorite on vocal, string and piano recordings for years
- Multiple selectable patterns for recording flexibility
- Improved sensitivity for better signal-to-noise ratio than original U87
- Transformerless design for ultra-low noise operation
- 10dB pad
- 117dB SPL
- 20Hz-20kHz frequency response



#NEU87AISZ  
**\$3199<sup>99</sup>**

## SE ELECTRONICS SE2200A

With lower noise electronics and a better signal-to-noise ratio, the Studio Electronics SE2200A is an affordable large diaphragm cardioid condenser microphone that improves upon its already well-received predecessor, the SE2200. Featuring a clear and lively sound that's slightly "lifted" (bright) in the upper range, the SE2200A delivers the characteristic response needed by both project and professional studios searching for uncolored vocal and acoustic instrument recordings that are both "up front" and "present" in the mix.

- Transformerless FET circuit for a clean, transparent tone quality
- Slight high-frequency boost tailored to enhance vocal response
- 10dB pad and 100Hz low-cut filter
- 125dB SPL
- 20Hz-20kHz frequency response
- Includes rugged aluminum shock mount and flight case



#SESE2200A  
**\$299<sup>00</sup>**

## RODE NT2A



The RODE NT2A is a high-quality, large dual-diaphragm multi-pattern condenser microphone, with superior electronics that provide ultra-low noise performance. Its fixed variable pad, pattern and filter adjustments provide the flexibility and control needed by musicians and recording engineers.

- Variable Pad, Pattern, and Filter adjustments made from the mic
- Acoustically-modeled solid cast metal housing
- Polar patterns include: Cardioid, Omni, and Figure 8
- High-strength steel mesh head
- Internal capsule shock mounting
- 157dB SPL (pad engaged)
- 20Hz-20kHz frequency response

#RONT2A  
**\$399<sup>00</sup>**



## AUDIO TECHNICA AT4040

The Audio-Technica AT4040 is a large diaphragm cardioid condenser microphone designed to offer full-range detail at an affordable price. Providing improved electronics and a transformerless design, the character of the AT4040 is full and round with the transient response and high source level handling capabilities needed for all-around source-capturing capabilities. A perfect do-it-all first mic for project studios, the AT4040 delivers the performance of microphones costing significantly more.

- Full, detailed sound with enhanced presence for additional "sparkle" and "sheen"
- Sensitive capsule with fast transient response and high volume handling capability
- Ideal all-purpose vocal and instrument microphone
- 80Hz high-pass filter and 10dB pad
- 155dB SPL (pad engaged)
- 20Hz-20kHz frequency response

#AUAT4040  
**\$299<sup>00</sup>**

## M-AUDIO Luna

The unique, sturdy design of the M-Audio Luna makes this quality large diaphragm condenser a versatile microphone for a variety of studio recording applications. The well-built Luna utilizes a large brass capsule and modern Class-A electronics, delivering a flat, smooth sound that accurately represents what you put into it.

- Transparent Class-A design with high sensitivity and lower noise operation
- Well-suited on guitar amps, vocals, and percussion
- Unique, sleek design with sturdy chassis
- 130dB SPL
- 20Hz-20kHz
- Hard case and shock mount included

#MALCM  
**\$249<sup>00</sup>**



**NEUMANN****TLM49**

The TLM49 is a professional large diaphragm cardioid condenser microphone designed to provide vocalists with the smoothest, most natural sound reproduction available. Utilizing its tube simulation circuit, the TLM49 produces even order harmonics in the same way a tube microphone would. Its focused sound is smooth and full with a transparent subtleness that picks up every nuance of a vocalist's performance.

- Designed especially for studio-recorded vocals
- Tube simulation circuitry creates warm, full harmonics
- Cardioid pattern isolates source material while reducing noise
- No additional cabling or power supply necessary
- 127dB SPL • 20Hz-20kHz frequency response

#NETLM49  
**\$1499<sup>00</sup>****BLUE****Joe**

The JOE is a cost-effective, large-diaphragm cardioid condenser microphone designed for home and project studio recording applications. It features a classic look with an anodized finish, and a floating capsule design for the mounting hardware offering flexible positioning options. The Class-A discrete electronics and hand-tuned capsule ensure high value for the modest price.

- Large-diaphragm cardioid condenser microphone for project studios
- Hand-built, hand-tuned capsule
- Class-A discrete amplifier circuit
- Unique swivel mount and velvet carrying bag included

#BLJOE  
**\$299<sup>00</sup>****BEHRINGER****B-2 Pro**

The B-2 Pro is a large diaphragm multi-pattern condenser microphone with features found mostly on more expensive microphones. Combined with its flexible patterns, pad, and filter adjustments, the mic's clarity and slightly enhanced high-end presence provides musicians and engineers with the control and sonic characteristics required for quality recordings at an affordable price.

- Ideal for vocal or multi-purpose instrument recordings
- Transparent low-noise FET circuit design with wide frequency response
- 10dB pad and 150Hz low-cut filter
- 148dB SPL (pad engaged)
- 20Hz-20kHz frequency response
- Heavy-duty suspension mount, windscreen and case included

#BEB2PRO  
**\$149<sup>99</sup>****AUDIO TECHNICA****AT3035**

The Audio-Technica AT3035 is an affordable high-performance large diaphragm condenser microphone. Its crisp, clear highs and robust lows make the versatile AT3035 a great choice for use in project and home studios.

- Wide dynamic range
- Low self noise
- Low-cut switch and 10dB pad
- 148dB SPL
- 20Hz-20kHz frequency response
- Custom shock mount and protective pouch provided

#AUAUT3035  
**\$199<sup>00</sup>****AUDIX****CX-112**

Engineers and musicians alike will appreciate the versatility of the Audix CX-112. This large diaphragm cardioid condenser microphone features a warm, large sound and a durable, high-quality build for both live and studio recordings. Capable of handling high sound pressure levels while still maintaining very low-noise performance, this impressive utilitarian mic provides the airy, open highs and smooth, extended lows associated with condenser mics significantly more expensive.

- Capsule internally shock-mounted on silicon rubber support
- Sturdy, perforated black steel grill provides better transparency and capsule protection
- 10dB pad and bass roll-off filter
- 145dB SPL (pad engaged)
- 20Hz-20kHz frequency response
- Foam-lined rosewood case and hard mount metal stand adapter included

#AUCX112  
**\$399<sup>00</sup>**



**M-AUDIO****Sputnik**

The Sputnik from M-Audio is a large diaphragm vacuum tube microphone that was designed to bring out musical detail in a wide variety of instrumentation and voices. It combines the nuances of classic tube microphones with customized design innovations that result in a stellar sounding workhorse production tool. The carefully conceived circuitry of the power supply protects the tube and allows for cable runs of up to 200'.

- 18dBA of self-noise
- -10dB pad, low-cut filter at 80 Hz
- 3-micron evaporated gold Mylar diaphragm
- Multiple polar patterns, Cardioid, Omni, and Figure-8
- Power supply, 26' 7-pin cable, shockmount, and flightcase included
- 132dB SPL
- 20Hz - 20kHz frequency response

#EASR30  
**\$799<sup>00</sup>****BLUE****BlueBird**

The Bluebird features Class-A discrete circuitry that delivers excellent audio quality on a wide variety of sound sources. Designed with versatility in mind, the Bluebird is popular among project studios who demand outstanding quality at an affordable price. The Bluebird brings out clarity and detail on vocals, guitars, drums, piano, horns, strings, etc. The BirdCage shock mount and BirdNest pop filter are both included.

- Cardioid pick-up pattern
- Workhorse studio microphone for a variety of sounds
- 48V phantom powered
- 138dB SPL
- 20Hz-20kHz frequency response
- Includes custom shock mount and pop filter

#BLBBMQ  
**\$349<sup>00</sup>****CAD****M179**

An ideal multi-purpose studio microphone, the large-diaphragm dual-sided CAD M179 features a continuously variable condenser element that's ideally suited for both vocal and instrument recordings. The improved, sophisticated electronics are capable of capturing complex musical detail with lower noise and better dynamic balance than significantly more expensive microphones. Flexible and versatile, the M179 provides engineers a high-quality microphone for everyday studio use.

- Smooth, continuously variable pattern selection
- Advanced internal amplifier circuit performance that competes with higher-end designs
- Ideal for both solo and ensemble instrument/vocal recordings
- Built-in pad and high-pass filter
- 143dB SPL (pad engaged)
- 10Hz-20kHz frequency response

#CAM179  
**\$199<sup>99</sup>****BLUE****Dragonfly**

The Dragonfly is a cardioid condenser microphone employing Blue's hand-built large diaphragm capsule, discrete Class-A circuitry, and a rotating spherical grille, allowing for an almost infinite number of placements, key for unmatched fine tuning and delivering consistent takes with outstanding depth, definition, and focus. An excellent choice for studio engineers seeking clearly professional results, correct placement of the Dragonfly produces exceptionally focused percussion, instrument, and vocal recordings.

- Unique design with integrated shock mount and spherical grille provides superior versatility, focus, and detail
- Great imaging and slight high-end/low-end boost delivers ideal tone for electric guitar, pop/R&B vocals, and percussion overhead recordings
- Hand-built with high-quality workmanship
- Effectively controls high-volume sources without overload
- 132dB SPL
- 20Hz-20kHz frequency response

#BLDM  
**\$799<sup>00</sup>****SE ELECTRONICS****Z5600A-II**

A multi-pattern tube condenser microphone, the versatile Z5600A-II utilizes a capsule larger than a typical large diaphragm microphone. This unique enlarged design, along with tube circuitry, provides higher sensitivity, better low end, and a warm detailed response, making the Z5600A-II an affordable option with high-performance features. A wooden presentation box, aluminum flight case, shock mount, and power supply with pattern switching and cables are included.

- Multi-pattern tube condenser microphone
- 48V phantom powered
- 9-point selectable polar patterns
- 130dB SPL
- 20Hz-20kHz frequency response
- Warm, detailed tonality especially suited for vocal recordings

#SEZ5600A2  
**\$849<sup>00</sup>**

## AUDIO TECHNICA AT3060

Featuring the warmth of tube technology and articulation similar to small-capsule designs, the AT 3060 is a large diaphragm cardioid tube condenser microphone with a naturally flat, smooth high-end response, ideal for detailed instrument and vocal recordings. Requiring only phantom power and no special external power supply, the AT 3060 makes an ideal choice for on-stage and studio recordings where a well-balanced, detailed tone combined with discrete appearance and convenience is of top priority.

- Ideal for vocal and string instruments producing a warm, well-balanced open response
- Excellent noise rejection due to a tight cardioid pattern and highly-sensitive element
- No dedicated power supply or special cable needed, runs on 48V DC phantom power
- Open acoustic design and internal shock mount for reduced resonance and handling noise
- 134dB SPL
- 50Hz-16kHz frequency

#AUTAT3060  
**\$399<sup>00</sup>**



## AKG Solidtube

Combining the clarity of solid-state power circuitry with the warmth of an all-valve signal path, the AKG Solidtube is a well-built large diaphragm cardioid condenser microphone designed to be a superior vocal and acoustic instrument mic. Providing a well-balanced, smooth sound that could be described as "sweet" and slightly compressed, the Solidtube actually benefits from its proximity effect, producing warm, intimate results without being muddy or uncontrolled.

- Smooth, detailed tone with pleasing full-range balance
- Dual technology design provides lower-noise operation and warm "larger than life" sound
- Ground-lift switch and 100Hz low-cut switch on separate power supply
- 20dB pad
- 145dB SPL (pad engaged)
- 20Hz-20kHz frequency response
- Well-designed shock mount and rugged carrying case included

#AKSOLIDTUBE  
**\$999<sup>00</sup>**



## RODE K2

Combining the sound of vintage tube microphones, the tube condenser RODE K2 produces a smooth, extended high end, fat, round midrange, and solid, full low-end response from its large-diaphragm element. Its continuously variable pattern and high-level handling capability allows the versatile K2 to reproduce sounds from the subtle nuances of finger picking and bowing to thumping guitar amps and booming percussion. In the studio or on stage, the K2 gives musicians and engineers the warm presence and dynamic performance required for truly professional recordings.

- Class-A circuitry with a full, round tone and improved capsule and diaphragm technology
- Multiple recording applications via continuously variable pattern adjustments from Cardioid to Omni to Figure-8
- Extremely high sound pressure level handling capabilities
- 162dB SPL
- 20Hz-20kHz frequency response
- SM2 shock-mount, power supply with 9-pin cable, and hard-shell case included

#ROK2  
**\$699<sup>00</sup>**



## BLUE CACTUS

#BLCM  
**\$2499<sup>00</sup>**

With a warm, wonderful presence and slight mid-range boost, the BLUE Cactus delivers the tonal characteristics required for its specialty—professional lead vocal recordings. This uniquely-designed large diaphragm tube condenser microphone utilizes a multi-pattern version of Blue's hand-crafted and tested B7 capsule and vintage Class-A discrete tube amplifier circuitry. Ideal for high-end studios, the Cactus faithfully reproduces crisp, detailed drums and percussion while maintaining the smooth airy highs and tight full lows desired for a variety of acoustic instrument recordings.

- Remote selectable Cardioid, Omni, and Figure-8 patterns available with variations in between (9 total)
- Tone tailored for vocals, but with the fast transient response and high-end detail required for high-quality percussive and acoustic instrument recordings
- Soft Start feature assures tube longevity and circuit stability
- Transformer designed to match tube for lower noise and superior transparency
- 130dB SPL
- 20Hz-20kHz frequency response
- Includes Series 1 Shock/Pop kit, ATA Flight Case, Champagne Tube Mic Cable, Power Supply



## AKG C12VR

#AKC12VR  
**\$4999<sup>00</sup>**

Legendary for its warmth, clarity, and presence, the meticulously-engineered AKG C12 has been faithfully restored with the C12 VR (Vintage Re-Issue). While maintaining the exact unique twin diaphragm capsule design and 6072A vacuum tube, AKG utilized new manufacturing standards to provide a higher level of consistency and performance for today's high-end digital studios. A most sought after vocal mic, the C12 features multiple polar patterns with six remotely-selectable variations, making it equally desirable for solo and ensemble instrument recordings.

- Vintage re-issue of the famous dual-diaphragm vacuum tube C12
- Multiple patterns (nine total) remotely controlled with silent switching
- Internal microphone switching provided for pre-attenuation of -10dB, -20dB, and 10dB boost
- 128dB SPL
- 30Hz-20kHz frequency response
- Professional flight case, shock mount, and pop filter included



### MXL MXL V69

The MXL V69 is an affordable large diaphragm tube condenser microphone with a wide dynamic range and warm vintage tube sonic characteristics; a perfect complement to digital recording devices. It comes with a deluxe flight case, versatile shock mount, dedicated power supply, Mogami 7-pin and XLR microphone cables and a wind screen.

- Vintage tube sound
- 25mm (1") large capsule condenser • 12 AT7 type tube
- Durable brass enclosure
- 140 dB SPL
- Internally wired and supplied with Mogami cables
- Includes: shock mount, windscreen, power supply, cables, and deluxe flight case
- Frequency response: 20Hz-18kHz



#MXMLV69MEDT  
**\$299<sup>00</sup>**

### ELECTRO VOICE Blue Cardinal

The EV Blue Cardinal is a cardioid condenser microphone designed to capture the detail of both voice and instruments in live sound or studio applications. It features unique cherry wood mic housing, Class A, discrete ultra-low noise amplifier circuitry, and a double swivel-mounted design for flexible capsule positioning.

- Pressure gradient cardioid condenser
- Great for instruments or vocals
- Employs Class A, discrete ultra-low noise amplifier circuitry
- Excellent off-axis rejection
- Stylish cherry wood mic housing
- Unique double swivel-mounted design
- Frequency response: 30Hz-20kHz



#ELCARDINAL  
**\$199<sup>00</sup>**

### MXL MXL V67i



The MXL V67i is a versatile large condenser microphone with 2 selectable diaphragms. The front side has a warm, lush sound, and the microphone's back side simulates some of the brighter more airy sounding vintage capsules of the 1960's. Perfect for those needing several quality microphones, but on a limited budget.

- (2) selectable 25mm/ 1" large capsules (one warm and one bright)
- Solid state preamp with balanced transformer output
- Gold-plated grille
- Selectable pad and roll-off filter • 140dB SPL
- Includes: mic clip and wooden storage case
- Frequency response: 30Hz-20kHz

#MXMLV67I  
**\$149<sup>00</sup>**



### CAD E-300<sup>2</sup>

The E-300<sup>2</sup> is a multi-pattern externally biased servo-condenser great for studio vocals, choir, spoken word, and voice-over applications. The 1.1" 24K gold sputtered externally biased triple pattern (cardioid, omni, figure 8) dual diaphragm condenser capsule is hand-dampened for consistent frequency response. A rechargeable 9V nickel hydride battery provides a huge current reserve, allowing for remote operation for up to 6 hours.

- Multi-pattern externally biased servo-condenser
- Switchable polar pattern: cardioid, omnidirectional, figure 8 • High-pass filter 6dB pad/octave @ 80 Hz • 20 dB pad • 145 SPL
- Includes: shock mount & carrying case
- Frequency response: 10Hz – 20kHz

#CAE300  
**\$399<sup>99</sup>**

### STUDIO PROJECTS

#### B1

The Studio Projects B1 is a versatile cardioid condenser microphone that is equipped with a true one-inch, gold sputtered large diaphragm in a pressure gradient transducer capsule. This versatile mic is great for miking amplifiers with high sound pressure levels, voice over, and a wide variety music and broadcast recording applications.

- Large diaphragm cardioid condenser
- Pressure-gradient transducer, 1" 3 mm mylar capsule
- High-quality transformerless design
- Selectable filters, 75Hz & 150Hz
- Selectable pads, -10dB & -20dB
- Includes: foam wind screen, shock mount, and zippered Bag
- Frequency response: 20-20kHz

#STB1Q  
**\$119<sup>99</sup>**





## RODE NT 1000

The Rode NT 1000 is an ultra-versatile one-inch studio condenser microphone excellent for instrument and overhead drum kit miking. It's built of a heavy-duty cast metal, and the one-inch HF-2 capsule is internally shock-mounted with a 134 dB dynamic range, 140 dB SPL capabilities and a 20Hz to 20kHz frequency response.

- Ultra-versatile studio condenser
- Large capsule with gold-plated membrane
- Low-noise transformerless circuitry
- Internally shock-mounted capsule
- 140 dB SPL
- Heavy-duty cast metal satin nickel body
- Includes: zip pouch and stand mount
- Frequency response: 20Hz-20kHz

#RONT1000  
**\$329<sup>00</sup>**



## M-AUDIO NOVA

The large diaphragm cardioid condenser M-Audio Nova is a cost-effective solution to achieving recording results previously attained by higher cost designs. Class-A electronics and effective source isolation help deliver a smooth, wide frequency response with an improved signal-to-noise ratio, ideal for vocals and other home/project studio recording applications.

- Outstanding value for discrete Class-A circuitry in a large diaphragm condenser mic
- Solid brass capsule
- Wire mesh grille and body, all brass w/silver nickel plating
- 128dB SPL
- 20Hz–18kHz frequency response
- Includes hard mount and soft case
- Also comes with free XLR cable

#MANCM  
**\$99<sup>00</sup>**



## AKG Perception 100

The Perception 100 is a great all-purpose large diaphragm condenser microphone designed for studios and live sound applications. Its one-inch diaphragm cardioid capsule provides a warm, transparent sound, excellent off-axis rejection and high SPL capability. The Perception 100's reliable performance, rugged metal housing and affordable price make it excellent value for project studios.

- Professional general-purpose microphone
- 1" large diaphragm true-condenser capsule
- Cardioid polar pattern
- Rugged metal housing
- Includes metal stand adapter
- SPL 135dB
- Ideal for project studios
- Frequency response: 20Hz- 20kHz

#AKP100  
**\$99<sup>95</sup>**



## AUDIO TECHNICA AT2020

The AT2020 is an affordable cardioid condenser microphone that truly pushes the price/performance envelope. Designed for most home studio recording applications, the AT2020 effectively isolates source

signals while providing a fast transient response and high sound pressure handling capabilities, making it a well-balanced, quality multi-purpose microphone.

- Low-mass diaphragm provides wide dynamic response for multiple recording applications
- Open, acoustic design reduces resonance and handling noise
- Cardioid pattern isolates source signal
- 144dB SPL
- 20Hz-20kHz frequency response

#AUA2020  
**\$99<sup>00</sup>**



## SAMSON CL7

The Samson CL7 is an affordable large diaphragm studio condenser microphone ideal for home studio applications. A great choice for vocals, acoustic instruments, and drums, the CL7 features a large, 1.1-inch, ultra thin diaphragm capsule, a switchable high-pass filter and a 10 dB pad.

- Large diaphragm cardioid condenser
- Internally shock mounted 1.1" capsule
- Switchable high-pass filter, 12dB per octave at 100 Hz
- Switchable 10 dB pad
- Solid die cast construction
- 147 DB SPL
- Includes: swivel stand mount & carrying case
- Frequency response: 20-20kHz

#SACL7  
**\$129<sup>00</sup>**



**CL8 multi pattern condenser #SACL8.....149.00**

**STUDIO PROJECTS****TB1**

The circuit design of this cardioid large diaphragm tube microphone uses as few components as necessary to prevent added noise and coloration. It is powered by a dedicated AC power supply and provides a warm transparent sound that is perfect for both vocals and instruments. The attractive price of the TB1 also makes it a great choice as a stereo pair.

- Large diaphragm cardioid tube microphone
- Great for vocals, overheads and voice-over work
- 128dB SPL handling capability
- 0Hz to 20kHz frequency response
- Includes carrying case and shock mount



#STTB1  
**\$299<sup>00</sup>**

**MXL****MXL-M3**

The M3 Silicon Valve microphone is an all FET design with a warm, transparent sound similar to popular vintage mics of the early 1960's. This attractive microphone is sensitive enough to capture subtle vocal performances and still have enough headroom to capture percussion with detail.

- Cardioid condenser large diaphragm microphone
- Offers smooth vintage sonics
- 130dB SPL handling capability
- 20Hz to 23kHz frequency response
- Includes storage case



#MXMXLM3  
**\$249<sup>00</sup>**

**STUDIO PROJECTS****T3**

The T3 is a variable pattern tube microphone that is designed around the 6072 "dual triode", known for its low noise, sonic characteristics, and reliability. Pattern control is variable between omnidirectional, wide cardioid, cardioid, supercardioid, hypercardioid, and figure of eight via a nine-position switch located on the front of the remote power supply.

- Multi-pattern large diaphragm tube microphone
- Perfect for a wide range of applications
- 125dB SPL handling capability
- 20Hz to 20kHz frequency response
- Includes aluminum case and elastic suspension

#STT3  
**\$599<sup>99</sup>**

**SAMSON**  
**C03**

The Samson C03 is a multi-pattern, large diaphragm studio condenser microphone that features dual 19mm ultra thin capsules that are ideal for recording vocals, acoustic instruments, or any source would benefit from its extended frequency response and fast transient response. To increase your miking options and recording techniques it features three selectable pickup patterns. The cardioid pattern is great for miking applications where tight pickup is desired, and with the omni and figure 8 patterns you can mic multiple instruments, capture room sounds, and expand your soundfield.

- Large diaphragm, multi-pattern studio condenser
- Super cardioid, omni and figure 8 pickup patterns
- 142dB handling capability
- 40Hz to 18kHz frequency response
- Swivel stand mount and carry case included

#SAC03  
**\$99<sup>00</sup>**

**CAD**  
**M-177**

The large diaphragm M177 is an excellent value when price is a consideration but sonic quality is still important. Built with CAD's attention to quality and housed in an industrial styled casing, this mic features both selectable hi-pass filtering and a 10dB attenuator for use in almost any situation.

- Large diaphragm studio condenser
- Vocals, drum overheads, acoustic instruments
- 143dB SPL handling capability
- 20Hz to 20kHz frequency response
- Includes elastic shock mount and case



#CAM177  
**\$169<sup>99</sup>**

## M-AUDIO Sputnik

#MASPUTNIK  
**\$799<sup>00</sup>**

The Sputnik is a cost-effective multi-pattern tube condenser microphone utilizing internal Class-A amplifier circuitry and vacuum tube technology to produce a warm, vintage timbre competitive with tube condensers several times its price. The Sputnik is robustly constructed with a sleek, modern appearance, and its professionally accessorized - an excellent value for home and project studio applications requiring versatility and the classic sound.

- Tube condenser microphone with Class-A amplifier circuitry
- Cardioid, omni-directional and figure-of-8 pickup patterns
- 7-pin cable, shockmount, power supply, cloth bag and flight case included
- 132dB SPL capacity
- 20Hz-20kHz frequency response



## M-AUDIO Solaris

#MASMPM  
**\$299<sup>00</sup>**

The Solaris large diaphragm condenser microphone marries vintage design with solid-state electronics into a stylish and great-sounding package. Its extremely thin evaporated gold diaphragm delivers incredible sensitivity and its multi-pattern architecture provides flexibility that makes it ideal for just about any miking situation.

- Affordable large diaphragm cardioid condenser
- Cardioid, omni, and figure-8 polar patterns
- 130dB SPL handling capability
- 20Hz to 20kHz frequency response
- Includes shock mount and aluminum case

## CAD M-9

#CAM9  
**\$299<sup>00</sup>**

CAD has combined the detail of a large diaphragm, attractive design, and the elasticity of a 12AX7 twin triode tube to create a robust tube microphone at an inviting price. It features a hi-pass filter to eliminate unwanted low frequency pickup, and the built-in attenuator reduces sensitivity, allowing it to be used almost anywhere.

- Cardioid condenser tube microphone
- High voltage 12AX7 tube design
- 155dB handling capability
- 20Hz to 20kHz frequency response
- Includes elastic shock mount and road case



## BLUE Omni Mouse

#BLOMM  
**\$1299<sup>00</sup>**

The OmniMouse is a unique microphone indeed. Based on the unique and versatile of the popular Blue Mouse, this small diaphragm omnidirectional condenser delivers a big sound. Its ability to capture direct sound as well as the ambient environment are perfect for recording sources where room tone is desired; anything from live drums and orchestral ensembles to vocal groups and horn sections.



- Omnidirectional condenser microphone
- Rotating capsule for ease of placement
- Also works well as a stereo pair
- 145dB handling capability
- 20Hz to 20kHz frequency response

## CAD GXL-3000

#CAGXL3000  
**\$169<sup>99</sup>**

It is almost unheard of to find a large diaphragm multi-pattern studio microphone at this price point. The GXL3000 is switchable between cardioid, figure of eight, and omnidirectional pick-up patterns and features both high frequency roll-off and sensitivity attenuation selectors. Now it's easier than ever to employ the advantages of a large diaphragm microphone on your own recordings.

- Multi-pattern condenser studio mic
- Cardioid, figure of eight, and omni pick-up patterns
- 135dB handling capability
- 35Hz to 20kHz frequency response
- Includes shock mount and protective pouch





**BLUE****Woodpecker**

The Woodpecker is an elegantly engineered ribbon microphone, useful for recording male and female vocals, guitars, drums, and ambient sounds. It utilizes phantom power for operation while its handmade aluminum ribbon pressure-gradient transducer delivers smooth highs, defined mids, and rounded bass. The Woodpecker is an excellently-crafted and versatile ribbon microphone, and a welcome addition to any studio.

- Low noise Class-A discrete electronics
- Bidirectional Figure 8 pick-up pattern
- Handmade precision-crafted quality parts
- Exotic wood finish
- 20Hz-20kHz frequency response
- 136dB SPL
- Includes custom shock mount and cherrywood box

#BLWPP  
**\$999<sup>00</sup>**

**ROYER LABS****R-121**

The R-121 is a sleek, modern, and versatile ribbon microphone combining warmth and clarity of sound and housed in a compact, durable metal frame. The element's figure-of-8 polar pattern exhibits increased brightness on the backside at distances of 3' or less, but is equally sensitive on either side. You can shove this mic against a Marshall stack or record an introspective vocal performance with equally effective results.

- Sensitive but durable dynamic ribbon mic with figure-of-8 polar pattern
- 135dB SPL capacity, useful as drum overheads or for miking speaker cabinets
- Ribbon element unaffected by heat or humidity
- 30Hz-15kHz frequency response
- Lifetime warranty

#ROR121  
**\$1295<sup>00</sup>**

**ROYER LABS****R-122**

The R-122 is a versatile ribbon condenser microphone with 48V phantom-powered ultra-quiet active electronics. The element exhibits a true ribbon figure-of-8 polar pattern, and the custom-wound toroidal transformer in the microphone allows for much-increased sensitivity. The phantom-powered circuitry provides optimized impedance conversion with virtually no self-noise for universal preamp compatibility.

- Durable, high-sensitivity ribbon condenser mic with figure-of-8 polar pattern
- 135dB SPL capacity, quiet 48V phantom-powered electronics
- Equal sensitivity in both front and back of mic
- Increased brightness in back of mic at shorter distances
- 30Hz-15kHz frequency response

#ROR122  
**\$1750<sup>00</sup>**

**BEYERDYNAMIC****M160**

The M160 is a dynamic dual-ribbon microphone with a hyper-cardioid pickup pattern that has found a home in many a locker as the mic of choice for recording bowed and low-output plucked-string instruments, from violas to lutes to dulcimers. Combining superior off-axis rejection with an ultra-thin and highly sensitive dual-element, the M160 offers the detailing and close-miked intimacy often associated with pricey condensers.

- Dual-element dynamic ribbon microphone with hyper-cardioid pickup pattern
- Superior detailing and off-axis rejection
- Mic of choice for stringed-instrument recording
- Glare-free chromium plating ideal for broadcast and television studio use
- 40Hz-18kHz frequency response

#BEM160  
**\$649<sup>00</sup>**

**BEYERDYNAMIC****M130**

The M130 is a dynamic golf-ball shaped dual-ribbon microphone with a figure-of-8 polar pattern designed for a variety of recording applications. Compact and robust in construction and displaying an evenness of sensitivity and frequency reproduction on either side of the capsule, this mic has been around for years.

- Dual-element dynamic ribbon microphone
- Exceptional detailing and transient response
- Excellent mic for Mid-Side stereo recording
- Versatile mic suitable for recording vocals, woodwinds and guitar cabinets
- 40Hz-18kHz frequency response

#BEM130  
**\$649<sup>00</sup>**



**ROYER LABS****SF-12**

The SF-12 is a stereo coincident ribbon microphone offering premium stereo separation and unusually high SPL capabilities. The SF-12 consists of a pair of matched ribbon mics connected one over the other and aimed 45° off-center in the classic Blumlein style. The mic is endowed with excellent phase compatibility between the two sides for artifact-free mono recording, and exhibits negligible off-axis coloration.

- True stereo microphone for Blumlein or M-S recording
- 130dB SPL capacity with no self-distortion
- Great for minimalist drum kit recording
- Free of phase anomalies, folds well to mono
- 30Hz-15kHz frequency response
- Extension cable with upper/lower "Y" XLR adapter included

#ROSF12  
**\$2695<sup>00</sup>**

**SE-ELECTRONICS****R1**

#SER1  
**\$599<sup>00</sup>**

The R1 is a professional dynamic ribbon microphone with a figure-of-8 polar pattern designed for vocal, woodwind or brass instrument, and guitar cabinet recording applications. The mic exhibits high 135dB SPL capabilities, accepting loud transients easily for distortion-free close-proximity placement.

- Dynamic ribbon microphone with figure-of-8 polar pattern
- Shockmount included
- 135dB SPL handling
- 30Hz-15kHz frequency response

**ROYER LABS****SF-24**

The SF-24 is an unusual stereo ribbon condenser microphone with active electronics supporting 48V phantom power. Basically crossed and stacked figure-of-eights, the microphone exhibits classic Blumlein and M-S stereo characteristics with a high SPL capacity free of phasing issues and mono-friendly – either side of the SF-24 may be used as a separate mono mic. The mic's unusually high sensitivity allows for use with any outboard or mixing console mic pre.

- True stereo ribbon condenser microphone
- 130dB SPL capacity with no self-distortion
- Active electronics, 48V phantom power only
- Consistent frequency response unaffected by distance
- 40Hz-15kHz frequency response

#ROSF24  
**\$4295<sup>00</sup>**

**CAD****Trion 7000**

#CAT7000  
**\$279<sup>95</sup>**



The Trion 7000 is a low-cost dual-element dynamic ribbon microphone shaped like a light bulb. The microphone's figure-of-8 polar pattern offers equal sensitivity and frequency response on both sides of the capsule, which is housed in exceptionally durable metal housing. The Trion 7000 is an excellent value for home and project studio recording applications.

- Dynamic dual-element ribbon microphone with figure-of-8 polar pattern
- Shockmount and aluminum case included
- Versatile alternative to standard dynamic instrument mics
- 20Hz-10kHz frequency response

**SAMSON****VR88 Velocity Ribbon Microphone**

Samson's VR88 is a cost-effective ribbon condenser microphone featuring a sensitive, ultra-thin corrugated aluminum ribbon element residing in a shockmounted capsule. The microphone's figure-of-8 polar pattern provides even pickup response on both sides of the capsule, and a gracious acceptance of loud, close-proximity transient signals that make it ideal for guitar cabinet and brass instrument recording.

- 48V phantom-powered dual-element ribbon condenser microphone
- 138dB SPL, excellent loud transient response
- Shockmount, swivel stand and aluminum case included
- 30Hz-16kHz frequency response

#SAVR88  
**\$499<sup>00</sup>**



## SCHOEPS CMC641SET

A favorite in film and music production, the Schoeps Colette series is known for its pristine sound quality and flexibility. Featuring transformerless electronics, the CMC6 preamplifier can utilize a number of different capsules for a variety of demanding production situations. The MK41 super-cardioid capsule has a directional yet very natural-sounding response and is used in a variety of applications from live television to interior film production shoots.

#SCCMC641S  
**\$1939<sup>00</sup>**



- Scalable design with 20 optional capsules
- Superior natural sound
- Low noise floor
- Transformerless electronics
- 40Hz–20kHz frequency response

**CUT1** low-cut filter (60Hz at 24dB octave) #SCCUT1..... **\$675.00**  
**B5DG** Hollow foam windscreen #SCB5DG..... **\$62.00**

## SENNHEISER MKH-30

The MKH-30 from Sennheiser is a unique recording microphone. Its figure of 8 pick-up pattern is particularly effective at the rejection of lateral sounds and the suppression of sounds from adjacent sources. Boasting a wide and open-sounding frequency response, it's an excellent tool for capturing a soloist or small instrumental groups. It comes equipped with a roll-off filter and switchable attenuation.



- Wide frequency response
- Very low self noise
- Roll-off filter
- Figure 8 pattern
- 40Hz–20kHz frequency response

#SEMKH30  
**\$1499<sup>50</sup>**

## SENNHEISER MKH-50

Sennheiser's MKH-50 is a super-cardioid condenser microphone of exceptional quality. The MKH series delivers ultra low inherent self noise, transformerless circuitry, and stunning audio. The MKH-50 really shines in the area of side rejection, zeroing in on specific sounds in close miking situations. Whether you're on stage, on set, or in the studio, the MKH-50 will stay directed on a sound source without sacrificing frequency range.

#SEMKH50P48  
**\$1395<sup>95</sup>**



- High rejection of lateral sounds
- Roll-off filter switch
- 134dB SLP
- Lightweight black anodized metal
- 40Hz–20kHz frequency response

## DPA 4006-TL

The DPA 4006-TL is an extremely linear small-diaphragm omnidirectional microphone that combines a new highly sensitive transformerless design with the flexible option of adding up to seven different acoustic pattern modifications. Known for its truly neutral and precise sound quality, the 4006 is most often found in critical musical, acoustic measurement, and broadcast applications.

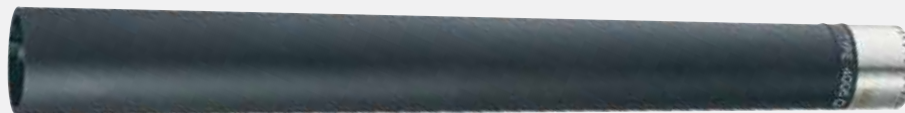

#DP4006TL  
**\$1769<sup>95</sup>**

- Applications include: stereo pairing for symphonic hall recordings, acoustic piano and guitar, percussion, and vocals
- Optional acoustic filters for versatile pattern modification
- Transformerless design with extremely wide response and sensitivity
- 143dB SPL • 10Hz–20kHz frequency response

## NEUMANN KM184

Ideal for solo instruments, ensemble, and spot miking, the compact KM184 is a small diaphragm cardioid condenser microphone that offers premium Neumann sound that's both "open" and "musical." Two other polar patterns are available in the "Series 180", the KM183 omnidirectional condenser, and the KM185 hypercardioid condenser.

#NEKM184MT  
**\$849<sup>99</sup>**



- Sold individually or in matched stereo pairs
- Available in non-reflective black or nickel finish
- 138dB SPL
- 20Hz–20kHz frequency response
- Wooden jewel box, windshield, stand and cable mount (included)

**KM183** small diaphragm with omnidirectional pattern #NEKM183MT..... **\$899.00**  
**KM185** small diaphragm with hypercardioid pattern #NEKM185MT..... **\$899.00**



**AKG**  
**C451B**

#AKC415B  
**\$569<sup>00</sup>**

A re-issue of the popular C451, the C451B delivers the same well-defined, articulate sonic characteristics of its predecessor, still making it great for use on acoustic guitars, drums, percussion or overhead miking. The all-metal body provides excellent protection from RF interference, and the microphone is rugged enough for even the most demanding applications.



- Selectable 10dB, 20dB pad
- 20Hz–20kHz frequency response
- Excellent transient response
- 155dB SPL
- Selectable low-frequency roll-off switch

**C451 B/ST** matched stereo pair with complete accessories in a carrying case  
#AKC451BST..... **\$1199.00**

**AUDIO-TECHNICA**  
**AT4053A**

The modular AT4053A is a professional small-diaphragm hypercardioid condenser microphone designed with a fast, transparent response that handles high sound pressure levels with superior clarity and detail. It's easily adapted to cardioid or omni patterns utilizing the optional omni or cardioid capsules, making the versatile AT4053A a great choice for reproducing even the most troublesome instruments and sound effects accurately.



#AUAT4053A  
**\$499<sup>00</sup>**

- Modular design for cardioid, omni, and hypercardioid miking needs
- Durable, rugged brass chassis
- Built-in 80Hz filter
- 48V phantom powered
- 146dB SPL
- 20Hz–20kHz frequency response

**AUDIO-TECHNICA**  
**AT4051A**

The Audio-Technica AT4051a is an exceptional small diaphragm cardioid condenser microphone. Its low self noise design is achieved with a direct-coupled balanced output, unlike conventional transformer-coupled microphones. The result is a versatile tool for production in critical music and broadcast studios. Optional pattern capsules are available for flexibility.

#AUAT4051A  
**\$499<sup>00</sup>**

- Fast transient response
- 80Hz hi-pass filter switch
- Phantom powered
- Interchangeable capsules
- 20Hz–20kHz frequency response



**AT4053A-EL** small diaphragm hypercardioid capsule #AUAT4053AEL..... **\$195.00**

**SHURE**  
**KSM141SL**

The Shure KSM141SL is a high-output, low-noise small diaphragm condenser microphone with an extremely fast transient response and smooth harmonic control. Its discrete Class-A circuitry delivers superior transparency and accuracy while the dual polar pattern capsule provides engineers the flexibility of both omni and cardioid pick-up patterns. Ideal for acoustic instrument studio recordings, the KSM141SL features control that's equally well suited for live ensemble and ambience recordings.



#SHKSM141SL  
**\$399<sup>00</sup>**

- Class-A, transformerless preamplifier
- Dual polar patterns (cardioid and omni)
- 145dB SPL
- Three-position pad (0dB, 15dB, 25dB) and three-position switchable low-frequency filter
- 20Hz–20kHz frequency response

**SHURE**  
**SM81 LC**

#SHSM81LC  
**\$349<sup>00</sup>**

The Shure SM81 LC is a high-quality small diaphragm cardioid condenser microphone designed for studio recording, broadcasting, and sound reinforcement. The ruggedly constructed SM81 LC can also serve as a field recording mic with consistent performance over a wide range of temperature and humidity conditions. Its flat, neutral frequency response makes it particularly well-suited for use on acoustic guitar, piano, cymbals, and choirs.



- Requires 48V phantom power
- Selectable low-frequency rolloff
- 10dB lockable attenuator switch
- Rugged steel construction for durability
- 131dB SPL
- 20Hz–20kHz frequency response
- Carrying case, windscreen, swivel adapter and attenuator-switch lock (included)

**STUDIO PROJECTS****C4**#STC4  
**\$399<sup>99</sup>**

Studio Projects is known for producing affordable yet stellar-sounding microphones, and the C4 kit is no exception. Sold in a pair with cardioid and omni capsules, it's well equipped to handle myriad production tasks, from live music and studio production, to location sound and ambient recording. Each ruggedly-built microphone features a 10 dB pad and a high-pass filter.

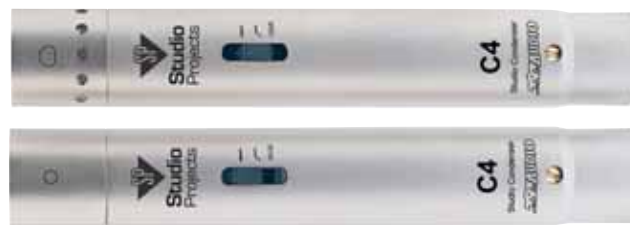

- Case, shock mount and wind-screen included
- Interchangeable omni and cardioid capsules
- Gold-plated XLR connection
- Phantom powered
- 40Hz–20kHz frequency response

**AUDIO-TECHNICA****AT4041**#AUA4041  
**\$279<sup>00</sup>**

The AT4041 is a small diaphragm condenser microphone that, as an instrument mic, can be used on virtually any source requiring a cardioid response. Its accuracy, detail, and highly-sensitive capsule make it an obvious choice for solo acoustic instrument recordings, sound effects gathering, and choir and small acoustic ensembles.



- Ideal for guitar, piano, and overhead miking
- High level handling ideal for percussion and brass
- Smooth, extended response with slight high-end emphasis
- Transformerless design for quick response and virtually no low frequency distortion
- Rugged brass housing with switchable high-pass filter
- 48V phantom powered
- 145dB SPL
- 20Hz–20kHz frequency response

**CROWN****CM-700**#CRCN700  
**\$284<sup>95</sup>**

A strong contender as an engineer's everyday-use microphone, the Crown CM-700 is an extremely flexible small diaphragm cardioid condenser microphone capable of particularly close miking of high volume, powerful sound sources. The aggressive yet accurate and open sound of the mic makes it an ideal choice for use on percussion, rhythm guitar, bass, and even vocals.



- Smooth, round response
- Slim, compact design
- Humbucking transformer for lower noise
- Low cut and bass roll-off switch
- 151dB SPL
- 30Hz–20kHz frequency response

**RODE****NT3**#RONT3  
**\$249<sup>00</sup>**

The RODE NT3 is an affordable hypercardioid condenser microphone ideal for location, studio, and live use.

Its transformerless output and quality construction delivers open, pristine sound. The microphone has the ability to be powered by a single 9V battery, making it a great solution for field recording.



- 48V phantom powered with optional 9V battery operation
- Internal capsule shock mounting
- Battery status indicator
- 140dB SPL
- 20Hz–20kHz frequency response
- Zipper pouch, windscreens and stand mount (included)

**AKG****C1000S**#AKC1000S  
**\$219<sup>00</sup>**

Particularly well suited for mobile recordings, the C1000S is capable of 9V battery or phantom powering. It features a small diaphragm condenser element with a cardioid pattern that is quickly changed using the provided converter, reducing noise and improving source signal isolation. The versatile C1000S provides a slight presence boost improving clarity and definition, especially on vocal ensembles, ambient location, and studio recordings.



- Versatile-use microphone capable of both studio and mobile recording applications
- Battery status LED
- PB 1000 Presence Boost Adapter included for high-end enhancement
- PPC 1000 converter allows easy switch to hypercardioid pattern
- 137dB SPL
- 50Hz–20kHz frequency response

**MXL**  
**603s**

#MXMXL603P  
**\$199<sup>00</sup>**

The MXL 603s is an affordable matched pair of condenser microphones with some impressive features. Its gold-sputtered diaphragm and transformerless design deliver a clean and open frequency response. Inside it's wired with world-class Mogami cable and housed in a satin silver-finished body. With a wide and forgiving cardioid pick-up pattern, it's an effective tool for capturing a large range of sounds and instruments.



- Gold diaphragm
- 137dB maximum SPL
- Case & shock mounts included
- Silver metal finish
- 30Hz–20kHz frequency response

**SHURE**  
**KSM109/SL**

#SHKSM109SL  
**\$179<sup>00</sup>**

The KSM109 is a small diaphragm cardioid instrument microphone designed for critical recording applications. It combines an extended frequency response for natural sound reproduction with a smooth high end and a tight, controlled low end. This versatile microphone features an ultra-thin diaphragm, transformerless Class-A pre-amplifier circuitry and a 15dB pad for high SPL sound sources.



- Tight cardioid polar pattern
- Transformerless Class-A preamplifier circuitry
- Smooth high end & a tight, controlled low end
- Low self noise
- 20Hz–20kHz frequency response
- Switchable 15dB pad
- Includes: lip, windscreens & carrying pouch

**AUDIO-TECHNICA**  
**AT3031**

#AUAT3031  
**\$169<sup>00</sup>**

The Audio-Technica AT3031 is an affordable small diaphragm cardioid microphone suitable for studio recording purposes. Its compact size opens up possibilities for mic placement, and its high SPL handling allows you to use it on a variety of sources. A low-mass element provides excellent transient response whether you're capturing a gentle voice or a loud crash cymbal.



- 148dB SPL rating
- 80Hz hi-pass filter
- 10dB pad
- Low self noise
- 30Hz–20kHz frequency response

**AT3032** *small diaphragm with omnidirectional pattern*  
#AUAT3032..... **\$169.00**

**SE-ELECTRONICS**  
**SE1a**

#SESE1A  
**\$149<sup>95</sup>**

The SE1a from SE-Electronics is a solidly-designed small diaphragm condenser microphone.

A standout performer for capturing the sound of an acoustic guitar, the SE1a's end firing cardioid pick-up pattern is useful in many recording situations. With a 137 dB SPL rating, it's a great tool for recording loud percussion. Its wide response makes it an ample tool for capturing a piano's demanding frequency spectrum.



- Cardioid polar pattern
- Phantom powered
- Rugged build quality
- Low self noise
- 30Hz–20kHz frequency response

**SAMSON**  
**C02**

#SAC02  
**\$119<sup>00</sup>**

The Samson C02 is an inexpensive pair of pencil style small diaphragm microphones. Useful in the studio and live sound situations, the C02's cardioid pattern is effective at rejecting sounds to the rear and minimizing feedback. Placed in close proximity to the sound source, the C02 will boost bass frequencies. It also features built-in windscreen and an additional external windscreen for outdoor use.



- Cardioid pick-up pattern
- Case & shock-mounted clips included
- Stereo pair
- 134dB maximum SPL
- 40Hz–20kHz frequency response



**AUDIO-TECHNICA****AT3032**#AUAT3032  
**\$169<sup>00</sup>**

The low-profile AT3032 omnidirectional mic is outstanding for piano, acoustic guitar, and other acoustic instruments without the limitations brought on by the proximity effect. Known for its flat, extended frequency response and wide dynamic range, it handles high SPL's with ease and features low self noise for use in more demanding situations.



- Omnidirectional small diaphragm mic
- Lo-cut switch and 10dB pad
- 158dB SPL handling capability
- 30Hz to 20kHz frequency response
- Includes windscreen and protective pouch

**AKG****Perception 150**#AKP150  
**\$129<sup>95</sup>**

AKG has crashed the price barrier with this truly affordable small diaphragm cardioid condenser microphone. Its attractive price makes it easy to consider purchasing a pair for use as choir or drum overheads, for small ensemble recording, and for both studio and live sound applications. This mic represents an outstanding value for schools, houses of worship and project studios.



- Highly affordable small diaphragm cardioid condenser
- Switchable pre-attenuation pad
- 145dB SPL handling capability
- 20Hz to 20kHz frequency response
- Includes stand adapter and carry case

**SE-ELECTRONICS****SE2A**#SESE2A  
**\$349<sup>95</sup>**

With its fantastic value for the dollar, it is hard not to consider using more than one SE2A for multiple recording tasks. This small diaphragm condenser comes with three different interchangeable capsules, allowing you to tailor its pick-up pattern for the application at hand.



- Small diaphragm condenser mic
- Cardioid, omni, and hypercardioid capsules
- 137dB SPL handling capability
- 30Hz to 20kHz frequency response
- Includes shock mount and flight case

**AUDIX****TR-40-MP**#AUR40MP  
**\$449<sup>00</sup>**

The TR40 is the first in a series of test and recording microphones specially designed by Audix. It delivers extremely linear frequency response characteristics, and its omnidirectional capsule is ideal for certain studio and live recording applications, such as piano, musical ensembles, and choirs.



- Matched pair of omnidirectional condensers
- 1/4" diameter pre-polarized capsule
- 128dB SPL handling capability
- 20Hz to 19kHz frequency response
- Includes protective pouch and storage box

**AUDIO-TECHNICA****Pro 37**#AUPRO37  
**\$139<sup>95</sup>**

With a low mass element for superb transient response and an extremely low-profile design for optimal mic placement, the Pro 37 excels in high-SPL applications. It is ideal for acoustic instruments and overhead applications, and its cardioid polar pattern reduces pickup of sounds from the sides and rear, improving isolation.



- Low-profile small diaphragm condenser
- Studio and sound reinforcement applications
- 141dB SPL handling capability
- 30Hz to 15kHz frequency response
- Includes windscreen and protective pouch

**SENNHEISER**  
**MKH 8000 Series**

The all-new 8000 Series microphones from Sennheiser represent a collection of very compact and very versatile recording tools designed for use in a variety of situations. The mic elements and XLR modules are housed separately for the ultimate in placement options.

**MKH-8020 Set**  
omnidirectional / 10Hz to 60kHz freq. response / 138dB SPL  
#SEMKH8020 ..... **\$1200.00**

**MKH-8040 Set**  
cardioid / 30Hz to 50kHz freq. response / 142dB SPL  
#SEMKH8040 ..... **\$1200.00**

**MKH-8050 Set**  
super-cardioid / 30Hz to 50kHz freq. response / 142dB SPL  
#SEMKH8050 ..... **\$1200.00**

All models include windscreen, clip, and case



**NEUMAN**  
**KM 184D**

In our current world of digital workstation and hard disk recorders, the ability to digitally connect your microphone directly to your system would seem like a logical step. Now there is a line of small diaphragm cardioid digital microphones that combines the famed Neuman sound with the added benefit of S/PDIF or AES/EBU output to keep your signal chain in the digital domain from beginning to end.

**\$1499<sup>00</sup>**



**KM 184 D 44SPD** 24-bit / 44.1kHz with S/PDIF output #NEKM184D44S  
**KM 184 D 48SPD** 24-bit / 48 kHz with S/PDIF output #NEKM184D48S  
**KM 184 D 44AES** 24-bit / 44.1kHz with AES/EBU output #NEKM184D44A  
**KM 184 D 48AES** 24-bit / 48kHz with AES/EBU output #NEKM184D48A

Includes storage box and winscreen

**EARTHWORKS**  
**P30**

The Periscope High Definition Series from Earthworks features a 4-inch flexible neck and small microphone head that can be positioned or placed where other microphones cannot. The omnidirectional character of the P30 is great for overhead recording as well as acoustic guitar, piano, and amplified instruments.



#EAP30B  
**\$879<sup>00</sup>**

- Omnidirectional, high-definition microphone
- Flexible neck for easy positioning
- 142dB SPL handling capability
- 9Hz to 30kHz frequency response
- Includes protective case

**SENNHEISER**  
**ME62**

The ME62 is an omni-directional condenser microphone useful for capturing musical performances, or as an interview and discussion-group miking solution involving several speakers. It's also a good choice for use as an ambient mic for live or recording applications, with full-range frequency reproduction and nice detailing.

#SEME62  
**\$149<sup>95</sup>**



- Omni-directional condenser microphone capsule
- Minimal self-noise
- Anodized scratch-resistant finish
- 130dB SPL
- 20Hz-20kHz frequency response

**K6** AA battery/phantom powering module for ME62 #MEK6 ..... **\$209.95**

**SENNHEISER**  
**MKH-20**

The MKH 20 is ideal for use as an overhead mic, for pickup of solo instruments, and among other applications, as a main microphone for orchestral recordings. Its exceptionally wide frequency response and lack of any proximity effect allow this microphone to be easily placed to deliver rich detail without an over-accentuated low end.

#SEMKH20  
**\$1395<sup>95</sup>**



- High-performance omnidirectional recording mic
- Transformerless output for transparent sound
- 134dB SPL handling capability
- 12Hz to 20kHz frequency response
- Includes shock mount and windshield

### SAMSON G-Track

This large diaphragm studio condenser not only does a great job of capturing your vocal performances, but also provides a built-in USB audio interface and mixer as well. Now you can record your voice along with guitar, bass, or keyboards while monitoring through the onboard headphone output. This gives singer/songwriters an easy-to-use, ultra-portable solution for getting their work done with a minimum of gear.



#SAGM1U  
**\$129<sup>99</sup>**

- Large diaphragm USB condenser microphone
- Mic and Instrument/Line gain control with clip LED
- Stereo input jacks for line/instruments
- No latency headphone monitoring
- USB bus-powered and compliant

### BLUE Snowflake



The Snowflake is an ultra-compact yet high-quality plug-and-play USB condenser microphone. It's cleverly designed to fold into itself, USB cable and all, for storage and travel, and to unfold into a desktop stand – or to clip onto the monitor of laptop. Musicians, podcasters, and journalists will appreciate its ease of use and handsome design. No drivers are needed, you just plug in to any Mac or PC and record great sounding audio.

- USB cable included
- Folds into a case, folds out into a stand or clip
- Conforms to BLUE's high standards for sound quality
- Compact enough to keep in laptop bag, or in your pocket
- Compatible with Mac and PC, no software drivers needed
- 3 year limited warranty

#BLSF  
**\$59<sup>00</sup>**

The Snowflake is an ultra-compact yet high-quality plug-and-play USB condenser microphone. It's cleverly designed

to fold into itself, USB cable and all, for storage and travel, and to unfold into a desktop stand – or to clip onto the monitor of laptop.

### BLUE SnowBall USB with accessory kit

The Snowball USB is a dual-capsule microphone designed to interface with laptop and desktop computers via USB. This bus-powered, plug-n'-play mic features a three-pattern switch (cardioid, cardioid with 10dB pad and omni) and is ideal for music production, DV-looping /dialog recording, podcasting, and video post-production applications.

- USB bus-powered condenser
- Seamless integration with audio software
- Unique dual-capsule design
- 3-pattern switch (cardioid, cardioid w/ 10dB pad & omni)
- 10 dB pad switch
- Includes tripod stand & USB cable
- Frequency response: 40Hz -18kHz
- Windows XP and Mac OS X compatible



#BLSBAPB  
**\$99<sup>00</sup>**

### RODE Podcaster

The Rode Podcaster is a result of years of experience in the business of building well-designed and great-sounding microphones. This broadcast-quality, end-address USB microphone features a tailored-for-voice frequency response that delivers rich, full results. A status LED lets you know that your mic is online, and there is an onboard headphone output jack with its own volume control for the ultimate in convenience.

- High-quality dynamic USB broadcast mic
- Internally shock-mounted 28mm neodymium capsule
- Tight cardioid pattern for superior off-axis rejection
- Ideal for pro-quality studio and field applications
- Power supplied from USB port



#ROPODCASTER  
**\$229<sup>00</sup>**

### SAMSON C01UCW

The C01U is a cardioid condenser microphone with a built-in USB port ideal for musicians, podcasters, journalists, students, and business people adding audio files to websites and multimedia presentations. It features a 19mm internal shock mounted diaphragm and a heavy-gauge mesh grille, and works seamlessly with both Mac & PC computers. This versatile mic supports sampling rates up to 16-bit/48 kHz.

- Cardioid condenser with built-in USB port
- 19mm internal shock-mounted diaphragm
- Heavy-gauge mesh grille
- Smooth, flat response
- USB cable included
- Compatible with Mac & PC
- Frequency response: 40Hz -18kHz

#SAC01UCW  
**\$89<sup>00</sup>**





## SE-ELECTRONICS USB2200A

#SEUSB2200A  
**\$399<sup>00</sup>**

SE is offering a truly professional USB recording alternative with this cardioid condenser microphone. It features a full 1" hand-crafted, gold-plated diaphragm and offers zero-latency monitoring with its own built-in headphone output and "Mix vs. Mic" level control. Unlike most other USB microphones, the USB2200A features XLR output as well to provide single or dual output operation for true versatility. As an extra precaution, voltage has been conditioned to address the usual noise problems associated with using power via USB.

- Professional-grade cardioid condenser USB mic
- Simultaneous XLR and USB output
- 100Hz roll off and 10dB pad switches
- Large diaphragm with 20Hz to 20kHz frequency response
- Includes mounting cradle and padded case



## SE-ELECTRONICS USB1000A

#SEUSB1000A  
**\$199<sup>00</sup>**

The USB1000A is a great choice for computer recording with its built-in USB port for direct connection and a 1/2" diaphragm for a full rich sound. There is a dedicated PC/Apple switch on its face and entering USB voltage is conditioned before being applied to the mic for a clean signal. Solid build quality and compact size make for excellent durability and easy placement.

- Cardioid condenser USB microphone
- Voltage conditioning maintains clean signal
- Perfect for Podcasting and voice-over work
- 20Hz to 20kHz frequency response
- Integrated mounting cradle and padded case

## MXL USB.008

#MXMXLUSB008  
**\$169<sup>95</sup>**

The MXL USB.008 makes a fantastic choice for podcasting, broadcasting, narration, and multimedia with its large 32mm condenser capsule and cardioid pick-up pattern. With USB connection to your computer there is no need for any specialized studio gear. All you have to do is set your preferences and enjoy instant professional-quality recordings in your favorite software. The mic even has real analog volume adjustment to ensure correct pre-digital levels going into your computer.

- USB-equipped large diaphragm mic
- Condenser element with 32mm capsule
- Allows for true portability and versatility
- 20Hz to 20kHz frequency response
- Mac and PC compatible



## MXL USB.006

#MXMXLUSB006  
**\$129<sup>95</sup>**

The USB.006 was designed to deliver the big rich sound of a studio condenser in a package that connects directly to your computer for maximum ease of use. As a plug-and-play device for both Windows and Macintosh, it requires no special drivers whatsoever, and so makes a perfect portable solution for podcasting and location recording. With selectable attenuation it is easy to adapt this microphone to capture virtually any sound source without the need of external pre-amps or multiple cables.

- Large diaphragm USB condenser microphone
- 0dB, -5dB and, -10dB attenuation switch
- Cardioid pick-up pattern and integrated pop filter
- 20Hz to 20kHz frequency response
- USB 1.1 and 2.0 compatible



## MXL USB.007

#MXMXLUSB007  
**\$189<sup>95</sup>**

The USB.007 large diaphragm condenser microphone is just as simple to use as MXL's other USB models but, allows you to record in stereo while still connecting to your computer with only a single USB cable. This opens up new possibilities for capturing live performances, podcasts, concerts, outdoor environments, and sound effects in stereo for film work. Now you can set up shop anywhere in the world and document your work in full stereo for remarkable results with minimum hardware.

- Dual gold diaphragm capsules in an XY pattern
- Stereo recording over a single USB cable
- Low noise electronics
- Enhanced digital conversion
- Add a new dimension to your podcasts



**TRUE SYSTEMS****Precision 8**#TRP8  
**\$2599<sup>00</sup>**

Featuring high headroom and very low-noise operation, the Precision 8 is an eight-channel solid state microphone pre-amp capable of producing realistic, transparent, live, and direct tracking performances. Designed with a straightforward front panel and flexible hard-disk and console connectivity, the accurate and detailed Precision 8 provides engineers a complete, effective single-space input system for both on-location and studio recordings.



- (8) highly-transparent and detailed solid state mic preamps
- (2) selectable high-impedance instrument DI's
- Built-in M-S (Mid-Side) decoding for creative spatial image control
- 5-segment level indicators with peak hold and selectable peak reference
- DB25 and TRS outputs for flexible interconnection to MDM's, HDR's, DAW's or consoles
- Smooth, continuous gain controls



- Classic sound of the renowned 610 Modular Console
- Join/Split switch allows entirely independent operation of each unit
- HF and LF Shelving EQ
- Mic, Balanced line, and Hi-Z Inputs
- Variable input gain and output levels
- Internal switching power supply

**UNIVERSAL AUDIO****6176**

6176 is a tube-channel strip comprised of the classic 610 Microphone Preamp and legendary 1176 Compressor. With its tremendously flexible tone, function, and ultra-quiet operation, the 6176 is the perfect analog front end for digital audio recording.

#UN6176  
**\$2399<sup>00</sup>****FOCUSRITE****Liquid Channel**#FOLC  
**\$2499<sup>99</sup>**

The Focusrite Liquid Channel is a high-end single-channel strip capable of producing remarkable replicas of up to 40 different analog preamps and/or compressors with a sampling rate up to 192k. This innovative technology combined with its impressive user interface and subtle tone-shaping EQ, provides professional studio engineers a valuable tool with the flexibility to create unique tonal variations that may have never previously existed.



- (40) Preamp and Compressor replicas
- Ultra-wide gain and dynamic range
- Front panel includes: (14) rotary encoders, (26) pushbuttons, and 235 LED's
- 3-band EQ with high/low sweepable shelves and variable-Q mid
- Extremely low latency
- Download additional replicas using LiquidControl software for Mac/PC
- 24-bit/192kHz



- Balanced XLR I/O and 1/4" front panel instrument input
- Large VU meter for monitoring output level and compressor gain reduction
- EQ section switchable between Pre/Post compressor
- Two VT-737SP's can be linked for stereo tracking
- Internal switching power supply

**AVALON****VT-737SP**#AVVT737SP  
**\$2250<sup>00</sup>**

VT-737SP is a single-channel, vacuum tube Class-A processor that combines a tube Mic preamp, Instrument DI, Opto-Compressor, and a 4-band Parametric EQ. The high-performance VT-737SP adds incredible warmth, depth, and character to digital recordings, providing the perfect analog channel strip for Digital Workstation and Broadcast Studios.

**TUBE-TECH****MEC-1A**

MEC-1A is a premium recording channel that combines all the classic tube-based designs of the MP 1A Mic Preamp, EQ 1A Equalizer, and CL 1B Compressor in a powerful two-unit package. This three-in-one solution is an ideal analog signal path for today's digital studio, handcrafted to deliver vintage warmth with unrivaled accuracy and depth.

#TUMEC1A  
**\$4400<sup>00</sup>**

- Mic preamp features: phase reverse, low-cut roll-off filter, 20dB pad
- 1/4" unbalanced Hi-impedance input
- 3-band EQ with Hi/Low shelving at 6 frequencies and Band filter at 12 frequencies (Bell type)



- Separate In/Out switch for both EQ and Compressor
- Clickless swap relay between EQ and Compressor
- Internal switching power supply

### BLUE ROBBIE

#BLRMP  
**\$999<sup>00</sup>**

Elegance and simplicity are the driving forces behind Blue's design philosophy, and Robbie is no exception. This Class-A discrete tube microphone and instrument pre-amp features the same technical build quality and commitment to excellence for which Blue is known.

- Excellent detail with extremely low noise and ultra-high gain
- Warm, robust, tube gain stage with solid-state output
- Discrete, balanced components from input to output
- Hi-Z 1/4" instrument line input
- 20dB pad
- 10Hz-100kHz frequency response



### UNIVERSAL AUDIO LA-610

#UNLA610  
**\$1499<sup>00</sup>**

Capable of superior results tracking all types of audio, the Universal LA-610 is an ideal analog front-end for today's modern Digital Audio Workstations. The simple-to-use, but sophisticated sounding LA-610 combines the award winning "all tube" warmth and character of legendary console modules with the superior musical control and signature sound of the classic T4 Compressor, into a single, sonically versatile channel strip.

- Transparent or robust, the tube preamp shows tremendous range of sonic shading and control
- Two bands of shelving EQ with switchable frequencies
- Authentic Teletronix LA-2A-style T4 opto-compressor/limiter
- Low-noise, Hi-gain circuitry
- Hi-Z (direct) input

### FOCUSRITE ISA 220 Session Pack

#FOISA220SP  
**\$1499<sup>99</sup>**

ISA 220 Session Pack is a single-channel analog processor that includes a precision Mic preamp, flexible EQ section, Compression/Limiting, and a De-esser in one high-quality channel strip. With Focusrite's renowned sound quality and its flexible design, the ISA 220 Session Pack provides audio professionals in both music and post-production with a complete channel-strip solution at a competitive price.



- XLR I/O, and 1/4" Hi-Z instrument input
- 4-band EQ with Hi/Low-pass filters
- New "Blend" feature for adding dynamics into compressor signal path
- Precision VU metering of input or compression gain reduction
- Optional 24-bit/96kHz A/D card with AES/EBU, S/PDIF, and ADAT lightpipe



### AVALON M5

#AVM5  
**\$1575<sup>00</sup>**

M5 is a pure Class-A microphone preamp designed to optimize absolute signal integrity and musical detail. Ideal for Vocals and Acoustic instruments, the M5's 100% discrete circuit design provides demanding audio professionals with the highest standard in performance and sonic excellence.

- Balanced XLR I/O, and 1/4" Hi-Z input
- Active DI input for Bass, Guitar, and Keyboards
- Large Illuminated VU meter
- Minimum Audio Signal path
- External AC Power supply, 100V-240V selectable
- Rugged half-rack space chassis with optional rack mount kits

### AVALON U5

#AVU5  
**\$585<sup>00</sup>**

The U5 is a premium-quality Class-A instrument DI and preamplifier. Designed to optimize signal integrity and musical performance, the U5 is ideal for low-level instruments including bass (especially) and electric guitar, acoustic instruments, keyboards, and synthesizers. For the audio professional, its non-compromised build and feature set provides superior sensitivity, clarity, and subtle warm tonal characteristics of a truly worthwhile investment.

- Pure Class-A 100% discrete electronics
- Variable "boost" for matching levels and gain control (up to 30dB)
- High-cut filter
- Dual balanced XLR mic and line level outputs
- 400-watt speaker input for direct recording
- 1/4" instrument input





**UNIVERSAL AUDIO****DCS Remote Preamp**

The Universal Audio DCS Remote Preamp is a unique 2-channel microphone preamp designed for smooth DAW co-integration. Combining two transparent, trans-impedance mic pre's with a remarkably full-featured, 100% digital remote control path, the unit allows for convenient extended location next to the producer or engineer in larger facilities.

#UNDCSRP  
**\$1199<sup>00</sup>**

- Transparent, console-grade remote mic preamps
- Flexible dual-mono, stereo or MS-Stereo recording
- 4Hz-150kHz, +0/-3dB frequency response
- Intuitive remote control work surface with backlit VU metering
- Remote connects via Cat-5 cable (up to 300')
- Remote includes: headphone amp, monitor-only reverb and EQ

**UNIVERSAL AUDIO****4110**#UN4110  
**\$3499<sup>00</sup>**

The 4110 is a discrete 4-channel, 4RU microphone preamp, combining vintage warmth and classic durability with the hi-fi transparency and maxed-out headroom required for modern digital recording. Each channel of the 4110 provides must-have pro features such as dedicated Gain and Level controls, input and output metering, dual-input impedance selection, and custom input stage transformers.

- 3-mode "Shape" switch tailors character of input signal
- XLR mic/line and Hi-Z inputs
- 10Hz-60kHz frequency response
- 74dB Gain, +30dBu output level
- Dual-stage level controls
- Input and output metering
- Ultra-fast transient response
- High headroom

**AVALON****AD2022**#AVAD2022  
**\$2970<sup>00</sup>**

The AD2022 is a discrete 2-channel microphone preamplifier, featuring a Pure Class-A design with rich, transparent sonic detailing and a rugged construction worthy of life-long professional use. The dual-mono AD2022 offers selectable mic input impedance-matching, high headroom and incredibly low noise, a -20dB input pad, and dual Hi-Z instrument inputs. The ultra-fast transient response of the unit allows for a very wide range of recording applications.



- 1Hz-120kHz -3dB frequency response
- +36dB maximum mic level
- +20dB to +64dB Gain Range on input
- XLR microphone and Hi-Z inputs
- Variable high-pass filter eliminates LF rumble
- Illuminated VU meters, bi-color peak LED's
- Input phase reverse switches
- Sealed silver relays for all signal routing

**PRESONUS****ADL600**#PRADL600  
**\$1995<sup>95</sup>**

The ADL 600 is a high-voltage, two-channel microphone preamp designed by world-renown analog tube circuit designer Anthony DeMaria to deliver stunning sonic performance and stand up to years of professional studio use. It utilizes three high voltage tubes per channel for maximum headroom and a sound that is big, warm, smooth, and clear. The sonic character of this box will lend a unique quality to your vocal performances and give instruments a new sense of depth and liveliness.

- Two channel Class A microphone preamp
- (2) XLR mic, (2) XLR line, and (2) 1/4" instrument inputs
- Switched gain and variable fine trim controls
- Analog VU and fast-acting LED metering
- Selectable microphone input impedance

**SOLID STATE LOGIC****XLogic Alpha Channel**#SOAC  
**\$1695<sup>95</sup>**

The XLogic Alpha Channel is a single-channel microphone preamplifier equipped with a limiter, 3-band parametric EQ, and a 24-bit A/D converter featuring auto-sensing, self-adjusting sample rate conversion. Housed in a rugged 1RU metal chassis, with SSL's legendary sonic power and ultra-quiet operation, the XLogic Alpha Channel represents a surprisingly affordable way to obtain upper-echelon sound quality for the project or commercial studio owner.



- Elite-quality mic preamp and signal processor
- XLR Combo jack, 1/4" TRS and RCA analog connectivity
- Coaxial SPDIF digital connectors
- Variable Harmonic Drive
- 24-bit A/D converter with self-adjusting SRC
- Powerful 3-band SSL EQ with MF Q-control, dual LF curves
- Intelligent program-dependent limiter

**GRACE DESIGN**  
**m802**

#GRM802  
**\$4685<sup>95</sup>**

The M802 is a remote-controlled 2RU 8-channel program-mable microphone preamplifier designed for high-end DAW recording. It has a richly-detailed sound with a huge presence and crystalline purity. The M802 features a fully-balanced, transformerless design, fast trans-impedance amplifier architecture, with precise, illuminated LCD digital metering, a dedicated ribbon mic operating mode, and direct control from compatible DAW control surfaces and MIDI devices.

- Dual XLR and D-Sub high-current outputs
- 15Hz-300kHz frequency response
- -7dB to +63dB gain range
- Remote control up to 64 channels
- Programmable Phase, Gain, and Phantom Power
- Digital metering with peak hold and reset
- Channel Group Mode for stereo pairs and subgroups



**GRACE DESIGN**  
**Model 201**

#GRM201  
**\$2125<sup>00</sup>**

The M201 is an elite 2-channel microphone preamp with a huge, richly-detailed sound, high-quality components, and a rugged 2RU chassis. It features a fully-balanced, transformerless design, a dedicated ribbon mic mode, built-in M/S decoding, and per-channel phantom power control and DI instrument inputs. There are dual parallel XLR outputs and a 2-color, bi-phase peak indicator for each channel.

- Dual parallel XLR outputs
- 4.5Hz-350kHz frequency response
- Rotary switch for 48V, Ribbon Mic or DI selection
- Ultra-low -130dB Noise
- 60dB Gain
- M/S Decoding with width control
- Precision gold-contact gain controls

**SOLID STATE LOGIC**  
**X-Rack Enclosure**

#SOXRE6  
**\$2045<sup>00</sup>**

The X-Rack is a 4RU rackmount housing and power supply accommodating up to 8 hardware EQ, mic pre, input and dynamics processing modules in the X-Rack modular system.

- Rackmount housing and power supply for X-Rack modular system
- Configurable as stand-alone mixer, processor, or analog summing unit for DAW's
- 4- and 8-input modules, XL 9000K dynamics module available for X-Rack
- Includes 6 blank face panels

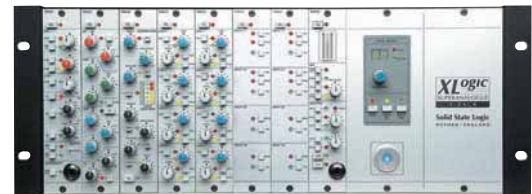

- 729621X1** Mic pre module #SOMPMXR..... **\$975.00**
- 729618X1** Dynamics module #SODMXR..... **\$975.00**
- 729625X1** EQ module #SOEMXR..... **\$975.00**



**GRACE DESIGN**  
**Model 101**

#GR101  
**\$565<sup>00</sup>**

The Model 101 is an elegant single-channel microphone preamplifier with a no-nonsense design and a very pure signal path. The simple, intuitive front panel is equipped with sturdy, easy-access phantom power and HPF switches, a Hi-Z instrument input, gain, and output trim controls, a 2-color bi-phase peak indicator, and a power switch with its own light.

- Lightning-fast trans-impedance amplifier
- 4.5Hz-390kHz frequency response
- Fully-balanced transformerless design
- 3-position HPF switch
- 60dB Gain
- 10dB output level trim controls
- Switchable 48V phantom power
- Capacitor-free signal path

**MACKIE**  
**ONYX 800R**

#MAO800R  
**\$1099<sup>99</sup>**

The Onyx 800R is an 8-channel 1RU microphone preamp designed with the unique ability to simultaneously output both analog and 24-bit/192kHz multi-format digital signals. Each channel offers dedicated Low Cut, Phase and Phantom power controls. The unit has an ultra-clean audiophile sound and delivers an astounding 123db of distortion-free dynamic range, ideal for direct DAW recording at today's extreme recording levels.



- XLR mic/line, dual 1/4" instrument DI
- 10Hz-170kHz mic-to-line out frequency response
- 10Hz-90kHz mic-to-AES out frequency response
- Variable mic impedance selector for Ch.1 and 2
- Variable 32Khz-192kHz sample rate selector
- 16 & 24-bit depth selector

**TRUE SYSTEMS****P2 analog**#TRP2A  
**\$1475<sup>00</sup>**

The P2 analog is a high performance 2-channel microphone/instrument preamplifier designed for critical recording applications. This rack mount unit features selectable M-S (mid-side) decoder, stereo phase correlation display, two mic inputs, two active high-impedance DI's, a high-pass filter and a polarity reverse selector. The totally balanced, dual-servo, dc-coupled design provides exceptional transient response, head room, and imaging.



- (2) XLR mic inputs, (2) 1/4" Hi-Z instrument inputs
- (2) XLR & (2) 1/4" TRS outputs
- Stereo Phase Correlation display speeds effective mic positioning
- M-S (mid-side) decoder for creative spatial image control
- Selectable 40Hz/80Hz high-pass filter
- Polarity reverse selector
- Dual gain range • 1U rack mount design



- Superior input sound quality and flexibility
- Hi-Z instrument input on channels 1-2
- (8) EQ channels, preamps, limiters, and 24-bit/96k converters
- High-quality upgrade and sonic performance over stock input systems

- Superior input sound quality and flexibility
- Hi-Z instrument input on channels 1-2
- (8) EQ channels, preamps, limiters, and 24-bit/96k converters
- High-quality upgrade and sonic performance over stock input systems

**Digimax LT** same as Digimax 96k with the following exceptions: all channel inputs on Neutrik XLR combo jacks, inserts for each input, ADAT digital connect only, 48k A/D, no enhancing EQ #PRDMLT.....**\$799.95**

**Digimax FS** #PRDMFS .....**\$599.95**

**PRESONUS****Digimax 96k**#PRDM96  
**\$1329<sup>95</sup>**

The Presonus Digimax is an uncompromisingly well-built 8-channel mic preamp that represents a significant upgrade to the front-end of any computer-based recording system. Its transformerless design, combined with eight mic preamps, A/D's, limiting, and subtle switchable enhancing, produces an overall warmer tone with greater definition and dynamic range resulting in superior sound for almost any connected source.

**FOCUSRITE****ISA-828**#FOISA828  
**\$2499<sup>99</sup>**

The ISA-828 is an 8-channel rackmount microphone preamplifier, loaded with Focusrite's original transformer-based ISA preamp modules offering high-headroom transparency. The unit features a 4-setting variable-impedance input stage with 80dB of maximum gain, and capably handles both high-output condensers and low-output ribbon mics. Channels 1-4 include DI instrument inputs as well. The ISA-828 is a versatile studio front-end with an affordable high-end sound.



- 8-channel rackmount microphone preamp
- Microphone and line inputs on all channels
- Hi-Z instrument inputs for channels 1-4
- 80dB of gain for mic inputs
- 75Hz HPF, 48V phantom and phase switches
- Variable microphone impedance with 4 settings
- (8) XLR mic, (8) 1/4" TRS phone line, (4) 1/4" TS phone inputs
- (1) 25-pin D-sub 8-channel output

- (1) XLR input & output
- Classic Putnam 610 console Mic Preamplifier and DI
- Legendary all-tube sound at a project studio price
- Gain, Level, and impedance selection for maximum tonal variety
- DI features like Thru and Mic/Line level output
- Ground lift switch
- Rugged steel chassis
- Internal switching power supply
- Hand assembled in the USA

**UNIVERSAL AUDIO****Solo/610**#UNS610  
**\$799<sup>00</sup>**

The SOLO/610 is a single-channel tube microphone preamp & DI box that delivers the classic Putnam 610 console sound in a portable, form factor case. This highly versatile unit offers 48V phantom power, low-cut filtering, phase reverse; and for even greater tonal variety, maintains the 610's flexible dual impedance selection for both Mic and DI inputs.

**UNIVERSAL AUDIO****Solo/110**#UNS110  
**\$799<sup>00</sup>**

The Solo/110 Precision is a Class-A microphone preamp & DI box that delivers the "ultra fidelity" and tonal variety of UA's flagship Precision 110 series mic preamplifiers in a rugged, portable, form factor case. This single-channel unit offers 48V phantom power, low-cut filtering, phase reverse; and for even greater tonal variety, maintains the Precision's flexible dual impedance selection for both Mic and DI inputs.

- (1) XLR input & output
- All Discrete Mic preamplifier & DI
- World-class "ultra fidelity" mic pre at project studio price
- Gain, Level, and impedance selection for maximum tonal variety
- DI features like Thru and Mic/Line level output
- Ground lift switch
- Rugged steel chassis
- Internal switching power supply
- Hand-assembled in USA





**FOCUSRITE**  
**Voicemaster Pro**

#FOVMP  
**\$649<sup>99</sup>**

The Focusrite Voicemaster Pro is a comprehensive vocal/instrument recording channel with features tailored for vocals, but still capable of impressive results on instruments, especially guitar. Project studios will appreciate the extensive tone shaping tools and processing versatility rarely found in a preamp channel of this class.



- Class-A preamp • Quiet, flexible operation and tonal coloration • Vintage Harmonics adds shimmer and light breathiness • Voice optimized EQ and De-esser
- Quick responding yet musical Optical Compressor and Expander
- 1/4" instrument and XLR mic inputs/optional digital output with clock sync up to 96kHz



- Dual servo, high dynamic range, transformerless design
- (1) XLR mic input, (1) 1/4" Hi-Z instrument input • XLR & 1/4"TRS output
- High-pass filter and 48V phantom power
- Over-size volume control with selectable 10db input level attenuation • 4-level metering
- Internal linear AC power supply
- Compact, portable, desk-top case

**TRUE SYSTEMS**  
**P-Solo**

#TRPS  
**\$595<sup>00</sup>**

The P-Solo is a precision single-channel microphone/instrument preamplifier that offers the same design and sound of the TRUE Systems Precision 8 and P2 Analog preamps in a compact desk-top case. It is equipped with XLR mic input, a front-panel high-impedance instrument input, an oversized volume control, a high-pass filter and four-level metering.

**SUMMIT**  
**2BA-221**

#SU2BA221  
**\$629<sup>00</sup>**

The 2BA-221 Mic and Line Module is a continuously variable impedance microphone preamp with microphone level, line level, and Hi-Z instrument inputs. It utilizes separate and individually-controlled solid state input controls to mix the microphone input with the Hi-Z or line input into the variable vacuum tube output. This versatile unit offers exceptional sonic control of mic, line, or instrument level.



- XLR and 1/4" outputs and inputs, insert jack
- Three variable, independent gain stages
- Separate solid state and tube outputs
- Variable High-pass Filter
- Variable Mic input impedance from 100 ohms to 10K ohms • Hi-Z input and Mic input available simultaneously with separate gain controls • Half-rack chassis



**SUMMIT**  
**TD 100**

#SUTD100  
**\$449<sup>00</sup>**

The TD-100 is a hybrid signal path instrument preamp/tube direct box that utilizes both a discrete solid state output device & a 12AX7A/ECC83 vacuum tube. It gives your musical instruments the clarity of Class-A sound with the richness and warmth of vacuum tubes in a compact, half-rack case. This high-quality unit is ideal for both live and studio use.

- Variable input impedance from 10K ohms - 2M ohms • XLR mic level output
- 1/4" TRS line level output
- Headphone output
- Signal ground lift & Polarity switch
- Internal high voltage power supply

**PRESONUS**  
**Eureka**

#PREUREKA  
**\$499<sup>95</sup>**

Eureka is a high-quality channel strip that combines a discrete Class-A, high-headroom Microphone Preamp with a Compressor and a 3-band Equalizer. This well-built, high-performance channel strip gives users all the sonic performance and control needed for professional audio recording at an affordable price.



- Microphone, Line, and Instrument inputs on XLR and 1/4" TRS connectors
- 3-band fully-parametric EQ
- Variable Saturate Control—simulates Tape Saturation and Tube Warmth
- Balanced Send and Return
- Fully-variable Compressor with Hi-pass side chain
- Hard and soft knee compression
- Illuminated VU meter

**AD192** Optional 24-bit/192k Digital Output Card #PRAD192 ..... **199.95**

## APHEX 230

#AP230  
**\$699<sup>00</sup>**

The Aphex 230 is a versatile, 1RU tube-based microphone preamp and voice processor, appropriate for use in broadcast production, voice-over, and higher-end podcasting. The processor complement includes a compressor and gate, a variable frequency de-esser, a parametric EQ, and Aphex's popular Exciter and Big Bottom enhancers. The 230 is equipped with an A/D converter which offers multi-format simultaneous output, along with a Word Clock I/O.



- 18Hz-24kHz frequency response
- 20dB to 65dB Gain Range
- AES/EBU, Coax and Optical SPDIF outputs
- Low-jitter Word Clock I/O
- Reflected plate tube mic pre
- Inserts between dynamics and EQ processors
- Cough switch for on-the-fly muting



## RME OctaMic

#RMOCTAMIC  
**\$899<sup>00</sup>**

The OctaMic is a 1RU 8-channel microphone and line preamplifier with a discrete, Class-A design, allowing for the connection of virtually any mic to a line level input. Each channel is equipped with 48V phantom, phase reverse, and low-cut filter switches. The unit is guaranteed for 100% hum-free operation, and is equipped with RF input filters for wider frequency response. For mobile operation, the OctaMic can be powered via a rechargeable lead battery.

- 10dB to 60dB Gain Range
- 5Hz-200kHz frequency response
- XLR combo inputs, TRS phone outputs
- Rechargeable lead battery operation
- +4dBu/-10dBv switchable reference level
- Servo-balanced ins and outs
- Studio or mobile truck recording applications

## JOEMEEK oneQ

#JOONEQ  
**\$659<sup>99</sup>**

The JOEMEEK OneQ is a single-channel microphone preamp and channel-strip processor combining a 4-band parametric EQ, an optical compressor, a de-esser and an Enhancer, housed in a solid 2RU chassis. The JOE MEEK sound, particularly the compressor, is often characterized as "fat," "aggressive," "punchy," and "tube-like;" if you'd like to add some old-school analog beef to your digital tracks, the OneQ delivers.



- Classic analog sound
- 15Hz-70kHz frequency response
- Variable 10dB to 60dB Gain range
- Optical and Coaxial SPDIF digital connectors
- A/D interface with a Word Clock I/O, AES/EBU
- Fast aggressive optical compressor
- Musical EQ for tone control
- Large backlit VU meter



## JOEMEEK sixQ

#JOSIXQ  
**\$449<sup>99</sup>**

The JOEMEEK SixQ is a single-channel microphone preamplifier equipped with an aggressive, lightning-fast optical compressor and a musical 3-band EQ. Also housed in the rugged 1RU chassis is a 24-bit/96kHz-capable A/D converter, a nice complement to the thick, in-your-face presence of the unit, allowing some classic analog warmth and size into one's digital recording.

- 15Hz-70kHz frequency response
- Variable 10dB to 60dB Gain range
- 24-bit A/D converter
- Selectable sample rates to 96kHz
- Optical and coaxial SPDIF digital outputs
- XLR and 1/4" TRS, TS phone analog ins and outs
- Musical EQ with HF shelving, sweepable mids and lows
- Classic analog sound

## FOCUSRITE Twin Trak Pro

#FOTTP  
**\$599<sup>99</sup>**

The Twin Trak Pro is a 2-channel microphone preamplifier equipped with a dual-mono/stereo optical compressor and an EQ section consisting of a High-pass Filter and a Mid-scoop. The unit represents an affordable way to bring some Focusrite class to project studio tracking. Features such as front panel XLR and 1/4" connectors, attractive metering, and variable input impedance allow for quick setup and creative flow when the mood strikes.



- 10Hz-200kHz frequency response
- 60dB Gain Range
- Latency-free monitoring
- 24-bit A/D converter, Word Clock I/O
- Selectable sample rates to 192kHz
- Out Switch removes unused compressor and EQ from signal
- "Air" function for greater HF openness

**DBX**  
**376**#DB376  
**\$499<sup>00</sup>**

The 376 from DBX is a channel strip featuring a single-channel tube microphone preamp, 3-band parametric EQ, a compressor and a de-esser, housed in a 1RU steel chassis. The 376 includes an A/D converter with selectable sampling and bit rates, supporting AES/EBU and SPDIF digital formats, and a Word Clock I/O. Flexible and warm-sounding, the 376 is a good value.



- Tube mic pre
- XLR and 1/4" mic and Hi-Z inputs
- AES/EBU, RCA SPDIF digital outs
- 10Hz-75kHz frequency response
- 60dB maximum Gain
- Selectable sampling and bit rates
- BNC Word Clock I/O
- Selectable dither and noise-shaping algorithms

**SYMETRIX**  
**528E**#SY528E  
**\$499<sup>00</sup>**

The 528E is a 1RU single-channel microphone preamp and multi-function voice processor that performs the functions of six separate pieces of studio gear. It is equipped with a compressor/limiter, de-esser, downward expander, a 3-band parametric EQ, and a voice symmetry alignment function, which further corrects for the natural peaks and dips of human vocal delivery. All processing may be implemented simultaneously, if necessary.

- Replaces six pieces of studio gear
- XLR and 1/4" inputs and outputs
- 20Hz-20kHz frequency response
- Up to 60dB Gain
- Very low -126dBV noise
- Works with all microphones including ribbon
- Simultaneous use of all six processors
- Separate metering for mic gain and dynamics processing

**FOCUSRITE**  
**TrakMaster Pro**#FOTMP  
**\$299<sup>99</sup>**

The TrakMaster Pro is a single-channel microphone preamplifier and signal processor. The unit houses the mic pre, an optical compressor, and a mid-scoop EQ in a handsome 1RU metal chassis. The TrakMaster Pro is an excellent solution for mono vocal or instrument tracking in a professional or project studio, with professional connectivity, high headroom, and latency-free monitoring.



- 20Hz-250kHz frequency response
- Up to 60dB Gain
- Single-channel mic preamp/signal processor and DI
- Fast optical compressor
- Mid-scoop EQ with dual cut depths, adjustable frequency
- High-pass filter
- XLR and TRS phone input and output connectors

**DBX**  
**286A**#DB286A  
**\$199<sup>95</sup>**

The 286A is a single-channel microphone preamplifier containing 5 independent and combinable signal processors, including a compressor (a dbx specialty), de-esser, Enhancer, and an expander/gate. The unit serves as a versatile, and inexpensive voice processor for studio vocal, broadcast, and voiceover applications, with professional connectivity and controls, and a clean sound.

- XLR and TS phone inputs
- 20Hz-20kHz frequency response
- Up to 60dB Gain
- Overeasy compressor, frequency-tunable de-esser
- Enhancer for vocals and instruments
- Expander/Gate reduces headphone leakage, guitar amp noise
- TRS phone output, insert

**STUDIO PROJECTS**  
**VTB1**#STVTB1  
**\$119<sup>99</sup>**

The VTB-1 is a single-channel tube microphone pre-amplifier and DI, designed as a low-cost alternative for project studio owners and voiceover artists desiring the tube sound. The unit features a Tube Drive control knob that attenuates or increases the amount of tube circuitry in the signal path according to taste, delivering both solid state transparency and tube thickness.



- Low-cost tube mic pre with readily available 12AX7 tube
- XLR and TRS phone inputs, outputs, & insert
- High-pass filter
- 20Hz-20kHz frequency response
- 72dB Gain range
- Tube Drive controls tube presence in signal path
- Buffering for Hi-Z in avoids pickup loading for guitars, basses



## M-AUDIO Octane

#MA0Q  
**\$599<sup>00</sup>**

The Octane is a highly flexible preamplifier interface ideal for anyone using ADAT inputs. It features eight channels of dynamic low-noise, high-gain pre-amplification on balanced XLR, TRS, or high-impedance instrument-level inputs. Each channel provides a separate microphone level, 20dB pad, and three segment LED meter, with output connections being made via balanced/unbalanced 1/4" line or ADAT lightpipe.



- Low-noise, high-gain 8-channel microphone/instrument preamp
- (8) XLR, 1/4" balanced/unbalanced inputs

- (2) Hi-Z (guitar) instrument inputs on channels 1-2
- ADAT lightpipe, 1/4" direct outs
- Word clock I/O • 24-bit A/D



## M-AUDIO DMP3

#MADMP3  
**\$159<sup>00</sup>**

The DMP3 is an ideal two-channel microphone/instrument pre-amplifier for high resolution recordings. Its exceptional 20Hz to 80kHz dynamic range is complemented by an unbelievable 66dB of gain, VU meters and phantom power for condenser microphones. Every nuance of your sound source will be recorded with minimal noise or degradation improving overall recording quality.

- 2-channel mic/instrument pre-amp
- XLR mic and 1/4" instrument inputs
- 1/4" balanced outputs

- High gain and low-cut switches with 66dB of total gain
- 48V phantom power
- 20Hz-80kHz frequency response

## PRESONUS BlueTube DP

#PRBTPD  
**\$199<sup>95</sup>**

The BlueTube DP is an affordable two channel microphone/instrument preamp with the flexibility to deliver a variety of tones. Each channel has the ability to bypass the tube circuit for a clean response, or saturate the tone by engaging the tube drive knob and adjusting it to your liking. Illuminated analog VU meters and professional features like phantom power and Neutrik connectors make it an excellent addition to home and project studios.



- Signal to noise ratio of 95dB
- 20dB pad, polarity reversal, and 80Hz low-cut filter buttons
- Excellent for microphones and as a DI for guitar and bass

- Acts as a solid state and tube driven preamplifier
- Neutrik combo inputs, XLR and 1/4" outputs



## SYMETRIX 302

#SY302  
**\$279<sup>00</sup>**

Featuring a straightforward design, the Symetrix 302 is an extremely low noise, highly transparent two-channel microphone preamp with solid stereo imaging and an excellent transient response delivering superior sonic improvements over stock mixer/console preamps. Capable of a total gain range of 75dB, the 302 also provides phantom power, 15dB pads, and reverse polarity switches per channel.

- Ideal for Broadcast, Sound Reinforcement and other studio applications
- Superior stereo imaging
- 3dB below clip LED's

- Balanced XLR inputs
- Balanced Euroblock output connectors with 24dBm max. output
- Balanced/unbalanced TRS outputs

## JOEMEEK threeQ

#J0THREEQ  
**\$229<sup>99</sup>**

The threeQ is a single-channel microphone/instrument preamp with an extremely musical EQ section and an optical compressor that delivers the signature "Meek" sound. This affordable, compact channel strip uses the same Burr-Brown IC's for the mic pre that you'll find on their more expensive studio channels. The threeQ also provides an insert point for patch processors into the signal chain.



- (1) XLR input with 48V phantom power
- (1) 1/4" line input
- (2) 1/4" TRS outputs
- Insert point for external processors

- 3-band EQ section with semi-parametric mids
- Optical Compressor
- Front panel LED metering
- Compact half-rack chassis

### ART TPS II

#ARTPSII  
**\$185<sup>00</sup>**

The TPS II is a two-channel tube preamp/direct box designed with optimized reference points for specific recording applications. Each channel of the TPS II provides variable impedance control, phantom power, overload limiting, and dual analog level monitoring. A "Swiss army knife" for project and professional studios alike, the versatile TPS II is also ideal for broadcast, remote, and commercial applications.



- Variable impedance provides multiple tone adjustments of varying microphone types
- Variable Valve Voicing reference points
- Clean transformerless signal path with wide dynamic range
- Enhanced OPL Output Protection Limiter
- Dual analog level monitoring on LED's and VU
- Phase, gain, and phantom switches per channel
- Dual front panel Neutrik XLR combo jacks
- Balanced XLR I/O, balanced/unbalanced TRS I/O



### ART Tube PAC

#ARTUBEPAC  
**\$129<sup>00</sup>**

The Tube PAC is a combination amplifier & optical tube compressor with a compact table-top chassis. It provides over 70dB of gain, 48V phantom power, phase reversal, and its 12AX7 tube stage warms up any instrument or microphone. Threshold, compression/limiting ratios, adjustable release times, bypass, gain reduction metering, and output gain controls are provided.

- Combination Tube Preamplifier and Tube Compressor
- 48V Phantom Power
- (2) Hand-selected 12AX7 vacuum tubes
- Tube DI Box for instruments
- Precision detented potentiometers
- LED level indicators
- Balanced XLR and unbalanced 1/4" inputs and outputs
- By-passable compressor circuitry

### M-AUDIO Audio Buddy

#MAAB  
**\$79<sup>95</sup>**

The Audio Buddy is a cost-effective two-channel preamp/direct box for microphones or high-impedance instrument lines. The compact unit's front panel features individual gain control and clip LED's with 1/4" inputs, while providing dual balanced XLR inputs with a phantom power switch on the rear. A clean and simple tool to use, the Audio Buddy is an ideal preamp/direct box for home studios.

- Compact 2-channel instrument/mic pre with up to 60dB gain
- Ideal for use as a direct box
- Individual gain control with clip LED's
- 1/4" and XLR inputs with balanced/unbalanced 1/4" outputs
- Phantom power



### ART Tube MP Project Series

#ARTMPPS  
**\$69<sup>00</sup>**

Improving virtually every aspect of the already popular Tube MP, the Tube MP Project Series is an ultra-low-noise discrete mic preamp that effectively handles a wide range of input signals with minimal coloration. Its 1/4" and XLR inputs pass through a high-quality 12AX7 tube, selectable filters, and a musical FET limiter, providing a dynamic 70dB of gain while preserving signal tonality and clarity.

- Low-noise, tube mic preamp
- Fast FET limiter helps limit overload
- Phase invert and filter switches
- Switch selectable input impedance
- Variable I/O controls
- 48V phantom power

### BEHRINGER Tube Ultragain Mic 100

#BEMIC100  
**\$39<sup>99</sup>**

The Tube Ultragain Mic 100 is a vacuum tube mic/line preamplifier with an integrated limiter designed for studio, live, and hard disk recording applications. It provides balanced inputs & outputs, phase reverse switch, 48V phantom power and a 20dB pad and can also be used as a high-quality DI. The 12AX7 tube stage warms up vocals, instruments, and digital recordings.

- Tube mic/line preamplifier & limiter
- Balanced inputs & outputs on 1/4" TRS & XLR connectors
- 48V phantom power
- Hand-selected 12AX7 vacuum tube with UTC technology
- Phase reverse switch, and 20dB pad
- Highly accurate 8-segment LED level meter



**ION**

**Tape 2 PC USB**

#IOTAPE2PC  
**\$139<sup>95</sup>**

Are you looking for a way to transfer your cassette tapes onto a computer and into an iPod or another MP3 player? Your search is over! The Tape 2 PC from Ion is a dual cassette player/recorder that has a digital USB output that connects directly to your computer. It comes with recording software for Mac and PC that takes the hassle out of capturing your tapes onto your computer's hard drive.

- Easiest way to archive cassettes to a computer
- Metal and CrO2 tape compatible
- Includes EZ Tape Converter 2 for PC
- Includes EZ Audio Converter for Mac
- Includes Audacity software for Mac and Pc to clean up the sound
- Red and white stereo RCA cable and USB cable included



- Twin IC logic control mechanisms
- Dual auto-reverse tape transports
- Variable pitch control +/- 10%
- CPS Computomatic Program Search
- Auto tape type selector
- Mic/line mixing recording

**TASCAM**

**W-865R/TAS**

#TAW865RTAS  
**\$214<sup>95</sup>**

This dual auto-reverse cassette deck is simple, cost effective, and offers an impressive variety playback and record options for such a modestly priced unit. The layout is sleek and straightforward with an easily readable multi-function fluorescent display and dual 4-digit electronic tape counters. It offers normal and high-speed dubbing, parallel recording, and both decks have Dolby B noise reduction with dual auto-reverse and Synchro reverse dubbing. There is also a dedicated microphone input with its own level control adding to its versatility.

**TASCAM**

**322**

#TA322  
**\$499<sup>00</sup>**

The 322 is a rack-mountable, dual well, bi-directional cassette deck designed for logging and long-form recording. Ideal for music studios, boardrooms, houses of worship, and live venues, the 322 uses optical leader sensing for quick auto reverse, minimizing the time lost when switching sides. Each well offers independent audio input and output, and a RS-232 port allows serial control of the deck from various control systems on the market.

- Independent unbalanced analog I/O for each deck
- Return-to-zero function on each deck
- ±10% pitch control independent for each deck
- Normal and high (2x) speed dubbing
- Headphone output with level control
- Optional LA-322 balancing kit and WR-700 cascade cables



- 3-space rackmount dual cassette deck with full-logic auto-reverse
- Auto music search function
- Normal and high-speed synchro dubbing
- Relay playback and blank skip/blank recording features

**INTER-M AMERICAS**

**PC-9335AD**

#INPC9335AD  
**\$558<sup>50</sup>**

The PC-9335AD is a mid-priced professional rackmount dual cassette deck featuring full-logic auto-reverse and auto music search functionality. Designed for installation and tape-dubbing applications, the unit offers real-time and high-speed dubbing, relay playback, Digi-Link multi-unit synchronization, and sturdy front handles for quick removal. The deck also offers full record-level control, with both blank skip and blank recording features.

**RECORDEX**

**Stereo Cassette Duplicators**

Available in four different configurations, the Recordex stereo cassette duplicators are 1/4 track, four-channel recorders that can produce 1, 2, 4, or 8 copies (dependent on the model) from a master cassette at 16 times normal speed. Features include: extra long life T-core stereo heads, erase head, individual audio level controls with peak level, LED indicators, auto copy cycle, switching power supply, and steel construction.

- Messenger 1-to-1 duplicator #REM** ..... **\$339.00**
- Sound Master II 1-to-2 duplicator #RESM2**..... **\$749.00**
- Sound Pro 1-to-4 duplicator #RESP**..... **\$999.00**
- Sound Master IV 1-to-4 duplicator with expansion option #RESM4**.. **\$1399.00**
- Sound Master IV Expansion (4) cassette expansion option #RESM4E**..... **\$1399.00**





## DENON DN-780R

Denon's DN-780R is a professional rackmount dual-well cassette deck with independent inputs and outputs for each well. The unit features dual auto-reverse, pitch control, and a 1/4" headphone output with volume control and a deck monitoring selector switch. The DN-780R is a versatile unit and an outstanding value for use in studio and installation applications.

#DEDN780R  
**\$619<sup>00</sup>**



- Full-featured professional 3-space rackmount dual cassette deck
- Independent inputs and outputs for each well
- Dual auto-reverse, +/-12% pitch control
- HX Pro, Dolby B/C noise reduction
- (2) RCA I/O's per well, 1/4" Mic input
- 1/4" Headphone out with volume control and deck selector



- CD deck supports MP3 file playback
- MD deck supports Stereo, Mono, LP2, and LP4 mode (REC/Play)
- Unbalanced analog I/O (RCA), digital S/PDIF (optical) – both decks
- Pitch control: CD deck  $\pm 16\%$ , MD deck  $\pm 12.5\%$
- Full edit functions on MD deck
- Wireless remote, transport control via PS/2 keyboard

## TASCAM MDCD-1

#TAMDCD1  
**\$799<sup>00</sup>**

The MDCD-1 combines CD playback and MiniDisc recording in a single rack-mount unit which conserves space and installation budgets. Each unit can be used independently and features its own digital and analog I/O. Change pitch without changing tempo and change tempo without changing pitch, all while burning CD's to the MiniDisc at 4x speed. Ideal for DJ's, houses of worship, and institutional (music education) installs.

## TASCAM MD-350

#TAMD350  
**\$489<sup>00</sup>**

The Tascam MD-350 is a professional rack-mountable stereo MiniDisc recorder with balanced analog I/O, and optical S/PDIF I/O. The latest ATRAC encoding scheme (ver. 3) is implemented, offering new long play versions with up to 320 minutes of record time on a standard 80 minute MiniDisc. The affordable MD-350 is ideal for live venues, houses of worship, and broadcast applications.



- Balanced XLR and unbalanced RCA analog I/O
- Optical S/PDIF I/O w/front panel optical Input
- Auto Ready and Auto Cue functions
- Front Panel PS/2 keyboard port for naming track
- Complete TOC editing for changing track order
- Headphone output w/level control
- Pitch control



- Balanced XLR line inputs with trim, unbalanced RCA I/O
- Menu driven remote operation
- Coaxial S/PDIF I/O
- 16–48kHz sample rate and 32–384-bit rate selectable
- Security door for media
- Computer I/O for rapid file transfer

## MARANTZ PMD570

#MAPMD570  
**\$899<sup>00</sup>**

The PMD570 is a professional solid state recorder ideal for installation applications like houses of worship, corporate boardrooms, and schools. Designed to replace traditional cassette recorders, the PMD570 records directly to inexpensive compact flash cards in MP3, MP2, .WAV, and BWF format. Easy one-touch recording, RS-232c control, and no moving parts make this reliable recorder a great solution for long-term audio installations.

## TASCAM DV-RA1000HD

#TADVRA1000HD  
**\$1999<sup>00</sup>**

The DV-RA1000HD is high-resolution stereo digital recorder capable of capturing audio at sampling rates up to 24-bit/192kHz. It also features an internal 60GB hard drive for up to 60 hours of recording time, making it perfect for live applications. The DV-RA1000HD records standard CD-DA, .WAV, and DSDIFF files to DVD+RW and CD-R/RW media, and provides professional I/O via XLR, AES-EBU, and SDIF-3 connections. Equally well-suited for today's recording and broadcast studios, the DV-RA1000HD is easy to use, and has advanced features like a USB2.0 port, RS-232 serial control, multiband compression, and EQ.



- Balanced XLR and unbalanced RCA inputs and outputs
- Large, backlit LCD display
- Word Clock Sync in, out, and thru
- USB 2.0 connection to PC for use as DVD data drive
- Can also operate as a professional CD recorder
- Supports Sony's DSD recording format
- Wired remote control (RC-RA1000) included

**ROLLS**  
**HR78**

#ROHR78  
**\$173<sup>95</sup>**

The Rolls HR78 is a digital AM/FM tuner with an unusual 1/2-space/2RU rack-mount design, intended for use in space-limited rack installations. The unit provides 18 station presets with instant recall, a large backlit display, and the convenience of side-by-side installation in the event that two units are being routed to separate areas of the same building.

- 1/2-space 2RU rackmount digital AM/FM tuner for installations
- Stereo RCA outputs and 1/8" stereo mini headphone output
- 18 user-selectable presets
- Dual 75-Ohm FM and 300-Ohm AM antennas supplied



- HR72** CD/MP3 player version #ROHR72..... **\$298.95**
- HR73** MP3 player/recorder version w/1/4" mic inputs #ROHR73...**\$299.95**
- HR31** Rack ear set for HR series #ROHR31.....**\$39.95**



- 1RU PLL-synthesized quartz digital AM/FM tuner
- 40 presets with automatic search-and-store function
- LED signal strength meter
- XLR, RCA and headphone outputs
- IR remote control included

**ROLLS**  
**RS80**

#RORS80  
**\$259<sup>95</sup>**

The RS80 is a 1RU quartz PLL-synthesized digital AM/FM tuner housed in a rugged steel chassis intended for installation use. The units stores up to 40 station presets and is equipped with a large, clear LCD readout display. The unit is designed for international use, featuring a switchable 120/230V power supply and programmable 9-10kHz AM centers switching, which allows for channel access in both the U.S. and Europe or Asia.

**DENON**  
**TU-1500RDP**

#DETU1500RDP  
**\$359<sup>00</sup>**

Denon's TU-1500RDP is a 2RU rackmount AM/FM tuner with a sleek, professional appearance and a high-rigidity, vibration-resistant top cover. The unit's pro-level features including 40 programmable station presets, low-impedance output circuitry for optimal sound clarity, and a variety of Radio Data System functions supported by Radio Text implementation.

- Professional rackmount digital AM/FM tuner
- Microprocessor in tuning circuit eliminates reception drift
- Dot Matrix display with Radio Text support
- Radio Data System functions include song titles and station messages
- Rotary knob for speedy, precise control



- 2RU iPod music player and docking station for fitness instructors and installations
- XLR and RCA stereo outputs
- Oversized front panel controls and IR remote control
- MixMeister Express software included for custom edits and mixes
- All-steel chassis

**NUMARK**  
**Fit-for-Sound**

#NUFFS  
**\$259<sup>95</sup>**

The Fit-for-Sound is a rugged 2RU rackmount iPod music playback unit designed for use by gym, dance and aerobics instructors, or as a professional bar and restaurant installation component. The unit is equipped with an iPod docking station, oversized transport and selection wheel controls, and MixMeister Express mixing and editing software for easily-achieved custom mixes.

**NUMARK**  
**MP102**

#DETU1500RDP  
**\$359<sup>00</sup>**

The MP102 is a professional rackmount CD player for DJ's and sound reinforcement applications. The unit is compatible with Red Book CD's, CDR's and MP3 audio CD formats, while featuring an interactive pitch wheel, a DJ-style pitch fader with a +/-8 or 16% range, and a large backlit LCD display.

- 2RU rackmount CD player for DJ's and FOH engineers
- Direct track access with sequence programming
- Buffered anti-shock protection
- 2 seamless and 3 hot-stutter starts
- Balanced XLR and unbalanced RCA analog outs, SPDIF digital output



**MP302** dual-deck version with remote #NUMP302...**\$499.95**

**AUSTRALIAN MONITOR**  
**BGM2-TCD**

#AUBGM2TCD  
**\$519<sup>00</sup>**

The BGM2-TCD is a 1RU rackmount combination AM/FM tuner and programmable CD player with MP3 compatibility. The tuner offers separate Am and FM bands with 10 selectable presets and the CD player features 20-track programmability and several playback functions. There are dedicated RCA stereo outputs for each module in addition to a priority stereo output.



- 1RU combo unit with AM/FM tuner and CD/MP3 player
- Separate displays and dedicated stereo RCA outputs for each module
- Tuner Sleep function
- Random track selection for CD's
- Repeat-single and repeat-all functions for CD's and MP3's



**INTER-M AMERICAS**  
**CD-610**

#INCD610  
**\$348<sup>95</sup>**

The CD-610 is a slot-loading 2RU rackmount CD player offering a feature set designed for installation in restaurants, retail spaces, professional offices and houses of worship. The deck plays back both MP3 and WMA files in addition to standard Red Book and CD-DR/RW CD's, and the chassis rear is equipped with both XLR and RCA outputs, alongside a control port with full AMX and Crestron functionality.

- 2RU slot-loading CD player with MP3 and WMA file CD playback
- Large VFD display and intuitive user interface
- Front panel headphone output with dedicated volume control
- XLR and RCA analog outputs, optical and coaxial digital outputs
- Wireless IR remote control, AMX/Crestron control port

**CD-660 6-CD changer version #INCD660.....\$558.95**

**BOGEN COMMUNICATIONS**  
**DCM290P**

#BODCM290P  
**\$447<sup>95</sup>**

The DCM290P is a handsome 5-disc CD changer for the home or studio use featuring MP3 and WMA decoding and disc load and removal without interrupting play mode. The unit includes a rackmount kit and offers up to 32-track programmability from 5 separate discs. Stereo RCA analog outputs are provided in addition to both coaxial and optical digital outputs.



- 5-disc CD changer with digital outputs
- MP3 and WMA file decoding and CD playback
- Multi-level jitter-removing noise shaping DAC
- 3-mode random playback feature
- Synchro recording support



**INTER-M AMERICAS**  
**PT-9107SD**

#INPT9107SD  
**\$335<sup>95</sup>**

The PT-9107SD is a 1RU rackmount digital AM/FM tuner designed for installation use in restaurants, offices and supermarkets. It is equipped with both mono and stereo outputs for compatibility with a variety of systems, and a clear multi-function display. The unit offers 20-preset capability and a Digi-Link function for remote control.

- 1RU installation AM/FM tuner
- Fixed and variable outputs with separate connectors
- Station auto-scan function
- Easy-access control and selector buttons
- AC and DC power connector

**TU-610 2RU professional version w/XLR and Crestron connectors #INTU610.... \$398.50**

**TOA ELECTRONICS**  
**DT-930**

#TODT930  
**\$421<sup>50</sup>**

The DT-930 is a 1RU rackmount synthesized AM/FM tuner designed for installation use in background and foreground music systems for bars, restaurants, hotels and public spaces. The unit features digital tuning for consistently reliable reception, and offers 40-preset access to selected favorite stations. The clear, bright, backlit display and simple, easily-navigated control set allow for quick station entry and selection in either band.



- Rackmount AM/FM tuner for installations
- Stereo and Mono RCA outputs
- 40 programmable channel presets
- Multiple station select options include manual, auto, and direct frequency entry
- Automatic Preset Tuning scans and stores frequencies into preset memories



## HBB CDR 882

#HBCDR882  
**CALL**

The CDR 882 is a professional dual-drive CD recorder featuring an all-steel chassis, audiophile sound quality, and comprehensive analog and digital connectivity options including Word Clock input. The unit offers high-speed CD duplication, simultaneous recording of 2 separate discs, and 24-bit A/D and D/A conversion with noise-shaped dither to CD. The CDR 882 suits a variety of pro applications including broadcast, music production, and live sound, lecture or houses of worship recording.



- Dual-drive rackmount CD recorder
- AES/EBU and SPDIF digital I/O
- XLR and RCA analog connectors
- Word Clock input
- Noise-shaping for minimized quantization error noise from 24- to 16-bits
- High-speed disc duplication



## FOSTEX CR500

#FOCR500  
**\$499<sup>00</sup>**

The CR500 from Fostex is a powerful master CD recorder and playback machine. It's capable of recording BWF (broadcast WAV files) with up to 96k 24-bit resolution directly to a UDF (Universal Disk Format – Windows only) CD. It features versatile functionalities as a CD player as well that are useful in theatrical sound design and other production settings, such as 100 built-in memory cue points per CD, instant play and more.

- Balanced XLR and unbalanced RCA inputs and outputs
- AES/EBU or S/PDIF digital inputs and outputs
- Up to 96k 24-bit resolution as well as standard 44.1 16-bit
- Power on play, fader start
- USB port for standard keyboard titling
- 10 memory point per disc, 100 cue points
- 10.6 lbs, 19 (W) x 3.68 (H) x 12.6 (D)

## ALESIS ML9600

#ALML9600  
**\$799<sup>00</sup>**

The ML9600 is a high-resolution two-track Hard Disc recorder and CD burner capable of 24-bit/96kHz audio capture and archiving. This "Mastering House in a Box" allows you to edit tracks, apply DSP, and burn the finished recording in either the industry-standard Red-book or the new high-resolution CD24 format.

- Onboard Processing including: Parametric EQ, Compression, Limiting, and Normalizing
- 40GB hard drive allows up to 30 hours of 2-track audio
- Balanced I/O on XLRs, unbalanced I/O on RCAs



- Organize playlists with total control of fade-ins, fade-outs, track gain, start points, and track cropping
- AES/EBU and Coaxial S/PDIF I/O
- Internal switching power supply



## TASCAM CD-RW901SL

#TACDRW901SL  
**\$899<sup>00</sup>**

Tascam's CD-RW901SL is a professional slot-loading rackmount CD recorder. The unit is equipped with 24-bit converters and supports both CD-RW and MP3 CD playback. The deck offers advanced features such as sample rate conversion, parallel and RS-232C control ports for broadcast or installation remote control applications, pitch control, and selectable disc reading speed.

- Professional rackmount slot-loading CD recorder with MP3 playback support
- 24-bit A/D and D/A converters
- Oversized display, front panel headphone output with volume control
- CD-Text and MP3 ID3 tag display
- XLR and RCA analog I/O's
- Toslink optical, SPDIF coaxial and AES/EBU XLR digital I/O's
- Multiple playback and cue features

## ROLAND CD-2e

#ROCD2E  
**\$599<sup>00</sup>**

The CD-2e is a portable stereo CD and SD flash memory card digital recorder. This ultra-compact unit weighs less than 3 lbs., and is equipped with a built-in microphone and speakers. SD cards of up to 8GB capacities allow for over 12 hrs. of audio recording. The machine provides a backlit display and a handy Easy Guide button for simplified, immediate operation.

- Ultra-portable 2-channel digital CD and SD card recorder
- Built-in speakers and microphone
- Key, pitch and tempo playback adjustment for music study, practice
- Wireless remote control
- (2) RCA stereo line ins, (2) 1/4" stereo mic ins,
- 1/8" stereo line out, 1/8" stereo headphone out
- AC or "AA" battery-powered



## ALESIS CD TWIN LE

The CD Twin LE is a stand-alone CD duplicator that simplifies the process of making quick copies of music and media CD's. With a "One Touch" operation, you can back-up an entire CD. It also features a compilation mode that allows you to compile a custom CD using different tracks from several different CD's. A 2x16 LCD display aids in making these operations as easy as possible.

#ALCDTLE  
**\$179<sup>00</sup>**

- Archive music, data, photos, and CD+G discs
- Supports CD, Data CD, VCD, CD-1, CD+G, and Photo CD formats
- Uses both CD-R and CD-RW discs
- Stand-alone unit, no computer necessary
- 24x disc copying speed
- 3.88 lbs



## DENON DN-C550R

#DEDNC550R  
**\$699<sup>00</sup>**

Denon's DN-C550R is a professional rackmount dual-drive CD recorder and playback unit featuring selectable copying modes with defeatable SCMS and normal or 2x dubbing speeds. Adjustable analog and digital recording levels are available via the jog dial, and the unit supports both text input and display. The machine is equipped with 24-bit D/A converters and sounds great, too.

- Professional rackmount dual-drive CD-R/RW playback and dubbing deck
- 24-bit D/A converters, selectable 32/44.1/48kHz SRC
- Digital gain control and fade in/out
- (2) XLR balanced and (2) RCA phono unbalanced analog inputs
- (4) RCA analog outputs, 1/4" headphone output with volume control
- Coax and TosLink SPDIF digital I/O's

## MARANTZ CDR-632

#MACDR632  
**\$549<sup>00</sup>**

The CDR-632 is a rack mount single-well CD-RW recorder designed for the professional install market. This high-quality workhorse features programmable auto-track increment, pitch control, level dependent sync recording, single play mode, & power-on play. It is equipped w/analog, digital, and optical input and output and adjustable pitch control on playback.



- CD-R and CD-RW Recorder and Player
- Analog Coaxial S/PDIF and TosLink Inputs/Outputs
- Plays MP3's for hours of playback from one disc
- On-the-fly sample rate converter
- Auto-fade In/Out with programmable time
- CD-text and CD-text Input from front panel
- Continuous, Shuffle, Programmable, and Single playback modes



## TASCAM CD-RW900SL

#TACDRW900SL  
**\$599<sup>00</sup>**

The CD-DW900SL is a professional slot-loading rackmount CD-R/RW recording deck for studio and installation applications, featuring 24-bit converters, selectable SRC, analog and digital I/O's, a large, bright display, and MP3 playback. The sleek, intuitive front panel offers an easy-access control layout and CD-Text read/write capability.

- Professional slot-loading CD recording deck
- Records CD-R's and CD-RW's, plays back MP3's
- Stereo RCA Phono analog I/O's
- Coaxial SPDIF and TosLink optical digital I/O's
- PS/2 keyboard input
- 1/4" headphone output with volume control

## MICROBOARDS CopyWriter Live

The many features of the CopyWriter Live CD recorder make it the perfect unit for churches and schools as well as conference rooms and lecture halls. This 2U rack-mountable or tabletop unit not only features RCA, XLR, and microphone inputs but also allows you to duplicate up to 20x speed from a host of formats. For longer recordings the spanning feature allows seamless recording between discs as one becomes full.

#MICWL  
**\$699<sup>00</sup>**

- Two 20x CD-R/RW drives
- (2) sets of stereo RCA inputs and stereo XLR inputs
- Mic input
- Record and Pause to create multiple tracks for playback
- Create audio CD's playable in virtually any CD player



- Automatic format detection
- Rack mounting kit included

### TASCAM CD-160MKII

TACD160MK2  
**\$299<sup>00</sup>**

The CD-160MKII is an affordable rack mount CD player designed for studios and system installations. It features an Auto Cue function (cue to first audio in track not actual ID location), S/PDIF digital output, pitch control, and a front-panel number pad for accessing track numbers. Repeat, random and thirty-two-song program play modes are available as playback options.



- 2U rack mount CD player
- Unbalanced RCA analog output
- Auto Cue function (cue to first audio in track) S/PDIF digital output
- Front-panel number pad for track navigation
- $\pm 6\%$  pitch control with LED on/off switch
- Headphone output with level control
- RC-150C wireless remote included



### TASCAM CD-01U Pro

#TACD01UP  
**\$599<sup>00</sup>**

- 1U slot-loading CD Player
- (2) XLR & (2) RCA analog outputs
- AES/EBU & optical S/PDIF digital outputs
- Key Original mode
- Serial control via RS-232C

- $\pm 12.5\%$  pitch control
- Repeat, Single-Play and Program playback modes
- MP3, CD-R/RW playback, Including 12cm & 8cm CD's

**CD-01U unbalanced version w/o AES/EBU #TACD01U.....\$499.00**

The CD-01U is a professional rack mount CD player ideal for broadcast and installation applications. It features a RS-232 control port for programming w/AMX and Crestron systems, balanced XLR analog outputs, AES/EBU digital outputs and a 20-second RAM buffer f/shock protection. The reliable TASCAM slot-loading CD transports provides years of trouble-free use.

### TASCAM CD-601MKII

#TACD601MK2  
**\$1999<sup>00</sup>**

The CD-601MKII is a 3U half-rack size CD player designed for the professional broadcast market. Its comprehensive feature set includes: On-Line (on-air) and Monitor (pre-listen) playback modes, XLR balanced and RCA unbalanced outputs, Word Clock sync, pitch control, auto cue w/five threshold levels, Auto Read, & CD-text. The optional RC-601MKII remote control allows frame-accurate search using the jog wheel and direct location using numerical keys, index searches or flash starts.

- XLR Balanced and RCA unbalanced outputs
- AES/EBU and S/PDIF digital outputs
- Word Clock sync In and thru
- Sample Rate converter for 48kHz playback
- Plays CD-DA, CD-RW and CD-R media
- $\pm 12.5\%$  Pitch Control in 0.1% steps
- Selectable output



**Optional Wired remote control #TARC601MK2.....\$1199.00**



### DENON DN-C635

#DEDNC635  
**\$499<sup>00</sup>**

- Professional installation-grade CD player
- XLR Balanced and RCA unbalanced outputs
- Coaxial S/PDIF output
- Play mode and Finish mode
- Shock-Proof memory

- CD-R/RW playback compatibility & MP3 decoding
- Includes: RS-232, contact closure, and infrared remote control
- 2U rack-mount chassis

The DN-C635 is a high-end, rack mount CD player ideal for installation applications. Its professional features include: balanced XLR outputs, coaxial S/PDIF output, MP3 compatibility, CD-text and RS-232 control (AMX/Crestron compatible). A sliding fader allows users to adjust the play speed of CD's or MP3 discs by  $\pm 12.0$  percent (in increments of 0.1 percent).

### DENON DN-C615

#DEDNC615  
**\$299<sup>00</sup>**

The DN-C615 is an affordable single-tray CD player with a host of features normally found on much higher priced units. Ideal solution for schools, churches, small radio stations, and small venues, the DN-C615 provides CD-R/RW playback compatibility, CD-text, Auto cue, direct track select buttons, and pitch control. Outputs include stereo unbalanced RCA analog and coaxial S/PDIF digital.



- Low cost professional CD player
- Unbalanced stereo RCA outputs
- Coaxial S/PDIF output
- CD-R/RW/MP3 Playback compatibility
- Playback Mode: Single/Continuous (preset selectable)
- Instant start
- Pitch control  $\pm 12\%$
- 2U rack-mount chassis



**DENON**  
**DN-T645**

#DEDNT645  
**\$669<sup>00</sup>**

The DN-T645 is a combination CD/Cassette deck ideal for use in houses of worship, classrooms, and board rooms. This affordable dual-well unit provides IR & serial connectivity, RS-232 control, balanced I/O & cascade recording, and playback. The DN-T625s I/O includes: Tape/Mix-XLR and RCA input/output, CD-XLR and RCA output, two 1/4" mic inputs, coaxial S/PDIF digital output.



- (2) XLR analog inputs, (2) 1/4" front panel mic inputs
- XLR Balanced & RCA unbalanced outputs
- Coaxial S/PDIF output
- CD-R/RW Playback compatibility and MP3 Dolby B/C Noise Reduction decoding
- Direct track select buttons or rotary track select knob
- Repeat mode (single track/all tracks/A-B/random repeat) • Pitch control ±12%



#TACC222SL  
**\$799<sup>00</sup>**

**TASCAM**  
**CC-222SL**

The Tascam CC-222SL is a professional rackmount combo cassette and slot-loading CD recording deck for studio and installation applications, featuring 24-bit converters, analog and digital I/O's, and a large, bright display. The unit functions as two independent recorders, and is also records a single source to both sections simultaneously. The CD recorder supports CD-R/RW's and MP3 playback.

- Professional combo cassette and slot-loading CD recording deck
- Records CD-R's and CD-RW's, plays back MP3's
- Large display featuring timecode readout
- Independent or joint simultaneous recording
- Coaxial SPDIF and TOSLink optical digital I/O's
- Stereo RCA RIAA Phono turntable input
- RCA Analog I/O's, 1/4" headphone output

**DENON**  
**DN-T625**

#DEDNT625  
**\$499<sup>00</sup>**

The DN-T625 is a combo CD player and cassette player/recorder with an industrial build quality. It's capable of continuous relay playback between CD and cassette, as well as having individual repeat play functions. The CD player is compatible with CD-R / RW discs, and the pitch can be adjusted by 12%. Its professional analog and digital outputs will provide premium sound necessary in houses of worship, dance studios, and restaurants.



- 10 seconds of shock-proof memory to avoid CD skipping
- Compatible with CD-R/RW discs, displays CD-text
- Independent I/O and deck operation and continuous playback
- Headphone output and level control
- RCA and XLR I/O, 3U rack-mount



**TASCAM**  
**CD-A500**

#TACDA500  
**\$399<sup>00</sup>**

The CD-A500 is a CD player and tape recorder/player combination in one unit. It offers the ability to make cassette copies of entire CD's or individual tracks, and it can be set up for continuous playback from deck to deck. The pitch of the cassette deck can be adjusted by 12%, and a wireless remote control is included. Designed for ease of use with rugged construction, it's ideal for restaurants, offices, and fitness centers.

- Continuous play function between cassette and CD
- 12% pitch adjustment on cassette deck
- Wireless remote control included
- Reversible cassette deck, dedicated CD player outputs
- 3U rack-mount design

**TASCAM**  
**CD-A700**

#TACDA700  
**\$549<sup>00</sup>**

The CD-A700 is a CD player and tape recorder/player combo with professional features. It has separate outputs for CD and cassette; therefore each deck can be used independently or used together for continuous playback functionality. DJ's and dance instructors can utilize the 12% pitch adjustment on both the CD and cassette player. Professional XLR and digital outputs are included for optimum sound quality.



- Continuous play function between cassette and CD
- 12% pitch adjustment on both cassette and CD deck
- Wireless remote control included
- Balanced XLR, unbalanced RCA, and SPDIF digital outputs • 3U rack-mount design

**KURZWEIL****KSP8**#KUKSP8  
**\$2696<sup>00</sup>**

The Kurzweil KSP8 is a feature-laden professional 8-channel 24-bit/48kHz multi-effects processor capable of simultaneous EQ, Compression, and Effects in both stereo and surround modes. Provided with some of the best reverb algorithms available, this powerful audio shaping tool delivers soundscapes from the lush and natural, to the inspirationally evolving, making it a perfect choice for both mobile and studio stereo and surround music tracking, film, and video game sound design, and final post production applications.



- 249 DSP algorithms with over 600 preset programs
- Ultra-dynamic patented signal path with superior audio conversion
- Highly flexible internal submixing
- Unmatched real-time control
- (4) Balanced 1/4" TRS I/O and stereo AES/EBU I/O

**KSP8 optional remote control #KURSP8 ..... \$535.00****EVENTIDE****DSP4000B+**#EVDSP4000B  
**\$3495<sup>00</sup>**

- Six-line graphic LCD fast program access and easy editing
- High-quality Timesqueeze stereo time compression and expansion
- Digital I/O for a full 24-bit AES/EBU and S/PDIF signal path
- (2) XLR input, (2) XLR output, MIDI in, out and thru
- Patch editor function lets users build totally new effects algorithms

The DSP4000B+ is an application-specific audio effects processor with a unique set of software programs created especially for radio, TV, and post-production. Effects groupings such as "Science Fiction Voices," "Commerce & Machines," and "Backgrounds" (such as jet fly-bys, rain and thunder, and the seashore), are already set up and ready for instant recall, making it a terrific time saver in program, commercial, and post-production.

**EVENTIDE****ECLIPSE**#EVECLIPSE3  
**\$1995<sup>00</sup>**

The Eventide ECLIPSE is a dual-engine professional 24-bit/96kHz Harmonizer and multi-effects processor designed for the high-end studios in need of extensive processing power. Its superb fidelity, combined with extensive routing and editing capabilities, make it ideal for easily interfacing a powerful multi-effects processor into a digital production studio. With the ECLIPSE, sound design, production, and recording engineers finally have all the tools they need without sacrificing precious DSP.



- 400 Presets and 100 User programs
- Eventide's signature Pitch change, Reverb and Harmonizing algorithms
- Pristine audio path with 24-bit/96kHz resolution
- Balanced XLR/TRS I/O
- Digital formats and I/O includes AES/EBU, S/PDIF and ADAT (Optical)
- 110dB dynamic range (output)

**T.C. ELECTRONICS****FireworX**#TCFIREWORXQ  
**\$1499<sup>00</sup>**

- Excels in the creation of unconventional and indescribable effects
- (2) XLR analog inputs (2) XLR analog outputs
- ADAT, S/PDIF and AES/EBU with word clock
- 8 internal modifiers including envelopes, ADSR's and LFO's
- 400 factory preset and 200 user-bank memory locations

The FireworX is a radical-sounding, multi-effects processor that delivers reverbs, delays, flangers, and the like flawlessly, and then veers into the realm of vocoders, resonance filters, chaos generator synths, ring modulators, and much more. As you place effect algorithms on its 8x8 routing grid they are automatically "wired" together in parallel or serial until you hit the DSP power limit without affecting effects quality.

**YAMAHA****SPX2000**

Ideal for a wide variety of audio applications, the SPX2000 is Yamaha's next generation of high-performance effects processor. Its advanced Rev X reverb algorithm, 24-bit/96kHz audio path, and powerful DSP provide users with over 200 outstanding multi-effects.



- 122 Presets and 99 User programs
- SPX2000 Editor for Mac OSX and Windows
- 24-bit A/D conversion
- BNC Word Clock connector
- Unique 5-Color LCD for easy recognition of effects types
- AES/EBU Digital I/O
- Balanced XLR/TRS 1/4" I/O

#YASPX2000  
**\$999<sup>00</sup>**

**LEXICON**  
**MPX 1**

#LEMPX1  
**\$699<sup>00</sup>**

Utilizing dedicated LexiChip technology, the Lexicon MPX 1 is a high-quality, dual-engine, multi-effects processor with uncompromising stereo reverbs and stunning effects. Its simple user interface and vast array of intuitive controls provide users with all the necessary tools for producing lush, creative soundscapes.



- 200 Presets and 50 User programs
- 24-bit A/D-D/A 44.1kHz conversion
- 56 Effect algorithms
- Discrete Dual Mono or Stereo processing
- Balanced XLR and TS-1/4" I/O
- Midi In/Out/Thru



**LEXICON**  
**MX400**

#LEMX400  
**\$399<sup>95</sup>**

- (4) 1/4" phone analog inputs and outputs for true quad processing
- Includes 25 factory and 25 user surround programs
- USB connection with VST and Audio Units plug-in software
- Large front panel LCD display with (3) quick access editing knobs

The MX400 packs extreme versatility into a small package with the ability to not only provide clean, smooth-sounding reverbs and delays, but also to lighten the processing load on your computer recording system. By appearing as a software plug-in inside any VST or AU compatible DAW program, you can easily access and edit all of its programs and parameters with the connection of only a single USB cable.

**MX400XL** adds XLR inputs and outputs #LEMX400XL ..... **\$449.95**

**T.C. ELECTRONIC**  
**M-One XL**

Ideally suited for live sound, the T.C. Electronic M-One XL is a dual-engine effects processor with improved algorithms and flexible routing capabilities, giving engineers high-quality multi-effects at an affordable price.



- 200 Presets and 100 User programs
- 24-bit A/D conversion
- Serial/Parallel routing configuration capability
- SPDIF Digital I/O
- Balanced XLR I/O
- Midi In/Out/Thru

#TCM1XL  
**\$399<sup>00</sup>**



**LEXICON**  
**MX-200**

#LEMX200  
**\$199<sup>95</sup>**

- 99-effect presets/99 user
- 16 legendary Lexicon reverbs
- USB "Hardware Plug-in" feature
- dbx Dynamics
- VST and Audio Units software/MX-Edit Editor/Librarian software
- (2) 1/4" TRS balanced or unbalanced outputs
- S/PDIF digital I/O

The Lexicon MX-200 combines 32 legendary Lexicon effects into a single-space unit for two completely unique applications; live sound and computer integrated studio recording. Easily integrate your favorite recording software with the MX-200, essentially turning it into a plug-in, freeing up precious DSP, or take immediate control of effects, dynamics, and their parameters utilizing an intuitive front panel with single push button functionality.

**T.C. ELECTRONIC**  
**M350**

#TCM350  
**\$199<sup>00</sup>**

The M350 is a dual-engine reverb and multi-effects processor suitable for both live and studio applications. The two engines may be used serially or in parallel mode, and the easy-access front panel controls allow for convenient, intuitive control. The high-density 24-bit converters and processing ensure an expensive sound from a refreshingly affordable unit.



- Dual-engine effects processor for stage or studio use
- Clearly-labeled front panel with easy-access control knobs
- 24-bit converters
- 15 reverbs and 15 multi-effects, 256 presets, up to 5-sec. delay time
- Pedal-controlled Tap tempo, MIDI Clock tempo sync
- 1/4" TRS Analog I/O's
- Coaxial SPDIF digital I/O's



**KORG****KP3 KAOSS Pad**

The KP-3 KAOSS Pad is a unique tabletop effects processor for modern laptop DJ's and musicians, featuring an X/Y touchpad allowing for real-time control of multiple effects parameters. The unit's loaded with programs ranging from delays and filters to esoteric vocoder and grain shifter sounds. The KP-3 is also an innovative sampling device with dedicated Sample Bank access.

- Tabletop multi-effects processor with X/Y touchpad control
- 128 programs include delay, flanging, vocoding and synthesizer sounds
- Real-time BPM control of modulation effects
- Loop and one-shot sampling from external source, internal re-sampling
- Stereo RCA Phono line and 1/4" TS microphone inputs, headphone out
- USB computer connection, stereo RCA outputs

#KOKP3  
**\$399<sup>00</sup>**

**ZOOM**  
**RFX-2200**

#ZORFX2200  
**\$199<sup>00</sup>**

The RFX-2200 multi-effects processor features 44.1kHz, 24-bit signal processing for great sound quality, 121 types of preset reverb settings and 48 types of multi-effects patches. It also features 100 storable user presets, a tap-tempo function, S/PDIF and optical digital outputs, as well as full MIDI control with MIDI in, out and thru connections.

- Front panel XLR combination jack for direct signal processing
- SP/DIF digital out and mix-down effects for final mastering
- Lo-fi, resonance, and ring modulator effects for remix and DJ applications
- 121 preset reverb characters, 48 multi-effects and 100 user presets
- MIDI in allows program change and parameter control

**BEHRINGER****Minifex FEX800**

The FEX800 is an inexpensive stereo effects device that features powerful 24-bit 48kHz audio quality and useful controls. A rotary knob and LED display take you through its 16 presets of reverb, delay, chorus, flanger, phaser, rotary speaker, pitch shifter and multi-effects. A tap/select button allows you to sync or edit the chosen effect. Illuminated buttons and a six segment input meter keep you in control.



#BEFEX800  
**\$49<sup>99</sup>**

- Unbalanced 1/4" inputs, balanced 1/4" TRS outputs
- Port on rear allows unit to be engaged hands-free with optional footswitch
- Input level, output level, and dry/wet knobs on front panel
- Designed to stack on top of other Behringer Mini Series units
- 24-bit converters, 48 kHz sampling rate

**ALESIS**  
**MidiVerb4**

#ALMD4  
**\$199<sup>00</sup>**

- 32 effects algorithms with up to three simultaneous multi-effects
- 256 powerful programs with 128 spaces for user-created effects
- (2) 1/4" analog inputs with Auto Level Sensing, (2) 1/4" analog outputs
- Even offers true stereo high fidelity parallel processing
- MIDI in, out/thru with internal controller routing

With its large, easy-to-use graphic interface and automatic input level-sensing circuitry, the MidiVerb4 can get you up and running with just the effects you need with surprising ease. The MidiVerb 4 offers 18-bit A/D-D/A converters and 24-bit internal processing for a 20Hz-20kHz bandwidth and 90dB dynamic range, making it ideal for enhancing both your digital recordings and live performances.

**ALESIS****Microverb4**

#ALM4  
**\$149<sup>00</sup>**

The key to MicroVerb 4's power is in its simplicity. It offers 200 programs that include everything from high-quality reverb, delay, chorus, and flange to exciting multi-effects and more. And despite its seemingly uncomplicated interface, important functions like input, mix, and output levels have their own front panel controls along with two editable parameters per preset.



- Four-segment dual LED input meters and three digit display
- A wide variety of great-sounding, easy-to-use effects
- Great for studios, engineers, and performing musicians
- Program changes and modulations may be MIDI controlled
- (2) 1/4" analog inputs, (2) 1/4" analog outputs and (1) 1/4" foot-switch input

### KORG mini-KP

The Mini-KP is the smallest and most portable addition to the popular Kaoss Pad series of effect processors. Its fingertip-controlled touchpad allows the user to tweak real-time effects and play the Mini-KP like an instrument. 100 musical effects are onboard including filters, delays, loopers, and reverbs. With battery power, it fits in your pocket so you can bring this Kaoss Pad anywhere.

- Tap/BPM button allows user to synchronize effects to music
- Intelligent pad recognizes when fingers release and adds effect
- Optional AC adapter available
- Different effect parameters controlled in the X- and Y- pad axis
- Hold button to freeze selected effect
- (2) Memory keys to store effect program settings

#KOMINIKP  
**\$199<sup>00</sup>**



### BEHRINGER Virtualizer Pro DSP 2024P

#BEDSP2024P  
**\$99<sup>99</sup>**

The Pro DSP 2024P features 71 brand-new, impressive effect algorithms, giving you powerful modulation, virtual room-reverb algorithms, amp simulations, distortions and special effects as well as effective dynamic and psychoacoustics processing and equalization. The DSP2024P allows you to edit up to 7 parameters per preset, giving you extra power to customize your effect settings.

- (2) XLR and 1/4" analog inputs, (2) XLR and 1/4" analog outputs
- Sampler, ring modulator, lo-fi, and vocoder programs
- 11 effect combinations with selectable serial/parallel options
- Each preset offers an additional high and low eq section
- Internal power supply keeps your rack clean and uncluttered

### ALESIS PicoVerb

The PicoVerb is a no frills, very affordable digital multi-effects unit that puts 16 must-have effects into a 1/4 rack space housing that easily fits into your gig bag or next to your mixer. Choosing an effect for your application just could not be easier; just set your input and mix levels with any of the preset reverb, delay or modulation programs, and you are ready to go.

#ALPV  
**\$79<sup>00</sup>**

- Extremely compact size for ultra-portability
- 28-bit internal processing, 48kHz sample rate
- Perfect for studio and sound reinforcement applications



- Stereo 24-bit 1/4" connections with input level control
- 16 presets including halls, rooms, plates and more



### BEHRINGER Shark DSP110

#BEDSP110  
**\$79<sup>99</sup>**

The Shark DSP110 combines an ultra low-noise mic/line preamp with a variety of useful signal processing options, including feedback elimination, time-alignment delay, compression, and noise gating. Switchable 48V phantom power, 24-bit A/D-D/A conversion and balanced connections make this small box the perfect live sound problem solver.

- Automatic feedback destroyer circuitry with learn function
- 2.5 seconds of delay available, adjustable in meters, feet and msec.
- Level conversion from line to mic level and vice versa
- Subsonic filter with adjustable cutoff frequency
- Noise gate with automatic and manual parameter adjustments
- Up to five units can be rack mounted in just over one space

### ALESIS Nanoverb

The Alesis Nanoverb is a conveniently straightforward 18-bit digital effects processor. Simply choose the effect you want, adjust its amount, then dial in its input, mix and output levels accordingly. An ideal pocket processor for adding depth and color to small live performances or presentations.

#ALNV  
**\$99<sup>00</sup>**



- 16 preset programs
- Great sounding 18-bit digital effects
- Unbalanced 1/4" TS connectors
- Fully adjustable input and output levels
- Compact design allows mounting capability of up to three units in a single rack space

### T.C. ELECTRONIC

## Reverb 4000

#TCR4000  
\$2499<sup>00</sup>

The Reverb 4000 is a professional true stereo main reverb unit that features an extremely easy-to-use instant access interface, a wide selection of simulated rooms and spaces, as well as impressive headroom and level handling. It integrates perfectly with digital audio workstations with 24-bit AD/DA converters, 44.1-96kHz sample rates, and computer editing with included ICON software.



- Digital and analog wide dynamic range design
- 24-bit AES/EBU, Tos-Link, S/PDIF, ADAT and Analog I/O's
- Realistic environments, from a closet to a canyon
- Connectable via USB to access included ICON software editor
- Instant access interface make it ideal for studio or live venue use



### EVENTIDE

## Reverb 2016

#EVR2016  
\$1995<sup>00</sup>

The 2016 recreates the legendary reverbs from Eventide's SP2016, which was developed as a leading-edge dedicated studio spatial processor. Like the original, the redesigned interface is streamlined and extremely easy to navigate but, unlike the original, it offers two channels of 24-bit I/O and contains three new algorithms that provide updated variations on each of the original reverbs.

- 6 high-quality reverb effects in a solid single rack space unit
- Fast user interface dedicates one knob per function
- Front panel input kill and relay bypass switches
- 24-bit conversion with S/PDIF digital I/O
- Universal internal power supply works anywhere

### LEXICON

## PCM 81

#LEPCM81  
\$1999<sup>00</sup>

The PCM 81 is a high-powered effects processor that features two digital signal processors: Lexicon's proprietary Lexichip, to run the reverbs, and a second DSP engine to handle effects like quadruple-tracking, chorus, and extremely smooth sounding delays. This allows the unit to dedicate serious horsepower to both reverb and effects algorithms without sacrificing the quality of either. It boasts 24-bit internal processing, a true stereo signal path, balanced analog I/O, full AES/EBU and S/PDIF digital I/O, the ability to mix analog and digital inputs together, plus extensive modulation capabilities, making it the perfect unit to free up processing in your hard-disk recording setup.



- Studio standard Lexicon reverbs and effects
- (2) XLR & (2) 1/4" TRS inputs and outputs
- Single Adjust knob designed for fast effect customizing
- Pro and Go modes streamline the editing process
- Dynamic spatialization effects for 2-channel or surround applications



### T.C. ELECTRONIC

## D-Two

#TCD2  
\$499<sup>00</sup>

The D-Two is a great-sounding dedicated digital delay unit that actually lets you create your own rhythmic delay patterns to exactly match your effects to your music. With an inviting price and single rack space design, this unit boasts an impressive library of delay-based effects, from choruses and ping-pongs to spatial expanders, that add extra width to the sound of your material.

- (2) 1/4" balanced analog phone inputs and outputs
- S/PDIF digital I/O with MIDI in, out and thru
- Actual rhythm patterns can be tapped-in directly or quantized
- Delay signal may be reduced or increased proportionate to input level
- Onboard filter for creating softer, more natural delay effects

### BEHRINGER

## V-Verb Pro Rev2496

#BEREV2496  
\$999<sup>99</sup>

The Pro Rev2496 digital reverb unit draws its strength from two independent effects processors that can be accessed via both analog and digital connectors, making it a flexible addition to your setup. It also features 8 high-end reverb algorithms modeled after world-class reverb processors plus additional high-quality modulation effects, from delays to flangers, plus stereo compression.



- Reverb modeling with high-quality 24-bit/96kHz A/D and D/A converters
- Separate ROM and user preset banks with 400 presets total
- Balanced inputs and outputs with gold-plated XLR and 1/4" TRS connectors
- Soft push/turn encoders with high-resolution graphic LCD display
- Full 4-channel operation with up to 96kHz without any limitations



### T.C. ELECTRONIC INTONATOR

#TCI  
**\$699<sup>00</sup>**



For the professional studio in search of the ultimate vocal processor, the TC Electronics INTONATOR is a high-end processor that effectively preserves vocal subtleties with individual intonation and correction, isolating even a single note. Its high 24-bit/96kHz resolution provides a transparent digital signal path, flexible signal routing, and simultaneous pitch and dynamics corrections on separate channels, effectively saving time and money while eliminating the need to cut and paste.

- Real-time pitch correction with user-definable pitch adjustment thresholds
- High-quality converters allow additional gain to be added before or after digital conversion
- Digital dithering reduces output distortion
- Adaptive LoCut dynamically controls filter cut off frequencies according to input signal
- Word Clock Sync
- Digital formats and I/O includes AES/EBU (XLR), S/PDIF (RCA), TOS-Link and ADAT (Optical)
- Balanced XLR analog I/O



### T.C. HELICON VoiceLive

#TCVL  
**\$799<sup>00</sup>**

The VoiceLive puts a rack's worth of studio quality vocal sweetening equipment right at your feet for use live on stage. Customize a signal path with EQ, Compression, Pitch Correction, Vocal Thickening, Natural 4-part Harmony, Delay, and Reverb. Save presets and scroll through them song by song, or even turn on and off harmonies and effects during a song.

- Integrated limiter protects signal from clipping
- Studio-quality preamp with phantom power
- Mic-thru output for FOH monitor mix
- Dedicated instrument input to mix vocals + instrument
- Transparent pitch correction/4 voice harmony
- Assignable switch for tap tempo/harmony hold

### DIGITECH Vocal 300

#DIV300  
**\$199<sup>95</sup>**

The Vocal 300 was designed to give singers and vocal artists the ability to take control of their sound with hands-free operation on stage, in the studio, or at practice. Preset changes, bypass, and live tweaking with the expression pedal are all controlled with your feet. Combine up to seven simultaneous effects with staples like Reverb, Compression, and EQ, or get freaky with Whammy, Strobe, and the Pixelator.

- 24-bit A/D converters
- 1/4" TS input and XLR input and output
- 40 Factory presets, 40 user-definable presets
- Chorus, Phaser, Tremolo, Doubler, Pitch Shifter, Ping Pong Delay, and more
- Headphone output for practicing
- 1/8" line input to connect a CD or MP3 player



### T.C. ELECTRONIC VoicePro

#TCVP  
**\$2999<sup>00</sup>**

The VoicePro is a powerful vocal modeling processor that not only creates smooth accurate four part harmonies but also can change the very character of each, surrounding your lead vocal in lush harmonies or helping you work up convincing group arrangements on your own. The application-based user interface logically guides you through the process of getting the sound you want with a large color display and well laid out set of controls.

- (2) XLR analog inputs, (2) XLR analog outputs, (8) AES/EBU out
- 24-bit AD/DA conversion with up to a 96kHz sampling rate
- Vocal toolbox featuring modeling, harmonization, and pitch correction
- Onboard high-quality reverbs, tap tempo delays, distortions, and more
- Special transducer feature for emulating telephones, radios, and megaphones

### T.C. ELECTRONIC VoiceWorks

#TCVW  
**\$599<sup>00</sup>**



With its built-in, phantom supplied, quality mic preamp and full range of DSP, the VoiceWorks is the ideal studio or stage tool for dialing in great sounding vocals. Fatten up your sound with two layers of voice thickening, add stunning four part harmonies or apply compression, eq and pitch correction for a finishing touch.

- 4 independent harmony voices, 4 distinct harmony modes
- HarmonyHold lets you freeze backing vocals and continue singing
- Scale-based pitch correction for studio and live performance
- (1) XLR and (1) 1/4" balanced analog input, (2) 1/4" balanced analog outputs
- S/PDIF I/O with MIDI in, out and thru jacks

## FOCUSRITE Red 3

#FOR3  
**\$4699<sup>99</sup>**



The Red 3 is a dual compressor/limiter that uses a high-quality audio VCA that serves as the only element between input and output, keeping the signal path short for a very natural and unobtrusive sound. Each channel features well laid out controls for compression ratio, threshold, make-up gain, attack, release, and limiter threshold. A program-dependent auto-release mode is available, and the VU meters can be switched to show levels in two ranges, or amount of gain change. The side-chain electronics are Class A, ensuring superb transient response.

- (2) XLR inputs, (2) XLR outputs and (2) XLR key inputs
- Stereo switch for true stereo operation from a single set of control
- Key inputs with illuminated push-button selection
- Precision VU metering of signal level or gain change



## UNIVERSAL AUDIO LA-2A

#UNLA2AL  
**\$2999<sup>00</sup>**

The LA-2A is a hand-built rebirth of the legendary Teletronix LA-2A leveling amplifier, prized for its natural compression characteristics. A unique electro-optical attenuator system allows instantaneous gain reduction with no increase in harmonic distortion — an accomplishment at the time, still appreciated today. Each unit is hand built and each component is carefully evaluated for authenticity. No expense has been spared to guarantee that this LA-2A will bring that classic sound to your recordings.

- (1) XLR and Jones Barrier input, (1) XLR and Jones Barrier output
- True to the original in design, manufacturing and performance
- Lag-free, distortion-free optical attenuator system
- 0 to 40 dB gain limiting with less than 0.5% THD

## UNIVERSAL AUDIO LA-3A

#UNLA3A  
**\$1699<sup>00</sup>**

After its introduction in 1969 the LA-3A was immediately embraced as a studio workhorse and is still widely used today. This single-channel unit remains a favorite of engineers and producers worldwide for its unique compression characteristics and sonic signature. This reissue of the LA-3A meticulously retains all the internal and external qualities of the original, down to the same simple control set and T4 electro-optical attenuator, which is the source of the LA-3A's program-dependent compression. All the original rear panel connections and controls are also maintained, while the commonly-performed "LA-3A gain mod" is added as an additional switch for maximum studio versatility.

- Single-channel Classic Solid State Opto-Compressor
- XLR and Jones Barrier connections
- Discrete Amplifier — up to 50 dB gain
- Rear Panel "Gain Mod" switch for gain control
- Includes single unit rack mounting kit



## UNIVERSAL AUDIO 1176LN

#UN1176LNL  
**\$1999<sup>00</sup>**

The original Universal Audio 1176LN was a major breakthrough in limiter technology — the first true peak limiter with all transistor circuitry offering superior performance and a signature sound. While it certainly would have been much simpler to modernize and "improve" the 1176LN, every effort was made to remain faithful to its original design. This Universal Audio Classic version of the 1176LN captures all the nuance of the original through obsessive attention to detail, and delivers that trademark sound.

- Single channel classic limiting amplifier
- XLR and Jones Barrier connections
- Ultra fast 20 to 800 microseconds attack time
- True to original in design, manufacturing and performance
- Class A line level output amplifier

**1176SA** calibrates two mono 1176s for stereo operation # UN1176SA... **\$99.00**

## AVALON VT747SP

#AVVT747SP  
**\$2450<sup>00</sup>**

The VT747sp is a Class-A, vacuum tube-discrete twin signal path Opto-compressor with a musical six-band program equalizer, and output level and gain-reduction metering. This incredible-sounding, 100% discrete processor is ideal for high-performance DAW input signal conditioning, stereo bus compression/EQ, and analog mastering applications.



- Balanced XLR I/O
- Twin Signal Path — allows choice of either tube tone or classic discrete transistor sound
- 6-band discrete passive program EQ
- Spectral side-chain monitor for pre-listen
- EQ Pre/Post selection for compressor
- Internal regulated power supply

## TC ELECTRONICS FINALIZER 96K

The TC FINALIZER is a professional two-channel 24-bit/96kHz mastering device that combines multi-band frequency dynamics control with a transparent signal path and flexible sample rate conversion. Its powerful features and ease of use give engineers all the tools required for creating crisper, punchier mixes with that "radio-ready" sound.



- Spectral balancing and normalization of multiple frequency bands
- Look Ahead Delay allows for faster, more accurate dynamic response
- ADAT bounce allows for simultaneous processing and recording of ADAT tracks
- Digital conversions between AES/EBU, S/PDIF and Toslink formats
- Balanced XLR analog I/O
- AES/EBU, S/PDIF, and TOS-Link/ADAT digital I/O
- 24-bit/96kHz A/D-D/A
- Sample rates include 32, 44.1, 48, 88.2 and 96kHz

#TCF96K  
**\$2499<sup>00</sup>**



- Format conversion: analog-to-digital, digital-to-analog, and digital re-quantization
- 24-bit/96kHz resolution w/48-bit end-to-end internal processing path
- Supports: optical, coaxial SPDIF, AES/EBU, balanced/unbalanced line level analog signals
- Precision metering with resettable peak hold options

## WAVES MaxxBCL

The MaxxBCL combines the famous L2-Ultramaximizer, the Renaissance Compressor, and MaxxBass into a rugged new hardware box. This 24-bit/96kHz processor combines the highest quality converters with unequalled processing algorithms to offer you astonishing new power in bass enhancement, dynamics processing, and format conversion. The MaxxBCL is ideal for live sound, mastering/post, and broadcast applications.

#WAMAXXBCL  
**\$2400<sup>00</sup>**

## DBX QUANTUM II

The DBX Quantum II is a versatile 24-bit/96kHz Multi-Band Processing Device that utilizes patented DBX technology to produce dynamic, polished mixes with noticeable warmth and depth. Featuring a wide dynamic range and extended headroom, the Quantum II applies Compression, Limiting, Gating, and EQ while maintaining the pristine audio quality needed for today's digital world of music production and mastering.

#DBQ2  
**\$2199<sup>95</sup>**



- 4-band multiple dynamics control
- Patented Type IV A/D conversion with Tape Saturation Emulation (TSE)
- Versatile MIDI control and internal/external sync capabilities
- Balanced XLR/TRS analog I/O
- GUI control and system upgrades available via PC
- AES/EBU and S/PDIF digital I/O
- 115 dB dynamic range
- 24-bit/96kHz A/D-D/As, with true 48-bit signal path



- Provides leveling, compression, and peak limiting
- (2) XLR inputs and (2) XLR outputs
- Virtually invisible compression characteristics
- User-defeatable peak limiting for effective system protection
- Fast, simple setup with no readjustment

**320D** same as above with AES/EBU digital I/O #AP320D **\$1299.00**  
**323A** single channel Compellor with Aural Exciter #AP323A **\$849.00**

## APHEX 320A Compellor

The 320A delivers intelligent compressor action, leveling, and peak limiting simultaneously. This intelligent, versatile, and highly affordable processor can be used to solve audio level problems and improve audio signals in the broadcast studio, recording studio, tape duplication house, film dubbing studio, and in live sound applications. Patented control circuits include analog computers that continuously analyze the input signal and vary the control characteristics to provide for virtually undetectable operation, regardless of the dynamics of the program.

#AP320A  
**\$1199<sup>00</sup>**

## MACKIE Quad Comp/Gate

The Quad Comp/Gate is a state-of-the-art four-channel rack mount digital compressor/gate designed to even be used in the demanding environment of live sound where speed and dependability are a must. Its compression/limiting and gating/expansion algorithms were written by the digital gurus at Acuma Labs to provide a very wide range of high-quality, instantly usable settings. The front panel is intuitively laid out with ultra-bright, 12-segment metering, multi-color backlit buttons, and nine backlit push-button knobs with LED collars to indicate settings from a mile away.

#MAQCG  
**\$879<sup>95</sup>**



- 4 channel digital compressor/gate
- (4) XLR & 1/4" TRS inputs and (4) XLR & 1/4" TRS outputs
- Side Chain input for triggering from external signals
- Auto feature adjusts attack and release times eliminating "pumping"
- 99 user-definable snapshots for instant recall
- Channels can be independent or stereo-linked with a single button press



## FOCUSRITE ComPounder

The ComPounder is a combined Dual Compressor/Limiter and Noise Gate/Expander. Each channel can operate independently on two mono signals, or both sections may be linked to operate on a stereo source. The limiter features a Class A low-distortion design and accurate threshold control, while the expander ensures professional noise reduction on difficult audio tracks such as vocals. A combination of high-quality compression with the powerful Bass Expander makes this unit a must-have for any dance music engineer, musician, or club installer.

#FOCD  
**\$599<sup>99</sup>**



- Dual channel compressor/limiter and noise gate/expander
- (1) XLR & 1/4" input and (1) XLR & 1/4" output
- Class A custom VCA compressor design
- Super-quiet Optical Gate/Expander circuit
- High-performance optical limiter
- Full stereo linking capability



- High-end, single-channel tube leveling amplifier
- Flattering tone that adds musical warmth and precise control of signals
- Compact half-rack design ideal for smaller studios or mobile rigs
- 3-position attack and release settings
- Balanced XLR (+4dB) and unbalanced 1/4" (-10dB) I/O

## SUMMIT AUDIO TLA-50

#SUTLA50  
**\$629<sup>00</sup>**

The TLA-50 is a full-featured Tube Leveling Amplifier that adds classic warmth to your audio signal, while providing sweet, musical compression and control. It offers three-position attack and release switches, a continuously variable gain and gain reduction control, and precise VU metering of output and gain reduction.

## ASHLY CLX-52

#ASCLX52  
**\$300<sup>00</sup>**

The Ashly CLX52 is a high-quality dual-channel compressor/limiter. Popular among engineers for its unique "infinite soft-knee" function and extremely low-noise circuitry, the CLX-52 is perfect for a wide variety of high-end audio applications.



- Ratio, Threshold, Attack, Decay, and Output controls
- Stereo tie switch
- Great for speaker system protection
- Low-noise VCA circuit
- Detector (Ducking) insert patch point
- Balanced XLR and 1/4" I/O



## DBX 1046

#DB1046  
**\$499<sup>95</sup>**

The dbx 1046 is a high-quality 4-channel compressor/limiter known for its smooth dynamic processing, low-noise circuitry, and that "classic" dbx sound, making it a favorite among today's professional PA and sound reinforcement engineers.

- Four independent channels — linkable to true stereo pairs
- Switchable OverEasy or Hard-Knee compression
- PeakStopPlus Limiting
- Switchable operating level (+4dBu/-10dBV)
- Balanced XLR and 1/4" I/O

## PRESONUS ACP88

#PRACP88  
**\$899<sup>95</sup>**

The Presonus ACP88 is an impressive 8-channel compressor/limiter/noise gate that provides pristine musical-sounding dynamics processing. Designed with ultra-quiet circuitry, full-featured responsive controls, and a wide variety of spectral processing, the versatile ACP88 is an indispensable live sound and studio recording dynamics processor.



- (8) discrete channels of dynamics processing
- Side chain and trigger inputs on every channel
- Comprehensive linking via unique power summing bus
- Low noise, high headroom
- Switchable power transformer
- Balanced/unbalanced 1/4" TRS I/O's

**ART**  
**PRO VLA**

#ARPROVLA  
**\$299<sup>00</sup>**

The PRO VLA comes in a 2U rack-mountable chassis housing two independent channels of analog leveling/compression designed to work seamlessly with any recording, sound-reinforcement, or electronic instrument setup. Using a transformerless design throughout, it maintains exceptional signal integrity and extremely low noise. Its VCA-less design utilizes optical electronics (Vactrol) coupled with a 12AX7 vacuum tube gain stage for superior musical performance. This great-sounding box has stood up to many years on the music market and is extremely easy to operate.



- Two channel tube compressor/limiter
- (2) XLR & 1/4" inputs and (2) XLR & 1/4" outputs
- VCA-less design provides smooth musical performance
- Large backlit VU meters
- Ten-segment gain reduction LED array



**JOEMEEK**  
**MC2**

#JOMC2  
**\$229<sup>99</sup>**

The Mc2 is a professional studio-quality stereo compressor in a compact half-rack format. Simple to use yet extremely powerful, the Mc2 will bring out the best in any line-level stereo material and give the gloss of a professional studio to all your performances. This unit can be used for recording, mastering, or live work, and its small footprint allows it to fit into tight workspaces or rack shelves. It will also function as a stereo width processor and line level stereo preamplifier.

- Half-rack unit sized stereo compressor
- (2) 1/4" TRS inputs and (2) 1/4" TRS outputs
- Insert jack for accessing the units control sidechain
- Stereo width control sweeps from mono to extra-wide
- Gain Reduction Hold keeps noise floor constant between tracks

**BEHRINGER**  
**Multicom Pro-XL MDX4600**

The Behringer Multicom Pro-XL MDX4600 is a flexible, 4-channel compressor/limiter/expander/noise gate. Its improved "interactive" signal processing, ease of use, and ultra-low noise circuitry make the MDX4600 well-suited for live sound reinforcement and PA applications.



#BEMDX4600  
**\$129<sup>99</sup>**

- IKA (Interactive Knee Adaptation) Program-Adaptive Compression
- IRC (Interactive Ratio Control) Expander/Gate Circuitry
- IGC (Interactive Gain Control) Peak Limiting
- Stereo couple function for channels 1/2 and 3/4
- Switchable operating level (+4dBu/-10dBV)
- Servo-balanced 1/4" TRS/XLR I/O



**ALESIS**  
**3630**

#AL3630  
**\$99<sup>00</sup>**

- Ratio, Threshold, Attack, Decay, and output controls
- Hard and Soft Knee Compression response curves
- Stereo/Dual Mono Mode Link Switch
- Two fully independent Noise Gates
- Dual-channel compressor/limiter
- (2) 1/4" TS phone inputs and (2) 1/4" TS phone outputs
- Sidechain for keying or ducking effects
- Features stereo linkable operation
- Easy to read 12-segment LED metering

The 3630 provides two independent full-featured compressor/ limiters in one rack space while offering excellent sonic quality for any application from studio recording to live sound or broadcast. You can also choose between RMS and Peak compression styles, plus Hard and Soft Knee dynamic curves for every application from subtle gain control to in-your-face punch. As an independent dual-channel compressor, the 3630 offers separate controls for two different source signals with gating to easily and efficiently stifle unwanted ambient noise.

**PRESONUS**  
**COMP16**

#PRC16  
**\$99<sup>95</sup>**

Based on the award-winning BlueMax compressor design, the COMP16 is the simplest professional quality compressor in the world. Sixteen presets have been carefully tailored for a wide range of applications including vocals, percussion, fretted instruments, keyboards, stereo program material, and compression effects. Simply select the preset and adjust the input and output to desired level of compression. This is truly a great-sounding compressor that anyone can use.



- Easy-to-use single channel compressor
- (1) XLR & 1/4" input and (1) XLR & 1/4" output
- 16 presets cover a wide variety of applications
- Back-lit VU for metering compression
- Great for guitars and basses



### AVALON AD2055

#AVAD2055  
**\$3960<sup>00</sup>**

The AD2055 is a dual mono parametric equalizer that combines 100% discrete, pure Class A signal amplifiers with state-of-the-art passive and active filtering. The passive high and low bands offer alternate musical tone range to the full function active parametric mid bands. Avalon's advanced true symmetry design offers high-voltage, large headroom, extended bandwidth and very low noise. The AD2055 is the perfect solution for two-buss, music-program equalization, special instrument EQ and FX applications, and ultra-high performance mastering studios.



- Dual mono, pure Class A parametric music equalizer
- (2) XLR inputs and (2) XLR outputs
- Smooth musical detail and sonic excellence
- Minimum audio signal path
- Rugged hardware designed to last



### AVALON AD2077

#AVAD2077  
**\$12000<sup>00</sup>**

The AD2077 is a dual mono, pure Class A mastering EQ that features a DC coupled minimalist signal path. The combination of active and passive filter technologies offer the professional mastering engineer alternate tone selections in both filter domains, while delivering the highest resolution and wide dynamic range with very low noise. Custom gold rotary switches give accuracy in 0.5dB, 1dB and 2dB steps. Avalon's true symmetry design offers high-voltage, large headroom, extended bandwidth, and very low noise for an utterly transparent full bandwidth tool to shape your project.

- High-end dual mono mastering equalizer
- (2) XLR inputs and (2) XLR outputs
- 104 switched frequencies per channel
- All signal routing with sealed silver relays
- Transparent active and passive filter design

### SUMMIT FeQ-50

#SUFEQ50  
**\$949<sup>00</sup>**

The Summit FeQ-50 is a 4-band, parametric passive equalizer that incorporates a 12AX7A vacuum tube in its artful design. Each of the four bands has six switch-selectable frequencies and 14dB of fully sweepable cut or boost. The low and high bands can switch between peaking and shelving filters, the low mid and high mid can switch between narrow and wide bandwidths. Also included is a switchable high-pass filter fixed at 30Hz with a gentle 6dB/octave rolloff to reduce rumble.



- 4-band parametric EQ with fully passive design
- (1) XLR/ 1/4" TRS combo input
- (1) XLR & (1) 1/4" TRS tube output
- (1) XLR & (1) TRS 1/4" solid state output
- Internal high voltage power supply



### MACKIE Quad EQ

#MAQEQ  
**\$979<sup>99</sup>**

- 4 channels of 30-band graphic equalization
- (4) XLR & 1/4" TRS phone inputs and (4) XLR & 1/4" TRS phone outputs
- Stereo linking of channels A/B and C/D
- 99 user snapshots to store and recall your EQ settings
- Planet Earth power supply operates between 100 and 240V

The Quad EQ employs four 30-band graphic, Adaptive-Q Equalizers that provide equalization  $\pm 12$ dB using 30 individual EQ filters, without the ripple and gain-boosting artifacts found on traditional (Constant-Q) units. These Adaptive-Q filters and new, super-accurate LED display ladders paint a highly detailed picture of its effect on the output signal. The included reference microphone allows you to make use of the built-in SPL and RTA metering features to help tune your sound system to the venue.

### BEHRINGER ULTRACURVE PRO DEQ2496

#BEDEQ2496  
**\$299<sup>99</sup>**

The DEQ2496 is a 24-bit/96kHz EQ/RTA processor designed for live PA and studio mastering applications. As well as 61-bands of simultaneous Real-Time Analyzer functions, the unit provides multiple EQ's, a flexible Compressor/Expander with Peak Limiter and a Stereo Imager and Delay.



- High-resolution processor with EQ, RTA and dynamics capabilities
- Unique VPQ (Virtual Paragraphic EQ) allows parametric control of graphic EQ's
- 61-band RTA provides auto EQ function for room and loudspeakers
- Multi-function level meters
- Balanced XLR I/O, stereo aux outputs, AES/EBU and S/PDIF I/O XLR and optical



**ASHLY**  
**MQX-2310**

#ASMQX2310  
**\$480<sup>00</sup>**

The MQX-2310 is a dual 31-band graphic EQ that packs the great performance of Ashly's GQX models in a uniquely compact package. The same exacting filter design and summing circuitry of the GQX Series equalizers are utilized, with each filter exhibiting true constant Q response. The center detented position of every fader acts as an on/off switch for its filter, minimizing any possible degradation to signal noise levels. To take advantage of the full range of their custom-manufactured 25mm slide fader design, there is up to 15dB of cut or boost available on each filter.

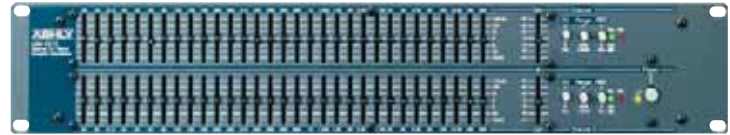

- Dual 31-band graphic equalizer
- (1) XLR, 1/4" TRS phone & Barrier Strip input • (1) XLR, 1/4" TRS phone & Barrier Strip output
- Powerful alternative where rack space is at a premium
- Internal power supply and rugged build quality

**MQX-2150** single rack space 15 band version of above #ASMQX2150.. **\$240.00**



**ASHLY**  
**GQX-3102**

#ASGQX3102  
**\$635<sup>00</sup>**

The Ashly GQX3102 is a premium-quality dual-channel 31-band graphic equalizer. Its near bullet-proof construction, precision Wein-Bridge filters, and highly-accurate transparent sound have made the GQX3102 an industry standard and professional choice of today's most demanding sound engineers.

- Precision Wein-Bridge filters
- Constant "Q"
- Custom-made faders
- Extremely low-noise circuitry
- Switchable, tunable low-cut filters
- XLR, Barrier Strip and 1/4" TRS connectors

**RANE**  
**ME-60S**

#RAME60S  
**\$589<sup>00</sup>**

The Rane ME 60 is a precision dual-channel, 1/3-octave, 30-band graphic equalizer. Its innovative features include constant-Q bandwidth and interpolating equalization, allowing greater isolation of the desired frequency band with little affect to neighboring frequencies, guaranteeing precise control of frequency curves for a smooth, rich, detailed response.



- Stereo 1/3-octave design
- Sweepable low- and high-cut filters
- "True" passive bypass switches
- Grounded center detent sliders
- Balanced XLR, 1/4" TRS and unbalanced RCA connectors



**DBX**  
**2231**

#DB2231  
**\$499<sup>95</sup>**

The dbx 2231 is an affordable dual-channel 31-band graphic equalizer with peak limiting and noise reduction. Its sonic accuracy and rugged construction make the 2231 a perfect choice for small venue PA and sound reinforcement applications.

- Exclusive dbx noise reduction and limiting
- Balanced inputs and outputs
- Four-segment LED's for gain reduction and output level
- Switchable boost/cut ranges
- Bessel low-cut filters
- XLR, Barrier Strip and 1/4" TRS connectors

**DBX**  
**iEQ31**

#DBIEQ31  
**\$599<sup>95</sup>**

The iEQ31 graphic equalizer not only delivers 31 bands of dual 1/3-octave graphic equalization but, also includes feedback suppression, noise reduction, and peak limiting. Sure to find a home in the studio, on tour, and with installed sound venues, this unit was designed to deliver maximum sonic flexibility with a straightforward interface and well-constructed package. The front panel features nonconductive nylon sliders with comprehensive output and gain reduction metering while the rear panel hosts a complete choice of professional connections.



- Dual channel 31-band graphic EQ
- (1) XLR, 1/4" TRS phone & Euroblock input • (1) XLR, 1/4" TRS phone & Euroblock output
- Feedback suppression, noise reduction and peak limiting
- Relay bypass for power failure system protection

**iEQ15** Dual 15 band version of above #DBIEQ15 ..... **\$499.95**

**DBX**  
**231**#DB231  
**\$199<sup>99</sup>**

The 231 dual graphic EQ represents a great value in an entry-level unit with its clean sound, solid performance, and reliability. The 2 rack space design can find a home in the tightest of racks and budgets without compromising the inclusion of professional balanced connectivity and an internal power supply for clean mounting. From its amazing 10Hz to 50kHz frequency response, to its 108dB dynamic range, the 231 offers out-of-this-world specifications with a down-to-earth price point.



- Dual 31-band, 1/3 octave graphic EQ
- Switchable boost/cut ranges of  $\pm 6$  or  $\pm 12$ dB
- (1) XLR & 1/4" TRS phone input and (1) XLR & 1/4" TRS phone output
- 4-segment LED ladders for monitoring output levels
- Front panel bypass switch

**215** Dual 15-band version of above #DB215.....**\$149.95**

**DBX**  
**131**#DB131  
**\$149<sup>99</sup>**

- Single channel 31-band, 1/3-octave graphic EQ
- Switchable boost/cut ranges of  $\pm 6$  or  $\pm 12$ dB
- (1) XLR & 1/4" TRS phone input and (1) XLR & 1/4" TRS phone output
- Only occupies a single rack space
- Internal power supply and solid construction

This single channel graphic EQ was designed as an easy-to-use tool for situations where pinpointing and adjusting choice frequency ranges must be fast and effective. Whether you are trying to tame a muddy bass guitar or give the vocalist a little more presence, the 131 is equally at home at a venue, in the studio, or permanently installed in houses of worship or meeting rooms. With such affordable quality there's no longer any excuse for compromising your sound.

**BEHRINGER**  
**DEQ1024**#BEDEQ1024  
**\$149<sup>99</sup>**

The Ultragraph Digital DEQ1024 is a stereo 31-band equalizer and feedback destroyer that combines unmatched digital performance with straightforward and intuitive analog-like operation. The FBQ Feedback Detection System instantly detects critical feedback frequencies and can also be used as an audio analyzer, making the DEQ1024 a must-have for every professional live sound rack. The EQ section features three selectable operating ranges ( $\pm 12$ dB,  $\pm 6$ dB and 0/-2 dB) and 31 high-quality illuminated 45mm faders for ease of use in dim lighting conditions.

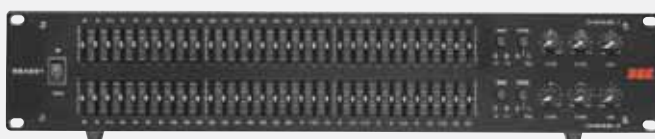

- Digital stereo 31-band 24-bit/96kHz equalizer
- (2) XLR & 1/4" TRS phone analog inputs
- (2) XLR & 1/4" TRS phone analog outputs
- AES/EBU XLR and S/PDIF RCA digital I/O
- Noise gate/peak limiter and pink noise generator

**BBE**  
**EQA231**#BBEQA231  
**\$199<sup>99</sup>**

- Dual channel 31 band graphic EQ
- (2) XLR & 1/4" TRS phone inputs and (2) XLR & 1/4" TRS phone outputs
- Voltage switchable between 115 and 230 VAC
- Constant-Q filters
- True hard-wire bypass
- Signal Clip indicator

**EQA215** dual channel 15-band version of the above #BBEQA215....**\$149.99**

**EQA131** single channel 30-band version of the above #BBEQA131..**\$149.99**

The BBE EQA231 is a high-quality dual 31-band graphic equalizer. It is ideal for use in live sound rigs and installed setups such as studio, stage, DJ, and sound contracting. The EQA231's logical layout makes it a snap to use for room equalization and sound shaping. Also included are continuously variable high- and low-cut filters and a selectable control range allowing musicians to switch easily between 6dB and 12dB on the graphic filters. There are also provisions for selecting line voltage between 115 and 230 VAC.

**BEHRINGER**  
**FBQ1502**#BEFBQ1502  
**\$79<sup>99</sup>**

The Ultragraph Pro FBQ1502 is a 15-band stereo graphic equalizer that is equally at home in both live and studio applications. It features the FBQ Feedback Detection System that instantly detects feedback frequencies and can also be used as an audio analyzer, making the FBQ1502 a welcome addition to any stage rack. It also features a dedicated mono subwoofer output with adjustable crossover frequency that lets you add some extra punch to your music.



- 15-band dual channel graphic equalizer
- (1) XLR subwoofer output with crossover adjustment
- (2) XLR & 1/4" TRS phone inputs and (2) XLR & 1/4" TRS phone outputs
- Low-cut filter removes floor rumble
- Illuminated faders and LED output metering

**FBQ3102** dual channel 31-band version of above #BEFBQ3102.....**\$129.99**

### SAMSON D3500

#SAD3500  
**\$199<sup>00</sup>**

Ideal for stereo PA systems, the easy-to-use D3500 is a 96kHz-capable digital equalizer and automatic feedback management system that provides precise tonal control of 30 bands of parametric filters. The three filter modes: Resonance, Dynamic, and Manual, all utilize a unique Auto Filter Release (AFR) mode, gradually restoring the problem EQ filter when feedback has been eliminated, thereby protecting your system components and sound quality.



- 30-band parametric EQ with advanced feedback management
- 32-bit DSP filtering with high quality A/D-D/A converters
- LEARN mode provides "single-button" system feedback reduction
- Onboard Alignment Delay, High/Low Pass Filters
- Multiple units may be configured together
- Balanced XLR I/O and optional AES/EBU, S/PDIF interface



### DBX AFS 224

#DBAFS224  
**\$299<sup>95</sup>**

- Ideal for virtually all live music applications
- Advanced 24-bit Feedback Suppression processor
- 24 programmable filters per channel with segment metering
- Intuitive interface with selectable Filter Lift Times and Live and Fixed Filter Modes
- Balanced XLR and 1/4" I/O

The AFS 224 is a 24-bit Advanced Feedback Suppression processor that provides 24 filters per channel and up to 1/80 of an octave filter Q's for superior frequency control. It offers selectable modes, live filter lift, and types of filtration, which are all readily available via the intuitive front panel. A must for multiple live sound applications, the AFS 224 even includes application-specific filter types: Speech; Music, Low, Med, and High.

### SABINE FBX1200

#SAFBX1200  
**\$329<sup>95</sup>**

Ideal for mono PA and monitoring systems, the single-channel FBX1200 Feedback Exterminator provides transparent, reliable automatic feedback control with precise SMARTFilter technology, ridding your system of feedback without harming musical content. When feedback is detected, the FBX1200 quickly places high-resolution filters within its 24-bit audio path while the three-color LED filter display shows filter status.



- High-resolution single-channel feedback management system
- Isolates feedback while leaving harmonic musical content untouched
- Quick and quiet setup with extremely-fast Automatic Feedback Control
- Flexible filter controls with Timed or Manual dynamic filter reset
- Balanced XLR and 1/4" I/O

**FBX2400** 2-channel version of above #SAFBX2400 ..... **\$399.95**



### SABINE FBX-SOLO 820 Series

#SASM820  
**\$314<sup>95</sup>**

The FBX-SOLO 820 Series is a convenient, portable solution for eliminating feedback while leaving your sound unharmed. Available in both instrument and microphone versions, the FBX-SOLO provides more gain while placing a narrow 1/10 octave directly on feedback, increasing clarity and intelligibility.

- 8 independent digital notch filters from 40Hz-20kHz
- Automatically detects and eliminates feedback
- XLR version is ideal for worry-free wireless operation
- Input/output level switches allow any combination of ins and outs
- Sets filter just deep enough to remove feedback without affecting audio

**SL-820** 1/4" input version with selectable I/O levels #SASL820 ..... **\$314.95**

### BEHRINGER FBQ2496

#BEFBQ2496  
**\$149<sup>99</sup>**

The FBQ2496 is an affordable 96kHz Feedback Suppressor that utilizes an ultra-fast feedback detection algorithm to automatically locate up to 20 feedback frequencies per channel and transparently set narrow notch filters accordingly. It's capable of running in either Auto or Manual mode for continuous mix monitoring or individual setting of up to 40 fully parametric filters with frequency, bandwidth, and gain adjustment.



- 96kHz Feedback Suppressor with 20 filters (up to 1/60th octave) per channel
- Provides some of the quickest feedback detection available (<0.2sec)
- "Set-and-forget" default setting and Panic button enables simple setup and operation
- 24-bit/96kHz A/D D/A with 32-bit internal DSP
- Balanced XLR and 1/4" I/O

**DSP1124P** 24-bit Feedback Suppressor/EQ with 12 filters per channel #BEDSP1124P .... **\$99.99**



## ROLAND GI-20

#ROG120  
**\$395<sup>00</sup>**



The GI-20 is an interface which allows any electric guitar or bass equipped with a Roland GK pickup to control synthesizers and sound modules as well as record into a MIDI sequencer or trigger samples. Guitarists and bassists can now take full advantage of the wealth of software synthesizers and notation software previously available only to keyboardists.

- Guitar- or bass-to-MIDI interface
- Interfaces directly with synthesizers and computer workstations
- Patch Memory stores performance settings
- USB MIDI port for easy computer connection

**GK3** divided guitar pickup #ROGK3..... **\$175.00**

**GK3B** divided bass pickup #ROGK3B..... **\$175.00**

## LINE 6 Guitar Port

#LIGP2.5  
**\$99<sup>99</sup>**

The Guitarport is a Windows-based USB guitar audio interface that provides guitar players with a simple way to plug into their computer as well as gain access to optional online backing tracks, lessons, tone settings, and much more. 16 amplifier and cabinet models combined with 19 stomp and studio effects give life to your guitar sound when recording or playing along with the audio loop player and programmable drum metronome.



- Windows-based USB guitar modeling interface
- Includes preset tone library
- Half-speed audio playback without changing pitch
- Built-in chromatic tuner
- Optional GuitarPort software increases functionality

## LINE 6 Pocket POD

#LIPP  
**\$129<sup>99</sup>**

The Pocket POD is a personal guitar processing system that delivers all of the sonic punch of the original POD in a very small, super low-priced package. Now it is even easier to get your hands on loads of quality amp simulations and effects with the ability to download thousands of free presets via its built in USB interface. Use it in front of your amp, plug directly into a sound system or use headphones to practice anywhere.



- Portable guitar processor with belt clip
- 32 classic and modern amp models • 16 cabinet models / 16 effect models
- USB connection for managing your patch library • Powered by 4 AAA batteries

## KORG Pandora PX4D

#KOPX4D  
**\$169<sup>00</sup>**



The Korg PX4D is a versatile personal guitar and bass tool that packs amp modeling, multi-effect processing, 100 drum rhythms, bass patterns, and phrase training into a unit that fits into the palm of your hand. The user interface is straightforward, and frequently-used parameters such as tuner and tone are given dedicated buttons and knobs. Play along with up to 30 seconds of internally storable music or connect directly to your recording setup or live rig.

- Guitar and bass personal multi-effects processor
- 25 amp and 23 cabinet emulations
- Key Transpose shifts key of incoming audio
- Bass Cancellor removes bass from external sound source
- Powered by battery or optional AC adaptor

**PX4A** acoustic personal multi-effect processor #KOPX4A ..... **\$169.00**

## WAVES iGTR

#WAIGTR  
**\$80<sup>00</sup>**

The iGTR is an inexpensive miniature portable amp and effects modeling device for guitar players, a sort of pocket-sized, battery-operated Marshall stack. The unit is great for headphone practicing or quick, to-the point direct recording, and is equipped with a generous allocation of control knobs and selector switches, along with inputs for both a guitar and an MP3 or CD player.



- Pocket-sized portable guitar processor
- Amp, modulation and ambience effects models
- Programmable amp and effects settings with dedicated controls and switches
- 1/4" Hi-Z and 1/8" stereo mini input jacks
- (2) 1/8" stereo mini headphone/line outputs for monitoring/recording
- (4) "AAA" battery operation or AC adapter power

LINE 6

Variax 600

#LIV600B \$799<sup>99</sup>

The Variax from Line 6 is truly a remarkable advance forward in the evolution of the guitar. It features internal sound modeling, so with the switch of a knob you can transform the style of guitar you're playing. Instantly swap from Les Paul, Strat, acoustic 12-string, banjo, sitar, 25 sounds in all. The included Workbench software enables you to save custom settings and even switch between alternate tunings.

- Canadian hard maple neck, basswood body
- No pickups and no unwanted hum or noise, just pure tone
- Standard 1/4" guitar output
- Digital connection for integrating with Vetta II or PODxt Live
- Volume and tone controls
- 22 medium profile frets, custom tremolo bridge
- Works with any guitar amplifier



LINE 6

PODxt Pro

#LIPODXTPRO \$699<sup>99</sup>



The PODxt Pro is the big brother in the POD lineup, carrying on where the tabletop PODxt left off. This 2-space rack mountable guitar modeling unit adds an internal power supply, stereo effects loop and balanced I/O. Send a dry unprocessed guitar signal or audio track into the reamping input to change the entire guitar sound, or experiment by manipulating vocals, keys, or anything imaginable.

- 24-bit A/D and D/A converters • MIDI in, out/thru • AES/EBU and S/PDIF I/O
- USB port for computer and software access • Pairs with optional FBV Pedal Board

**FBV Pedal Board** optional deluxe pedalboard #LIFBV.....\$399.99  
**Bass PODxt Pro** bass version #LIBPODXTPRO .....\$699.99

LINE 6

POD X3 Live Pro Floor Pedal

#LIPODX3LIVE \$499<sup>99</sup>

The POD X3 Live is a floor pedal with your choice of 78 guitar amplifier models and 24 different cabs, 98 effects, 28 bass amp models with 22 different bass cabs, and 6 mic preamp models. You can plug in two instruments at once.



Your complete signal chain layout is all visible on one screen. USB 2.0 connectivity allows you to record multiple channels of audio to recording software.

- (1) 1/4" guitar input, (1) 1/8" line input for CD or MP3 player
- (1) 1/4" auxiliary, (1) XLR mic input with trim
- 1/4" effects loop, Variax digital interface jack • S/PDIF output, MIDI I/O, USB 2.0
- (2) 1/4" line, (1) headphone, and (2) XLR direct outputs • Over 200 presets

M-AUDIO

Black Box Reloaded

#MABBR \$199<sup>00</sup>



M-Audio's Black Box Reloaded is an inexpensive 24-bit USB audio interface and music creation tool, combining effects processing, amp modeling, drum pattern presets and a guitar tuner expressed in a compact desktop module with an oversized LCD display. The unit has a high-speed USB port for direct cross-platform computer access and ships with Ableton Live Lite GTR software.

- Compact desktop creation tool for guitarists and songwriters
- 4 multi-function rotary encoder knobs
- 40 amp models, 121 filter and modulation effects, 100 drum patterns
- Tap tempo and external MIDI clock sync for effects and drum patterns
- Windows XP Home and Mac OS v.10.3.7 compatible
- 1/4" Hi-Z and XLR guitar and microphone inputs
- 1/4" analog and Coaxial SPDIF digital outputs

**Black Box Pedal Board** controls Black Box Reloaded effects #MABBPB.....\$49.00

LINE 6

POD X3

#LIPODX3 \$399<sup>99</sup>



The desktop-ready POD X3 turns up the power from the PODxt model with capabilities like a USB 2.0 connection, 78 guitar amplifier models and 24 different cabs, 98 effects, 28 bass amp models with 22 different bass cabs, and 6 mic preamp models, and over 200 presets! You can even plug in two instruments at once and run effects on both and record multiple channels of audio to recording software.

- (1) XLR mic input with trim pot, (1) 1/4" guitar input
- (1) S/PDIF digital output, FBV foot pedal jack
- 1/4" Balanced stereo outputs, headphone output
- USB 2.0 for computer recording
- Complete signal chain layout is all visible on one screen
- Run two rigs or two tones at once

## BOSS MICRO BR

The MICRO BR must in fact be the world's smallest 4-track studio.

Not even an inch thick, this unit features 4 simultaneous playback tracks and 2 record/input tracks. For even more power, each of the 4 main playback tracks has 8 companion virtual tracks (for a total of 32), giving you the ability to record take after take, then pick your best material for final mixdown. With the included 128MB Secure Digital card you have approximately 65 track minutes available for recording in its native MP3 format. This is a unit that should be in every musician's gig bag for documenting quick ideas with its built-in microphone or developing songs with your whole band.

- Ultra-portable 4-track digital studio
- Loads and plays MP3 files
- Multi-effects onboard with dedicated guitar input
- Time-Stretch and Center Cancel features
- 293 rhythm patterns • USB port for data transfer



#BOMBR  
**\$229<sup>00</sup>**

## FOSTEX MR-8HD

The MR-8HD is a stand-alone digital multi-track recorder with an internal 40GB hard drive. It's capable of recording 4 tracks simultaneously, with (4) XLR inputs, and the ability to supply phantom power to each input. There is a USB output that enables you to transfer your files to a PC or a Mac for archiving or burning CD's, etc. It includes internal effects like reverb, delay, and guitar distortion.

- Simple and intuitive user interface and operation
- S/PDIF digital output
- Dedicated guitar input with distortion effect
- (2) headphone output jacks
- Microphone and guitar amplifier simulation
- 128 x 64 LCD display
- Mastering effects



#FOMR8HD  
**\$349<sup>00</sup>**

## FOSTEX MR-8HD/CD



The MR-8HD/CD is an 8-track integrated desktop hard disk recorder and mixer, equipped with an internal 40GB hard drive and a CD-RW drive, and designed as an inexpensive, easily-operated audio and music production solution for songwriters, bands, and event videographers. The unit features 4 XLR microphone preamps with phantom power, built-in microphone and amplifier simulators, and onboard reverb and delay effects processing.

- 8-track digital desktop workstation recorder
- 40GB internal hard drive, built-in CD-RW
- Uncompressed .WAV file format recording
- (4) XLR mic pres with phantom power
- Intuitive work surface for simplified signal routing, mixing
- Built-in analog guitar distortion with dedicated control knob
- USB port for computer integration, SPDIF digital output

#FOMR8HDCD  
**\$399<sup>00</sup>**

## FOSTEX MR-8 MKII



The new MR-8 Mk II is an extremely easy-to-use digital multitrack and, if you can operate a tape recorder, you'll be up and running within minutes of opening the box. By putting all the major controls and functions right there on the top panel instead of buried in a confusing menu system, it speeds up the flow of capturing your musical ideas. In addition, there are great-sounding built-in digital effects, guitar amp and mic simulators, handy mix-down effects, plus the ability to hook up to a PC for data editing, and backing up your songs.

- 8-track compact flash digital recorder
- +48V phantom power on both XLR inputs
- Guitar input features dedicated distortion knob
- USB port for .WAV file transfer to and from your PC
- Accepts off-the-shelf USB external CD-R drives

#FOMR8MK2  
**\$249<sup>00</sup>**

## TASCAM MP-GT1

The MP-GT1 from Tascam is an MP3 version of their popular CD-GT1mkII guitar trainer. You simply attach the MP-GT1 to a computer and load song files onto it. Now you're free to plug in your guitar and jam along with your favorite music wherever you go. Slow down the speed of the song without changing pitch, loop sections of a song to learn all the details, or remove the guitar from the song.

- Built-in tuner, metronome, overdrive and multi-effects
- 1 GB - Store up to 240 songs
- Built-in 9-hour lithium ion battery charges through USB
- Data wheel for easy and fast file navigation
- Buttons to adjust your guitar's volume or song volume
- 0.48 lbs, 3.1 (W) x 4.3 (H), x 1" (D)



#TAMPGT1  
**\$199<sup>00</sup>**



## TASCAM DP-02CF

The Tascam DP-02CF is an 8-track desktop Compact Flash digital recorder with a sleek, high-tech design. The unit features 2 channels of simultaneous recording and a familiar hands-on analog-style mixer sporting dedicated faders, along with pan, EQ and effects send knob controls. The high-capacity CF media have no moving parts, and represent a plentiful and reliable storage solution for modern digital recording.



#TADP02CF  
**\$299<sup>00</sup>**

- 8-track Compact Flash recorder for desktop music production
- Analog-style work surface with dedicated knobs and faders per channel
- Jog Wheel and bright LCD display
- CD-quality resolution, simultaneous 2-channel recording
- (2) XLR Mic/Line inputs, (2) 1/4" Hi-Z instrument inputs
- (2) 1/4" TS Send/Return jacks for effects processors
- USB, MIDI and Optical digital outputs

## BOSS BR600



The BR-600 is a portable 8-track digital recording studio with an incredibly slim profile, making it ideal for rehearsals or field recording. It is equipped with advanced effects, COSM amp modeling, a built-in stereo mic and a full-fledged drum machine. This versatile flash recorder provides a total of 64 tracks and up to 65 minutes of Hi-fi recording time.

#BOBR600  
**\$349<sup>00</sup>**

- Compact Ultra slim design
- 8 simultaneous playback tracks, 64 V-Tracks
- Powerful guitar and effects processor
- Built-in stereo Mic
- USB for computer connectivity
- Powers via: (6) AA batteries or AC adapter
- Includes: 128MB compact flash card, carrying case, and XLR, 1/4" adapter

## ZOOM MRS8

Featuring two tracks of simultaneous recording, built-in vocal and mastering effects, and a great sounding drum/bass machine with touch-sensitive pads, the compact MRS8 is an inexpensive all-in-one portable digital multi-track recorder. It's conveniently battery-operated and records up to 1GB of uncompressed audio (8 tracks total) onto low-cost SD memory cards via the XLR combo jack or switchable Hi/Lo-Z 1/4" input. It even features a handy mini-condenser microphone on its top for truly portable songwriting capabilities.



#ZOMRS8  
**\$299<sup>00</sup>**

- 8 physical tracks with 10 virtual takes available per track, 2 tracks of simultaneous recording, 11 simultaneous playback tracks including 2(Stereo) Drum Tracks and 1(Mono) Bass track
- XLR 1/4" combo jack, switchable Hi/Lo-Z 1/4" instrument input
- Editing includes copy, move, erase, bounce and more
- (8) slider mixer

## ZOOM HD8CD



#ZOH8CD  
**\$499<sup>00</sup>**

The Zoom HD8CD is a compact 8-track desktop hard disk recorder and control surface with an 80GB internal hard drive and CD-RW deck. The unit allows for 2-channel simultaneous recording and 80 virtual tracks, offering 3 additional playback tracks from the internal drum and bass rhythm generator. A high-speed USB connector allows for use of the machine as a computer DAW control surface – a great value.

- 8-track desktop hard disk recorder with internal 80GB hard drive
- Full-function DAW remote control surface with USB connector
- 80 virtual tracks, 2-channel simultaneous recording
- 3 additional playback tracks from internal rhythm generator
- 130 built-in effects and 370 DSP patches
- Built-in CD-RW drive for mixdown, backup
- (2) XLR/1/4" combo inputs, MIDI I/O
- SPDIF digital I/O, Cubase LE software supplied

## KORG D888



#KOD888  
**\$699<sup>00</sup>**

The D888 is a 40GB, USB 2.0-equipped hard disk recorder that combines ease of use with powerful digital features like: 8-track simultaneous recording, high-speed .WAV data transfer with your computer, and internal 40-bit processing. The master effect has its own dedicated selection knob and the metronome can be sent out of the monitor outputs.

- 8 track simultaneous recording/playback
- 8 virtual tracks per audio track
- (8) XLR & 1/4" TRS inputs
- Gain, EQ, effects sends and pans per channel
- Optical S/PDIF output
- Maximum 140 hours of record time
- Internal hard drive mounts to your computer desktop
- USB 2.0 port-Windows and Mac compatible

## BOSS BR900CD

The BR900CD is a reliable all-in-one digital recorder with professional effects, a drum-pattern generator, vocal-correction and Master Tool Kit, digital output, and internal CD burner. Use up to 64 virtual tracks to write, record, edit, and mix a complete, polished CD anytime. For the musician on the go, the BR900CD provides convenient Compact Flash storage and even provides battery power and digital connection/transfer capabilities for a truly portable recording system.

- 8 simultaneous playback/2 simultaneous recording tracks with 64 virtual tracks total
- (2) XLR inputs with phantom power, 1/4" and RCA inputs, digital out (optical)
- High-quality effects for processing and mastering
- Programmable drum generator with 294 patterns
- Record direct to Compact Flash (up to 1GB) and direct to CD-R/RW • USB port for .WAV file transfer, importing/exporting, and data backup

## BOSS BR-1600CD



The BR-1600CD is a 16-track desktop hard disk workstation with a 40GB internal hard drive and a CD-R/RW, designed as a self-contained music production studio. The unit features 8 phantom-powered mic preamps with dedicated compressors, 16 individual track EQ's, built-in COSM modeling effects, and Auto Pitch correction. That's a fraction of the machine's capabilities. The BR-1600CD offers high-quality sound for the budget-minded.

- 16-track desktop hard disk recorder with internal 40GB hard drive • Built-in CD-R/RW drive
- Up to 8 simultaneous recording tracks
- Mixer section with 13 faders, built-in drum sequencer with massive library • Built-in GT-6 guitar and bass effects processor, Mastering Toolkit
- Built-in Vocal Toolbox voice processor/pitch corrector
- (8) XLR mic pres with phantom power
- USB connectivity with WAV/AIFF file support

#BOBR900CD  
**\$695<sup>00</sup>**

## FOSTEX MR-16HD

The MR-16HD offers a simplified approach to a stand alone 16-track multi-track recorder. Featuring a 40GB hard drive, (4) XLR and 1/4" inputs, onboard effects, and aux sends. The workflow is intuitive and many tasks are a single button push away. USB output allows connection to a computer to transfer to files, or connect a CD burner and avoid computers altogether.

- 4-track simultaneous recording with phantom power
- (4) XLR inputs, (1) dedicated guitar input with distortion effect
- S/PDIF digital output • EQ library with 33 presets for all inputs
- Built-in Digital effects including reverbs and mic/amp simulations
- (2) headphone jacks

#FOMR16HD  
**\$349<sup>00</sup>**



## YAMAHA AW1600



The AW1600 is a self-contained digital audio workstation that features 8 combo inputs (all with Phantom power), USB 2.0 drag-and-drop capabilities for moving files onto your computer, 24-bit recording and a new Pitch Fix algorithm for correcting the pitch of vocal tracks. If you are a musician on the move, or with limited "studio" space, you will want maximum performance and functionality with minimum size, weight, and setup hassles. The AW1600 proves extraordinary

music production power in a remarkably compact, all-in-one unit that can take you all the way from inspiration to finished CD.

- 8-input/16-track workstation with USB 2.0 interface • 8 virtual tracks per physical track
- Built-in CD-RW for creating audio and data backup CD's • Quick loop sampler with preset rhythm phrases • (2) high-performance assignable effects processors

#YAAW1600  
**\$999<sup>00</sup>**

## BOSS BR1200CD

Featuring an intuitive layout and icon-based user interface, the BR1200CD is a portable and versatile hard-disc recorder capable of 12 simultaneous playback tracks. It combines a powerful drum and bass programmer, COSM effect modeling, and studio multi-effects with a Mastering Tool Kit for polishing mixes. Store, import/export, backup, and burn data/audio easily via the built-in hard drive, USB port, and CD-burner.

- 12 playback/2 record tracks (simultaneous)
- (2) XLR inputs with phantom power, 1/4" and RCA inputs, digital out (optical)
- High-quality COSM/multi-effects for processing including Mastering and Vocal Tool Boxes
- Built-in drum and bass machine with 600 patterns and easy audio loop importing with Auto Tempo Matching • 40GB internal HD, USB port

#BOBR1200CD  
**\$895<sup>00</sup>**





### TASCAM 2488mkII

#TA2488MK2  
**\$799<sup>00</sup>**

The 2488mkII is an inexpensive 24-track desktop workstation recorder with 24-bit resolution, an 80GB internal hard disk and a built-in CD-R/RW drive. The unit offers 8 simultaneous tracks of recording, 250 virtual tracks, 4 phantom-powered XLR combo mic inputs, and a sub-mixer with 8 additional tracks for mixdown. Each channel is equipped with 3-band EQ and 3 effects sends.



- 24-track desktop hard disk recorder with 80GB internal drive
- 16- or 24-bit WAV recording resolution
- Built-in CD-RW, full-function editing, 999 levels of undo/redo
- 20 physical faders, 12 mono and 6 stereo channels
- 8-track sub-mixer for 32 total mixdown tracks
- Built-in reverb and multi-effects processing
- (4) XLR combo mic pres with phantom power, (4) 1/4" mic/line ins
- MIDI I/O's, USB, Coaxial SPDIF digital I/O's, MTC, MMC and MIDI Clock

### KORG D3200

#KOD3200  
**\$1299<sup>00</sup>**



The flagship D3200 is the first digital recorder in its class to provide up to 32 tracks of simultaneous playback and up to 12 tracks of simultaneous recording to support high channel-count projects such as recording a live band. The powerful mixer section includes 40 input channels plus a great set of high-quality effects that employ Korg's renowned "REMS" modeling technology. The new and interactive

"Session Drums" allow you to easily create a realistic and natural drum track for your entire song and the built in CD-RW let you produce production-ready CD's.

- 32-track digital recording studio with 40GB hard drive
- High-resolution 320 x 240 pixel backlit LCD
- Powerful flexible 12 bus 44 channel mixer
- Four-band EQ on channels 1 through 24
- USB 2.0 for computer data exchange

### YAMAHA AW2400

#YAAW2400  
**\$1999<sup>00</sup>**

The AW2400 has everything needed to record your music anytime, anywhere in a compact, road-worthy design. It features 24 simultaneous tracks of playback, motorized 100mm faders, and the same expansion slot found on Yamaha's digital mixing consoles for connecting the AW to professional studio gear. The AW2400 proves that an audio workstation that is easy to use can also offer professional-class features and performance for music production. Once you have learned the basics you can efficiently go from concept to CD while concentrating on the music rather than the technical details.



- (16) input 24-track digital recording studio
- (8) XLR and (8) 1/4" TRS phone inputs
- Uncompressed 16/24-bit recording at 44.1/48kHz
- 4-band EQ and dynamics processing on all mixer inputs
- Full-length motorized 100mm faders
- USB 2.0 for data transfer with your computer

### FOSTEX MR-16HD/CD

#FOMR16HDCD  
**\$499<sup>00</sup>**



The MR-16HD/CD from Fostex is a 16-track desktop digital hard disk recorder equipped with a 40GB internal drive and built-in CD-RW for master mixes and track backup. The unit supports the FAT32 and WAV disk and file formats, and sports an intuitive work surface designed for quick operation. This is a great buy for songwriters, bands, and event videography post facilities on a budget.

- Compact 16-track desktop hard disk audio recorder
- 4-track simultaneous recording
- (4) phantom-powered XLR mic preamps
- Intuitive knobs-and-faders work surface
- Comprehensive backlit LCD display
- Built-in effects processor with reverb, delay, amp modeling and mic simulation
- Optical SPDIF digital out, USB, (2) 1/4" headphone outputs

### TASCAM X48

#TAX48  
**\$4499<sup>00</sup>**



The X48 is a professional 48-track desktop or rack mount hard disk recorder with an 80GB internal hard drive, a built-in DVD burner, and 24-bit/96kHz recording resolution. The unit sports intuitive turn-key operation, individual track metering, and supports AAF file transfers to most major DAW programs. The X48 also offers SMPTE time code and video clock connectivity, along with TDIF and SPDIF digital I/O's.

- 48-track recording in time-stamped BWF file format
- 80GB internal hard drive, built-in DVD+RW for backup
- Per-channel dynamics DSP, 4-band EQ, (4) VST plug-in inserts
- TDIF, SPDIF, MIDI, SMPTE and Video Clock connectivity
- BWF recording, AAF, and Open TL file transfers
- USB, FireWire and Ethernet connectors for external storage



## BENCHMARK ADC-1

#BEADC1  
**\$1775<sup>00</sup>**

The ADC-1 is a two-channel 24-bit /192-kHz. It provides (2) XLR analog inputs, AES/EBU, S/PDIF and ADAT digital outputs and front panel gain controls and total isolation of the conversion clock in all modes of operation. This pristine converter is ideal for mastering, home recording studios, location recording, and broadcast facilities.



- Reference Locks to AES, S/PDIF, WC, or Super-clock
- 44.1, 48, 88.2, 96, 176.4, and 192kHz at 24-bit
- 9-Segment, Dual Range LED Meter, with Peak Hold
- 1 RU high, half-rack wide
- BNC to RCA adapters included
- EMI and RFI filtering
- Internal switching power supply



- Ideal for mastering studios and high quality recording studios
- Locks to AES, Super Clock, or Word Clock external clock
- AES/EBU (XLR & coaxial) and S/PDIF (XLR, coaxial, & Toslink) inputs
- Stereo XLR and RCA outputs
- 116dB signal-to-noise ratio
- 1 RU high, half-rack wide
- Internal switching power supply

## BENCHMARK DAC-1

#BEDAC1  
**\$975<sup>00</sup>**

The DAC-1 is a two-channel 24-bit /192-kHz digital-to-analog audio converter. It provides AES/EBU (XLR & coaxial) and S/PDIF (XLR, coaxial & Toslink) digital inputs and both RCA & XLR stereo analog outputs. The DAC-1 features Benchmark's jitter-free UltraLock system, auto-processing of pre-emphasized digital audio and a high-quality headphone amplifier.

## LUCID AD9624

#LUAD9624  
**\$799<sup>00</sup>**

The AD9624 is a high-resolution, 24-bit/96kHz analog-to-digital audio converter with simultaneous AES3 (XLR), S/PDIF (coaxial), and S/PDIF (TOS-LINK) digital outputs. It is equipped with stereo XLR analog inputs, Word Clock sync and separate or linkable input level with 20-segment LED. The AD9624's noise-shaping function enhances the clarity of low-level material for superior imaging and realism when creating 16-bit masters.



- Stereo 24-bit, precision A/D conversion
- Ideal for recording, mastering, and post
- User-selectable, 16-bit noise shaping
- Dynamic range: >114dB, A-weighted
- Separate or linkable input level with 20-segment LED
- 1 RU high, half-rack wide
- Optional RM-4 rack mount tray



- Stereo 96kHz D/A conversion
- Dynamic Range: >114dB, A-weighted
- Locks to sample rates of 32, 44.1, 48, 88.2 and 96kHz
- Front panel headphone output with level control
- 20-segment output level LED ladders
- 1 RU high, half-rack wide
- Optional RM-4 rack mount tray

## LUCID DA9624

#LUDA9624  
**\$599<sup>00</sup>**

The DA9624 is a high-resolution, stereo 96kHz digital-to-analog audio converter with separate headphone volume control and line out. It is equipped with three selectable digital inputs: AES/EBU (XLR), S/PDIF (coaxial) or S/PDIF (TOSLINK) and stereo XLR and 1/4" TTS outputs. The DA9624's easy-to-read, 20-segment LED ladders show you exactly where to set I/O controls for optimal digital-to-analog conversion.

## LYNX Aurora 8

#LYAURORA8  
**\$1995<sup>00</sup>**

The Aurora 8 is an 8-channel, mastering quality A/D-D/A converter with an on-board 32-channel digital mixer that provides extensive routing and mixing options. This 24-bit/192kHz converter utilizes Lynx's proprietary SynchroLock jitter reduction technology; an exclusive feature that provides extreme jitter reduction of up to 3000:1. All analog and digital connections used B25 connectors with industry standard pin outs which are compatible with off-the-shelf cables.

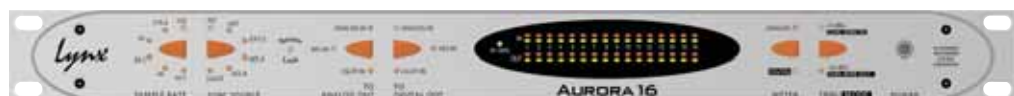

- Simultaneous 8-channel analog I/O & 8-channel AES/EBU I/O
- Onboard digital mixer provides flexible I/O routing
- dB25 connectors for digital & analog I/O
- Word Clock I/O with Lynx SynchroLock jitter reduction technology
- Extensive remote control capability via Lynx AES16, IrDA and MIDI
- LSlot expansion slot for ADAT & future interface options

**Aurora 16 16-channel version #LYAURORA16..... \$2995.00**

**APOGEE**

**Rosetta 800/192**

#APR800192  
**\$2695<sup>50</sup>**



The Rosetta 800/96K is an 8-channel, 24-Bit/192kHz A/D-D/A converter with analog, AES/EBU, and Word Clock I/O. It combines Apogee's legendary conversion quality with their "Softlimit," "UV22HR," and "Intelliclock" technologies. This high-resolution converter is ideal for professional applications yet economical enough for serious project studios.

- 8-channels of premium 24-bit AD/DA conversion
- Balanced analog I/O and AES/EBU I/O on dB25 connectors
- ADAT/SMUX I/O
- SoftLimit: maximizes levels, minimizes overs
- UV22HR: dither down with 24-bit detail
- Word Clock in and out
- Optional X-FireWire and X-HD expansion cards
- Internal switching power supply

**Optional X-FireWire Card #APXFW400** ..... **\$355.50**  
**X-HD Card for Pro Tools HD #APXDH** ..... **\$535.50**



**APOGEE**

**Rosetta 200**

#APR200  
**\$1795<sup>50</sup>**

The Rosetta 200 is a 2-channel, 24-bit/192kHz A/D-D/A solution that features premium Apogee converters, optional Pro Tools HD, Mix & FireWire expansion cards and exclusive Apogee technologies such as "UV22HR," "SoftLimit," and "CODA." It is equipped with XLR analog I/O, AES, S/PDIF (coaxial & optical), and DAT/SMUX I/O and Word Clock & MIDI in and out.

- 2 channels of premium 24-bit AD/DA conversion
- 2 channels of AES, S/PDIF (coax & optical), and ADAT/SMUX I/O
- "CODA": "Aptomizer" level normalizer, Sample Rate Conversion (SRC) and "UV22HR" dither
- "Soft Limit" for maximum digital level without overs
- Optional X-FireWire and X-HD expansion cards
- Internal switching power supply

**Optional X-FireWire Card #APXFW400** ..... **\$355.50**  
**X-HD Card for Pro Tools HD #APXDH** ..... **\$535.50**

**BENCHMARK**

**DAC1 PRE**

#BEDAC1PRES  
**\$1575<sup>00</sup>**



The Benchmark DAC1 PRE is a 2-channel stereo preamp, headphone amplifier and computer audio playback device with a high-res 24-bit 192kHz digital-to-analog conversion system. The unit features a jitter-immune, artifact-free clock system, plug-and-play 24-bit/96kHz USB connectivity, and reference-quality headphone amplification. The DAC1 PRE is a must-have for the well-heeled audiophile or finicky studio owner.

- 2-channel 24-bit/192kHz stereo preamp, headphone amp and USB playback unit
- Proprietary internal clock free from jitter-induced audio artifacts
- 24-bit/96kHz USB audio interface with plug-and-play functionality
- (2) 1/4" TRS front-panel headphone outputs, reference-quality headphone amp
- (3) Coaxial SPDIF and (1) Optical digital ins, USB computer input
- (2) RCA stereo analog inputs
- (2) XLR balanced and (2) RCA unbalanced stereo analog outputs



**APOGEE**

**AD-16X**

#APAD16X  
**\$3145<sup>50</sup>**

The AD-16X is a high quality, 16-channel analog-to-digital audio converter with an optional FireWire card and Pro Tools HD card available. This rack mount, 24-bit/192kHz converter features "Soft Limit" for maximum digital level without overs, "UV22HR" dithering and Direct Digital Synthesis (DDS) using Big Ben's C777 Clock Technology. Its Analog inputs and AES/EBU digital outputs are on standard dB25 connectors.

- 16 channels of balanced analog input
- 16 channels of AES, ADAT/SMUX output
- Word Clock in and out
- Adaptive Loop Filtering (ALF)
- Post A/D conversion level monitoring
- Optional X-FireWire and X-HD expansion cards
- Internal switching power supply

**Optional X-FireWire Card #APXFW400** ..... **\$355.50**  
**X-HD Card for Pro Tools HD #APXDH** ..... **\$535.50**

**ATI**

**DM200**

#ATDM200  
**\$538<sup>95</sup>**

The DM200 is a high-quality D/A converter/headphone tap designed for analog monitoring of a digital signal. It accepts loop-thru AES/EBU format digital audio data via 110-ohm XLR and 75-ohm BNC and RCA connectors, and a 24-bit/96kHz D/A converter feeds stereo headphone drivers, balanced audio line outputs, and a stereo LED meter.

- Accepts sample rates from 27- 96kHz
- Loop-thru inputs, transformer isolated
- Signal Valid indicator
- 24 Bit D/A converter
- D/A and line output metering
- Stereo headphone and line outputs



*Requires WA100-1 wall mount power supply #ATWA1001* ..... **\$14.95**

**RME****ADI-192 DD**#RMADI192  
**\$1599<sup>00</sup>**

The ADI-192 DD is a high-resolution, format converter that consists of three 8-channel converters with 24-bit audio resolution and sample rate conversion at rates up to 192kHz. It provides simultaneous ADAT, TDIF and AES inputs and outputs, with flexible internal routing that allows any of the input formats to be independently assigned to any of the output formats.



- (4) XLR AES/EBU I/O
- (2) ADAT TosLink optical I/O
- Front panel TosLink optical S/PDIF I/O
- AES/EBU/TDIF front-end for RME's digital I/O cards
- "SteadyClock" proprietary clock technology
- Word Clock in and out
- 1U rack mount chassis

**RME****ADI-2**#RMADI2  
**\$799<sup>00</sup>**

The ADI-2 is a two-channel A/D-D/A converter that provides flexible connectivity in a compact, half-rack chassis. It is equipped with RME's latest generation converters; 1/4" TRS /XLR Neutrik combo-jack analog inputs, and separate stereo XLR & 1/4" analog outputs. SPDIF, AES and ADAT digital inputs and outputs are supplied, with sampling frequencies of up to 192kHz.

- (2) XLR/1/4" TRS Neutrik Combo inputs
- (2) XLR & (2) 1/4" TRS outputs
- ADAT & S/PDIF/AES digital I/O
- "SteadyClock" proprietary clock technology
- Front-panel headphone output with level control
- Two-channel level meter with 6 LEDs
- Accepted power supply voltage: DC 8 V – 28 V, AC 8 V – 20 V

**BEHRINGER****Ultragain Pro-8 Digital ADA8000**#BEADA8000  
**\$249<sup>00</sup>**

The ADA8000 is an 8-channel A/D and D/A converter with built-in IMP microphone preamplifiers and ADAT optical I/O. This compact rack mount unit provides (8) XLR microphone inputs with trim controls, (8) 1/4" TRS inputs and Word Clock synchronization. This unit is an affordable input expansion solution for digital multi-track recorders and digital audio workstations.



- (8) XLR microphone preamps with phantom power
- (8) 1/4" TRS line inputs
- (8) XLR outputs
- ADAT optical I/O
- Master/locked (slave) front panel LED display
- External synchronization via Word Clock or ADAT input

**SM PRO AUDIO****ADDA 192**#SMADDA192  
**\$499<sup>00</sup>**

The ADDA 192 is a two-channel 24-bit bi-directional analog-to-digital converter, featuring dual phantom-powered microphone preamps with separate -20dB pads. The unit is equipped with XLR and 1/4" analog connectors and both coaxial and optical SPDIF digital I/O's. The extremely low-jitter converters support multiple sample rates of up to 192kHz, and the unit sports a headphone amplifier with its own volume control.

- Two-channel, 24-bit A/D/D/A converter with dual 48V mic preamps
- (2) XLR balanced, (2) 1/4" unbalanced analog inputs
- SPDIF coax and optical I/O's
- Zero-latency hardware monitoring with analog/digital input mix balance
- Headphone amplifier with dedicated level control
- Selectable 44.1, 48, 96 and 192kHz SRC

**M-AUDIO****ProFire Lightbridge**#MAPFLB  
**\$399<sup>00</sup>**

The ProFire Lightbridge provides a cost effective means to integrate 32 channels of digital lightpipe inputs and outputs to DAW software through a firewire connection. A MIDI in/out and coax S/PDIF breakout cable is included. The rear panel includes (2) 1/4" TRS outputs, with an output volume control knob on the front. A headphone jack and volume knob are also included on the front.



- Compatible with Pro Tools M-Powered software
- Supports 16 and 24 bit rates
- Mac and PC compatible
- 32 channels of lightpipe at 44.1 and 48kHz
- 16 channels of lightpipe at 88.2 or 96kHz
- Front panel LED indicators
- Kensington lock slot



RME

ADI-4 DD

The ADI-4 DD is an 8-channel AES to ADAT and ADAT to AES format converter with built-in jitter suppression and support for up to 24-bit/96kHz. It is equipped with AES/EBU I/O (one XLR & four viadB-25 connector), two ADAT optical I/Os and Word Clock in and out. RME's proprietary "SteadyClock" technology guarantees excellent performance in all clock modes.

#RMADI4DD  
\$799<sup>00</sup>

- 8-channel AES and ADAT I/O
- AES-3 I/O via (1)XLR & (4) ondB-25 connector
- (2) ADAT ports 32 kHz up to 96 kHz (S/MUX)
- 2nd ADAT port can be switched to SPDIF I/O



- "SteadyClock" proprietary clock technology
- Word Clock in and out
- Accepted power supply voltage: DC 8 V – 28 V, AC 8 V – 20 V



M-AUDIO  
Co2

#MACO2  
\$59<sup>95</sup>

The Co2 is a compact and rugged digital problem solver designed to convert S/PDIF signals from optical to coaxial and coaxial to optical at up to 24-bit/96kHz. It operates as a full-duplex, bi-directional converter, or as a half-duplex converter with "thru" port; allowing it to work as both a converter and a repeater.

- Converts between optical and coax S/PDIF
- Stereo Toslink optical and coaxial digital inputs
- May also be used as a repeater to extend cable runs
- Toslink optical and coaxial digital outputs always active
- Transformer-isolated RCA jacks prevent system ground loops
- 9V power supply included
- 3 1/2 x 2 5/8 x 1 3/8" (WxDxH).45lbs

ATI

DMM-100

The DMM-100 is a digital level, impedance, and connector matchmaker box. It outputs a clean copy of the original data stream that gets connected to it. Featuring AES/EBU, S/PDIF, BNC, and Toslink optical inputs and outputs, it's a handy tool for connecting various consumer and professional electronics. It's wired to eliminate ground loop hum and can readily handle audio rates up to 96kHz.

#ATDMM100  
\$232<sup>95</sup>

- AES/EBU, S/PDIF (digital RCA), BNC, and optical Toslink I/O
- Green "signal present" LED illuminates when data is output
- Front panel on/off power switch
- Handles sampling rates from 27 to 96kHz
- Low signal delay & jitter



**WA100-1** Power supply required for operating the DMM-100 #ATWA1001.....\$14.95  
**DMM100BAT** Battery operated version of the DMM-100 #ATDMM100BAT.....\$268.95

HOSA

ODL-276A



The ODL-276A is a compact format converter for interfacing coaxial S/PDIF gear with Toslink style fiber optical inputs and vice versa. The maximum sampling rate is 24-bit/96kHz, the required power supply is included, and the ODL-276A is not compatible with the ADAT lightpipe protocol.

#HOODL276A  
\$69<sup>95</sup>

HOSA

ODS-330



The ODS-330 is compact Toslink (optical S/PDIF) input switcher/router that allows users to choose between two signal sources via the side mounted switch. The maximum sampling rate is 16-bit/48kHz, the required power supply is included, and the ODS-330 is not compatible with the ADAT lightpipe protocol.

#HOODS330  
\$39<sup>50</sup>

HOSA

CDL-313

The CDL-313 is an inexpensive digital interface that allows simultaneous, bi-directional 2-channel transfer of digital audio on either XLR AES/EBU or RCA SPDIF connectors. Great for applications involving unmatched device connectors and protocols, this handy little box also disables SCMS copy protection during SPDIF to AES/EBU transfers.



#HOCDL313  
\$64<sup>95</sup>

HOSA

ODL-312

The CDL-312 is a compact format converter that allows Toslink (optical S/PDIF) signals to be sent to devices with AES/EBU input/outputs and vice versa. Maximum 16-bit/48kHz sampling rate.

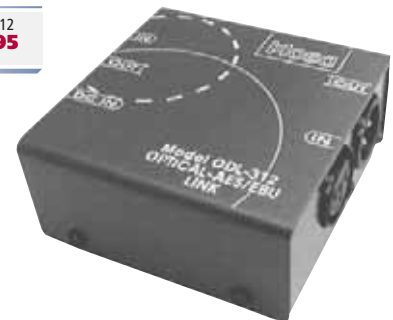

#HOODL312  
\$64<sup>95</sup>

## APOGEE BIG BEN

Big Ben is an extremely accurate 192kHz Master Clock with real-time format conversion. Apogee's new ultra-stable C777 clock uses an entirely digital process to aggressively reduce jitter, delivering amazing clarity and quality to digital audio recordings.



- AES, S/PDIF, Optical I/O-Word Clock/Video In, (6) Word Clock Outs
- Optional X-Firewire and X-Video expansion cards
- "Surelock" technology for drop out prevention
- Sampling rates: 44.1, 48, 88.2, 96, 176, 192 - Video: PAL/NTSC/60Hz.
- Pull up/down 0.1% and 4% from any sample rate
- "Superclock" (256fs)
- Internal switching power supply

#APBIGBEN  
**\$1345<sup>50</sup>**



- Single rack space, ultra-low jitter studio master clock
- (8) Word Clock, (4) AES clock outputs, (2) S/PDIF outputs
- WordClock and (1) AES clock input
- Simultaneously generate/distribute multiple sample rates • Generates 44.1-192 kHz, distributes 28-216 kHz

## LUCID GENx192

The GENx192 is an advanced, affordable master clock that is perfect for multi-track recording, mastering, on-air, DAW, and desktop recording environments. With features like Jitter Input Filtering, drop-out protection, termination sensing, flexible format conversion, the world's easiest interface, and the ability to output two simultaneous frequencies up to 192 kHz, the GENx192 is designed without compromise, destined to become a classic. Let's face it—all jitter is measurable and this unit will output a clean, ultra-low jitter, rock solid clock.

#LUGENX192  
**\$699<sup>00</sup>**

## JL COOPER PPS-2

The PPS-2 is a versatile low-cost synchronizer and SMPTE time code generator. The unit allows tape sync for current hard disk recording systems or legacy drum machines and sequencers, providing Smart FSK and Song Position Pointer functionality while reading and converting MIDI time code. The unit offers SMPTE jam sync and regeneration along with Direct Time Lock and selectable frame rates.

- Cost-effective SMPTE reader/generator with selectable frame rates
- Smart FSK and SPP support for legacy drum machines or sequencers
- MTC read, conversion • Jam sync/regeneration and flywheeling • Sync LED

#JLPPS2  
**\$218<sup>50</sup>**



## HOSA WDC-427

The WDC-427 is an inexpensive, four-output, internal reference clock generator. The unit outputs Word Clock at 44.1, 48, 88.2 and 96kHz sample rates, and supports both 16-bit and 24-bit resolution. Four individually-buffered 75-ohm and TTL level outputs are available on BNC connectors.

- (4) Word Clock outputs (BNC)
- Supports both 16 & 24-bit resolution
- Supports rates of 44.1, 48, 88.2 and 96kHz
- LED illuminates when clock output is present
- Includes 9V power supply

#HOWDC427  
**\$103<sup>95</sup>**

## MOTU Midi Timepiece AV

The MIDI Timepiece is an 8 MIDI in, 8 MIDI out USB interface/patchbay/merger with an integrated synchronizer. It provides video genlock, ADAT sync, Word Clock sync and Digidesign superclock.



- (8) MIDI ins (8) MIDI outs, 128-channels
- ADAT sync out, Word sync out, and Video Sync in
- 128-scene, battery-backed memory
- Bus-powered from USB connection
- Windows and Mac compatible

#MAMTPAVUSB  
**\$499<sup>95</sup>**

### MOTU MIDI Express 128

#MAME128  
**\$235<sup>00</sup>**



The MIDI Express 128 is a rack mount 8 MIDI in/9 MIDI out USB MIDI interface that provides 128 MIDI channels and is powered via USB.

- (8) ins (9) outs, 128 MIDI channels
- Bus-powered from USB connection
- Mac OS9, OS X, and Windows Me/2000/XP compatible

### EMU Xmidi 2x2

#EMXM2X2  
**\$39<sup>95</sup>**



The EMU Xmidi 2x2 is a compact, inexpensive USB/MIDI interface. This miniature bus-powered device is equipped with 2 independent MIDI inputs and outputs for a total of 32 channels of MIDI transmission. The unit features status LED's for each I/O, and supports the MME, CoreMIDI and DirectMusic protocols.

- Portable 2-in/2-out USB bus-powered MIDI interface
- LED status indicators for all MIDI ins and outs
- Filters Active Sensing messages
- Fast MIDI response, multiple device support

### MOTU FastLane USB

#MAFLUSB  
**\$69<sup>95</sup>**



The FastLane USB is a compact 2 x 2 USB MIDI interface with a MIDI thru button that allows you to play to your gear even when your computer is turned off.

- (2) MIDI ins (2) MIDI outs, 32 channels
- MIDI thru button
- Bus-powered
- Windows and Mac compatible

### MOTU Micro Lite

#MAML  
**\$139<sup>00</sup>**



The Micro Lite is a 5 MIDI in, 5 MIDI out USB MIDI interface that provides 80 MIDI channels and is powered via USB.

- (5) ins (5) outs, 80 MIDI channels
- Bus-powered from USB connection
- Mac OS9, OS X, and Windows Me/2000/XP compatible

### M-AUDIO MidiSport 1x1

#MAMS11  
**\$39<sup>00</sup>**

The MidiSport 1x1 is a 1 MIDI in, 1 MIDI out, USB MIDI interface that handles 16 discrete MIDI input and output channels that is bus powered via the USB port.



- (1) in (1) out, 16 discrete channels
- USB cable included
- Windows 98SE/Me/2000/XP and Mac OS 9.2.2/OSX compatible

### M-AUDIO MIDISPORT 2x2

#MAMS22  
**\$69<sup>00</sup>**

The MIDISPORT 2x2 is a 2 MIDI in, 2 MIDI out USB interface that powers via USB (requires no external power supply). Its stand-alone mode allows users to operate MIDI gear even when their computer is off.



- (2) MIDI in, (2) MIDI out, 32 channels
- MIDI thru button
- Windows and Mac compatible

**MIDISPORT 4x4 4MIDI in/4MIDI out version, 64-channels**  
#MAMS44.....**\$149.00**



### M-AUDIO UNO

#MAUNO  
**\$39<sup>00</sup>**

The UNO is an ultra-compact 1 MIDI in, 1 MIDI out, bus powered USB MIDI interface with built in MIDI & USB cables.

- (1) in (1) out, 16 MIDI channels
- Built-in USB and MIDI cables
- Windows 98SE/Me/2000 and Mac OS9.2.2/OS X compatible

### TAPCO Link-MIDI

#TALM44  
**\$119<sup>99</sup>**



The Link-MIDI is a 4 MIDI in, 4 MIDI out USB interface designed for both portable and desktop applications. Its unique swivel foot design allows it to stand on its side in tight workspaces, and soft rubber sides & front-panel side rails protect it from damage while in transport.

- (4) MIDI ins, (4) MIDI outs, 64-channels
- MIDI Thru functionality
- Front panel MIDI activity indicators
- Windows and Mac compatible

### EDIROL UM-1EX

#EDUM1EX  
**\$39<sup>00</sup>**

The UM-1EX is a plug-and-play USB-powered MIDI interface with 1 MIDI in, 1 MIDI out, and built-in MIDI and USB cables.



- (1) in/(1) out, 16 MIDI channels
- Midi Thru switch
- USB bus-powered
- Windows 98/Me/2000 Professional/XP and Mac compatible

### EDIROL UM-2EX

#EDUM2EX  
**\$49<sup>00</sup>**

The UM-2EX is a basic 1 MIDI in, 2 MIDI out USB interface that includes a variety of features, including FPT (Fast Processing Technology of MIDI transmission), MIDI signal indicators, and support for OS-Standard drivers on the latest versions of Mac OS and Windows.



- (1) MIDI in, (2) MIDI outs
- USB bus-powered, adapter free
- Windows and Mac compatible



**DIGIDESIGN**

**Mbox 2**

#DIMB2  
**\$449<sup>00</sup>**



The Mbox2 is a portable cross-platform USB audio interface bundled with Pro Tools LE software. It features a wide range of connection options, including analog, digital, and MIDI I/O. Never has compatibility with the worldwide DAW standard Pro Tools been so easy and cost effective.

- 32 tracks of 24-bit/48kHz audio
- (2) XLR Mic inputs featuring mic preamps w/48V phantom power & (2) 1/4" DI inputs
- (2) 1/4" line Inputs & (2) 1/4" main outputs
- Coaxial S/PDIF I/O
- (1) MIDI input, (1) MIDI output
- Zero latency monitoring with built-in headphone amp
- Includes the Pro Tools Ignition Pack( featuring powerful plug-ins, applications and software tools)
- 100% USB-powered
- Windows XP and Mac OS X compatible

**M-AUDIO**

**Fast Track Pro**

#MAFTP  
**\$199<sup>00</sup>**



The Fast Track Pro is a 24-bit/96kHz, portable USB audio/MIDI interface bundled with GT Player Express and Abelton Live Lite 4 software. This bus-powered 4x4 interface is equipped with dual mic/instrument preamps, headphone A/B source switch for DJ-style cueing, MIDI I/O and coaxial S/PDIF digital I/O with 2-channel PCM.

- Ideal mobile interface for guitarist and songwriters
- (2) mic/instrument preamps with XLR/combo jacks
- (2) 1/4" TRS outputs, (4) RCA outputs
- (2) 1/4" TRS inserts • Input/Playback mix control for hardware direct monitoring
- S/PDIF digital I/O with w/ 2-channel PCM
- Includes: GT Player Express and Abelton Live Lite 4 software • Windows XP and Mac OS X compatible

**Fast Track USB #MAFTQ .....\$99.95**

**EDIROL**

**UA-101**

#EDUA101  
**\$499<sup>00</sup>**



The UA-101 is a 10 input/10 output 24-bit/96kHz USB 2.0 audio interface designed for both portable and project studio applications. It is equipped with two microphone preamps with phantom power, six 1/4" TRS inputs, eight 1/4" TRS outputs, MIDI I/O, a built-in Limiter and S/PDIF optical inputs and outputs. This powerful interface offers incredibly low latency through both WDM and ASIO 2.0 support.

- 10x10 high-speed USB 2.0 interface
- (2) XLR/TRS combo jacks
- (6) 1/4" TRS inputs and (8) 1/4" TRS outputs
- Optical S/PDIF & MIDI I/O
- Dedicated monitor output
- 40-bit internal processing
- Includes: powerful signal router/mixer software application
- Windows XP and Mac OS X compatible

**M-AUDIO**

**Mobile Pre**

#MAMP  
**\$149<sup>00</sup>**



- 16-bit/48kHz Analog I/O
- Zero-latency direct monitoring
- Built-in headphone amp with level control
- USB-powered for total mobility
- Includes Maximum Audio Tools software bundle
- Compatible with Pro Tools M-Powered software
- Mac and Windows compatible

Mobile Pre is a bus powered 2x2 audio interface and preamp perfect for laptop recording. Its flexible Inputs and outputs include two onboard Mic preamps and high-impedance instrument inputs, ideal for connecting Guitars, Bass, and Keyboards.

**NATIVE INSTRUMENTS**

**Audio Control 1**

#NAAK1  
**\$249<sup>00</sup>**



The Audio Control 1 is a perfectly adaptable interface for musicians, producers and DJ's. This unique 24-bit/192kHz USB audio interface and controller combines 2 balanced inputs, 4 balanced outputs and freely-assignable top-panel buttons and knob, allowing advanced MIDI and key command functionality and control. Preset controller files are included along with full versions of Xpress Keyboards, Guitar Combos and Traktor 3 LE.

- 2-in/4-out, 24-bit/192kHz USB interface
- (3) assignable top-panel buttons and controller knob
- Low-latency ASIO/Core Audio drivers
- Headphone output with A/B source switching and level control
- Windows XP and Mac OS X compatible

**DIGIDESIGN****Mbox 2 Mini**

The Mbox2 Mini is an ultra-portable USB audio interface and the most affordable option available for recording with the included Pro Tools LE software. The Mini is designed for simplicity and ease of use, and an instructional DVD is included to help beginners get up and running. It features an XLR input with phantom power for pristine microphone recording and 1/4" inputs for guitars and keyboards.



#DIMB2M  
**\$295<sup>00</sup>**

- (1) XLR Mic input with preamp and 48V phantom power & (2) 1/4" DI inputs
- (2) 1/4" main monitor outputs and (1) 1/4" headphone output with (1) volume control
- 32 tracks of 24-bit/48kHz audio
- Zero latency monitoring knob with main output mute button
- Includes the Pro Tools Ignition Pack (Ableton Live Lite, Reason Adapted, and more)
- 100% USB powered • Windows and Mac compatible

**EDIROL****UA-25**

#EDUA25  
**\$239<sup>00</sup>**

- (2) high-quality, high-grade mic preamps with phantom power
- (2) Neutrix XLR/TRS Combo jack inputs, Hi-Z port for guitar • USB bus-powered
- Zero Latency, Direct Monitoring
- Built-in analog limiter
- Front panel headphone output with volume control
- Windows and Mac compatible

The UA-25 is a high-quality 24-bit/96kHz USB Audio/MIDI interface designed for computer recording in the field. It features two microphone preamps with Neutrix XLR/TRS combo connectors, MIDI I/O, and S/PDIF optical I/O. The high-grade aluminum chassis stands up to the rugged conditions associated with location recording and is an excellent shield against high-frequency interference.

**SOUND DEVICES****USBPre**

The USBPre is a bus-powered 24-bit USB audio interface with two high quality mic preamps (with phantom power), instrument/balanced-line/tape level inputs, and digital I/O. Its top-quality hardware components, compact design and extremely durable construction



#SOUSBPRE15  
**\$549<sup>00</sup>**

make this portable interface a no-compromise solution for digital recording in the field.

- Input type is selected per channel, allowing two different signal types simultaneously
- "Mix" control allows zero-delay monitoring or mix of both source and computer audio
  - High-power headphone monitor with volume control • Six-segment LED peak input meter • (2) XLR/TRS inputs, (2) RCA outputs • High-strength extruded aluminum chassis
  - Mac and Windows compatible

**TASCAM****US122L**

#TAUS122L  
**\$129<sup>00</sup>**



The US122L is a compact, portable USB audio/MIDI interface capable of simultaneously recording two tracks of 24-bit/96kHz audio with zero latency. It combines 2 XLR mic inputs, 2 1/4" inputs and MIDI ins and outs. Ideal for mobile recording, the US122L draws its power from the USB bus, has an independent headphone level control and features phantom power on both its two XLR mic inputs.

- 2-channel 24-bit/96kHz audio interface
- Zero-latency hardware monitoring
- (2) XLR mic inputs w/phantom power, (2) 1/4" inputs (1 hi/low-Z switchable) • MIDI I/O • USB 2.0 and 1.1 compatible • Windows XP and Mac OS X compatible

**APOGEE****Duet**

#APD  
**\$495<sup>00</sup>**



The Duet is a highly compact, ultra-light-weight portable FireWire interface for Mac OS X. The unit sports a pair of phantom-powered mic preamps with a hot 75dB of gain and LED metering, along with dual Hi-Z instrument inputs. The unit supports multiple sample rates up to 96kHz, and serves up the legendary Apogee sound at 24-bit resolution, with simplicity and elegance.

- Portable bus-powered 2-channel FireWire 400 audio interface • 24-bit recording resolution with selectable SRC up to 96kHz • Multi-function controller knob for volume, gain and assignable MIDI functions
- Maestro control and low-latency mixing software
- (2) XLR inputs with 48V phantom power, (2) 1/4" TS instrument inputs • (2) 1/4" TS unbalanced line outputs, 1/4" headphone output
- Mac OS X, Core Audio compatibility

## M-AUDIO Fast Track Ultra

#MAFTU  
**\$349<sup>00</sup>**



The Fast Track Ultra is an 8-channel high-speed, cross-platform USB audio interface featuring 4 Octane-technology mic pres with phantom power and internal DSP. The unit provides 8 simultaneous recording channels at 24-bit/96kHz resolution. The small footprint and light weight of the device (under 2 lbs.) allow for flexible desktop or location use.

- Portable bus- or AC-powered 8-channel USB 2.0 audio interface
- 24-bit recording resolution with selectable SRC up to 96kHz
- On-board MX Core DSP mixer with effects processing and channel routing
- (4) XLR mic pres with phantom power, 20dB pads and peak indicators
- (6) 1/4" TRS balanced line inputs and outputs, MIDI I/O
- Mac OS X and Windows XP compatible

## EDIROL UA-1EX

#EDUA1EX  
**\$79<sup>00</sup>**



The UA-1EX is a tiny bus-powered 2-in/2-out USB audio interface with 24-bit/96kHz and cross-platform capability. The device is also equipped with optical SPDIF connectors, and is well-suited for use with a laptop computer as an inexpensive but high-quality MP3 playback device, or for direct recording of tapes, vinyl or CD's to disk.

- (2) RCA phono, (1) 1/8" TS phone analog inputs
- (2) RCA phono analog outputs
- TOSLINK optical digital I/O
- (1) 1/8" Headphone output
- Electret condenser microphone in
- Selectable 32, 44.1, 48 and 96kHz sampling rates
- ASIO 2.0, WDM and Core Audio compatible
- Windows XP and Mac OSX compatible

## LEXICON OMEGA

#LEOMEGA  
**\$199<sup>95</sup>**

The Omega is an AC-powered ultra-compact 8-in/4-out USB mixer and software package, designed to be a complete and inexpensive computer audio recording solution. The mixer features the programmable Pantheon reverb (a Lexicon specialty), an opto-isolated hum- and noise-free MIDI I/O, 4 simultaneous channel recording capability, and 24-bit resolution. Cubase LE software is included, offering 48 audio and 64 MIDI track capability.

- (2) XLR mic preamp inputs • (4) 1/4" TRS phone, (1) 1/4" TS phone inputs • (2) 1/4" TRS phone outputs • Coaxial SPDIF digital I/O, opto-isolated MIDI I/O • Cubase LE software with full editing, processing, and automation
- Selectable 44.1 and 48kHz sampling rates • Windows XP and Mac OSX compatible
- Programmable Pantheon reverb with 6 types, 35 presets



## ALESIS iO-2

#ALIO2  
**\$149<sup>00</sup>**



The IO-2 is an elegant little two-channel USB audio and MIDI recording device, bus-powered and 24-bit capable. The unit features a nice analog-style work surface, zero-latency monitoring and professional microphone and instrument connectivity. Cubase LE audio software is included, turning the IO-2 into a low-cost, cross-platform recording solution for desktop music production or songwriting.

- (2) XLR microphone inputs • (2) 1/4" TRS phone outputs • Coaxial SPDIF digital I/O
- MIDI In & Out • (2) 1/4" TRS phone inputs, (1) 1/4" TRS phone insert
- 1/4" Headphone out with volume control • Windows XP and Mac OSX compatible
- Switchable 48V phantom power, 4-segment metering

## EDIROL UA-4FX

#EDUA4FX  
**\$149<sup>00</sup>**

The UA-4FX is a portable bus-powered 2-channel USB audio and MIDI interface. The unit features 24-bit/96kHz capability, built-in effects processing, low-latency performance, and a phantom-powered XLR microphone input. Cakewalk's SONAR LE audio software, and Edirol's Virtual Sound Canvas plug-in are packaged with the UA-4FX, creating an inexpensive, self-contained, cross-platform audio and MIDI recording alternative.

- (1) XLR mic in with phantom power
- (2) RCA phono, (1) 1/8" TS phone, (1) 1/4" TS phone inputs
- (2) RCA phono outputs, (1) 1/4" Headphone out • MIDI In & Out
- TOSLINK optical SPDIF digital I/O • 14 on-board effects with tube mic preamp modeler
- WDM, ASIO 2.0, Core Audio Support • Windows XP and Mac OSX compatible





## TAPCO Link.USB

The Link.USB is a two-channel, bus-powered USB audio recording interface. The 24-bit/96kHz-capable unit is clean-sounding and ruggedly housed, with sturdy knobs and *metal* front handles. The unit features a pair of phantom-powered microphone preamps, with pro combo jacks for line and instrument inputs. The Link.USB is packaged with Mackie's Traktion 2 audio and MIDI software, along with a collapsible swivel-foot for desktop use.

- (2) XLR/1/4" Combo jack inputs
- (2) 1/4" TRS phone outputs
- 1/4" Headphone output
- Extended 100dB dynamic range
- Selectable 44.1, 48, 88.2 and 96kHz sample rates
- Low-latency direct monitoring
- Windows XP and Mac OSX compatible



#TALUSB  
**\$149<sup>99</sup>**

## DIGIDESIGN Mbox2 Micro



convenient volume wheel, providing you with the freedom of true editing, sequencing, and mixing mobility. This compact solution comes with Pro Tools LE software and a full suite of plug-ins.

- Ultra-small USB Pro Tools LE solution
- Size of a typical USB flash drive
- 24-bit / 48 kHz audio
- 1/8" stereo output with volume control
- Powers via USB
- Includes: Pro Tools LE, Bomb Factory & DigiRack plug-ins, and Xpand
- Windows and Mac OS X 10.4 compatible

About the size of a typical USB flash drive, Mbox 2 Micro offers high-quality 24-bit / 48 kHz sound, a 1/8 inch stereo output for headphone or speaker monitoring (no audio inputs), and a

#DIMB2MICRO  
**\$249<sup>00</sup>**

## DIGIGRAM UAX220v2

The UAX220V2 is a portable USB 1.1 stereo audio interface, suitable for laptop or desktop use. Bus-powered and plug-and-play, the unit is basically a tiny hub with an attached breakout cable, offering professional XLR connectors, a headphone cable, and a USB connector. Ultra-quiet and lightweight, cross-platform and 24-bit capable, the UAX220V2 redefines mobility.

- (2) XLR line inputs
- (2) XLR line outputs
- (1) TRS Headphone output
- Extended 104dB dynamic range
- Mono or stereo input monitoring
- Ultra-lightweight
- PC or Mac compatible, no drivers required
- 24-bit converters, selectable 32, 44.1, 48kHz sample rates



#DIUAX220V2  
**\$409<sup>00</sup>**

## LEXICON Alpha Studio



The Alpha Studio is a compact USB audio interface and desktop recording solution. The unit comes with Steinberg's Cubase LE audio/sequencing software, and the Pantheon VST reverb plug-in. The Alpha Studio box is a 4-in/2-out conduit with 2-channel recording and ample connectivity. Simple and clean-sounding, the Alpha Studio is an excellent low-cost desktop recording system.

- (1) XLR microphone input
- (2) TRS phone line inputs
- USB digital I/O
- (1) TS phone Hi-Z instrument inputs
- (2) 1/4" TRS phone, (2) RCA phono line outputs
- High-powered headphone amp
- Separate monitor mix and output level controls
- PC and Mac compatible

#LEALPHA  
**\$99<sup>95</sup>**

## M-AUDIO Transit



The Transit is a pocket-sized, bus-powered USB recording and playback device with 24-bit/96kHz capability, an ideal and low-cost laptop audio companion. The unit allows for crystalline audio transfer between a computer and DAT, CD and MiniDisc, while delivering on digital output AC-3 and DTS to compatible external decoders.

- (1) 1/8" stereo phone line/optical in
- (1) 1/8" stereo phone line out
- TOSLINK SPDIF digital output
- 24-bit converters
- Multiple sample rates to 96kHz supported
- Extended 104dB dynamic range on output
- Compact pocket size for mobility
- Windows XP and Mac OSX compatible

#MAT2496USB  
**\$79<sup>00</sup>**

## IK MULTIMEDIA StealthPlug

#IKSP  
**\$99<sup>00</sup>**



The StealthPlug enables you to easily plug any electric guitar or bass, or even an acoustic with a pick-up directly into the USB port of a computer. A bundle of powerful software is included that transforms your PC or Mac into a virtual array of amplifiers and effects, as well as a powerful multi-track recording studio and mastering suite.

- Software included: AmpliTube 2 Live, Mackie Tracktion 2.1, SampleTank 2 SE, T RackS EQ, Sonic Reality loops
- 9 foot cable
- 1/8" stereo headphone/speaker output
- Volume up/down buttons
- Input also accepts line level signals
- 16-bit, 44kHz/48kHz sampling frequency

## M-AUDIO JamLab

#MAJL  
**\$59<sup>00</sup>**

JamLab is a compact audio interface/software bundle designed for guitar players on the go. The interface connects to your computer via USB, and is equipped with a 1/4" input for your guitar and 1/8" headphone/line output. It includes GT Player Express software, a full-featured amp simulator and virtual effects box that can also play standard audio files, and even slow them down (perfect for learning new songs).



- 1/4" guitar input and 1/8" headphone/line output
- Built-in USB cable
- 24-bit, 44.1/48kHz audio quality
- GT Player Express software (stand-alone, ReWire or VST plug-in operation)
- Variable-speed playback of standard AAC, MP3 and WAV files
- Includes WAV drum loops from ProSessions Sound and Loops Library
- Windows XP and Mac OS X compatible

## PRESONUS Firebox

#PRFB  
**\$299<sup>95</sup>**

Featuring dual low-noise mic preamps, 2 balanced TRS 1/4" inputs, and S/PDIF digital I/O, the Firebox is a complete, palm-sized professional 24-bit/96kHz FireWire audio interface for computer-based studios. Combining Cubase LE production software and a bus-powered interface, this cross-platform system provides a convenient all-in-one recording solution for both mobile and studio production.



- Very low-latency monitoring
- Cubase LE and DSP routing mixer software included
- Record/playback (6) inputs (10) outputs at 24-bit/96kHz
- Front-panel headphone monitoring and mic pre's with built-in 48V phantom power
- Plug-n-play FireWire (IEEE 1394) audio interface
- 24-bit/44.1, 48, 88.2, 96kHz sample rates supported

## EDIROL FA-66

#EDFA66  
**\$279<sup>00</sup>**



The FA-66 is a professional six input/six output 24-bit/96kHz portable FireWire audio interface designed for mobile recording. Simultaneous I/O performance is determined by the sampling rate used; 96kHz

allows for 6-In/6-Out, while 192kHz allows for 4-In/4-Out. This FireWire bus-powered interface provides a variety of input and output options, MIDI I/O, and a compact solid metal design, making it a great solution for high-resolution location recording.

- Simultaneous Performance: (6) in (6) out at 24-bit/96kHz, (4) in (4) out at 24-bit/192kHz
- (2) XLR/TRS Combo Jacks with Premium Phantom Power Mic Preamps
- S/PDIF Optical Input and Output Ports with "SYNC" LED Indicator
- Zero-Latency, Direct Monitoring
- Built-in Analog Limiter
- Windows and Mac compatible

## M-AUDIO FireWire Solo

#MAFWS  
**\$199<sup>00</sup>**

The FireWire Solo is compact bus-powered 24-bit/96kHz portable audio interface equipped with



microphone, guitar, and line inputs, coaxial S/PDIF I/O, and a stereo headphone amp. Ideal for songwriters and guitarist, the easy-to-use FireWire Solo is ASIO2, WDM, GSIF2, MME, and Core Audio compatible, and is small enough to go anywhere you want to take your music.

- XLR Microphone input with 48V phantom power, gain control, clip LED
- 1/4" guitar input with gain control and clip LED
- (2) 1/4" line inputs and (2) 1/4" TRS line outputs
- Coaxial S/PDIF digital I/O with 2-channel PCM
- Rack mountable metal chassis
- Dual FireWire ports with bus-power
- Compatible with Pro Tools M-Powered software
- Windows and Mac compatible

**DIGIDESIGN**

**Mbox 2 Pro**

#DIMB2P  
**\$699<sup>00</sup>**

The Mbox 2 Pro is a mobile high-definition 24/94k FireWire audio production system featuring a wide variety of connections,



industry-standard Pro Tools LE software, over 50 effects and instrument plug-ins, and the powerful multi-track recording and mixing capabilities you've come to expect from Pro Tools. Vocals, keyboards and guitars can be simultaneously recorded and monitored with dedicated outputs and low-latency monitoring.

- 24-bit/96kHz FireWire audio interface with Pro Tools LE software
- 32 simultaneous audio tracks with 256 MIDI tracks
- Over 50 processing plug-ins and instruments included
- Unique Beat Detective LE automatic groove analysis and correction tool
- (2) XLR/1/4" combo jacks, (2) 1/4" TRS jacks (6) 1/4" outputs
- Windows XP and Mac OS X compatible

**MOTU**

**UltraLite**

#MAUL  
**\$549<sup>00</sup>**



The UltraLite is a 10 input/14 output, 24-bit/96kHz FireWire audio interface ideal for mobile recording applications. This high-quality, bus-powered unit is equipped with 2 mic/instrument inputs with preamps (on XLR/TRS combo jacks), 6 line-level 1/4" TRS inputs, 10 1/4" TRS outputs, S/PDIF digital I/O, MIDI I/O and a dedicated stereo headphone output.

- Bus-powered, mobile FireWire interface
- (2) mic/instrument preamps with 48V phantom power
- Front-panel gain control & 3-way pad switch
- (6) 1/4" TRS inputs, (10) 1/4" TRS outputs • Dedicated stereo headphone output with level control • Coaxial S/PDIF digital I/O • CueMix DSP latency-free monitoring system
- Includes AudioDesk software (Mac OS X only) • MIDI input and output
- Windows and Mac compatible

**ECHO**

**AudioFire 8**

#ECAF8  
**\$499<sup>00</sup>**

The AudioFire8 is a high-quality FireWire interface featuring comprehensive analog and digital I/O and an intuitive software console for monitoring, metering, and setting levels. Ideal for most any studio or mobile production, the AudioFire8 provides 10 simultaneous I/O channels of pristine audio over a wide dynamic range, all at 24-bit/96kHz.



simultaneous I/O channels of pristine audio over a wide dynamic range, all at 24-bit/96kHz.

- High-quality, low-latency FireWire audio interface
- 10-channel simultaneous I/O at 24-bit/96kHz
- On-board 32-bit DSP for digital mixing and monitoring
- Inputs: (6) balanced TRS 1/4", (2) Neutrik Universal, S/PDIF (RCA), WordClock
- Outputs: (8) balanced TRS 1/4", S/PDIF (RCA), WordClock, Phones
- XP and Mac OS X compatible, includes Traktion V.1 production software

**ECAF12** 12-channel 196kHz version #ECAF12.....**\$699.00**

**M-AUDIO**

**FireWire 410**

#MAFW410  
**\$299<sup>00</sup>**



FireWire 410 is a 4x10 FireWire audio interface that includes 2 high-quality microphone preamps, MIDI I/O and multiple output options. The compact FireWire 410 can be completely Bus-powered for total mobile operation, delivering a powerful and flexible solution for the traveling musician.

- 2x8 24-bit/96kHz Analog I/O with 192kHz stereo out
- Coaxial/Optical S/PDIF I/O
- Ultra-low latency software monitoring, Near-zero hardware direct monitoring
- (2) Headphone outputs with assignable source and individual level controls
- Powered via FireWire bus or included DC supply
- Includes Maximum Audio Tools software bundle
- Compatible with Pro Tools M-Powered software
- Mac and PC compatible

**M-AUDIO**

**FireWire 1814**

#MAFW1814  
**\$399<sup>00</sup>**



The FireWire 1814 is a 24-bit 18 input/14 output FireWire audio interface with 2 high-quality microphone preamps, ADAT lightpipe, and MIDI I/O. This powerful interface has a flexible internal mixer for input and output routing, two individually assignable headphone outputs, and can be completely bus-powered, making it a great solution for both studio and mobile recording.

- 8x4 analog I/O (up to 192kHz on all outs)
- 8x8 ADAT Lightpipe I/O plus word clock
- (2) analog inputs have mic/instrument preamps and 192kHz sample rate
- Coaxial/optical S/PDIF with PCM, AC-3 and DTS
- 1x1 MIDI I/O
- Compatible with Pro Tools M-Powered software
- Windows and Mac compatible



## PRESONUS FireStudio

#PRFS  
**\$699<sup>95</sup>**



The FireStudio is a pro-level, cross-platform FireWire audio interface with a total of 26 I/O's. The unit offers 24-bit recording resolution and selectable SRC up to 96kHz, and delivers the warm, transparent sound Presonus is known for. Of particular note is the internal zero-latency full-matrix mixer and JetPLL jitter-elimination technology for the Word Clock I/O, enabling flexible routing and artifact-free playback.

- High-speed Firewire audio interface with 26 simultaneous I/O's • 24-bit recording resolution with selectable SRC up to 96kHz • Zero-latency Control Console software routing, mixing and monitoring
- (8) XLR Class A mic pres with dedicated trims, selectable phantom power • (8) 1/4" line inputs, MIDI I/O, 16 channels of ADAT I/O, SPDIF digital I/O
- Comprehensive Cubase LE and ProPak DVD audio software bundle
- Mac OS X and Windows XP compatible

## MACKIE Onyx 1200F

#MAO1200F  
**\$1699<sup>99</sup>**



The Onyx 1200F is a cross-platform FireWire front-end computer audio mixer/interface with stand-alone capability. The hefty rackmount chassis houses twelve pristine mic preamps, a 30-in/34-out connection matrix, built-in control room functionality such as talkback and A/B speaker switching, and 24-bit/192kHz converters. The Onyx 1200F offers professional studio-grade headroom, sonic clarity, and versatility virtually unmatched at its price point.

- 12 Onyx XLR microphone preamps
- (8) TRS phone line outputs
- (4) Headphone outputs
- (2) MIDI I/O, Word Clock
- Stereo AES/EBU, SPDIF I/O
- 24-bit converters, selectable SRC to 192kHz
- Matrix Mixer DSP with instant routing, level, pan recall
- Includes Traktion 2 and Final Mix software

## MOTU 8pre

#MA8PRE  
**\$549<sup>00</sup>**



The 8Pre is a professional 16-in/12-out Firewire interface with 8 microphone/instrument preamps, 8 channels of ADAT optical I/O, a built-in SMPTE reader/generator, and full 24-bit/96kHz resolution. The unit includes AudioDesk, a sample-accurate software solution for the Mac with complete tracking, editing, mixing, and real-time effects-processing. The 8Pre is loaded with pro features for a very reasonable price.

- (8) XLR/1/4" TRS Combo mic/line ins • (2) ADAT Lightpipe digital ins and outs
- Multiple monitoring mixes via CueMix DSP • (2) 1/4" TRS phone main, (1) TRS headphone out
- 48V phantom, 20db pad and trim per preamp channel
- Cross-platform with ASIO, WDM, Core Audio drivers
- SMPTE I/O, 16-channel MIDI I/O • 24-bit converter with selectable SRC

## T.C. ELECTRONIC Konnekt 24D

#TCK24D  
**\$499<sup>00</sup>**



The Konnekt 24D is a compact, cross-platform FireWire bus-powered audio interface and desktop music production

solution with built-in effects processing. The unit is equipped with dual phantom-powered microphone preamps, Hi-Z instrument inputs and Cubase LE audio and sequencing software. With stand-alone effects processor capability as well, the Konnekt 24D is a good value for both live performing and studio recording.

- (2) XLR/1/4" Combo mic/instrument inputs • (4) 1/4" TRS phone line inputs
- Dual headphone outs, direct monitoring • DSP with total recall of mixer/effects settings, routing • (4) 1/4" TRS phone line outputs • MIDI I/O, SPDIF sync I/O
- (2) ADAT /Optical SPDIF, (2) RCA SPDIF I/O's • Real-time Fabrik reverb and channel strip

## FOCUSRITE SAFFIRE PRO 26 I/O

#FOSP26IO  
**\$699<sup>99</sup>**



The Saffire PRO 26 i/o is a bus-powered, 1RU FireWire interface with 8 microphone preamps and 24-bit/192kHz resolution. The cross-platform unit features 16-channel ADAT interfacing, dual headphone outputs, and monitor control with muting and dim options. A nice set of VST and Audio unit plug-ins with EQ, compression, amp simulator, and reverb functionality is included. This interface offers pro connectivity, versatility and transparent sound.

- (8) XLR mic inputs • (8) 1/4" TRS line inputs • RCA SPDIF, BNC Word Clock, and MIDI I/O
- 2 variable impedance mic inputs • (8) TRS line outputs • (2) ADAT Lightpipe ins and outs
- 24-bit converters, selectable SRC • Desktop or mobile recording capability

**TAPCO****Link.FireWire**

The Link.FireWire is a compact 4-in/6-out, bus-powered FireWire audio interface. The sturdy little unit offers clean, uncolored sound, and is equipped with 2 high-headroom mic preamps, a headphone amplifier, 24-bit/96kHz converters, and sturdy front-panel knobs providing complete control of all level and routing requirements. Traktion 2 recording software completes the package, with tracking, processing and automation capability.

#TALFW46  
**\$199<sup>99</sup>**

- (2) XLR Combo jack mic preamp inputs • (2) 1/4" TRS phone line outputs
- (2) 1/4" TRS phone line outputs • 24-bit recording with selectable sample rates
- Coaxial SPDIF digital I/O • Headphone amplifier with level control
- Zero-latency monitoring • PC and Mac compatible

**ALESIS****iO-14**

The iO-14 is a cross-platform desktop Firewire audio interface and mixer. This bus-powered unit offers a clean, high-tech appearance and flashy LED metering. The iO-14 records at up to 24-bit/192kHz resolution, and is equipped with dual 48V mic preamps, switchable Hi-Z instrument ins, 8-channel ADAT and 2-channel SPDIF connectivity. The unit includes Cubase LE recording software.

#ALIO14  
**\$299<sup>00</sup>**

- (4) XLR/1/4" Combo mic preamp inputs • (2) 1/4" TRS instrument input
- (4) 1/4" TRS line inserts • (2) 1/4" TRS line outputs, (2) TRS Headphone outs
- MIDI I/O, 8-channel ADAT I/O, 2-channel coaxial SPDIF • 24-bit converters, SRC to 192kHz
- Ergonomic control surface

**MACKIE****ONYX Satellite**

The ONYX Satellite is a unique 2-piece Firewire audio interface and control surface. The unit consists of a detachable, bus-powered portable field recording Pod sporting flagship ONYX mic preamps, and an AC-powered desktop Base docking station replete with additional I/O's and control room functionality. This versatile recording alternative offers 24-bit/96kHz resolution and ample pro connectivity in a rugged, compact frame.

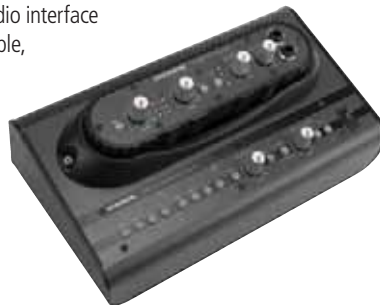
#MAOSATELLITE  
**\$199<sup>00</sup>**

- (2) XLR/1/4" Combo mic preamp inputs (Pod) • (2) XLR microphone inputs (Base)
- (4) 1/4" TRS line, (2) Hi-Z inputs (Base) • (2) 1/4" TRS line outs (Pod), (8) TRS line outs (Base)
- 24-bit converters, SRC to 96kHz • Base talkback mic and A/B monitoring
- Cross-platform Traktion 2 software included

**LINE 6****TonePort UX2**#LITPUX2  
**\$199<sup>99</sup>**

The TonePort UX2 is a USB computer audio interface that comes with GearBox software. You can process guitars, basses, and vocals in real time with effects and amplifier modeling. With two microphone and instrument inputs and preamps you can create studio-grade recordings with up to 24-bit 96kHz resolution. With low latency ToneDirect monitoring and two analog VU meters, you'll have all the tools to make the music of your dreams.

- GearBox software included with 16 models of amplifiers
- 29 stompbox and studio effects, 24 different speaker cab models
- 5 bass amp and cab models
- (2) XLR mic inputs with phantom power
- (2) 1/4" instrument inputs
- Effects like distortion, reverb, modulations, delays
- PC & Mac compatible, Ableton Live software included

**FOCUSRITE****Saffire**

The Saffire is a desktop FireWire audio interface featuring 24-bit/192kHz converters, dual phantom-powered mic preamps, and a bundled suite of effects plug-ins, powered by the unit. The 4-in/10-out box offers analog and digital connectivity, and the plug-ins, which include EQ, compression, amp-modeling and reverb, will run within the user's software platform of choice, allowing for five separate stereo mixes.

#FOS  
**\$299<sup>99</sup>**

- (2) XLR mic inputs • (2) 1/4" TRS line inputs
- (8) 1/4" TRS line outputs, Headphone out
- Separate monitor and headphone mixes
- RCA coaxial SPDIF digital I/O
- MIDI and SPDIF sync I/O • 7.1 Surround monitoring
- 24-bit converters, SRC to 192kHz

## MOTU 828 MK3

#MA828MK3  
**\$749<sup>95</sup>**



828 MK3 is a high-resolution, cross-platform, 20 input, 24-bit/96kHz FireWire Audio Interface. It is equipped with two Mic pre-amps with switchable phantom power and front panel trims, ADAT lightpipe I/O and "CueMix DSP", MOTU's on-board mixing and monitoring matrix.

- (8) 1/4" TRS analog inputs & outputs (+4/-10)
- CueMix DSP eliminates the need for external mixer or patchbay
- Word Clock, SMPTE, MIDI In and Out and ADAT Sync
- Also operates as a stand-alone mixer, no computer required
- Internal switching Power supply
- Includes drivers for Mac and PC
- Includes AudioDesk Workstation software for Mac OS

## MOTU 896HD

#MA896HD  
**\$995<sup>00</sup>**



The 896HD is a high-resolution 24-bit/192kHz FireWire audio interface that provides eight Mic preamps, 8 channels of ADAT I/O, and stereo AES/EBU. The CueMix DSP on-board mixing feature (a flexible DSP-driven 18-input/8-bus mixing and monitoring matrix) eliminates the need for an external mixer or patchbay. The versatile 896HD can be used as a stand-alone mixer and is equally well suited for both studio and stage, with or without a computer.

- (8) XLR mic pre-amps/line inputs with switchable 48V phantom power and front-panel trim controls
- (10) balanced XLR outputs
- ADAT Optical and AES/EBU digital I/O
- CueMix DSP latency-free monitoring system
- Includes AudioDesk workstation software (Mac OS only) • Windows and Mac compatible

## APOGEE Ensemble

Ensemble is a digitally controlled, professional FireWire audio interface designed specifically for the Macintosh and any CoreAudio software

applications. It is equipped with 8 channels of 24-bit/192kHz Apogee A/D and D/A conversion, four mic preamps, ADAT I/O, Word Clock I/O and coaxial & optical S/PDIF. This high-definition interface also features Precision digital encoders and Apogee's exclusive "SoftLimit", "UV22HR", and "Intellclock" technologies.

- 36 channels of simultaneous audio
- (8) channels of premium 24-bit/192K AD/DA conversion
- (4) XLR mic preamps w/inserts, (4) Hi-Z instrument inputs • (8) 1/4" TRS outputs
- ADAT, Word Clock and coaxial and optical S/PDIF I/O • (2) high level headphone outputs
- Complete integration and control with Apple's Logic Pro Software
- Compatible with OS X Core Audio (no driver required)

#APE  
**\$1950<sup>00</sup>**

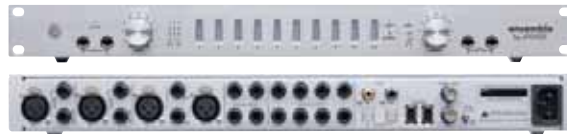

#MATRAVELER  
**\$849<sup>95</sup>**

## MOTU Traveler

The Traveler is a professional mobile 24-bit/192kHz FireWire audio interface equipped with 4 mic/instrument pre-amps, AES/EBU, S/PDIF, and ADAT optical I/O. Small enough to fit in a computer bag or briefcase, the Traveler can be powered via the FireWire bus, industry-standard battery pack or a unique 4-pin XLR power socket feature, giving users a complete battery-operated 20 input/22 output remote studio.



- Built-in SMPTE synchronization and SMPTE Console software
- Stand-alone operation for mixing and monitoring without a computer
- (8) balanced/unbalanced analog ins/outs
- Word Clock I/O, MIDI I/O, ADAT sync
- DC power jack accepts any 10-24V DC power supply
- Includes AudioDesk recording/editing/mixing software (Mac OS only) • Mac and Windows compatible

## RME Fireface 800

Featuring unique innovations like "SteadyClock" sync and "TotalMix"

DSP-based mixing and routing, Fireface

800 is a high-performance 56-channel, 24-bit/192kHz

FireWire audio interface that combines RME's latest digital converters with today's fastest FireWire protocol. All of the inputs and outputs of this high-speed workhorse can be used at the same time, and all settings including "TotalMix" are saved to an internal flash memory, with or without a computer.

- (4) Discrete, high-headroom XLR mic preamps, Hi-Z instrument input with "Soft-limiter"
- (8) 1/4" TRS inputs/outputs, (1) 1/4" TS input • (2) ADAT or S/PDIF optical I/O, coaxial S/PDIF I/O (AES/EBU compatible) • Word Clock I/O, MIDI I/O • Low-Jitter "SteadyClock" acts as sync reference for whole studio • Expansion slot for "Time Code Option" for synchronizing to LTC • Windows 2000 SP4, Windows XP and Mac OS X (10.3 or higher)

#RMF800  
**\$1699<sup>00</sup>**





**M-AUDIO****ProjectMix I/O**

The ProjectMix I/O is a combination control surface/FireWire audio interface that makes an ideal hardware complement to popular DAW applications. The interface is equipped with 8 analog mic/line inputs and 4 analog outputs, ADAT Lightpipe I/O, MIDI I/O and Word Clock I/O. The intuitive control surface is comprised of eight touch-sensitive motorized channel faders and one master fader, eight assignable rotary encoders, a jog/shuttle wheel and dedicated transport controls.

- (9) touch-sensitive motorized faders
- 18x14 FireWire audio interface
- (2) headphone outputs with independent level control
- Supports Mackie Control, Logic Control and HUI Protocols
- Dedicated keys for in/out points, locate, region nudge and loop
- Includes Abelton Live Lite 4 software
- Compatible with Pro Tools M-Powered



#MAPMIO  
**\$1249<sup>00</sup>**

**TASCAM****US-1641**

The US-1641 is a 16-in/4-out USB 2.0 audio recording interface, featuring 8 XLR mic preamps supplying phantom power and a hefty 60dB of gain. The unit offers zero-latency monitoring, a pair of configurable front-panel Hi-Z instrument inputs, and completely independent speaker and headphone monitoring outputs. The US-1641 is a worthy low-cost solution for live music or ENG location recording.

- High-speed 24-bit/96kHz USB 2.0 audio interface
- 16 simultaneous inputs, 4 simultaneous outputs
- (8) XLR mic pres and (8) TRS line inputs
- (4) TRS line outputs, headphone out
- RCA SPDIF digital I/O, MIDI I/O
- Cubase LE4 48-track audio/MIDI software supplied
- Mac OS X and Windows XP/Vista compatible

#TAUS1641  
**\$399<sup>00</sup>**

**TASCAM****FW-1884**

The FW-1884 is a professional FireWire Control Surface and Audio/MIDI Interface. It provides 18 simultaneous channels of I/O featuring 8 balanced Mic/Line inputs (with high-quality microphone preamps), 8 balanced TRS outputs, ADAT lightpipe and S/PDIF in and out.

- (8) 100mm touch-sensitive motorized Channel faders and a Master fader
- Dedicated controls for Pan, Solo, Mute, Select and 4-bands of EQ
- Zero Latency Direct monitoring
- 24-bit/96kHz A/D and D/A converters
- MIDI and Word Clock Sync in and out
- Mac and Windows compatible
- 8-channel sidecar expansion available (FE-8)



#TAFW1884  
**\$1299<sup>00</sup>**

**DIGIDESIGN****003 Rack Factory**

The Digi003 Rack is a powerful 18 channel rack-mounted FireWire audio/MIDI interface. The (4) microphone preamps and A/D conversion have been rebuilt and upgraded. New features include BNC word clock I/O, an additional headphone jack and a second set of monitor outputs to accurately monitor your work. Industry-standard Pro Tools LE production software and 80 professional plug-ins and instruments are included with the Factory system.

- (4) XLR and (4) TRS inputs, (8) TRS outputs
- Optical ADAT I/O, S/PDIF I/O
- (2) headphone outs
- Toggle between main and alternative monitors, and Aux In
- Includes Pro Tools LE software (PC and Mac) and 80 professional software plug-ins and instruments
- Includes iLok USB Smart Key
- Artist promotion services included

#DID003RF  
**\$1549<sup>00</sup>**

**DIGIDESIGN****003 Factory**

The 003 is a hands-on software control surface and 18 channel FireWire audio/MIDI interface. The control surface keeps your hands off the mouse and your head in the music. Featuring (4) improved microphone preamps and updated A/D conversion, BNC word clock I/O, and more monitoring options, plus industry-standard Pro Tools LE production software, the 003 makes a formidable production workstation.

- (4) XLR and (4) TRS inputs, (8) TRS outputs
- Optical ADAT I/O, S/PDIF I/O
- (2) headphone outs
- Toggle between main and alternative monitors, and Aux In
- Includes Pro Tools LE software (PC and Mac) and 80 professional software plug-ins and instruments
- Includes iLok USB Smart Key
- Artist promotion services included

#DID003F  
**\$2195<sup>00</sup>**

## PRESONUS INSPIRE 1394

The INSPIRE 1394 is a versatile FireWire interface equipped with four analog inputs and two ana-

log outputs. The I/O includes two microphone preamplifiers with phantom power & two instrument (Hi-Z) inputs on the front panel and stereo RCA inputs & outputs on the rear panel. It is bundled with Cubase LE software, Sony's ACID XMC, 25 effect plug-ins, and over 3GB of drum loops and samples.

- (2) XLR mic inputs, (2) 1/4" TS instrument inputs and (2) RCA line level phono inputs
- Stereo line level outputs via stereo RCA connector/ 1/8" TRS • Stereo 1/8" TRS headphone output
- Full digital control and recall from the control panel
- Low Latency hardware mixer configured from the control panel • Sync indicator LED
- (2) IEEE1394 (FireWire) ports
- Windows XP and Mac compatible



#PRI1394  
**\$149<sup>95</sup>**

## DIGIGRAM VX222v2



The VX222v2 is a high-quality digital audio interface that connects to a computer through PCI and PCI-X slots. D-Sub cables attach to the card and give you the option of stereo AES/EBU, S/PDIF, or analog line inputs and outputs. It's compatible with both Windows and Mac computers, as well as Linux ALSA. It features a dedicated Wave mixer as well as an ASIO and Mac control panel.

- PCI-X compatible • Stereo balanced line inputs
- AES/EBU digital I/O can also be used as S/PDIF
- Headphone output
- 24 bit, 8 to 50kHz sampling rates
- Windows 2000, XP, Mac OSX, and Linux compatible

#DIVX222V2  
**\$523<sup>00</sup>**

## M-AUDIO Audiophile 192

The Audiophile 192 is a high-definition 24-bit/192kHz PCI audio interface that provides rock-solid drivers and seamless integration with your favorite Mac and PC applications. It features two 1/4" TRS inputs & outputs, coaxial S/PDIF digital I/O (with 2-channel PCM) and 16-channel MIDI I/O, all supplied on a breakout cable. PCI 2.2 compliance & 64-bit audio drivers enable the Audiophile to take advantage of next-generation platforms and software.

- 1/4" TRS analog inputs & outputs • Coaxial S/PDIF digital & MIDI I/O
- Direct hardware input monitoring • SCMS copy protection control
- Software routing of inputs and outputs
- Includes Ableton Live Lite 4 music production software
- Windows 2000, XP and Mac OS X compatible



#MAA192  
**\$179<sup>00</sup>**

## LYNX STUDIO TECHNOLOGY LynxTwo-B



The LynxTwo-B Model is a 24-bit/96 kHz digital audio PCI card designed for audio/video production, DVD-Audio and mastering. It provides two 24-bit balanced analog inputs and six 24-bit balanced analog outputs, SMPTE time code reader and generator with MTC conversion, composite video genlock, 24-bit AES3 or S/PDIF I/O.

- (2) XLR inputs and (6) XLR outputs on D-sub breakout cable
- D-sub breakout cable for digital input and output, sync in and out
- SMPTE time code reader and generator/composite video genlock
- Word, 256 Word, 13.5MHz or 27MHz clock sync
- Supports Dolby AC-3 and DTS on digital I/O • PCI-X compatible
- Windows and Mac compatible

#LYLTB  
**\$899<sup>00</sup>**

## M-AUDIO Delta 66

The Delta 66 is a six input/six output 24-bit/96kHz full-duplex audio interface that connects via the Delta Series PCI host card. The breakout box is equipped with four 1/4" TRS analog inputs/outputs, and the PCI host card provides coaxial S/PDIF I/O. Dedicated control panel software enables software-driven routing for all analog and digital I/O and SCMS (Serial Copy Management System) output control.

- 4x4 1/4" TRS analog I/O
- Coaxial S/PDIF I/O with SCMS control
- Zero-latency monitoring
- AC-3 and DTS surround support via digital I/O
- Includes Ableton Live Lite 4 music production software
- Compatible with Pro Tools M-Powered software
- Windows 98SE/Me/2000 and Mac OS X compatible



#MAD66  
**\$189<sup>00</sup>**

**Delta 44** same as Delta 66, but without coaxial S/PDIF #MAD44.....**\$148.95**

## MOTU HD192

The HD192 is a PCI-based audio interface with exceptional digital converters. 12 professional-grade XLR inputs and outputs adorn the back panel, with a 19-segment LED meter on the front for every input and output. Word clock inputs and outputs allow the HD192 to act as the master clock, or sync to another. You can record at 192 kHz while synced or digitally connected to devices of various sampling rates.

- (12) balanced XLR channels with 192-kHz 24-bit capability
- 19-segment LED meter-bridge for each input and output
- Wordclock and AES/EBU input and output
- I/O can support two simultaneous 5.1 mixes
- Connect up 4 audio interfaces to the included PCI-42 Card
- Standard PCI Mac and PC compatible

**HD192PCIE** Same as HD192 with a PCIe compatible card #MAHD192PCIE.....**\$1699.95**

**HD192E** Expansion HD192 unit (no PCI-424 Card) #MAHD192E.....**\$1514.95**



#MAHD192  
**\$1799<sup>00</sup>**

## APOGEE Symphony Bundle



The Symphony PCI Express bundle connects any combination of Apogee's renowned Rosetta or X-series converters seamlessly with Apple's Mac Pro computer. This gives you 32 channels of I/O, with the option of using up to 3 cards (192 channels). It's a powerful and elegant-sounding hardware companion to Logic Pro, with ultra-low latency and the DSP capacity to run hundreds of plug-ins.

- 1.6 milliseconds of latency at 96kHz
- 32 channels of I/O per card
- Unparalleled DSP processing capacity
- Includes Maestro software interface
- Includes X-Symphony card and Symphony PCI Express card
- Compatible with Rosetta 200 & 800, AD-16X & DA-16X
- Compatible with any CoreAudio application (DP, Cubase, etc.)

**Symphony** PCI-X version for G5 tower #APSXB .....**\$1079.95**

## M-AUDIO Delta 1010LT

The Delta 1010LT is a 10 input/10 PCI audio interface with two color-coded breakout cables. Connectivity includes: two mic/line preamps on XLR connectors, six RCA inputs, eight RCA outputs, MIDI I/O, Word Clock I/O and coaxial S/PDIF I/O. Up to four Deltas can be combined in your system for a maximum of 32 analog and four stereo S/PDIF inputs and outputs.

- (2) XLR mic preamps
- (8) RCA inputs and (6) RCA outputs
- Compact, half-size PCI card
- MIDI & Word Clock I/O
- S/PDIF digital I/O with PCM and AC-3/DTS surround
- Software controlled 36-bit internal DSP digital mixing/routing
- Includes Ableton Live Lite 4 music production software
- Windows and Mac OS X compatible

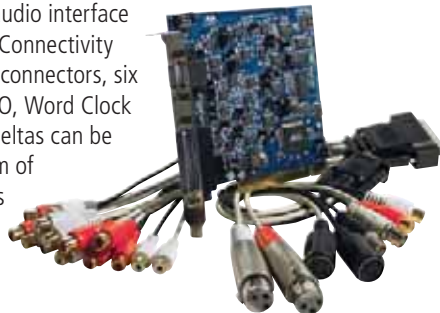

#MAD1010LT  
**\$199<sup>00</sup>**

## ECHO Mia MIDI

The MiaMIDI is full featured 24-bit/96kHz PCI audio card with a pair of balanced 1/4" analog inputs and outputs with a breakout cable for coaxial S/PDIF

I/O and MIDI I/O. A unique feature of this interface is the use of "virtual" outputs. MiaMIDI appears to software as if it had eight separate outputs, which are digitally mixed down to the physical outputs using MiaMIDI's "console" software and its on-board DSP.

- (2) analog inputs and (2) analog outputs on 1/4" TRS connectors
- 24-bit coaxial S/PDIF digital I/O
- Supports full duplex 4-channel in, 4-channel out operation
- On-board 24-bit Motorola DSP for mixing and monitoring
- PCI bus mastering interface: works with PCI-X (3.3/5 volt) and Power Mac G5
- Windows and Mac compatible



#ECMM  
**\$129<sup>00</sup>**

## M-AUDIO Audiophile 2496

Featuring reliable, rock-solid operation and a simple, seamless setup, the Audiophile 2496 is an affordable all-in-one solution to high quality 24-bit/96kHz audio production.

Bundled with Maximum Audio

Tools creative music making software, the 2496 is capable of both digital and analog performance, while providing a fast throughput, low latency, and a patchbay router control panel for maximum control of the audio signal.

- 24-bit/96kHz fidelity
- 2x2 analog I/O (RCA connectors)
- S/PDIF digital I/O with 5.1 Dolby Digital support
- Compatible with Pro Tools M-Powered software
- 36-bit internal DSP mixing/routing



#MAA2496  
**\$99<sup>00</sup>**



### RME HDSP9632

#RMHDSP9632  
**\$499<sup>95</sup>**

The Hammerfall DSP 9632 is a high-resolution PCI audio card with RME's latest 192kHz A/D and D/A converters, unbalanced stereo analog inputs and outputs, ADAT lightpipe, and coaxial S/PDIF (optional balanced XLR/ AES and EBU breakout cable available). It features unique innovations like "SteadyClock" sync and "TotalMix" DSP-based mixing and routing, and can be upgraded with a variety of expansion options.

- Stereo analog in and output on RCA connectors
- ADAT digital I/O, supporting 96kHz S/MUX operation
- MIDI I/O with 16 channels of MIDI via breakout cable
- TotalMix: 512-channel mixer with 40 bit internal resolution • Windows 2000/XP and Mac OS X

Expansion Options include:

- BO9632-XLRMKH** XLR breakout cable #RMB09632XLRM..... **\$79.50**
- A04S-192** TRS output daughter card #RMA04S192..... **\$269.00**
- AI4S-192** TRS input daughter card #RMAI4S192..... **\$269.00**
- WCM** Word Clock module #RMWCMHDSP9632... **\$169.00**



### RME HDSP9652

#RMHDSP9652  
**\$699<sup>00</sup>**



The Hammerfall HDSP9652 is a 52-channel, 24 Bit/96 kHz PCI I/O card that provides DSP-based mixing and routing, low latency and flexible I/O & expansion. This high-performance

digital interface is equipped with 3 ADAT I/Os, coaxial S/PDIF I/O, Word Clock I/O, 32 channels of MIDI I/O and ADAT sync.

- 52-Channel 24 Bit/96 kHz I/O Card
- 3 x ADAT optical I/O
- 1 x SPDIF digital I/O
- TotalMix: 1352 channel mixer with 40-bit internal resolution
- Unique Zero CPU Load technology
- Word clock I/O (BNC) on included expansion board
- 32 channels high-speed MIDI via breakout cable
- Supports expansion boards
- Windows and Mac compatible

### RME

#### Multiface II/ HDSP PCI Bundle

#RMMF2PCIB  
**\$1099<sup>00</sup>**

Designed to provide the highest level of audio quality for both Mac and PC platforms, the RME Multiface II is a superior 36-channel 24-bit/96kHz I/O box that connects to a computer via the HDSP PCI host card.

It's award-winning Hammerfall technology provides "zero CPU load", extremely low latency, and their TotalMix DSP mixer, offering almost limitless intuitive routing capabilities with 40-bit internal resolution.



- 36-channel 24-bit/96kHz operation
- (8) balanced 1/4" analog I/O
- HDSP PCI card interface
- ADAT I/O with ADAT Sync, S/PDIF I/O and Word Clock
- TotalMix DSP mixer with 40-bit internal resolution
- Computer connectivity via HDSP PCI or CardBus cards (optional)
- Unique DIGICheck analysis software included

**Multiface II/ HDSP PCMCIA Cardbus Bundle** #RMMF2CBB..... **\$1149.00**

### RME

#### Digiface

#RMDF  
**\$799<sup>00</sup>**



The Digiface is a compact 52-channel 24-bit/96 kHz digital I/O interface designed to connect with RME's HDSP PCI or HDSP PCMCIA cards.

It is equipped with three ADAT optical I/Os, ADAT-Sync In, coaxial S/PDIF & Word clock I/O, MIDI I/O and a separate stereo analog line out. The Digiface's "zero CPU load" technology guarantees high performance and low latency.

- (3) ADAT digital I/O
- Word clock & coaxial SPDIF digital I/O
- TotalMix DSP based mixing and routing
- 2 x MIDI I/O, 32 channels high-speed MIDI
- 1/4" TRS line/headphone output
- Compatible with HDSP PCI & HDSP PCMCIA host cards

**HDSP PCI** PCI host card #RMHDSPPCI..... **\$299.00**

**HDSP PCMCIA** PCMCIA host card #RMHDSPPCMCIA..... **\$399.00**

### M-AUDIO

#### Delta 1010

#MAD1010  
**\$599<sup>00</sup>**

Delta 1010 is a 24-bit/96kHz full-duplex breakout-box interface that connects via the Delta Series PCI host card. Its superb engineering and high-quality converters deliver fidelity that surpasses systems costing many times more.

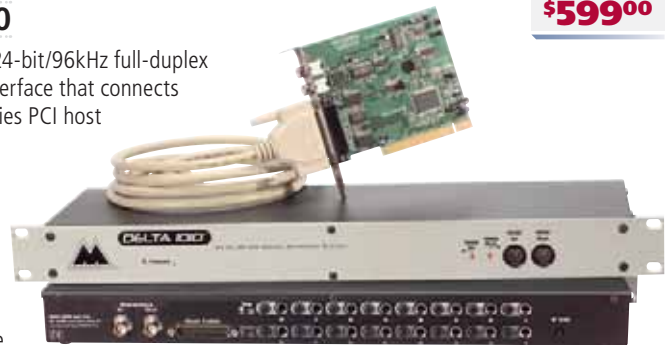

- 8x8 Analog I/O balanced/unbalanced with 1/4" TRS connectors
- Coaxial S/PDIF digital I/O
- Word Clock I/O for sample accurate sync
- 36-bit internal DSP digital mixing and routing

- Includes Maximum Audio Tools software bundles
- Compatible with Pro Tools M-Powered software
- Mac and Windows compatible

## ECHO Layla 3G

The Layla 3G is Echo's flagship 24-bit/96kHz PCI-based recording system consisting of a bus mastering PCI host card and a full-featured breakout box. Featuring two Neutrik combo inputs with mic preamps, six balanced inputs/eight balanced outputs, ADAT lightpipe I/O, optical/coaxial S/PDIF and MIDI I/O, the Layla 3G is a high-performance choice for today's professional computer recording studio.

- (2) auto-sensing Neutrik combo inputs (mic/guitar/line)
- 48V phantom power on XLR inputs
- (6) balanced analog inputs (8) balanced analog outputs on 1/4" TRS connectors
- Headphone output with level control
- Includes "Traktion" professional recording and MIDI production software
- Word Clock Sync I/O
- Mac and Windows compatible



#ECL3G  
**\$499<sup>00</sup>**

## MOTU 2408MK3



The 2408 is a rack-mounted, 24-bit/96kHz audio interface equipped with 8 1/4" TRS analog inputs/outputs, 24 channels of ADAT

optical & TDIF I/O, S/PDIF I/O, ADAT sync and SMPTE/Word Clock in and out. The included PCI-24 card is used to connect this versatile interface to computer audio workstations and provides the DSP horsepower for creating custom tailored monitor mixes of up to 96 channels of 96 kHz audio.

- (8) 1/4" TRS analog inputs & outputs
- 24 channels of ADAT optical input/output
- 24 channels of TDIF input/output
- 2 channels of S/PDIF in and 4 channels out
- Includes cross-platform PCI-424 card and AudioDesk software (Mac OS X only)
- Windows XP and Mac compatible

#MA2408MK3  
**\$945<sup>00</sup>**

## MOTU 24I/O

The 24I/O is a high-quality, rack mount 24-bit/96kHz audio interface that provides 24 1/4" TRS

analog input and outputs and attaches to a computer workstation via the included PCI-24 audio card. The PCI-24 features a powerful DSP chip dedicated to creating custom tailored monitor mixes, and has ports for up to four interfaces; allowing you to mix and match MOTU audio interfaces to meet your exact I/O needs.

- (24) analog inputs and outputs on balanced/unbalanced 1/4" TRS connectors
- 16-, 20-, and 24-bit recording at 44.1, 48, 88.2 and 96kHz
- Word Clock sync
- PCI-24 100% compatible with all MOTU Audio Wire interfaces
- Includes AudioDesk workstation software (Mac OS only)
- Windows and Mac compatible



#MA24I/O  
**\$1495<sup>00</sup>**

\*Also available as an expansion unit w/o PCI-24 card #MA24IOE

## ECHO Indigo DJ

The Indigo DJ is a dual stereo, 24-bit cardbus audio card designed for portable digital DJ applications. It offers two independent stereo 1/8" analog outputs; one for setting up your cue mix on a pair of headphones, and the other for the house mix (with analog volume knob to control headphone output).



#ECID  
**\$199<sup>00</sup>**

- (2) independent stereo 1/8" analog outputs
- Preview cue mix on the headphone output while playing back house mix on the line output
- Supports true 24-bit/96kHz audio
- Software console for metering and setting levels
- Type II Cardbus slot required
- Includes 6-foot adapter cable for RCA and 1/4" connections
- Windows Me/2000/XP and Mac OS X compatible

## E-MU 1616M



#EM1616M  
**\$499<sup>99</sup>**

The E-MU 1616M is a mastering grade, laptop digital audio system comprised of the portable MicroDock M breakout box, the E-MU CardBus card and E-MU production tools software bundle. This 16 input/output system provides two XLR mic preamps, four 1/4" TRS Inputs, six 1/4" TRS outputs, ADAT I/O, S/PDIF output, turntable input, stereo 1/8" speaker outputs and two Headphone/Line Outputs.

- Mastering grade 24-bit/192kHz converters
- (2) Mic/Line/Hi-Z Preamps w/ Soft Limiter and 48V phantom
- S/PDIF Out (switchable to AES/EBU)
- Turntable input w/ground lug and hardware RIAA preamp
- Hardware-accelerated effects processor with over 28 effects plug-ins
- Includes E-MU Production Tools Software Bundle
- Windows 2000 & XP compatible



## NATIVE INSTRUMENTS

### Traktor DJ Studio 3.0

#NATDJ3  
**\$199<sup>00</sup>**

Traktor 3.0 DJ Studio is the leading-edge software solution for professional DJ mixing and recording using the .MP3, .WAV, .AIFF and audio CD file formats. With advanced features that only software can provide, Traktor 3.0 goes far beyond the possibilities of conventional DJ gear, allowing almost infinite creative possibilities.

- Two scratchable playback decks with  $\pm 100\%$  pitch control and 2-channel cue section
- Records mixes as non-destructive automation file
- High-quality time stretching and pitch shifting
- Powerful database with Quick Search, capable of processing 1000's of tracks instantly
- +12dB/-24dB 3 band EQ, 8-pole resonant filters and kill switches for each deck
- Windows 2000/XP and Mac OS X 10.3.9 or higher



## BIAS

### Peak Pro 5

#BIPP5  
**\$499<sup>00</sup>**

Peak Pro 5 is the professional standard for stereo Recording, Editing, Processing, and Mastering on Mac OS X. This complete editing suite solution now includes Roxio Jam 6, (the professional Redbook standard for CD burning) and SFX Machine LT, (a powerful multi-effects sound design plug-in). Peak Pro 5 is ideal for music production, broadcast editing, and film/video/multimedia sound design applications.

- Over 25 VST audio effects plug-ins bundled free
- Sophisticated playlist with graphic waveform view and advanced crossfade control
- High-quality DSP algorithms for Change Pitch, Change Duration and Sample-Rate Conversion
- Unlimited Undo/Redo with full edit history
- Advanced QuickTime movie and DVC clip support
- Supports built-in Mac I/O, and Core Audio compatible hardware
- 100% Redbook replication-ready CD burning with ISRC, PQ subcodes and more



## CAKEWALK

### Sonar 7

#### Producers Edition

#CAS7PE  
**\$499<sup>00</sup>**

The Windows-only based Sonar 7 Producer is a professional digital audio workstation with a variety of unique, powerful tools that allow users to compose, record, and mix their projects at the highest possible quality. Its 64-bit mix engine brings more clarity, detail, and definition to projects, accessible even on 32-bit computers. Dynamically re-map hardware controllers, improve project efficiency, multitrack audio quantize, and safeguard your work against faulty plug-ins and other crash sources via Crash Recovery. A must for the next generation of audio production.

- Truly native 64-bit DAW with unlimited audio, MIDI, plug-ins and busses
- AudioSnap—seamless audio tempo changes, convert audio to MIDI, sync multiple tracks
- Dynamically re-map effects, mix and instrument parameters to hardware controllers
- Score to video and output to 1394 FireWire devices • 31 audio and 8 MIDI effects including Roland's V-Vocal
- Completely customizable user interface

## SONY MEDIA SOFTWARE

### Acid Pro 6

#SOSAC6000  
**\$299<sup>00</sup>**

Acid Pro 6 is loop-based music composition and production application for Windows, with a host of advanced professional features and a user-friendly interface. With its straightforward "pick, paint, and play" track creation, real-time pitch and tempo matching, and groove quantization of audio and MIDI events, Acid Pro 6 is ideal for remixing, creating audio beds, and scoring digital video.

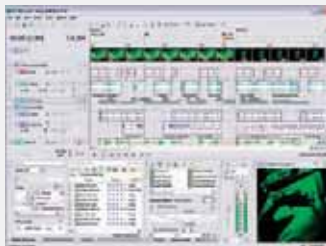

- Includes over 1000 music loops in multiple genres
- Exclusive "Media Manager Technology" to organize and search loop database
- Unlimited tracks of Audio and MIDI, 24-bit/192kHz audio support
- Over 20 real-time DirectX audio effects and VST/VSTI support
- 5.1 surround mixing support, and integrated disc-at-once CD burning
- Windows 2000 and XP compatible

## STEINBERG

### Nuendo 4

#STN4  
**\$1799<sup>99</sup>**

Nuendo 4 is Steinberg's complete "Native" Media Production System. Designed to meet the exacting demands of audio professionals working in a variety of specialized applications, including music composition, game and multimedia sound design, broadcast, and post production film/video.



- Flexible configuration allows custom user interface design
- Powerful new networking capabilities for collaborations in large-scale projects
- VST System Link- CPU intensive tasks can be allocated to various computers
- Fully Surround capability for 5.1, 7.1, and 10.2 productions (optional Dolby Digital and DTS encoders)
- Precision 32-bit floating point audio processing and Mixing
- Includes a huge array of virtual effects and instrument plug-ins
- Powerful editing engine with unlimited undo/redo and complete edit history
- Windows 2000, XP and Mac OS X 10.3 or higher compatible





## MAKEMUSIC Finale 2008

#MAMFHR08  
**\$449<sup>95</sup>**

Finale 2008 is the industry-standard music notation and publishing software for both Windows and Mac platforms. Used by educators, students, and composers worldwide, the powerful yet intuitive 2008 version features revolutionary tools for creating, evaluating and shaping ideas into the most basic songs or complex arrangements and compositions. Improvements include time-saving editing and navigation enhancements, high-end editing and spacing improvements.

- Finale Performance Assessment – innovative educational tool
- Human Playback plays your musical expressions exactly as you want
- New Studio View gives users “mixer-like” control
- Linked Parts generates and formats part automatically
- Import digital video with automatic synchronization to music
- Windows XP and Intel/Mac support



## APPLE Logic Studio - USA

#APLSU  
**\$499<sup>00</sup>**

Logic Studio USA is a complete production solution for professional desktop audio production. The bundle includes Logic Pro 8, the renowned audio and sequencing program, the large Studio Instruments plug-in collection, the Studio Effects collection of compressors, amp models, and multi-effects, the MainStage live plug-in performance interface, the Soundtrack Pro 2 audio post-production tool, and the Studio Sound Library, a huge collection of loops, sampled instruments, and channel-strip settings.

- Complete software DAW production solution
- Studio Instruments collection with 40 instrument plug-ins
- MainStage 3-D interface for live virtual instrument and plug-in performance
- Studio Effects collection of 80 effects and modeling plug-ins
- Soundtrack Pro 2 for seamless audio post-production for picture
- Studio Sound Library with 18,000 loops, 1300 sampled instruments, 2400 channel-strip settings



## M-AUDIO Pro Tools M-Powered

#MAPTMP73  
**\$249<sup>00</sup>**

Pro Tools M-Powered is a version of Digidesigns Pro Tools software designed specifically to work with select M-Audio hardware interfaces. A variety of M-Audio PCI and FireWire interfaces are compatible with Pro Tools M-Powered software including: Audiophile 2496 & 192, the Ozonic, and the FireWire 410 and 1814. Pro Tools M-Powered software provides 32 tracks of 24-bit/96kHz audio recording/editing/mixing, a fully-integrated MIDI sequencer, and session compatibility with Pro Tools-equipped studios worldwide.

- Award-winning audio recording, editing and mixing
- Session compatibility with other Pro-Tools-equipped studios
- Unique Beat Detective LE automatic groove analysis/correction tool
- Includes over 30 free RTAS and Audio Suite plug-ins
- Accepts Rewire output stream
- Windows XP and Mac OS X compatible

## SONY MEDIA SOFTWARE Sound Forge 9

with CD Architect

Sound Forge 9 is a professional software package for 24-bit/32-bit/192kHz two-track audio recording, editing, processing, and mastering on the PC platform. With extensive file format support, powerful audio effects, and support for multiple video formats, the comprehensive Sound Forge 8 Bundle enhances workflow and productivity with its ease of use and intuitive interface.



#SOSF9000  
**\$299<sup>95</sup>**

- Includes CD Architect 5.2 Red Book Audio CD authoring Software
- Includes over 40 DirectX audio plug-ins
- VST plug-in effect support
- High-quality time compression/expansion
- Support for video formats including: AVI, WMV, MPEG-1, and MPEG-2
- Low-latency ASIO driver support
- Windows 2000 or XP

## STEINBERG Wavelab 6

Wavelab 6 sets a new standard for integrated audio editing, effects processing and mastering on Windows XP and 2000. DVD Audio authoring and CD/DVD burning/archiving are both fully supported, including high-resolution stereo and surround formats. Not just a top-level mastering tool, Wavelab 6 offers powerful features for multimedia, broadcast, and multi-channel surround applications.



#STWL6  
**\$549<sup>99</sup>**

- All-in-One solution for high-resolution stereo and multi-channel editing and mastering
- Innovative “Audio Montage” user interface with unlimited UNDO/REDO
- New “Smart” video thumbnail for editing audio for video
- Support for DVD Real-time text and static text, still images, slide shows and graphic menus
- Complete Red-Book CD mastering toolkit including signal processing, track sheets and CD cover layout tools
- Real-time processing with 32-bit floating-point processing
- Audio file support up to 24-bit /192kHz



## STEINBERG

### Cubase 4

#STC4Q  
\$799<sup>99</sup>

Cubase 4 is an advanced digital audio workstation that combines excellent sound quality, intuitive control, and a vast range of highly advanced audio and MIDI tools for composition, recording, editing, and mixing. It features a powerful Control Room section, VST3 plug-in technology, the revolutionary SoundFrame-Universal Sound Manager, MediaBay database, and more. Composers and musicians will benefit from enhanced score editing, the efficient, redesigned user interface, and multiple features for adapting to individual workflow and creativity.

- 24-bit/96kHz audio workstation with unlimited tracks and plug-ins
- Control Room integration within your outboard studio environment
- Professional music notation and score printing
- Brand-new VST3 plug-in and built-in software instruments with more than 1000 sounds
- Seamless integration of external audio and MIDI hardware
- Windows XP and Mac OS X compatible



## PROPELLERHEAD

### Reason 4

#PRR4  
\$399<sup>00</sup>

Reason 4 is an infinitely expandable standalone music workstation application with a simple yet powerful interface. It features a wide variety of synthesizers, samplers, drum machines, and effects that perform just like their hardware counterparts, and includes both pattern-based and piano scroll style sequencers. Version 3.0 features the new "Combinator", allowing you to build elaborate chains of instruments, effects, and sequencers that are saved as Combi patches.

- Native Performance, no special hardware needed
- Virtual rear panel hardware patching for infinite routing possibilities
- Sound Bank 3.0 – Expanded library of synth patches, multi-sampled instruments, and Combinator patches
- "Rewire" allows routing of 64 channels of synchronized audio
- Full Automation and Recall of all parameters
- Includes MClass mastering suite effects and Orkestra sample library
- Mac and Windows compatible



## CAKEWALK

### Sonar Home Studio 6 XL

#CASH56XL  
\$159<sup>00</sup>

Home Studio 6 XL is a complete audio and MIDI production software package for Windows. With 64 audio tracks and unlimited MIDI tracks, virtual instruments (drums, bass, guitar, keys, orchestral sounds), VST and DX plug-in support, and ReWire capability, you have everything you need to create compelling music. The XL edition includes professional signal processing, sounds and instruments like the Dimension LE synth and Session Drummer 2.

- Edit and print music notation
- Video window for soundtrack scoring
- Freeze instruments and effects to save CPU power
- Includes reverb, delay, dynamics, amp simulation, and more
- Includes Cakewalk Publisher to customize a song player for MySpace
- Master with the Boost 11 limiter and burn your mix directly to CD
- Windows XP/Vista/Vista x64 (not Mac compatible)

## TASCAM

### GigaStudio 3

#TAGS30  
\$249<sup>00</sup>

GigaStudio 3 is a powerful standalone sampling workstation for the Windows platform, available in three different versions: Orchestra, Ensemble, and Solo. Rewire support allows GigaStudio instruments to appear in your workstation software, right beside your plug-in instruments and audio tracks. The efficient kernel-level processing and RAM usage results in more polyphony than any other software sampler, and allows GigaStudio to load sample files up to 512 gigabytes in length.



- Built-in digital mixer with 128 channels and 32 fader groups
- Maximum Voices: Orchestra – Unlimited, Ensemble – 160, Solo – 96
- VST plug-in hosting • 24-bit/96kHz sample support
- Includes GigaPulse SP convolution effects
- Includes comprehensive sample libraries: Orchestra – 17GB, including custom Vienna Giga Symphony, Ensemble – 11GB, and Solo – 3GB

## DIGIDESIGN

### DV Toolkit 2

#DIDVTK2  
\$1295<sup>00</sup>

The DV Toolkit 2 is a software upgrade bundle that adds post-production functionality to Digidesign Pro Tools LE systems. With the addition of frame-accurate Time Code functions, AAF/OMF import and export, and specialized plug-ins, the DV Toolkit 2 enables users to easily edit and sweeten the audio content of film and video projects.



- Timebase Rulers: spot audio to Time Code or Feet + Frames
- Up to 48 Mono or stereo tracks at up to 96kHz
- Includes DigiTranslator 2.0 for full AAF/OMF import/export
- DINR LE Intelligent noise reduction plug-in • Synchro Arts VocALign Project audio alignment plug-in • TL Space convolution reverb
- Audio/Video rate Pull Up and Pull Down
- Requires iLok USB Smart Key (not supplied)

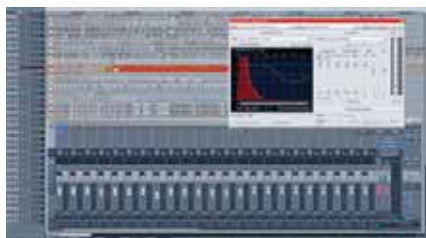

## MAGIX Samplitude 10

Professional

#MASP10  
**\$999<sup>00</sup>**

Samplitude Pro 10 is a comprehensive professional recording, mixing, editing, and mastering DAW with outstanding stability and audio quality. Few DAW's meet the complete production needs of users quite like Samplitude, with its dynamics processing, multi-effects, EQ's, multi-band compression, and enhancing, this Windows-only format provides an absolute phase stable, low latency engine that delivers superior tracking, mixing and mastering capabilities.

- Professional audio/MIDI/editor with "Red Book" CD burning
- Up to 1000 audio/MIDI tracks with unlimited plug-ins (CPU dependent)
- Automatic latency compensation throughout the whole signal path
- 24-bit/192kHz DVD production and surround burning capabilities
- Complete mixing and mastering tools provided
- VST and DirectX support



## ABLETON Live 7

#ABL7  
**\$499<sup>00</sup>**

Live 7 is the latest version of the revolutionary music production software that allows users to spontaneously compose, record, remix, improvise and edit musical ideas in a seamless audio/MIDI environment. It combines, in a single interface, loop and linear production methods with virtual instruments and effects. Added features include Movie Import, Deep Freeze editing, multi-processor support, and a comprehensive collection of instruments and project management tools.

- Unlimited 32-bit/192kHz multitrack hard disk recording
- Realtime pitch-shifting and time-stretching
- Movie Import feature includes warping sound to picture
- Comprehensive audio and MIDI recording
- Audition clips, in sync, while main mix is playing
- Windows XP and Mac OS X compatible



## CAKEWALK Project5

Version 2

#CASP5V2  
**\$199<sup>00</sup>**

Project5 is an integrated software studio environment that incorporates sequencers, software synthesizers, samplers, effects, and audio looping tools into one easy-to-use application. With powerful features like real-time pattern genesis and triggering, and its seamless live-performance audio engine, Project5 gives users all the creative tools needed to create and perform exciting electronic music tracks.

- Studio-quality instruments and effects
- Pattern-based creation tools: step sequencer, pattern editor
- Flexible looping tools with ACID-format loop support
- Advanced capabilities for synth layering, keyboard mapping, and pattern triggering
- Real-time, live performance features
- Windows 2000/XP compatible

## MOTU Digital Performer 5

#MADP5  
**\$499<sup>95</sup>**

Digital Performer 5 is MOTU's most comprehensive integrated MIDI and Audio sequencer designed for studio recording, film scoring, and remixing. Many exciting new features have been introduced including: a new Beat Detection Engine, plug-in latency compensation, the MasterWork EQ, enhanced Pro Tools support and the new "QuickScribe" view that displays cue points in a manner familiar to film composers.



- Virtual instrument track support
- 64-bit floating-point mastering tools
- Unlimited customized "Consolidated Window" layouts
- FireWire QuickTime video playback • Apple Loop, Acid, and REX import • OMF import/export • Mac OS X 10.3 or higher

**Digital Performer 5** competitive upgrade #MADP5U.... **\$319.95**

## SIBELIUS Sibelius 5

Professional

#SIS5P  
**\$449<sup>95</sup>**

Created for musicians by musicians, Sibelius 5 does it all by allowing more attention to notes and less to details. Utilizing unique composition systems applicable for both professional and beginners alike, Sibelius Pro 5 has become recognized as a sophisticated, yet creative and simple-to-use notation tool. Styles and arrangements are freely adjusted while maintaining the expressive nuances and dynamic phrasing required for an intelligent, well-executed layout.



- Outstanding teaching and learning tool in the classroom or on the Internet
- "Flexi-time" – real-time MIDI input that follows your playing
- Arrange – automatically arranges/orchestrates music
- Scanning – scans music into computer for playback and editing
- Easy-to-learn manual with extensive learning support
- 37 plug-ins included • Exceptional print quality and graphics for publishing
- Imports and converts: Finale, SCORE, Allegro, PrintMusic, Sibelius, and MIDI files





## STEINBERG Cubase Studio 4

#STCSE  
**\$199<sup>00</sup>**

Cubase Studio 4 is an affordable way to tap into the powerful audio and MIDI recording tools developed by Steinberg, such as its rich sounding 32-bit audio engine, unlimited audio and virtual instrument tracks, and 47 included plug-ins. A silence detector disengages a plug-in when no signal is present to conserve CPU. The customizable user interface has been carefully redesigned to intuitively enhance the workflow.

- Includes Roomworks reverb, Studio Chorus, and guitar amp/speaker simulators
- HALion One sampler come with Yamaha Motif series content
- Write, edit, and print musical notation and scores
- Mac and Windows compatible
- Includes Prologue analog modeling synthesizer
- Track presets and Inplace editing



## EXPANSION GURU

#FXG  
**\$249<sup>95</sup>**

GURU is an easy-to-use yet very powerful sampling beat box that includes 2GB of sample content, an advanced 128-step sequencer and manipulation effects such as Bit Crusher and Trance Gate. The intelligent loop slicer automatically categorizes and maps each of your samples, giving you manual slice-tuning capability and flexible audio output routing. Up to 8 engines can be layered at one time, giving you a complete sample workstation environment.

- Advanced step sequencer
- Automated sample slicing, classification and mapping
- Loads WAV / AIFF / Rex, MIDI Loops, Kits and more
- Flexible groove/shuffle control
- Eight stereo audio outputs
- Comprehensive pad editor



## APPLE Logic Express 8

#APLE8U  
**\$199<sup>00</sup>**

Logic Express 8 is Apple's affordable feature-packed software that provides professional audio and MIDI tools for Mac-based music production. It combines a core collection of powerful effects and virtual instrument plug-ins with slick recording, mixing, and editing capabilities. Record up to 12 different tracks at the same time, import GarageBand files and Apple loops, or re-wire your favorite stand-alone instruments, all with 32-bit processing and 24-bit/96kHz audio quality.

- Extensive MIDI and audio composition/production features
- Supports 255 stereo tracks, 64 instrument tracks, 8 buses and 4 inserts
- EXSP24 sampler w/library, 40 software instruments and 70 effect plug-ins included
- Layout and print complete professional scores
- Full ReWire integration, Audio Units, AAC and MP3 support

## MACKIE Tracktion 3

### Project Bundle

Tracktion 3 was designed to be an easy-to-use audio/MIDI recording application. All operations in the program take place on a single screen, making everything from initial composing to final mastering as painless as possible. Its new Loop Browser helps you navigate hundreds of supplied sounds to help get ideas flowing. You can even integrate Tracktion 3 with other audio software with full ReWire 2.0 support.



#MAT3P  
**\$99<sup>99</sup>**

- Supports Quicktime video playback for scoring
- Includes virtual instruments, sound sets, and effects and dynamics plug-ins
- Time stretch and pitch shifting
- Unlimited track count • Powerful MIDI editor
- Export as MP3 • Mac and Windows compatible

## MAGIX Sequoia

Sequoia is a complete recording editing and mastering suite for recording studios, broadcast facilities and post houses looking for the utmost in flexibility and solid performance. Features like full plug-in delay compensation throughout the program, quick audio CD and archival CD-ROM burning as well as separate crossfade Undo management put it in a class of its own. Full networking is supported for multiple users and plug-ins like Renovator (which removes sudden unwanted acoustical events such as coughing and car horns) are only a hint at the depth of this program.



#MAS10  
**\$299<sup>99</sup>**

- Sound cloner for copying sonic characteristics between tracks
- Folder Tracks combine several tracks into a neat visual package
- Support for all major multi-channel formats • Surround room simulator
- Burn high-definition stereo and surround audio DVDs



## BIAS

### Master Perfection Suite

The Bias Master Perfection Suite is a collection of professional mastering plug-ins for Mac and Windows that offer a lot of power to project studios on a budget. The suite includes PitchCraft (pitch correction), Reveal (analysis), SuperFreq (equalization), GateEx (gate/expander), Sqweez 3 & 5 (multi-band compression/limiter/upward expander), and Repli-Q (EQ curve matching).

#BIMPS  
**\$499<sup>00</sup>**

- Pitch correction, frequency analysis, EQ, gate/expander, compression, and EQ matching
- Save and load learned frequency spectrums with Repli-Q • 4,6,8, and 10 band EQ's in SuperFreq
- Oscilloscope, spectrogram, Lissajous meter in Reveal • RTAS, AU, and VST
- Windows XP/Vista and Mac compatible



## BIAS Deck

#BID  
**\$299<sup>00</sup>**

Deck is a professional multi-track recording, editing, processing, and mixing solution for Mac-based digital audio production. Easily spot effects, edit dialogue, and process soundtracks to complex stereo or 5.1 surround mixes. It's a cost-effective editing platform for broadcast, film, and multimedia development of video games, Web podcasts, presentations, and more. Deck's intuitive interface makes taking advantage of the broad range of audio tools fast and easy, all while syncing precisely to a QuickTime or DV clip.

- Ideal for sound design, broadcast and music production
- Record, mix, playback and process up to 64 tracks simultaneously
- SMPTE/EBU timecode-fluent for editing, spotting, and external chase-lock sync
- Built-in DSP effects and 25 free VST audio effect plug-ins
- .OMF, .AIFF, .SDII, .WAV, .SND and QuickTime support



#NAKORE2  
**\$499<sup>00</sup>**

## NATIVE INSTRUMENTS

### Kore 2

Utilizing software and hardware, KORE 2 effectively unites VST and Audio Units' instruments and effects into a single, clearly structured user interface that enables users to find sounds and presets based on their musical attributes, making producing with plug-ins far easier and musical. Its high-resolution hardware controller interacts perfectly with the software, with touch-sensitive, back-lit knobs, bi-directional communication, and a context-specific display.

- Hardware/software system integration of all VST and Audio Units plug-ins
- Ideally suited to be "default" plug-in in sequencer tracks and effect slots
- Graphical control layout corresponds exactly to KORE hardware controller
- Versatile KoreSound format categorizes and manages presets into a single interface
- Bi-directional Audio/Midi interface for live/studio use on USB 2.0 connection

## CELEMONY

### Melodyne Studio 3

Melodyne is a unique application that allows you to edit the pitch, timing, phrasing, and formants of an audio file independently of one another. Manipulating audio in such a detailed fashion has always been difficult but Melodyne provides the service with a stand-alone application or integrated into your production environment via Rewire, VST, RTAS, AU or DirectX support. This is an indispensable tool for creating and editing vocal harmonies or stretching into the experimental for film scoring and remixing.



#CEM3  
**\$569<sup>00</sup>**

- Manipulate audio tracks with MIDI ease
- Outstanding time stretching and pitch shifting
- Copy and paste without "clicks" and "pops"
- Drag and shift interface simplifies conventional editing
- Selectable automatic scale adjustment
- Advanced Audio-to-MIDI function

## ADOBE

### Audition 2.0

Audition is integrated software for audio recording, mixing, editing, and mastering. Its flexibility and control make it an all-in-one tool set for professional audio production for video, radio, and music. Features include unlimited record, mix, and edit tracks in Multitrack View, more than 50 audio effects and DSP tools, a pristine low-latency mixing engine and easy integration with ASIO, VST, DirectX and ReWire support.



#ADA2  
**\$348<sup>95</sup>**

- Comprehensive tool for recording, mixing, arranging, and editing audio
- High-resolution 24- or 32-bit file support for 192kHz HD and DVD quality audio
- Over 5000 32-bit loops included that automatically sync to tempo
- Built-in 5.1 Surround Encoder
- Audio restoration and Mastering capabilities
- PC compatible

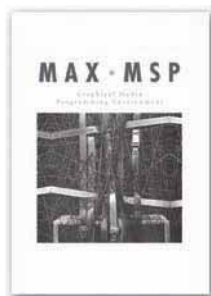

### CYCLING 74

## Max/MSP

#CYSWMMSP  
\$403<sup>95</sup>

MAX/MSP is a graphical software programming environment, in which modular tools and objects are user-connected with virtual "patch cords" to create custom cross-platform music applications for the computer. MAX is the core environment, addressing MIDI, timing objects, control and the user interface. MSP contains over 150 objects pertaining to audio processing, synthesis, and sampling. Combined, MAX/MSP allow the user virtually unlimited creative power.

- Interactive modular program-design software
- Hundreds of modules, objects, and UI tools
- Interactive program editing and de-bugging
- 65 total interactive tutorials
- .AIFF, .WAV, .SDII and .MP3, .MME and Core MIDI support
- Tools for building MIDI synths and samplers
- Hosts VST effects plug-ins and instruments
- File playback includes vari-speed, reverse, and looping

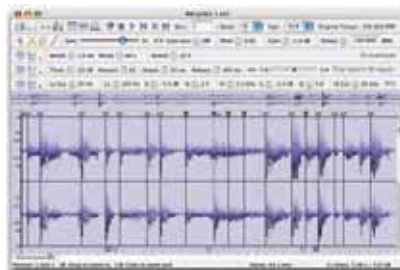

### PROPELLERHEAD

## ReCycle 2.1

#PRRC21  
\$199<sup>00</sup>

ReCycle .21 is a sample-based, cross-platform looping program, one of the first and still the most forward-looking and flexible. This version offers full 24-bit resolution, Mac OSX support, and multiple undo. The program process offers fully-automated sample loop analysis, with tempo change, sound replacement and individual component manipulation, with an intuitive user interface allowing the producer, composer, or musician-programmer greater creativity.

- Supports most hardware samplers with SMIDI protocol
- Loop quantize with swing and groove mapping
- Compression, EQ and Transient Designer sound processors
- Independent loop tempo and pitch change
- Individual sound replacement
- Includes Recycle, Reason Adapted, and Reload
- Loop slices saved as REX2 files for sequencer import
- PC and Mac OSX compliant



### CAKEWALK

## Guitar Tracks Pro 3

#CASWGTP3  
\$99<sup>00</sup>

Guitar Tracks Pro 3 is a Windows-only 32-track software audio recorder with an intuitive portable user interface, designed for guitar-playing musicians and songwriters. The recorder boasts a guitar amp simulator and multi-effects collection, a drum loops library, and a chromatic tuner. The editing and mixing process is highly visual, and finished product may be burned to CD in .WAV or .MP3 file format.

- Up to 24-bit/96kHz resolution
- Up to 32 in/out recording, hardware dependent
- SMPTE/MTC time code generator
- Multiple meter and tempo support
- Audio import and export with high-quality SRC
- Amplitude LE amp simulator, GT:FX multi-effects included
- Automated mix parameters and effects
- Unlimited undo/redo with edit history

### ADOBE

## Soundbooth CS3

#ADSBCS31M  
\$198<sup>95</sup>

Soundbooth CS3 is a stand-alone Windows and Mac-Intel software application for creating and editing audio for film, video, presentation, and Adobe Flash projects. Designed for video or film editors, sound designers, and motion graphics work, the program deploys on-clip controls for intuitive audio clean-up, voice-over enhancement, and effects drop-in. Soundbooth Scores, a collection of easily-customized music themes is included, and additional themes and effects may be downloaded from Soundbooth Resource Central.



- Clip-based cut, copy, and paste
- Time-stretch and pitch-shift
- Intuitive removal of clicks, hum, buzz, hiss
- Spectral Frequency Display waveform analysis
- High-quality audio effects
- Mono or stereo recording with markers
- SRC and bit-depth conversion
- Time-line with frame, minutes and seconds or sample display

### ROXIO

## Toast 8 Titanium

#ROTOAST8  
\$99<sup>95</sup>

Toast 8 Titanium is an ultra-intuitive Mac-based software CD, DVD, and Blu-ray disc-burning utility. The program features single-click CD, movie, and DVD copying, and in this version allows for EyeTV burning and TiVoToGo DVD or iPOD transfers. Toast Titanium 8 also includes DSP functions such as Roxio Jam audio mastering tools, dynamic DJ-type cross-fades, effects processing, normalizing, and track trim.



- File recovery for damaged discs
- Fit-to-DVD compression from 9GB to 5GB
- Blu-ray disc burning up to 50GB file direct from desktop
- Custom DVD menu background creation
- Full-res photo archive discs with slideshows
- Mastering tools and DSP processing
- Comprehensive audio, video, photo and image file support
- Mac OSX 10.4.8 or higher





## STEINBERG Sequel

#STS1  
**\$99<sup>99</sup>**

Sequel is a cross-platform audio software solution for music composition and performance, designed for the novice. This easy-to-use program contains the basic recording, editing, mixing, and performance tools necessary for complete music creation. Sequel is equipped with a large collection of genre-hopping loops, instrument sounds, and drum kits, along with EQ, dynamics and effects processing on each channel.

- Complete music creation package for beginners, hobbyists
- Full multi-track recording, editing, and mixing
- 5000-loop cross-genre library
- 600 instrument, 60 drum kit sounds
- Software tempo sync and key transposition
- Live-performance mode for on-the-fly remixing/arrangement
- Linear or pattern-based recording
- PC or Mac compatibility



## AUDIO EASE BarbaBatch V4

#AUBB  
**\$335<sup>00</sup>**

BarbaBatch V4 is a powerful Mac-based batch-file conversion utility offering vast file format support. The program supports up to 192kHz sampling rates, pro formats such as BWF, Sonic Solutions, 32-bit float files, and Redbook CD image extraction. Low-res audio may be compressed and up-sampled for improved fidelity, automated CD-ripping is supported, and audio-snippet conversion to multiple streaming formats is available.

- Pro conversion utility for audio mastering and music production
- Streaming and low-res file "doctoring" for web delivery
- SRC from 1Hz to 192kHz
- Flexible stereo channel processing
- Normalizing, gating, look-ahead peak limiting
- Region extraction to separate files
- All files with fade-in/fade-out once imported
- Practically universal file format support



## IMAGE-LINE FL Studio

#IMFLSE  
**\$99<sup>00</sup>**

### Fruityloops Edition

FL Studio Fruityloops Edition is a low-cost and surprisingly full-featured software application for music composition and production, offering both Windows and Intel Mac compatibility. The program provides CPU-dependent track count, audio and MIDI recording, a large selection of virtual instruments, multi-effects and flexible editing, mastering, and audio processing tools.

- Up to 64 simultaneous recording tracks
- Time-stretch, pitch-shift, beat-slice, chop, and mangle
- Pattern- and track-based MIDI sequencing
- Step-sequencer, Piano-roll, automation-clip editing
- Universal MIDI hardware controller support
- Virtual synthesizer collection, sampling tools
- Wide range of synthesis techniques supported
- VST, DX plug-in support, large effects collection included

## SONY Vegas Pro 8

#SOVP8  
**\$469<sup>95</sup>**

Vegas Pro 8 is a professional Windows-based non-linear editing solution with complete DVD authoring capabilities. The program also offers a powerful set of audio-for-video production tools, with unlimited track count, 24-bit/192kHz recording resolution, and a host of other features. Sound Forge 8, an advanced and intuitively-presented 2-track audio editor, processing, and mastering program, is included in the package, enabling a completely self-contained workflow.



- Full drag-and-drop functionality
- Mouse or keyboard trim tools, ripple editing modes
- HDV, SDI and XDCAM format support
- Customizable workspace with multi-monitor support
- Punch-in audio recording, 5.1 surround mixing
- Effects automation, time compression/expansion
- Multi-effects library included for expanded sound design
- Full DVD authoring suite with image-correction filters

## MAKE Finale Allegro

#MAMHR05  
**\$164<sup>95</sup>**

Finale Allegro is a fast, powerful cross-platform scoring and notation program for educators, students, composers, and arrangers. The software offers a simple, effective user interface, MIDI score playback, multiple methods of note-entry, and the ability to save the score as a MIDI or .MP3 audio file. Finale Allegro includes the SmartMusic Soundfont collection of instrument sounds as an alternative means of score playback.



- Full-score or part creation and printing
- Multiple note-entry methods include mouse, typing
- MIDI or acoustic instrument performance note-entry
- Auto-spacing of notes, lyrics, slurs and ties
- Simplified editing of all MIDI data
- Human Playback feature "performs" score as intended
- SmartMusic Soundfont instruments
- Band-in-a-Box 2- and 3-part auto-harmonizing



## IZOTOPE RX

#IZRX  
**\$279<sup>00</sup>**

Rx is a cross-platform stand-alone audio restoration tool designed to be used in a wide variety of production and archiving applications. The program features 5 different types of noise removal functions, an advanced spectrogram that visually represents the audio at a very high time and frequency resolution, and a streamlined user interface.

- Hum removal eliminates AC hum and line noise
- Declipper rebuilds clipped, distorted audio from A/D and analog overloads
- Declicker eliminates pops, crackles, clicks, digital impulse noises
- Denoiser removes broadband noise, leaves ambience
- Spectral repair removes intermittent noises and fixes audio gaps, dropouts



## NOTION MUSIC Notion

#NONS  
**\$499<sup>00</sup>**

Notion is a cross-platform music performance and composition program using a score-based environment and a sound library and playback engine featuring the sounds of the London Symphony Orchestra. The program is designed for speedy page layout and note entry, offering a set of intuitive key commands and shortcuts.

- Music performance, scoring and publishing program for Mac and Windows
- Up to 128 instruments per score, Ntempo real-time tempo control
- 1000+ voices of polyphony
- Plays back custom key and time signatures, quarter tones
- Automatic score layout and alignment
- 33 levels of playback dynamics



## NOTION MUSIC Progression

#NOP  
**\$99<sup>00</sup>**

Progression is a cross-platform playback and score-generating program written specifically for the guitar. The program will create lead sheets, backing tracks for practice, and includes a sound library featuring electric and acoustic guitars, drums, electric and acoustic bass, and keyboards. A virtual audio mixer is included in the user interface.

- Guitar playback and notation program with sample library for Mac and Windows
- Tablature and notation entry via mouse, keyboard or MIDI
- Simplified click-and-drag editing with delete and note audition options
- Real-time link between tablature and notation staves
- Tab, notation and alternate tunings for banjo, mandolin, dobro and more
- Built-in guitar and bass amp simulator

## IK MULTIMEDIA ARC

#IKAS  
**\$599<sup>00</sup>**

ARC is a cross-platform software room-correction system for DAW-based studios. It is comprised of both measurement and correction plug-ins, along with an omnidirectional measurement microphone. The key function present in ARC is Audyssey MultiEQ technology, which essentially corrects any sonic aberrations present in an acoustic space and allows for much-improved studio monitoring and critical listening.



- Plug-in room correction system for DAW studio spaces
- Improved clarity, imaging and frequency response of studio monitors
- Audyssey MultiEQ corrects room phase and frequency response
- Measurement wizard facilitates program setup, operation
- Ideal engineering tool for multi-room, multi-location recording projects
- Mac and Windows compatible

## NOTION MUSIC PROTÉGÉ

#NOPZ  
**\$69<sup>95</sup>**

Protégé is a budget-minded music performance and notation program designed for generating smaller lead sheet and ensemble scores. The cross-platform software features an intuitive score-based user interface, and a sound library culled from the London Symphony orchestra sample collection for playback purposes. The program includes an audio mixer, and the ability to save score performances as WAV files for export applications.



- Performance and notation program with built-in sound library
- N-tempo feature for real-time score conducting and tempo control
- Note audition and click-and-drag editing
- Up to 8 instruments in a score
- No external playback hardware necessary
- Global key change and tuning adjustment
- Windows and Mac compatible



## WAVE MACHINE LABS

### Drumagog 4.0 Pro

#DIRTS  
**\$439<sup>95</sup>**

The Drumagog 4.0 Pro is a cross-platform drum-replacement plug-in with full RTAS, VST and Audio Units compatibility. The software is designed to automatically replace selected drum tracks with sounds from a large library of drum and percussion samples. The emphasis here is on speedy, powerful operation accompanied by an intuitive and orderly user interface.

- Drum-replacement software with hundreds of drum samples
- Compatible with most high-end DAW host applications
- Multiple triggering modes with visual triggering
- Dynamic tracking follows original sample dynamics
- Automatic delay compensation function when supported by host
- Windows and Mac OS 9, X compatibility

### Drumagog 4.0 Platinum

#WADGPLAT ..... **\$359.00**



## ALGORITHMIX

### ScratchFree

#ALSFP  
**\$1499<sup>00</sup>**

ScratchFree is a Windows-only DirectX/VST plug-in designed for artifact-free removal of annoying pops, clicks, and crackles from various audio sources with zero degradation of the original signal. The program features a high 80-bit internal calculating resolution, and easily handles old vinyl and tape sources for archiving and restoration purposes. ScratchFree operates in 2 modes, de-clicking and de-crackling, offering a user-friendly interface with minimal controls.

- High-end noise removal software for Windows
- Click removal from old vinyl and shellac records
- Detects and removes switching noise, digital cross-talk and static discharge
- Reduces distortion caused by clipping
- Automatic latency compensation with compatible DAW's



## DIGIDESIGN

### Reel Tape Suite

#DIRTS  
**\$439<sup>95</sup>**

Reel Tape Suite is a cross-platform audio plug-in that essentially models classic tape recorders and tape formulations, designed to add a bit of tape saturation color, along with tape delay and flanging to digitally recorded tracks. The software is a collection of 3 distinct plug-in modes, each with its own set of intuitive real-time controls.

- Plug-in analog tape simulator with saturation, delay and flanging modes
- Reel Tape Saturation models classic multi-tracks and tape formulations
- Reel Tape Delay models electro-mechanical tape delay and echo boxes
- Reel Tape Flanger models old-school tape machine flanging techniques
- Windows XP and Mac OS X compatible

## ALGORITHMIX

### NoiseFree

#ALNFP  
**\$1499<sup>00</sup>**

NoiseFree is a Windows-only DirectX/VST broadband noise reduction plug-in featuring an efficient, minimalist control interface and a proprietary, psycho-acoustically optimized algorithm that reduces artifact build-up and preserves the timbre and ambience of the original signal.



- High-end broadband noise reduction plug-in for Windows
- Suitable for high-res DSD post-production with up to 384kHz sample rates
- Removes background hum, hiss, camera or air conditioning noise
- Removes residual noise from vinyl after de-clicking or de-crackling process
- 5-band Noise Profile EQ for optimized shaping and playback

## DIGIDESIGN

### Smack! LE

#DICLE  
**\$359<sup>95</sup>**

Smack! LE is a cross-platform compressor/limiter plug-in with a charming GUI adorned with fat old-school control knobs and a really large VU meter. The software, which is largely designed for musical applications, features 3 compression modes, some unique compression ratios and induced harmonic distortion. Smack! LE basically models the automatic gain reduction behavior found in classic hardware compressors.



- Compressor/limiter plug-in for Pro Tools LE systems
- Three compression modes include electro-optical limiter emulation
- Broad range of compression ratios up to hard limiting
- Harmonic distortion for analog-like size and warmth
- Side-chain processing and side-chain EQ





## BIAS SoundSoap 2

#BISS2  
**\$99<sup>00</sup>**

SoundSoap 2 is a cross-platform stand-alone or plug-in processor that dramatically reduces tape hiss, buzzing, hum, rumble, and background noise without harming the audio you want to preserve. Ideal for "cleaning" noise-related problems associated with shooting video, building websites, multimedia applications, or making music.

- One-step "Learn Noise" button automatically reduces noise
- Manual controls for more precise fine-tuning
- "Preserve Voice" button helps remove noise outside the range of the human voice
- "Noise Only" mode lets you listen only to the noise being removed
- Stand-alone version works with any QuickTime or Windows Media audio or video file
- Macintosh or Windows single-platform registration



## WAVES Native Power Pack

#WANPP  
**\$375<sup>00</sup>**

Native Power Pack is the indispensable audio plug-in toolkit for Tracking, Mixing and Mastering.

- Q10 Paragraphic EQ – the Worlds most powerful EQ
- C1 Compressor/Gate – Frequency Selective Dynamics processor
- Supertap – 2 Multi tap delays with up to 6 seconds of delay
- L1 Ultramaximizer – Mastering grade look ahead peak limiting
- Trueverb – High-Quality natural sounding Room Emulator
- Desser – Precision High Frequency Dynamics processor
- S1 – Stereo Imager
- Plug-in formats include: VST, MAS, RTAS, AudioSuite, Direct X and Audio Units



## ANTARES Auto-Tune 5

#ANAT5  
**\$319<sup>00</sup>**

Auto-Tune 5 is a real-time audio plug-in capable of correcting pitch imperfections in Vocals and Solo Instruments, while retaining all the expressive nuances of the original performance without Distortion or Artifacts.

- Save valuable studio time fixing minor glitches in an otherwise perfect take
- Can be used to create striking special effects
- Automatic mode – Detects Input pitch and automatically corrects it to match scale pitch
- Graphical mode – For meticulous pitch adjustment
- Plug-in formats supported include: VST, MAS, RTAS and Direct X

## SERATO Pitch 'n Time Pro

#SEPNT  
**\$519<sup>95</sup>**

Pitch 'n Time Pro is a high-quality time-compression/expansion and pitch shifting AudioSuite plug-in for the Pro Tools platform. The intuitive user interface and flexible DSP tools allow users to process single tracks or entire mixes with real-time previewing, graphic, and numeric editing modes, and Varispeed mode for drawing automation curves. Pitch 'n Time offers precision time compression/expansion from a ratio of 1/8 speed to 8x speed (independent of pitch), and pitch shifting of up to 36 semitones (independent of tempo) without the artifacts typically associated with these processes.



- Unique patented time compression/expansion and pitch-shifting algorithm
- Multi channel mode: allows processing of up to 48 tracks
- Time-Morph: allows user to stretch out a single note, or change the timing of a loop
- Time stretch by tempo change, length change, target length, or target BPM
- Perfect Pro Tools integration (AudioSuite only)
- Fully Mac and Windows compatible

**Pitch 'n Time LE #SEPNTLE ..... \$259.95**

## WAVES IR1

#WAIR1CR  
**\$600<sup>00</sup>**

IR1 is an exceptional sounding Convolution Reverb plug-in with an extensive library of Impulse Response Samples (with different miking options) that faithfully recreate the sonic environments of over 60 carefully sampled real acoustic spaces, and 60 classic hardware devices. Version 2 features new tools for capturing custom Impulses Responses from rooms or devices.



- Unparalleled native reverb solution for your audio sequencing software
- Flexible classic controls of key reverb parameters
- A Renaissance-based 4-Band Paragraphic Equalizer
- Special "Low CPU" mode for Less CPU usage
- Library captured using state-of-the art techniques
- Plug-in formats include: VST, MAS, RTAS, AudioSuite, Direct X, and Audio Units
- 96kHz resolution



## WAVES

### Renaissance Maxx Native

#WARXNA  
**\$450<sup>00</sup>**

Renaissance Maxx is an extensive collection of great sounding plug-ins featuring Vintage-Inspired Equalization, Dynamics and Reverb, a powerful Vocal processor, Desser, Renaissance Bass, and the Renaissance Channel. This collection is truly the best-of-both worlds, digital precision with an analog sound.

- New processor – Renaissance Channel combines the best of the Renaissance technologies into one channel strip plug-in
- Intuitive Controls – Minimal effort-Maximum Results
- Cross-platform native support
- Plug-in formats include: VST, MAS, RTAS, Direct X, AudioSuite and Audio Unit



## NATIVE INSTRUMENTS

### Guitar Rig 3

#NAGR3KE  
**\$499<sup>00</sup>**

Guitar Rig 3 is a one-stop virtual Amp and Effects solution with "Rig Control," a fully-assignable hardware Footboard controller. Create any imaginable guitar setup easily with an arsenal of classic and modern guitar amps, cabinets, microphones, and effects models.

- True to the original Amp emulation inspired by Mesa/Boogie, Fender, Vox, and Marshall
- Loop Machine for creating loops on-the-fly
- Modern analog modeling, including "Dynamic Tube Response"
- Flexible Cabinet and Microphone simulation: (15) guitar & (5) Bass Cabinets, (4) rotary speakers, (9) mic w/adjustable positioning
- Foot controller doubles as D.I box
- Works as a "Stand Alone" or VST, RTAS, AudioUnit or Dxi plug-in



## AUDIO EASE

### Speakerphone

#AUSP  
**\$450<sup>00</sup>**

Speakerphone is an exciting new plug-in from Audio Ease dedicated to recreating speakers of all sizes plus their natural environments. This powerful software is more than just a distortion or EQ; it has a fully-blown convolution engine with samples of hundreds of speakers from bullhorns, walkie talkies, cell phones, laptops, ear buds, guitar amps, etc.

- Comprehensive speaker simulator plug-in
- Convolution engine with samples of hundreds of speakers
- Built-in convolution reverb
- Indispensable tool for post production audio
- Add dial tones, operators, crackle and pop from vinyl
- Effects include: distortion, tremolo, delay, a variety of EQ and dynamics
- Mac-OSX RTAS, Audio Unit, VST, MAS, Windows- RTAS, VST

## IZOTOPE

### Ozone 3

#IZO3  
**\$199<sup>00</sup>**

Ozone 3 is an audio plug-in that delivers a complete integrated suite of world-class mastering processors that combine analog modeling with 64-bit digital precision, in a single powerful user interface. This CPU-efficient plug-in supports up to 192kHz sampling rate and includes all of the following processors: Multi-band Dynamics, Paragrophic EQ, Multi-band Harmonic Exciter, Multi-band Stereo Imaging, Mastering Reverb, Loudness Maximizer, and Dither.



- Analog-modeled modes throughout for added warmth
- Real-time analysis tools with FFT-based spectrum display
- MBIT+ dithering for optimized word length reduction
- Comprehensive preset library & extensive mastering and dithering tutorials
- Plug-in formats include: VST, RTAS, Audiosuite, DirectX, and Audio Unit
- Mac and Windows compatible

## IZOTOPE

### Trash

#IZT  
**\$159<sup>00</sup>**

Trash is an all-purpose distortion processor plug-in that uses high fidelity, 64-bit internal processing to selectively add subtle or extreme distortion to your tracks. This extremely flexible multi-band, dual-stage distortion plug-in provides: 48 algorithms, 85 speaker cabinet models, 3 microphone models, 36 sweepable filter types, dynamic and delay processors, and a comprehensive preset library.



- Distortion types include: overdrive, distortion, fuzz, retro, and faulty
- Filter types include: analog, resonant, clean, and saturated
- Multi-band compression and gating
- Delay modeling includes: analog, lo-fi, and tape-style
- Up to 192kHz compatible
- Plug-in formats include: VST, RTAS, Audiosuite, DirectX, and Audio Unit
- Mac and Windows compatible



**IK MULTIMEDIA**  
**Total Studio Bundle** #IKTSB **\$999<sup>00</sup>**

The Total Studio Bundle is a cross-platform desktop music performance and processing software solution. The collection is rich in sample-based 16-part multi-timbral virtual instruments, electric bass and guitar amplifier, cabinet and effects modeling, a dedicated reverb effects group, and a mastering effects complement. The Total Studio Bundle is a comprehensive plug-in solution for virtually all major DAW software.

- SampleTank 2.1 XL with 6.5GB of samples
- Sonic Synth 2 virtual synth with 8GB of samples
- Miroslav Philharmonik orchestral group
- Ampeg SVX Bass amp/FX modeler
- AmpliTube 2 guitar amp/FX modeler
- Classik Studio Reverb suite
- T-Racks mastering suite



**IK MULTIMEDIA**  
**AmpliTube 2** #IKAT2PI **\$319<sup>00</sup>**

AmpliTube 2 is a complete guitar effects and amplifier/speaker modeling application that can be used in stand-alone mode, or as a plug-in within host software. Choose from among 21 stomp effects, 11 rack effects, 14 preamps and EQ's, 7 power amps, 16 cabinets, and 6 modeled microphones. At your disposal are 20,000 combinations of custom sounds, or choose from 400 ready-to-go presets.

- Over 80 name-brand gear emulations of amps and effects
- User-friendly graphic interface
- Run 2 guitar rigs simultaneously
- Includes SpeedTrainer – play along with songs, change tempo - keep pitch
- AU, VST, RTAS
- Mac and Windows compatible (IntelMac and Vista compatible)



**IK-MULTIMEDIA**  
**T-Racks** #IKTRPI **\$319<sup>00</sup>**

T-Racks is a collection of vintage modeled plug-ins that provides all the necessary tools for creating superb, tube-toned masters with astonishing warmth and clarity. Combined with your favorite audio sequencing software, T-Racks's familiar user interface and high-quality presets enhance your final mixes.

- Complete Mastering Suite software plug-in
- 6-band analog-modeled parametric EQ
- Classic Tube modeled stereo compressor/leveler designed for mastering
- Multi-band master stereo limiter
- Musical soft-clipping output stage
- 32-bit floating-point resolution
- Plug-in formats include: HTDM, RTAS, VST, DXi, Audio Unit
- Mac and Windows compatible

**WAVES**  
**APA 32 / APA 44**

#WANSAPA32 **\$600<sup>00</sup>** #WANSAPA44M **\$1350<sup>00</sup>**

The APA 32 and APA 44 are audio processing accelerators that provide external DSP for running multiple Waves plug-ins without taxing the host CPU. These powerful DSP processors connect via a standard Ethernet connection, support multiple users over a standard LAN network, and interface with both native and TDM digital audio workstations.



- The APA 32 is a 1-space rack-mount unit designed for machine rooms
- APA 44 is a half-rack unit with 30% more processing power than the APA 32
- Share power with multiple users over a standard LAN network
- IRL and Q-Clone plug-ins are included free (limited time promotion)
- Available Netshell Plug-ins: IR Convolution Reverb, L3, Lin EQ, Lin MB, C4, Renaissance Reverb, Renaissance Channel, SoundShifter, Morphoder, TransX, and Q-Clone
- Multiple units (up to 8 per host) connect via Ethernet switch

**T.C. ELECTRONIC**  
**PowerCore Platform**

The PowerCore Platform is an extremely powerful hardware/software processing solution that provides massive amounts of DSP processing power to your DAW without taxing your host computer. Comprised of a dedicated hardware processor and plug-ins, this flexible DSP workhorse is available in three different hardware configurations.



- Choose between PCI MkII, Compact or FireWire version
- Significant DSP upgrade to compatible DAW's
- A broad selection of high-quality plug-ins are included
- Open platform with a growing number of 3rd-party plug-ins
- Multiple PCI, Compact or FireWire units can be used in one system
- VST and AudioUnits support • Mac and Windows compatible

**PowerCore PCI MkII** #TCPCPCIMK2..... **\$799.00**  
**PowerCore Compact** #TCPCC..... **\$799.00**  
**PowerCore FireWire** #TCPFW..... **\$1199.00**





## URS Classic Console EQ Bundle Native

#URCCBNAT  
**\$374<sup>99</sup>**

The URS Classic Console EQ Bundle provides high-quality software emulations of two world-famous hardware console EQ's. The URS Series A digitally recreates the sound of API's 550B vintage Four Band Equalizer, and the Series N recreates Neve's 1084 vintage Five Band Equalizer (3 bands plus HP/LP Filters).

- Classic analog console EQ emulation
- URS A Series: 4 bands of EQ with 7 center frequencies each, Low & High bands are Peak/Shelf switchable, low-mid & mid-high are Peaking types
- URS N Series: 5 bands of EQ, Low & High bands are Shelving, mids are Peaking types,  $\pm 12$ dB filter boost/cut, Hi-Q button on the mid band
- Plug-in formats include: RTAS, VST, and Audio Units
- Mac OS 9, OS X, and Windows XP compatible



## WAVES Native Masters

#WAMNB  
**\$675<sup>00</sup>**

Native Masters is the Definitive Suite of plug-ins for Professional Mastering, delivering stunning transparency, control, and sonic excellence with no phase distortion.

- Linear Phase Equalizer – Innovative Phase Linear Filters, preserves original musical balance
- Linear Phase Multiband – Independent Compression, EQ, and Limiting on 5 user-defined frequency ranges with Linear Phase crossovers
- L2 Ultramaximizer – The next step in Peak Limiting and Level Maximization, 48-bit internal processing, High-Quality Re-quantization to 24-, 22-, 20-, 18-, 16-bit and ARC
- Plug-in formats include: VST, MAS, RTAS, AudioSuite, Direct X and Audio Units



## WAVES Native Restoration Bundle

#WARB  
**\$900<sup>00</sup>**

The Native Restoration Bundle is a real-time, cross-platform software suite consisting of four specialized audio plug-ins that set a new standard in software-based noise reduction and restoration. Fast and incredibly easy to use, the Native Restoration Bundle is an indispensable toolkit for post-production and forensic audio applications.

- X-Noise: Intelligent broadband noise reduction
- X-Click: Highly-effective fully automated or manual click removal
- X-Crackle: Crackle and Surface noise reduction for LP restoration
- X-Hum: Specialized ground-loop Hum and Rumble filtering
- Plug-in formats include: RTAS, AudioSuite, VST, MAS, DirectX
- Windows and Macintosh compatible

## FOCUSRITE Liquid Mix

#FOLM  
**\$799<sup>99</sup>**

The Liquid Mix is a unique multi-channel compressor & EQ processor/ dedicated control surface. It uses convolution emulations of classic compressors and EQ's that run as plug-ins on the host DAW. It's capable of powering 32 instances without affecting the host CPU's performance. Compatible with most audio software including Pro Tools, it can greatly empower both the professional and home studio's mixing capabilities.



- Includes 40 classic compressors and 20 EQ's
- Compatible with both Mac and PC
- Low latency firewire connection/VST, AU, and RTAS
- Large LED metering and dedicated plug-in control surface
- Bus-powered through firewire or included power adaptor
- Uses the same dynamic convolution processes as the Liquid Channel

## UNIVERSAL AUDIO UAD-1 Flexi-Pak

#UNUAD1FP  
**\$699<sup>00</sup>**

The UAD-1 Flexi-Pak is a powerful custom-built DSP card that combines high-quality Reverbs, EQ, and Vintage Analog Emulation plug-ins. This cross-platform PCI card provides the 1176SE Limiting Amplifier (a low DSP version of the classic 1176LN) and authentic digital replicas of the Pultec EQP-1A, RealVerb Pro room modeler, CS-1 Channel Strip and Nigel guitar effects processors. Complete integration of DSP hardware and over 20 software plug-ins provides a serious upgrade to any audio workstation. Additional plug-in included as 14 day demos.



- \$500 USD plug-in voucher included for additional UAD plug-ins
- Tested and approved with all major DAW systems
- Zero CPU load supporting up to 192kHz
- Plug-in formats include VST, MAS and Audio Unit

**McDSP**  
**Classic Pack**

#MCBCPN  
**\$749<sup>00</sup>**

The McDSP Classic Pack gives you four very useful plug-ins for fine-tuning your mix within the Pro Tools recording environment. Analog Channel emulates the sounds of



high-end analog tape machines, tape and channel amplifiers. CompressorBank is a high-end compressor plug-in designed to deliver the sounds of vintage and modern compressors, while maintaining complete control of dynamic compression. FilterBank brings you the sounds of vintage and modern equalizers and filters while MC2000 adds complete multi-band compression to your toolbox.

- Written for all Pro Tools platforms
- Library of presets emulating analog systems
- Mono and stereo versions
- Ultra low latency
- Ready to plug and play right out of the box



**ANTARES**  
**AVOX**

#ANAVB  
**\$499<sup>00</sup>**

The AVOX vocal toolkit is a bundle of five state-of-the-art vocal processing modules that give you all the tools you need to create stunning vocal tracks in any musical style as well as design unique vocal effects for audio post-production applications. These powerful plug-ins use unique vocal modeling, and sophisticated processing algorithms to precisely shape and fine tune vocal performances.

- Throat – Physical Modeling Vocal Designer
- Duo – Vocal Modeling Auto-Doubler
- Choir – Vocal Multiplier
- Punch – Vocal Impact Enhancer
- Sybil – Variable Frequency De-Esser
- Includes iLok USB smart key
- Plug-in formats include: VST, RTAS, and Audio Units
- Mac OS X and Windows XP compatible



**ANTARES**  
**Harmony Engine**

#ANHE  
**\$299<sup>00</sup>**

Harmony Engine is a real-time, cross-platform plug-in that generates vocal harmony arrangements up to 4 parts in density with formant-corrected, independent voice characters, vibrato and panning settings. The software supplies several harmony-generating modes, humanizing features, and a real-time preset grouping system for harmonies and vocal types.

- Software vocal harmony generator with up to 4-part functionality
- Throat Modeling processes harmonies through physical models of vocal tract
- Multiple harmony control modes include automatic and individual note control
- Spread and Register control modes to set pitch range and harmony styles
- Voice Parameter Preset function to create and recall up to 6 unique vocal ensembles
- Windows XP and Mac OS X compatible

**SOLID STATE LOGIC**  
**Duende**

#SODUENDE  
**\$1565<sup>00</sup>**



The Duende is a professional Firewire DSP dynamics effects processor that uses SSL-designed plug-in software based on that company's renowned mixing consoles. The unit provides powerful EQ and Dynamics processing for cross-platform native systems, or integrates nicely with other dedicated DSP environments. The Duende serves up to 32 channels of processing, and supports multiple sample rates and RTAS, VST and Audio Units file formats.

- Rackmount Firewire DSP processor with 40-bit FPU
- SSL-developed plug-in design based on C-200 digital console
- Powerful 4-band parametric EQ's based on G- and E-series analog consoles
- Dynamics section with variable parameter control
- Completely variable Expander/Gate
- Compressor/Limiter with Peak or RMS detection
- Intense LPF and HPF filtering with pre- or post-EQ, sidechain placement
- Bus compressor based on legendary SSL 4000 G-series console

**Mini Duende** #SODM..... **\$795.00**

**WAVES**  
**GTR3**

#WAGTRSONA  
**\$285<sup>00</sup>**

The Waves GTR3 System is an integrated hardware/software amp modeling solution for Mac and PC. It is comprised of the hardware Guitar Interface (made in collaboration with Paul Reed Smith Guitars), and Waves Amp & Waves Stomp software plug-ins. It was designed to provide recording professionals with a level of sound quality and performance previously unattainable in software.



- Unequaled realism in tone of clean, overdriven, and saturated amp sounds
- PRS guitar interface: 1/4" input, XLR (switchable mic/line) & 1/4" outputs
- Input gain control and ground lift switch
- (7) amp models & (23) classic and original effects
- Intuitive virtual pedal board with extensive MIDI control
- Plug-In formats include: RTAS, Audio Suite, VST and Audio Units
- Mac OS X and Windows 2000/XP



#WAL3NA  
**\$450<sup>00</sup>**

## WAVES

### L3 Maximizer Native

The L3 Maximizer Native is a ground-breaking, cross-platform mastering tool for Native DAW users. Presented as a pair of multi-band peak limiters called the Multimaximizer and more minimalist Ultramaximizer respectively, both employ Waves' proprietary PLMixer engine, and offer a combination of transparent phase correction, minimized intermodulation, and, yes, maximized, distortion-free loudness. If you're looking for a clearer, louder mix with some tone to it, look no further than this program.

- Multi-band mastering peak limiter plug-in package for Native DAW users
- Linear phase crossover with user-selectable crossover points
- Single master threshold control
- 12dB boost/cut for each band
- Separate dithering and noise-shaping section
- Transparent sound and operation



## IK-MULTIMEDIA Ampeg SVX

#IKASVXPI  
**\$319<sup>00</sup>**

Ampeg SVX is a high-end virtual bass amplifier plug-in with "component by component" models of Ampeg's most sought-after bass amps. Designed in cooperation with Ampeg, this all-in-one recording solution for bass features: mix-and-match amps and cabinets, six fully configurable stompbox effects, and a high-precision tuner.

- Legendary Ampeg bass tones, now available in plug-in format
- 4-signature Ampeg bass amp models: SVT Classic, SVT 5 PRO, BA500, and the BR15R
- 5-signature Ampeg cabinet models: 1x15", 2x10", 2x12", 4x10", 8x10"
- 10 analog-modeled effects on 6 slots with flexible routing
- Plug-in formats include: RTAS, HTDM, VST, DX and AudioUnits
- Macintosh and Windows compatible

## McDSP Emerald Pack

#MCBEPN  
**\$1299<sup>00</sup>**

The Emerald Pack is a collection of world-renowned emulations of vintage equalizers, compressors, tape machines, and channel amplifiers, combined with custom console modeling, and the latest technology in convolution reverb and mastering limiters. This package also includes Synthesizer One, which combines wavetable and analog oscillators, a completely modular design and flexible filtering. Waveforms may also be drawn, generated from a suite of tools, or imported from an audio track within this unique synth.

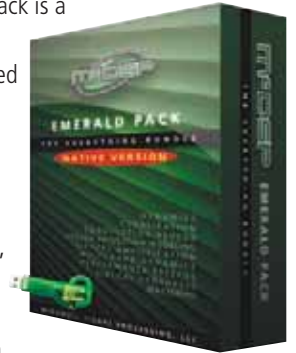

- Deluxe plug-in package written for all Pro Tools platforms
- Revolver high-powered convolution reverb
- Chrome Tone guitar amp modeling and effects
- Pre-programmed green iLok included
- Contains printed manual

## AUDIO EASE Altiverb 6

#AUAV  
**\$520<sup>00</sup>**

Altiverb 6 is a convolution reverb plug-in for Mac OS X and Windows XP that uses top quality samples of real spaces to create reverb, ranging from Sydney Opera House to the cabin of a fire truck. It offers an extensive set of parameters, supports all professional plug-in formats, offers parameter automation and surround capability. Every few weeks there are free new spaces available for download on the Audio Ease site, giving you a tremendous selection of reverb types to choose from.



- Powerful multi-output convolution reverb
- Large library of sampled spaces available
- Informative visual layouts and descriptions for sampled venues
- "Waterfall" display shows reverb frequency content over time
- Low, Mid, and High frequency-damping controls

## WAVES Vocal Bundle Native

#WAVNB  
**\$750<sup>00</sup>**

Vocal Bundle is a comprehensive vocal toolkit made up of three classic Waves plug-ins and two brand-new processors. It includes: Tune (high-quality pitch correction and melody transformation), DeBreath (removes breath sounds on vocal tracks), Renaissance Channel (virtual channel strip), Renaissance DeEsser (sibilance attenuator) and Double (double track emulator).



- (5) powerful Vocal plug-ins
- Formant-corrected pitch processing
- Automatically reduces or removes breath sounds on vocal tracks
- Renaissance Channel: vintage-modeled EQ, compression, gating and limiting
- Plug-in formats include: MAS, VST, RTAS, Audio Units and AudioSuite
- Mac OS X and Windows XP compatible





## IZOTOPE Spectron

#IZS  
**\$99<sup>00</sup>**

Isotope is a 64-bit Spectral Domain Effects Processing plug-in that allows users to split audio into thousands of frequency bands, apply effects independently to each band, and then resynthesize the audio to create entirely new sounds. This incredible sound-shaping tool provides limitless possibilities for exciting new sounds in an elegant, easy-to-navigate user interface.

- 64-bit internal processing
- Up to 192kHz sampling rate
- Morphing for vocoder-style effects
- Delay with independent feedback control
- 4-stage chorus/flanger effects
- Fully-automatable, triggered filters, and frequency-selective panning
- Comprehensive preset library
- Plug-in formats include: VST, RTAS, HTDM, Audio Units and DirectX
- Mac OS X and Windows 98SE, ME, 2000 and XP compatible



## TASCAM GigaPulse VST

#TAGIGAPVST  
**\$249<sup>00</sup>**

The GigaPulse VST is an affordable convolution reverb plug-in for Windows that can emulate any room, acoustic space, vintage EQ, or microphone setup with precise control over critical parameters. Unique features like mic modeling, selectable room position, and tail extension make the flexible GigaPulse VST a great choice for top-quality room emulation.

- Acoustic space modeling via exclusive convolving algorithms
- Microphone modeling can be applied to the environment or used alone
- Tail Control reduces computer processing load to free up your CPU for more instances
- 2D mic/source placement – move your source to up to 18 locations in a room
- Move the mic using the Perspective slider
- Create new impulses from your own recordings
- VST Plug-in format for Windows XP

## McDSP Project Studio

#MCBPSLE  
**\$449<sup>00</sup>**

Project Studio is the most comprehensive LE plug-in bundle ever, featuring award-winning equalizers, filters, and compressors, plus a sound synthesizer, guitar-amp



modeler, convolution reverb, mastering limiter, and analog tape machine simulator. This set is the perfect addition to any Pro Tools LE or M-Powered system and gives you the tools to truly begin sonically sculpting your work. Whether you track a full band, record your own songs, edit audio for video, or produce voice-overs, you will be able to put the finishing touches on your project.

- Available for Pro Tools LE and M-Powered
- Vintage tape and analog circuit emulation
- Revolver LE provides rich acoustic spaces
- Includes pre-programmed iLok
- Printed Quick Reference Guides

## CYCLING 74 Pluggo

#CYSWP  
**\$162<sup>50</sup>**

There has never been anything close to the selection of plug-ins assembled in Pluggo. With its range of sound design possibilities, it is a real-time interactive audio processing, modulation, and synthesis environment that works right inside your favorite audio application. The wide range of effects categories includes delays, filters, pitch effects, distortion, granulation, spectral effects, modulators, multi-channel effects, synthesizers, audio routing, reverb and dynamics, and visual display. This package delivers lots of interesting plug-ins for a modest price.



- More than 100 audio plug-ins
- MIDI support and host synchronization
- Modulators alter other plug-ins for unique results
- Up to 8 channels of audio patchable between plug-ins
- Both Windows and Mac compatible

## DIGIDESIGN TL SPACE NATIVE EDITION

#DITLSN  
**\$495<sup>00</sup>**

The TL Space Native Edition is a cool RTAS and Audio Suite convolution reverb plug-in designed for use with Pro Tools LE systems. Appropriate for music recording and post-production requirements, the software combines rich samples of actual acoustic spaces with sophisticated DSP algorithms for highly realistic programming and sound design in an intuitive operating environment.



- Powerful reverb engine with mono and stereo formats
- Realistic spatial renderings combine sampled spaces and DSP
- Large preset library with dedicated browser
- Mac OSX and Windows XP compatible

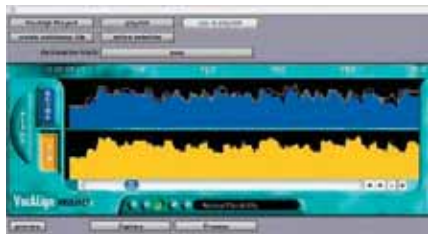

## SYNCRARTS

### VocAlign Project

#DISAVPQ  
\$295<sup>00</sup>

VocAlign Project is an Audio Suite plug-in designed for time-aligning vocals, dialog, or instruments in Pro Tools. It reduces the need to re-record performers and drastically reduces editing time. User interface allows adjustment of selected audio regions for processing, and the scrolling, scalable display allows visual confirmation of sync.

- Audio Suite plug-in for Pro Tools
- Automatically aligns two audio signals
- ADR-lip-sync replacement dialog instantly
- Music – Tighten up backing vocals, lead vocals, or instrumental performances
- Works with 16-bit and 24-bit audio
- Maximum Sample Rate: 192 kHz
- The aligned audio can be auditioned within VocAlign Project
- Sophisticated pattern matching
- User-adjustable processing presets
- Windows and Mac



## WAVES

### Tune

#WATNE  
\$450<sup>00</sup>

Tune is a plug-in that runs via ReWire and allows complete control over the pitch, vibrato, and melody of a prerecorded vocal track. You can use it right away with its default automatic correction mode, or fine tune its operation with a host of parameters and controls. Whether you're changing a singer's note, adding or smoothing out vibrato, Tune will work transparently and naturally.

- 24bit 96kHz
- RTAS, Audio Suite, VST, and AU
- Easily sync MIDI notes to match instrumentation with vocal melody
- Piano roll, pitch editor, waveform view
- ReWire support allows normal playback function, looping, and scrolling
- Mac and Windows compatible



## IK-MULTIMEDIA

### CSR-1: Classik Studio Reverb

#IKCSR  
\$319<sup>00</sup>

The CSR-1: Classik Studio Reverb is a suite of four reverb plug-ins modeled after classic high end studio reverb hardware masterpieces. This high quality, musical reverb processor includes four different reverb algorithms: Classik Hall/Room, Classik Ambience, Classik Plate, and Classik Inverse, and in advanced mode users have full access to more than 50 reverb parameters.

- State-of-the-art DSP-based reverb algorithms
- Highly customizable Modulation Matrix
- Smooth parameters morphing capabilities
- Adjustable input and output reverb width
- (2) internal LFO's and (2) internal Envelope generators
- High-quality reverb filtering
- Full automation
- Plug-in formats include: VST, RTAS, Audio Units and DirectX
- Mac OS X and Windows XP compatible

## McDSP

### Revolver

#MCP1RN  
\$449<sup>00</sup>

Revolver is a high-powered convolution reverb that operates like no other, providing total impulse response control, dedicated and routable EQ, two sync-able delay lines, a reverb decay crossover network, and specialized stereo imaging for unprecedented flexibility.

Additional acoustic spaces and outboard gear can be modeled in just a few minutes with the Revolver impulse response tools and images of the included impulse sources are available. All parameter adjustments are heard immediately without muting the outputs during any control updates so there is no need to wait while the reverb is re-rendered.

- Huge library of rare vintage reverbs and acoustic spaces
- Total impulse response manipulation
- Three-band routable EQ
- Tools for creating custom impulse responses
- Mono and stereo versions



## WAVES

### Q-Clone

#WAQCNTDM  
\$750<sup>00</sup>

The Q-Clone is a revolutionary new plug-in that utilizes unique (patent-pending) technology to capture and hold the sound of outboard hardware EQ's. The Q-Clone package consists of two components: Q-Capture (that sends its special capturing signal to your hardware EQ), and Q-Clone (that allows you to save and recall the sound of your outboard EQ inside your DAW session).

Q-Capture constantly samples the hardware unit's sound, tracking every adjustment you make in real time.

- Duplicate the sound of your hardware EQ on multiple tracks simultaneously
- Calibration feature lets you tune Q-Capture precisely to your unit's headroom and dB range
- Q-Clone shows you the EQ curve your hardware unit is creating
- Plug-in formats include: RTAS, Audio Suite, VST, DirectX, MAS, and Audio Unit
- Mac and Windows compatible

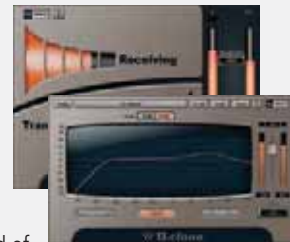



## WAVES SSL 4000

#WASSLNB  
**\$750<sup>00</sup>**

The SSL 4000 Collection is an ambitious set of dynamics and EQ plug-ins for native Mac OSX or Windows XP applications. Developed under license from SSL, and emulating the sonic character and power of the now-classic SSL 4000 series of mixing consoles, the 3 plug-ins are uncanny renditions capable of the same extreme compression and EQ definition that made the real thing such a success with engineers and producers.

- 3 plug-ins based on SSL 4000 series
- SSL G-Master Buss Compressor
- SSL G-Equalizer 4-band parametric
- Broad G-Equalizer Q range for extreme EQ
- SSL E-Channel strip-based original all-discrete design
- Black Knob equalizer for enhanced cut and boost
- Split feature places HPF and LPF before dynamics or in dynamics sidechain

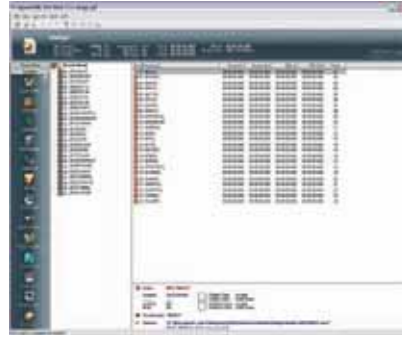

## SOLID STATE LOGIC Pro-Convert

#SOPCS  
**\$699<sup>00</sup>**

Pro-Convert is an audio project translator and file conversion program for Windows. It is designed to allow seamless project movement between Digital Audio Workstations from different manufacturers and supports over 40 applications. Pro Convert allows musicians, composers and producers to work in their DAW of choice and easily export or import their music to and from other audio programs for tracking, mixing or mastering purposes.

- Audio project translator and batch file conversion program
- Compatible with over 40 applications
- Frame-accurate offset, volume, fade and pan automation curve conversion
- Track markers and PQ data
- Multi-project conversion
- Windows XP/Vista compatible



## DIGIDESIGN Maxim

#DIM  
**\$389<sup>95</sup>**

Maxim is a peak limiter plug-in with a natural sound and an elegant interface, designed for use with Pro Tools HD or LE systems running under Mac OSX or Windows XP. The program uses a transparent, intelligent "look-ahead" process, anticipating peaks and reducing levels without coloring the track or mix sound quality and character.

- Peak limiter with proprietary "level-maximizing"
- Optimizes overall audio input level, preserves track "integrity"
- Combines peak limiting and normalizing functionality
- Fully-automated plug-in parameters
- Built-in 16-, 18- or 20-bit dithering
- Suitable for use on master mixes or individual tracks
- TDM, RTAS and Audiosuite file formats

## DIGIDESIGN DINR LE

#DIDINRLE  
**\$398<sup>95</sup>**

DINR LE is a sensible, intuitive noise-reduction program, compatible with AVID and Pro Tools LE and TDM systems as an AudioSuite plug-in. The software removes anything from tape hiss to amplifier noise, serving both archiving and music production applications. An overlooked feature of DINR is its sound-design capabilities; used "incorrectly" the program is capable of some of the most bizarre ring-modulation, EQ, and filtering effects we've ever heard.



- Intelligent broad-band noise-reduction program
- Artifact-free noise removal in entirely digital domain
- Unique Audition Noise function
- Post-processing Artifact Removal function
- AudioSuite-only plug-in for AVD and Pro Tools systems
- Compatible with Mac and Windows XP Native applications

## DIGIDESIGN Music Production Toolkit

#DIMPTK  
**\$495<sup>00</sup>**

The Music Production Toolkit is an enhanced set of upgrade features and plug-ins for existing Pro Tools LE and M-Powered native systems. Featuring an increased track count of up to 48 mono or stereo tracks with 24-bit/96kHz resolution, the package also includes the high-quality Pro Tools MP3 option and multi-track Beat Detective rhythm correction.



- Enhanced music tools and plug-ins for Pro Tools LE systems
- Digidesign Hybrid virtual synthesizer
- TL Space Native Edition convolution reverb
- SoundReplacer drum sound replacement function
- DINR LE noise-reduction plug-in
- Smack! LE compressor
- Mac OSX and Windows XP compatible





**SRS**  
**Circle Surround VST Pro**

Circle Surround VST Pro is a multi-channel surround encoder/decoder plug-in designed for use with Steinberg's Nuendo and Cubase DAW's. The software allows the engineer delivery of up to 6.1 surround sound through standard stereo transmission or storage media. The program is compatible with AC-3, .MP3, and most other compression codecs, while providing comprehensive output level panning and decode option control.

#SRCSVST  
**\$169<sup>95</sup>**

- Multi-channel encoding up to 7-channel input
- Selectable 44.1, 48 and 96kHz sample rates
- Full-band LS/CS/RS playback
- Accepts stems in up to 6.1 surround formats
- Multi-channel decoding up to 2-channel input, 7-channel output
- Decode modes for Circle Surround, LCRS, stereo and mono
- Dialog Clarity enhancer processing
- True Bass LF extension



**CHANDLER**  
**EMI TG12413**

#CHEMITG  
**\$279<sup>95</sup>**

The EMI TG 12413 is an RTAS plug-in emulation of a classic hardware limiter built into the TG consoles in use at the legendary Abbey Road recording studios in the late 1960's-70's. The program features two versions of the limiter, a 1969 version with the original HOLD input knob, and a 2005 version with the HOLD modified to INPUT gain and providing a 10dB signal boost.

- Software recreation of classic limiter for Pro Tools LE systems
- Adds punch, consistent presence to vocal or bass tracks in a mix
- Hardware original used on many famous recordings
- 2 versions included with differing input gain
- Mac OSX and Windows XP compatible



**BIAS**  
**SoundSoap Pro**

#BISSP  
**\$499<sup>00</sup>**

SoundSoap Pro is a complete cross-platform audio noise-reduction and restoration plug-in, featuring the Broadband, Click and Crackle, and Hum and Rumble restoration tools, along with a user-invoked Noise Gate function. The program is great for tape and vinyl archiving, or for cleaning up problematic tracks on a multi-track digital recording.

- Professional-level audio noise-reduction and restoration plug-in
- Intuitive operation for tape or vinyl archiving, multi-track cleanup
- Broadband mode removes hiss, lighting noise and more
- Click and Crackle ideal for vinyl pops, clicks, transient noise peaks
- Hum and Rumble removes RF and EMI buzz, LF rumble
- Noise Gate for absolute silence between program material
- Spectrogram for real-time visual monitoring of spectral noise
- VST, RTAS, DirectX and Audio Units file formats

**WAVES**  
**Native Plug-In Bundles**

Wave's professional plug-in bundles are an ideal solution for Tracking, Mixing, Mastering, Post Production, Broadcast Production, and Sound Design. Available in a variety of configurations, these bundles support over 20 different audio editing environments on both the Windows and Mac OS X platforms. Waves Native Plug-In Bundles support the following file formats: VST, RTAS, Audio Units, Direct X, and AudioSuite.

**Gold Bundle includes:**

C4 Multiband Parametric Processor, Renaissance Reverberator, Renaissance Compressor, Renaissance Equalizer, L1 Ultramaximizer, MaxxBass, Q10 Paraphraphic, S1 Stereo Imager, C1 Parametric Comander, Enigma, Supertap, MondoMod, Doppler, UltraPitch, MetaFlanger, TrueVerb, DeEsser, AudioTrack, PAZ Analyzer

#WAGNB  
**\$975<sup>00</sup>**



**Platinum Bundle includes:**

All of the plug-ins in the Gold Bundle plus- L2 Ultramaximizer, L3 Ultramaximizer, UltraPitch, Linear Phase Equalizer, Linear Phase Multiband, Renaissance Axx, Renaissance Bass, Renaissance Channel, Renaissance DeEsser, Renaissance Vox, C4, IR-L, Waves Tune LT

#WAPNB  
**\$1575<sup>00</sup>**



**Diamond Bundle includes:**

All of the plug-ins in the Platinum Bundle plus- L3 Multi-maximizer, X-Noise, X-Click, X-Crackle, X-Hum, SoundShifter, TransX, Morphoder, Q-Clone, L3-LL Multimaximizer, L3-LL Ultramaximizer

#WADNB  
**\$2850<sup>00</sup>**



**Mercury Bundle includes:**

All of the plug-ins in Diamond Bundle plus- V-Series, MaxxVolume, L-Series, GTR, Z-Noise, Vocal Bundle, IR1 & IR360 Convolution Reverbs, 360° Surround Tools

#WAMBN  
**\$5625<sup>00</sup>**





## NATIVE INSTRUMENTS

### Battery 3

#NAB3  
**\$199<sup>00</sup>**

Battery 3 is a precision Drum Sampler plug-in that features a powerful new sampling engine as well as enhanced sound shaping and modulation capabilities with sophisticated sample control. The intuitive "Cell Matrix" interface is fast and easy to use by simply loading your sounds into the sample cells, creating a whole new drum kit in a matter of seconds.

- Includes a 12 Gigabyte sample library
- 128 sample layers per cell
- Improved file management with a drum kit selection dialogue box
- Improved voice group and choke group management
- Every cell has a comprehensive set of sound-shaping tools
- Supports (8) stereo and (16) mono outputs
- Compatible with a wide range of sample formats
- Mac and Windows compatible

**Battery 3 Plug-in updater** also available for owners of previous version #NAB3U.. **\$99.00**



## SPECTRASONICS

### Trilogy

#### Total Bass Module

#SPTRIMPA  
**\$299<sup>00</sup>**

Integrating a powerful user interface and huge 3GB library of sounds, Trilogy provides a remarkable all-in-one sampled bass solution for a wide variety of musical styles. Trilogy's core library includes multisampled acoustic bass, electric bass, and synth bass instruments, and its powerful user interface allows users to create unique custom patches.

- Massive 3 Gigabyte core library
- Hundreds of new Electric, Acoustic, and Synth Basses, each with dual layers
- Mix and Match layers for thousands of dynamic combinations
- Highly-detailed, multi-velocity multisample articulations for ultimate expression
- Finger noise layer for ultimate realism
- Powered by custom 32-bit UVI engine
- Easy to use built-in patch management system
- Three envelopes per layer for Pitch, Filter and Amplitude
- Cross platform compatibility: RTAS, MAS, VST, Audio Unit



## MOTU

### MX4

#MAMX4  
**\$279<sup>00</sup>**

MX4 features a unique, Hybrid Synthesis engine that combines several types of synthesis into one virtual instrument Plug-In. Open Modulation Architecture and "Variable Filter Topology" give the user Infinite creative possibilities.

- Multi-architecture Synthesis Engine including – Wavetable, FM (Frequency Modulation), AM (Amplitude Modulation), and Analog Emulation
- Pristine 32-bit sound quality
- Built-in chorus and delay effects
- Supports all standard sampling rates up to 192kHz
- Plug-In formats supported include: MAS, RTAS, and Audio Unit
- Unlimited Voices, Polyphony, and Instantiations (as many as Host CPU allows)
- Mac OS X compatible

## NATIVE INSTRUMENTS

### Absynth 4

#NAA4  
**\$199<sup>00</sup>**

With its unique interface and sonic flavor, Absynth 4 is a powerful virtual instrument that combines sampling and synthesis to create an extremely diverse spectrum of amazing sounds. The creative musical and sound design possibilities offered by its semi-modular architecture and innovative features stretch well beyond the boundaries of existing synthesizers.



- Includes over 1200 Presets
- Generate constantly-moving and morphing textures with the flexible 68-breakpoint envelopes
- Live stereo input allows Absynth to be used as a sophisticated effects processor
- Fully surround enabled
- Download free banks and presets from dedicated online User library
- Mac and Windows compatible

**Absynth 4 Plug-in updater** also available for owners of previous version #NAA4U..... **\$69.00**

## NATIVE INSTRUMENTS

### Massive

#NAM  
**\$199<sup>00</sup>**

With an array of sounds from snarling basses to shimmering leads and a sizable list of 460 presets, Massive delivers a deluge of synthesis for the studio and the stage. Beginners will appreciate its ease of use, while more experienced users can dig deep within its wave scanning oscillators for analog and digital sounds. A step sequencer is included as well as flexible routing and internal effects.



- 460 presets with an emphasis on sonic intensity and integrity
- 3 parallel oscillator modules/11 filter types
- Mac and Windows compatible, stand-alone and host operation
- AU, VST, DXi, RTAS, ASIO, Core Audio, Core MIDI, DirectSound
- Integrated KoreSound browser



## EAST WEST Symphonic Choirs

#EAEW165  
**\$519<sup>95</sup>**

Symphonic Choirs is a professionally-recorded collection of 5 choirs—Boys, Alto (female), Soprano (female), Basses (male), Tenors (male) and Solo Singers. Three simultaneous stereo mic setups are used to record the chromatically-sampled, multi-dynamic vocals, allowing any combination of mics to control the overall tone and ambience. An advanced Wordbuilder utility enables users to type in words for the choirs to sing, while the included Native Instruments KOMPACT sampler provides complete performance control.

- 5 choirs recorded in full 24-bit with 256 voices of polyphony
- Close, Stage, and Hall stereo mic setups blend seamlessly
- Singers recorded in position with non-vibrato, light vibrato, and heavy vibrato
- Special version KOMPACT sampler provides extensive sound shaping
- Assignable Direct-from-Disk playback handles larger samples
- Mac and PC compatible



## MOTU Symphonic Instrument

#MASI  
**\$279<sup>00</sup>**

Symphonic Instrument is a cross-platform virtual instrument plug-in designed to give users access to a huge 8-Gigabyte library of high-quality orchestral sounds for composing, sequencing, and realistic performances. Driven by a 32-bit UVI engine, Symphonic Instrument provides sixteen-part multitimbral operation, controls to adjust individual instruments, and a built-in convolution reverb with a menu for choosing the desired acoustic space.

- Instrument categories include: strings, brass, woodwinds, orchestral percussion, male and female choirs, pipe organs, period instruments, and pianos (including Steinway D and Yamaha C7 pianos)
- Sounds can be directly loaded into MachFive for more advanced layering and programming.
- Up to sixteen different instruments per instance of the plug-in
- Convolution reverb includes a wide variety of acoustic spaces
- Plug-in formats include: VST, Audio Units, DXi, MAS, and RTAS
- Mac and Windows compatible



## SPECTRASONICS ATMOSPHERE

#SPATMMPA  
**\$369<sup>00</sup>**

### DREAM SYNTH MODULE

With a powerful intuitive interface for creating new textures, the Atmospheres Dream Synth Module is a software synthesizer that integrates a massive 3-Gigabyte library of more than one thousand unique sounds and layer elements. Designed by acclaimed sound designer Eric Persing, Atmosphere can provide a broad scope of sounds suitable for a variety of musical and sound design applications.

- Includes 1000 preset patches
- Dynamic layering of sounds for over 1,000,000 mix combinations
- Multimode resonant filter for each layer, plus master filters
- Matrix-style modulation routing, four LFOs
- Powered by a custom 32-bit UVI engine
- Cross-platform plug-in compatibility: RTAS, MAS, VST, Audio Unit

## M-AUDIO GForce impOSCar

#GFIOSC  
**\$99<sup>00</sup>**

The impOSCar is a virtual synthesizer that is a faithful reproduction of the classic vintage OSCar analog syn-



thesizer. This incredible sounding soft-synth features user programmable waveforms, built-in effects, polyphony, programmability, and a unique, easy-to-use interface for mapping MIDI continuous controllers to its programming controls.

- Extremely authentic analog modeling of classic OSCar synthesizer
- Includes 500+ designer patch library
- Powerful effects section
- Full automation support
- Mac and Windows compatible, stand-alone and host operation
- Plug-in formats include: VST, RTAS, MAS, and Audio Units

## M-AUDIO GForce M-Tron

#GFMT  
**\$99<sup>00</sup>**

The M-Tron is a virtual vintage keyboard that faithfully emulates the classic Mellotron popularized by



artists such as the Beatles, Yes, and the Moody Blues. As one of the first sample-based keyboards, each key on the original instrument moved a tape head onto an eight-second tape loop that played a sound such as a violin. In order to replicate the original instrument's unique characteristics as closely as possible, GForce sampled and coded each individual tape, providing M-Tron with over 1GB of samples of real Mellotron strings, choir, flutes, brass, and more.

- Extremely accurate model of classic Mellotron
- Volume, tone, pitch controls
- Attack and Release envelope
- Full automation support
- Mac and Windows compatible, stand-alone and host operation
- Plug-in formats include: VST, RTAS, MAS, and Audio Units





## SPECTRASONICS Stylus RMX

#SPSTYRMXA  
**\$279<sup>00</sup>**

Loaded with over seven Gigabytes of cutting-edge sample elements and loops, Stylus RMX combines dramatic new control over innovative rhythm production tools and performance into a simple-to-use, expandable, groove-based virtual instrument plug-in for MAC and Windows.

- Over 7 Gigabyte core sample library
- Powerful integrated browser for easy auditioning and organizing of grooves
- 8-part multitimbral with multiple grooves and samples per part
- Innovative Chaos Designer adds musical variations and "improvising" within stereo audio grooves
- Integrated FX rack w/24 professional effects
- Expandable with S.A.G.E Xpanders, Groove Control, REX, and ACID sample libraries
- MIDI Learn for easy hardware control of all MIDI parameters



## SYNTHOGOY Ivory

#SYIVORYMPA  
**\$319<sup>00</sup>**

Ivory is a groundbreaking Grand Piano virtual instrument featuring 40 Gigabytes of stunning, new samples of Steinway D, Bosendorfer 290, and Yamaha C7 grand pianos. This multi-platform plug-in is powered by Synthogy's custom sample and DSP engine which delivers a new level of realism in digital sound creation. Each piano is chromatically sampled with all 88 notes at every dynamic level including the extra 9 notes for the Bosendorfer 290 and release samples at multiple velocities and variations.

- Meticulously sampled virtual grand piano
- Custom 32-bit sample playback and DSP engine
- Real Soft Pedal samples at multiple velocities
- Mac support for RTAS, VST and Audio Units
- PC support for RTAS and VST

**Synthogy Italian Grand Expansion Pack** adds an amazing Italian 10-foot concert grand piano to Ivory #SYILIVITA..... **\$129.95**



## EAST WEST Hardcore Bass XP

#EAEW156  
**\$174<sup>95</sup>**

Hardcore Bass XP is a multi-sample bass library comprised of over 6GB of samples. 5 total basses were used to produce a superior general purpose bass tool as opposed to "genre specific" bass categories. The built-in Native Instruments KOMPACT sampler allows multiple layers of bass to be easily blended and crafted, resulting in tones from aggressive plucks and slides to round, solid tones. Patches are expertly programmed and are available in multiple amp configurations.

- Over 6GB of multi-sampled bass sounds
- Fingered, picked, and a stunning fretless bass included
- All samples recorded through modern and vintage rigs enabling custom mixing
- Well suited for Jazz, Rock, and HipHop
- Native Instrument KOMPACT sampler included with Direct-from-Disk support
- Mac and PC compatible

## M-AUDIO GForce Oddity

#GFO  
**\$99<sup>00</sup>**

The Oddity is a virtual synthesizer that authentically emulates the classic ARP Odyssey



analog synthesizer used by many of the pioneers of electronic music. Oddity has some improved features the original Odyssey designers never even dreamed of, including programmability, preset morphing, host-syncable LFO and automation.

- Extremely realistic analog modeling of classic ARP Odyssey
- Programmable, including 384 presets
- Timed morphing between presets
- Full automation support
- Mac and Windows compatible, stand-alone and host operation
- Plug-in formats include: VST, RTAS, MAS, and Audio Units

## M-AUDIO GForce Minimonsta

#GFM  
**\$149<sup>00</sup>**

The Minimonsta is a virtual synthesizer that expertly emulates the classic Minimoog synthesizer; a landmark instrument known to be one of the biggest, fattest synths ever made.



Enhancements to the original include polyphony, programmability, morphing, additional LFO and ADSR, and delay. All parameters map to standard MIDI controllers, allowing you to easily adjust parameters via hardware controllers or record them into your favorite sequencer.

- Extremely authentic analog modeling of classic Minimoog
- Fully programmable with over 2500 factory presets
- Additional LFO & ADSR for matrix modulation
- Monophonic, polyphonic, legato and unison trigger modes
- Mac and Windows compatible, stand-alone and host operation
- Plug-in formats include: VST, RTAS, MAS, and Audio Units



## NATIVE INSTRUMENTS

### Kontakt 3

#NAK3  
**\$399<sup>00</sup>**

Kontakt 3 is a powerful cross-platform software sampler with unrivaled professional features and compatibility, and includes a comprehensive library of top-quality instruments. Features like "Universal Import" (compatibility with virtually every sample and library format), and a "Script Processor" for programming custom modules, make Kontakt 3 a standout choice for applications ranging from simple music composition to complex sound design projects.

- 32-bit/192kHz audio engine with unlimited voices and 64-fold multitimbrality per instance
- Enhanced loop editor with simplified loop slicing functionality • Global mixer with up to 16-channel surround sound
- RAM-saving "Sample Purge" function
- Over 30 filters and effects including stunningly authentic Impulse Response effects
- Plug-in formats include: VST, RTAS, AudioUnit, DXi
- Mac OS X and Windows XP compatible



## IK MULTIMEDIA

### Sonik Synth 2

#IKSS2  
**\$319<sup>00</sup>**

Sonik Synth 2 is a sixteen-part, multi-timbral, sample-based virtual synth workstation with thirty-two built-in DSP effects and 256 notes of polyphony. More powerful than most hardware workstations, Sonik Synth 2 covers an incredibly wide palette of synth flavors, including: analog, digital, FM, physical modeling, wavetable, granular, additive, resynthesis, and more. The built-in search engine with images of the instruments allows you to easily navigate through over 5000 sounds quickly and efficiently.

- 8GB of samples on two DVD's
- Multiple synth engines including STRETCH and Pitch-shift/Timestretch
- Sound editing with full access to 50 Synth-Sampler engine controls
- Easy to use, full MIDI control
- Plug-in formats include: VST, Audio Units, DXi, and RTAS
- Mac and Windows compatible



## SUBMERSIBLE MUSIC

### DrumCore2

#SUDC2  
**\$199<sup>00</sup>**

Drumcore2 is a cross-platform virtual instrument, composing tool, and drum sample player containing over 8GB of high-quality loops, fills and hits performed by a crack corps of stage and studio professionals. The loops have been recorded at varying tempos 5BPM apart for a more human feel, and the program generously offers MIDI file versions of the loops for triggering other sound libraries or hardware samplers.

- Virtual Instrument and drum sample player for drum track creation
- 8GB library of loops, fills and hits performed by stage and session drummers
- Meticulous studio recordings in top facilities with 24-bit/48kHz resolution
- All loops available in both audio and MIDI file versions • Windows and Mac compatible

## KORG

### Legacy Collection

#### Digital Edition

The Digital Edition of Korg's Legacy Collection includes recreations of the M1 synthesizer from 1988, the WAVESTATION synthesizer from 1990, and a new multi-effect plug-in called the MDE-X. The two classic synths run as stand-alone applications or plug-ins, and have been painstakingly reborn as digital entities with all of the tones and controls that made them classics, with added features for today's DAW.



#KOKLCDE  
**\$149<sup>95</sup>**

- Includes the M1, WAVESTATION, and MDE-X effects plug-in
- VST, AU, and Pro Tool's RTAS compatible • The M1 includes emulations of all 19 of its ROM card sounds • The MDE-X has 128 editable effect programs for sound design, recording, etc. • Mac, MacIntel, and PC compatible

## ARTURIA

### Analog Factory

Analog Factory is a virtual instrument collection of analog synthesizer sounds. The software contains 3500 sounds culled from Arturia's collection of Prophet V, Jupiter-8V, ARP 2600V, Moog ModularV, and many other renderings of classic analog synthesizers, all of which may be edited in an essential, "hands-on", knobs-and-levers environment. Analog Factory is a great value for musicians, producers and sound designers.



#ARAF  
**\$199<sup>95</sup>**

- 3500 classic synthesizer sounds
- Fast intuitive performance-style programming
- Ultra-realistic classic synth recreations
- Stand-alone or plug-in functionality
- Mac OSX and Windows XP compatible





## EAST WEST Quantum Leap Voices of Passion

#EAEW174  
**\$445<sup>50</sup>**

Voices of Passion is a virtual instrument with both plug-in and stand-alone functionality, featuring 5 female vocalists from as many different countries performing a variety of vocal phrases in the manner and emotion peculiar to their native lands. The software contains over 8GB of 24-bit/44.1 samples, and is a must for film, media and gaming composers in need of unusual vocal approaches and atmospherics for their scores.

- Virtual instrument female vocal collection with over 8GB of samples
- Polyphony limited by co-processor only
- 5 female singers from Bulgaria, Syria, India, Wales and the U.S.
- Over 1000 ethnic phrases, Welsh language phrase generator
- Uniquely expressive treatments of vowels, words, phrases, and calls
- Mac OS X and Windows XP compatible
- RTAS, VST and Audio Units plug-in formats



## WAY OUT WARE KikAxxe

#WAKA  
**\$49<sup>00</sup>**

KikAxxe is a virtual RTAS, VST, and Audio Unit instrument plug-in that faithfully emulates the venerable ARP Axxe, a classic analog synthesizer. This software rendition adds two features not found on the original: a dedicated 16-step sequencer and a sample-based "drum machine" replete with five kits and its own step sequencer. The KikAxxe comes with a large preset library, but offers full programmability for the more adventurous.

- Classic synth emulation with step sequencer and drum machine
- Analog-style delay/echo effect
- Fully programmable, MIDI mapping to all controls
- Stand-alone or RTAS, VST, Audio Unit plug-in
- Mac and Windows compatible



## M-AUDIO Drum & Bass Rig

#MADBR  
**\$99<sup>00</sup>**

Drum & Bass Rig is a top-quality virtual instrument that incorporates four great sounding modules into one powerful virtual rack. This cross-platform instrument includes: RD-5 Real Drums, EB-6 Electric Bass, LC-7 Loop Creator, and the BL-8 Bassline. Its master MIDI/Mixer section lets you route, split, layer, and mix these four powerful modules in whatever way best suits your performance and recording needs.

- 4 top-quality virtual sound modules
- Stand-alone or plug-in operation
- Module and master effects processors
- Compatible with most popular software
- Plug-in formats include: VST, RTAS, and Audio Unit
- Windows XP and Mac OS X compatible

## CAKEWALK Kinetic 2

#CAK2  
**\$79<sup>00</sup>**

Kinetic 2 is a powerful virtual instrument for Windows that allows users to compose music and create beats with an easy point-and-click interface. It includes 400 instrument patches, featuring genuine Roland sounds (101, 606, 808, 909, more). Kinetic 2's innovative content browser allows quick access to patterns and sounds (by instrument type and music genre).



- Intuitive point-and-click interface
- Hundreds of professionally-recorded music patterns and ACID format loops
- Add Audio loops to the mix for even more rhythmic variety
- Professional studio effects for processing sounds
- Export WAV files of your mix to burn on CD
- Windows 2000 and XP compatible

## EAST WEST Quantum Leap COLOSSUS

#EAEW164  
**\$535<sup>50</sup>**

COLOSSUS is a massive, 32-Gigabyte virtual instrument with a huge 160-instrument sound set including: Drums/Percussion, Guitar Family 60's, Ethnic, Keyboard/Mallet, Orchestra, Piano/E.Piano, Pop Brass, Choir, Vintage Organs, New Age Ensembles, StormDrone, Synth Basses, Synth Leads, and Synth Pads categories. This virtual instrument combines intuitive handling with excellent sound quality, and is powered by the efficient KONTAKT audio engine.



- 256-voice polyphony
- Advanced 32-bit processing
- Direct from Disk playback
- Powerful multi-mode filters, envelopes, and LFO's
- Integrated high-quality reverb, chorus, and delay effects
- Plug-in formats include: VST, RTAS, DXi, and Audio Unit
- Windows and Mac OS X compatible





## M-AUDIO Key Rig

#MAKR  
**\$99<sup>00</sup>**

Key Rig is a versatile virtual instrument that incorporates four great sounding keyboard modules into one powerful virtual rack. This cross-platform instrument includes: SP-1 Stage Piano, MS-2 Polyphonic Synthesizer, MB-3 Electromagnetic Organ, and the GM-4 General MIDI. Its master MIDI/Mixer section lets you route, split, layer, and mix these four powerful modules in whatever way best suits your performance and recording needs.

- Stage piano, poly synth, tone wheel organ, and GM modules
- Stand-alone or plug-in operation
- Variable velocity and controller settings, optimized for M-Audio keyboards
- Dual effects processor for each module
- Plug-in formats include: VST, RTAS, and Audio Unit
- Windows XP and Mac OS X compatible



## NATIVE INSTRUMENTS REAKTOR 5

#NAR5  
**\$399<sup>00</sup>**

REAKTOR 5 is a completely modular real-time sound synthesis, sampling and effects software that is both a collection of hundreds of software instruments, as well as complete studio environment for constructing entirely new and individual instruments. It includes an extensive collection of first-class synthesizers, samplers, drum machines, loop tools, step sequencers, live performance machines, and effects units; ranging from authentic emulations of classic gear to innovative, cutting-edge instruments and sound manipulators.

- Stand-alone or plug-in operation
- Huge collection of unique instruments and sounds
- Pristine, top-quality sound
- REAKTOR Core Technology allowing low level, custom module design
- Plug-in formats include: VST, RTAS, DXi, and Audio Unit
- Windows XP and Mac OS X compatible

**REAKTOR 5 Plug-in updater** also available for owners of previous version #NAR5U. **\$125.00**



## DIGIDESIGN Music Production Toolkit

#DIMPTK  
**\$495<sup>00</sup>**

The Digidesign Music Production Toolkit includes a full range of professional music tools that expand the creative power of your Pro Tools LE or Pro Tools M-Powered system. It includes an impressive collection of plug-ins, a multi-track version of Beat Detective rhythm analysis and correction tool, up to 48 mono or stereo tracks at up to 96 kHz (interface permitting), and the ability to export mixes as MP3 files. The Music Production Toolkit includes a host of powerful plug-ins worth more than \$2,000 that are ideal for creating and producing music.

- Digidesign Hybrid high-definition synthesizer
- TL Space Native Edition convolution reverb
- Smack! LE compressor
- SoundReplacer drum replacement tool
- DINR LE noise reduction plug-in

## EAST WEST Quantum Leap Gypsy

#EAEW172  
**\$355<sup>50</sup>**

Gypsy is a stand-alone or plug-in virtual instrument featuring instruments specifically associated with gypsy culture such as violins, accordions, trombones and Spanish steel-string guitars performed in the authentic gypsy style. The software contains 11GB of high-res 24-bit/44.1 samples representing a viable collection of instruments and styles for use in film and documentary scoring projects.



- Virtual instrument collection of gypsy instruments w/ 11GB of samples
- Instruments include cimbalom, accordion, trombone, gypsy percussion
- Flamenco stylings, dance steps and castanets included
- Mac OS X and Windows XP compatible
- RTAS, VST and Audio Units plug-in formats

## EAST WEST Quantum Leap Ministry of Rock

#EAEW173  
**\$445<sup>50</sup>**

Ministry of Rock is a virtual instrument collection of over 20GB of 24-bit/44.1 samples of drums, electric guitars and electric basses performed in a wide variety of rockin' styles in a variety of acoustic spaces with a variety of amplifiers. Guitars are performed with both clean and distorted tones with both legato and staccato techniques with dual amplifier configurations.



- Virtual instrument with 20GB of rock drums, guitars and basses
- Fender, Gibson, PRS and Ibanez guitars, Marshall, Vox, Bogner and Fender amps
- Fender, Musicman, Spector and Kubiki basses
- Gretsch, Ludwig, Ayotte drum kits
- All instruments listed in single, easily-navigated browser
- Mac OS X and Windows XP compatible
- RTAS, VST and Audio Units plug-in formats



## FIXED NOISE OTTO

#F10  
**\$169<sup>95</sup>**

OTTO is basically a cross-platform virtual instrument library for sound designers and techno or electronica musicians, packed with over 4GB of hits, loops, ambient and spectral instruments, and a custom version of Native Instruments' KONTAKT 2, which itself provides a 600-instrument library. The cross-genre loops and sequences are also found as individual hits, allowing for a creative mix-and-match process not found in other collections.

- Huge 4GB+ collection of loops, sequences and hits
- Perfect for electronica-based composers, sound designers
- Includes 600-instrument KONTAKT 2 library
- Sounds and instruments grouped into categories for quick reference
- Mac and Windows compatible



## EAST WEST StormDrum

#EAEW162  
**\$264<sup>95</sup>**

StormDrum provides over 6GB of loops and multi-samples from 3 world-class percussionists. Thousands of original evolving drum beds, kits, and percussion are available with up to 20-way velocity-switching. Special versions of Native Instruments KOMPACT and INTAKT samplers are built-in, allowing for quick, synchronized loop manipulation, disk streaming, and multitimbral capability. StormDrum delivers big, ethnic-sounding drums with wide dynamic ranges, especially suited for film and multi-media composition.

- 6GB of evolving loops, phrases, and multi-samples
- Unique collection of powerful ethnic drums and instruments
- Styles include: Action Beds, Big Beats, Ethnic Chase, Fastbreaks, Film Tech, and Thunderous
- Synchronize and edit filters, LFO's, pitch, envelopes, effects, and more
- Special Native Instruments KONTAKT and INTAKT samplers included
- Mac and PC compatible



## MOTU Mach Five 2

#MAM52  
**\$459<sup>00</sup>**

MachFive is a powerful cross-platform software sampler created for professional sound design, music production, or broadcast with support for up to 24/192kHz audio. It combines superior sound quality and operation speed with a powerful, flexible synth engine that's compatible with all sample libraries. Samples are handled using an intelligent file management system optimized for browsing and loading libraries quickly.

- Superior sounding cross platform sampler with unlimited polyphony
- Single window allows all editing and performance parameters in one view
- 16-part multitimbral with extensive effects, four effect slots per part
- Drag-and-drop importing of all major sampler formats
- True surround-capable sampler with multi-channel waveform editing
- Fast operation with instant access to all parameters in one window

## ARTURIA Moog Modular V

#ARMMVH  
**\$199<sup>00</sup>**

The Moog Modular is a cross-platform virtual instrument featuring more than 400 unique presets from some of the industry's best sound designers. True Analog Emulation enables an accurate digital reproduction of the Modular's analog circuits, resulting in aliasing-free oscillators, the typical warmth created by the natural instability of the original oscillators and the legendary Moog 24dB low-pass filter. With new ergonomic functionality and audio opportunities, its synthesis possibilities are truly endless.



- Over 400 presets
- Accurate analog circuit reproduction with low CPU cost
- 9 OSC's, 3 filter slots, 2 LFO's, 6 ENV's, VCA's, mixers, triggers, a 3x8 step-sequencer
- Rare sound modules with dedicated presets
- More responsive oscillators, envelopes and filters
- Mac and PC compatible

## ARTURIA minimoog V

#ARMMV  
**\$199<sup>00</sup>**

The minimoog V is a cross-platform virtual instrument capable of accurately emulating the famous musical characteristics of the original minimoog. With over 500 built-in presets, the minimoog V utilizes its sharp filters, aliasing-free oscillators, soft-clipping, and faster envelope and modulation response to be closer than ever to efficiently reproducing the sweet sound of the original. The minimoog V's superior analog emulation and intuitive musicality make it one of the best emulations available today.



- Over 500 presets accurately modeling famous minimoog
- Particularly efficient and simple for leads and bass sounds
- Nearly exact oscillator, envelope and filter response
- Unison mode allows inter-oscillator drifts producing fatter, warmer tones
- True emulation of renowned 24dB Moog 4-stage filter
- Mac and PC compatible



## DIGIDESIGN Velvet

#DIVPI  
**\$249<sup>00</sup>**

Velvet is an RTAS virtual instrument plug-in for Pro Tools systems, featuring uncanny emulations of the Fender Rhodes Suitcase, Mark I and Mark II electric pianos, along with the Wurlitzer A200. Afficionados of the original instruments will marvel at the detail and playability of the 100+ editable presets, which are comprised of high-definition samples and advanced modeling techniques.

- Over 100 classic electric stage piano presets
- Preamp section with tube overdrive, EQ and compression
- Classic tremolo and auto-pan effects
- Vintage Wah-Wah, distortion, Echoplex, and other authentic effects
- Optimized for Pro Tools HD7, LE7 and M-Powered 7 systems
- Mac OSX and Windows XP compatible



## IK MULTIMEDIA Philharmonik Miroslav

#IKMP  
**\$499<sup>00</sup>**

The Philharmonik Miroslav is designed to faithfully reproduce the lush warmth and emotion of orchestral instruments, ensembles, and choirs. It combines over 7GB of the legendary Miroslav Orchestral and Choir sample libraries into a dedicated plug-in instrument specifically tailored for orchestral composition. Recorded in the famous Dvorak Symphony Hall, all instruments have been captured in their proper acoustic orchestral positions, further enhancing their acoustic realism and performance.

- 16-part multitimbral sample-based orchestral workstation
- 7GB of samples comprised of over 1300 orchestral and choir sounds
- 20 Classic DSP effects, 4 insert effects and 4 Master effects with separate sends
- Up to 50 sound-shaping controls per part
- 256 note polyphony
- Mac and PC compatible



## CYCLING 74 Mode

#CYSWMQ  
**\$79<sup>95</sup>**

Mode is a plug-in collection that combines classic synthesis and effects techniques with unique performance control. It features user-friendly arpeggiators, integrated synth effects and simplified control of complex systems, opening creative doors previously seen only in the best hardware devices. Developed by the Creative Synth team, the Mode plug-ins are unlike anything you've heard—deep basses, soaring lead lines and bizarre percussion processed by synchronized effects and even a lopper's paradise of delay lines.

- POLY classic digital/analog synthesis engine
- MONO dual 2-operator FM engine
- BANG percussion module with sample playback, FM, and analog voices
- SPIN time-synchronized effects
- WASH mix of six digital delays with 8X8 patchbays

## ARTURIA CS-80 V

#ARCS80V  
**\$199<sup>00</sup>**

Made famous in past and present films, the CS-80 V utilizes Arturia's outstanding emulation technology to reproduce one of music's "ultimate polyphonic synthesizers." It takes all the great original features and adds innovations such as a modulation matrix, multitimbral mode, an arpeggiator and stereo delay. This inspirational 8-voice synth provides over 400 presets and 64-bit floating point precision with no aliasing below 16kHz.



- 8-voice polyphonic synth with over 400 presets
- Utilizes Arturia's True Analog Emulation technology (TAE)
- Multi-mode allows assigning a different sound to each voice
- Modulation matrix with 12 sources and 38 destinations
- 64-bit floating point with 96kHz sampling rate
- Mac and PC compatible

## ARTURIA ARP2600 V

#ARARP2600  
**\$199<sup>00</sup>**

The ARP2600 V is a virtual instrument with over 400 presets that effectively bring this powerful synthesizer back to life. It provides all the original functions while adding MIDI control, extra polyphony, and the ability to create, save, and recall your own presets. Expanding upon the initial ARP2600 design, innovative features have been added including 4 revolutionary tracking generators, additional effects, and sound design capabilities never before seen.



- Over 400 presets with additional effects and sound innovations
- Up to 32-voice polyphony with Unison possibilities
- Stereo delay and LFO's syncable to host clock
- Exclusive interactive LFO module for creating new real-time modulations
- 96kHz processing with 64-bit floating point capable
- Mac and PC compatible





## DIGIDESIGN Hybrid

#DIHDS  
**\$249<sup>00</sup>**

Developed by the Digidesign Advanced Instrument Research group, Hybrid is a high-definition RTAS software synthesizer for Pro Tools M-Powered and other Pro Tools systems that combines the warmth of classic analog waveforms with digital wavetables. Emulate your favorite classic synth or create something no one has ever heard before. Hybrid comes equipped with 256 preset patches that include a full range of analog and digital sounds, but it is made for tweaking and shaping your own sounds.

- Performance-oriented soft synth
- Tightly integrated with Pro Tools software
- 2 simultaneous parts for creating complex patches
- 3 high-definition oscillators per part
- Step sequencers for arpeggiation and phrase generation



## EAST WEST

### Symphonic Orchestra Gold Bundle

#EAEW160PS  
**\$607<sup>95</sup>**

The Symphonic Orchestra Gold Bundle is a superbly engineered collection of strings, woodwinds, brass, and orchestral percussion recordings. The bundle consists of the original Symphonic Orchestra Gold Edition and the Symphonic Orchestra Gold Pro XP Expansion Set. These high-quality samples are achieved using the best recording gear available, sampling the instruments and sections chromatically.

- Sonically superior orchestral samples
- Expertly recorded reverb release trails
- 35GB of sounds, Reverb, Filter, Delay and Chorus effects processing
- Included Native Instruments KOMPACT sampler
- 32-bit internal sample processing with 256-voice polyphony
- Mac and PC compatible



## NATIVE INSTRUMENTS Komplete 5 Collection

Komplete 5 is an extensive collection of powerful software synthesizers and sound generators encompassing a broad spectrum of classic and futuristic instruments for all styles of music. All of the award-winning instruments countless musicians, producers, and sound designers swear by are now bundled together in one affordable package. The entire collection comes easy to install DVD's and includes a comprehensive 400-page, printed manual.

- Stand-alone or Plug-in versions
- VST, Audio Unit, RTAS, DXi
- Includes four extensive sample libraries
- Windows and Mac OS
- Includes: Absynth4, Reaktor5, Guitar Rig3, Akoustik Piano, Elektrik Piano, B4II, FM8, Pro-53, Kontakt3, Battery 3 and Massive
- Does not include Rig Kontrol hardware for Guitar Rig3 software

## ARTURIA Prophet V

#ARPV  
**\$199<sup>00</sup>**

Utilizing improvements in Arturia's advanced True Analog Emulation technology; the Prophet V virtual instrument is born. There are three user interfaces in the Prophet V: a Prophet 5, a Prophet VS and Hybrid mode. While maintaining every individual nuance of the originals, the Hybrid mode uniquely stacks these two synths on top of each other, combining the warmth of the Prophet 5 with the digital shimmer of the VS.



- Provides Prophet 5, Prophet VS, and Hybrid mode interfaces
- 40 original presets of the Prophet 5 with added mono mode and sustain
- 96 digitally-sampled waveforms of the Prophet VS
- Hybrid mode combines analog subtractive with digital vector synthesis
- Added audio and modulation matrix for both synths
- Mac and PC compatible

## STEINBERG Groove Agent 3

#STGA3  
**\$249<sup>99</sup>**

Groove Agent 3 is the third incarnation of Steinberg's phenomenally successful Groove Agent virtual drummer VST instrument, and is a major step up from previous versions. Groove Agent 3 combines a huge library of drum and percussion sounds with a range of player technologies to give you dynamic, ready-to-go drums, beats, rhythms, and percussion in only a few mouse clicks. It features top-quality drum samples and live recorded drum performances in a massive number of variations covering 123 different styles that automatically sync to your song tempo.



- Add live drum performances to your songs
- Covers almost any style
- Variations with 25 complexity levels per style
- Huge audio library • Import samples and create your own kits



#GFVSM  
**\$129<sup>00</sup>**

## G-FORCE Virtual String Machine

The Virtual String Machine is a set of virtual classic string synthesizers supporting RTAS, VST and Audio Unit plug-in formats. The collection is filled with startling emulations of vintage instruments from ARP, Moog, Crumar, Korg, and many others, and allows the user dual-layering of the program's proprietary Sample Sets and application of all synth parameters for some complex and creative programming.

- Classic string-synth emulation plug-in with 500-plus presets
- Stand-alone or plug-in functionality
- Over 3200 samples from 60 sample sets
- Programmable dual-layering with synth processing and effects
- Mac and Windows compatible



## NATIVE INSTRUMENTS FM8

#NAFM8  
**\$199<sup>00</sup>**

The FM8 virtual instrument plug-in expands upon the famous sound of FM synthesis. Distortion and filter operators, extensive modulation and effects capabilities, an audio input and more are now added to the already powerful FM architecture. Much more than a virtual emulation, the highly expressive FM8 brings 32 different waveforms to the operators, far beyond the stock sine waves. FM8 faithfully reproduces the FM synthesizer with extended sound architecture and expression.

- Virtual FM emulation instrument with 32 waveforms and 512 presets
- Full matrix frequency modulation with 8 operators, no fixed algorithms
- Reads and faithfully reproduces programs of FM classics
- Intuitive graphical editors with flexible envelopes and unlimited stages
- Extended sound processing and effects
- Mac and PC compatible

**FM8 plug-in updater** also available for owners of previous versions #NAFM8U....**\$69.00**



## CAKEWALK Dimension Pro

#CADP  
**\$249<sup>00</sup>**

With its 7GB sound library, Dimension Pro brings over 1500 production-ready presets to your disposal. This advanced sample playback synth is capable of covering every genre of music, from orchestral, ambient and electronica to hip-hop, R&B and pop. Its quick hands-on control of deep editing capabilities including 20 graphical Envelope Generators and 20 tempo-synced LFO's with multiple filters and shapes makes it ideal for sound design in cinema, TV, videos games and commercial sound.

- 7GB sound library of advanced synthesis with waveguide and wavetable oscillators
- Multiple velocity, keyboard switching and crossfading
- Superior sound quality and enhanced acoustic simulation via physical modeling
- Extensive insert and send effects with delays, modulation, EQ's, LFO filters and more
- Full MIDI control matrix
- Mac and PC compatible

## EAST WEST Fab Four

#EAEW170  
**\$355<sup>50</sup>**

Fab Four is a cross-platform RTAS, VST and Audio Units plug-in or stand-alone virtual instrument consisting of guitar, bass, keyboard and drum sounds one might hear on recordings by the Beatles in their heyday. The emphasis here is on authenticity, with the sampling proceedings presided over by the legendary engineer Ken Scott, who was an integral part of the Beatles' recording team. All instrumental and recording equipment is identical to that used in the original recordings.



- Virtual instrument collection inspired by classic Beatles records
- 13GB sample collection
- Authentic period instruments, amplifiers and recording gear used
- Multi-sampled drums matched to styles of particular songs
- Stereo Swap function with stereo and mono playback capabilities
- Mac and PC compatible

## EAST WEST Quantum Leap Pianos

#EAEW171  
**\$445<sup>50</sup>**

Quantum Leap Pianos is a virtual instrument collection of four individually sampled acoustic grand pianos, each meticulously recorded using three microphone positions with multiple velocity recordings per note and dedicated soft, sustain and sostenuto pedal samples. The pianos may be individually loaded. Quantum Leap Pianos is an RTAS, VST and Audio Units plug-in, and functions quite nicely as a stand-alone instrument as well.



- Massive 270GB acoustic grand piano virtual instrument sample
- Bechstein D-280, Steinway D, Yamaha C7 and Bösendorfer 290 instruments
- Pedal resonances for each note recorded at multiple velocities
- Impulse Responses from concert hall included for effects processing
- Mac and PC compatible



## ILIO Tassman

#APAAT5MA  
**\$329<sup>95</sup>**

The Tassman is a modular virtual instrument based on physical modeling technology. Its 50 pre-patched instruments comprise over 1000 presets right out of the box. Classic analog and FM, realistic acoustic instruments including various drums, chromatic percussion, strings, EP's and more are provided with the expression and subtleties not possible with typical sample based solutions. Customizable modules can create synths, effects, envelopes, filters, mixers, I/O, and more. Tassman is a perfect tool for creative, intuitive sound design and performance.

- Physical modeling synth with 50 instruments and over 1000 presets
- Integrated drag and drop browser
- Efficient, up to 192kHz audio engine
- User samples may be imported and used as a tone generator
- All MIDI and audio effects sync to host sequencer
- Mac and PC compatible



## CAKEWALK Z3TA+

#CAZ3TAP  
**\$99<sup>00</sup>**

Z3TA+ (zay'-ta) is a top-of-the line Waveshaping Synthesizer plug-in among the most expressive and inspiring available. It's fully capable of producing authentic vintage sounds or the most modern soundscapes. Features include over 700 professional presets, 32-bit wavetable synthesis, a complete 16 row modulation matrix, a full arpeggiator with over 100 patterns, stunning filters, effects and more.

- Waveshaping Synthesizer plug-in with 64-voice polyphony
- Pristine sound quality with excellent programming flexibility
- 6 OSC's, 60 built-in waveforms and 6 user-loadable waveforms
- Independent Waveshapers for each oscillator with 14 wave transformations
- Extensive effects, EQ, and compression
- VST and DXi compatible



## CAKEWALK Rapture

#CAR  
**\$199<sup>00</sup>**

Rapture is a powerful Wavetable synthesizer with extensive sound-manipulation capabilities. It provides 600 programs and a beautifully-designed interface that's well suited for electronica related music styles. 6 fully-programmable sound-generating Elements feature over 40 Step Generators per patch, allowing users to easily generate rhythmic sequences with multi-mode oscillators, filters and an advanced MIDI modulation matrix.

- Virtual Wavetable synthesizer with 600 creatively-crafted musical programs
- Programs include Basses, Pads, Leads, Arpeggios, Textures, Percussion, and Sequences
- Six-part sound engine with multi-waveform and ring modulation functions
- Mix and modulate all Elements through global FX and dynamic Step Generator
- Graphical step sequencing of pitch, filters and other parameters
- Mac and PC compatible

## NATIVE INSTRUMENTS PRO-53

#NAP53  
**\$199<sup>00</sup>**

The PRO-53 is a virtual instrument designed to authentically reproduce the brilliance, warmth, and beauty of the original Sequential Circuits Prophet-5. Along with 576 built-in programs, 64 programmed by one of the original creators of the unit, the PRO-53 adds unlimited voices, MIDI automation, velocity sensitivity, more effects, filters and more. The PRO-53 can run original Sysex patches but offers more creative tools for live and studio production.



- 576 Classic and modern sounds emulating legendary Prophet-5
- Added invertible filter envelope, audio input, and LFO-envelope retrigger
- Plays original Sysex programs
- Additional effects for chorus, flanging and echo, MIDI-syncable
- Operates both stand-alone or as a plug-in (Mac and PC)

## NATIVE INSTRUMENTS AKOUSTIK PIANO

#NAAP  
**\$199<sup>00</sup>**

AKOUSTIK PIANO combines the expressiveness and graceful playability of three of the world's most reputable pianos, the Steinway D, Bechstein D 280, and the Boesendorfer 290 Imperial—as well as the unique vintage Steingraeber 130 upright—into one virtual instrument. All four pianos are captured in exact detail, their warmth and distinctive characteristics are achieved by combining a specially developed microphone setup with the latest recording technology.



- Four distinctive pianos with the full body and feel of the originals
- Integrated convolution reverb module manipulates space and mic setup
- Ideal for school music labs, stage, and professional production
- Layer Morphing Technology ensures a consistent timbre and seamless velocity
- Highly advanced audio engine with Direct-from-Disk capability
- Mac and PC compatible





## M-AUDIO I Drum

#MAID  
**\$49<sup>00</sup>**

The I Drum adds a fully-programmable drum machine to Mac-only based recording studios. It's easy to use, but loaded with the flexibility and power of a virtual instrument. Create patterns right alongside your current tracks or use any of the hundreds of pre-programmed patterns and rhythms. Many sound-shaping DSP functions are built into the I Drum, including filters, amp envelopes, and bit-reduction, all of which can be utilized while mixing and matching parts and samples.

- Virtual drum machine with hundreds of drum samples, patterns and parts
- Instant gratification with easy drag-and-drop AIFF or WAV files up to 2MB in size
- Up to 99 patterns in a single I Drum file
- Mixer controls for each drum sound
- Designed for Mac OS X platform



## MOTU Ethno Instrument

#MAE  
**\$279<sup>00</sup>**

The Ethno Instrument delivers expressive ethnic instrument sounds combined with authentic world music loops and phrases in one easy-to-use window. From solo instruments to full ensembles, the Ethno Instrument delivers all of the exotic textures you need to take your recordings to the four corners of the globe. It comes with a massive 4GB library of instrument samples from all over the world and adds another 4GB of authentic loops and phrases, instantly tempo-locked to your host software time line.

- Sounds organized by geographic region and category
- Intuitive layout and control access
- Built-in convolution reverb processor
- Disk streaming and multiple outputs
- Plug-in and stand-alone formats



## TOONTRACK EZ Drummer

#TOTT106  
**\$149<sup>00</sup>**

EZ Drummer is a drum sample playback engine and VST or Audio Units plug-in. The software features a huge collection of meticulously recorded drum samples and a user interface designed for simplicity of operation and ease of access. The drag-and-drop method of kit construction and instantaneous sound auditioning process couldn't be simpler.

- Huge, easy-access drum sample plug-in library with 7000 sound files
- 8000 preset drum patterns with auditioning and drag-and-drop functionality
- Humanizer function with drum hit randomizing and non-cycling
- Internal mixer with virtual microphone bleed and level controls
- Stereo and multi-track routing to host software
- Mac and PC compatible

## McDSP Synthesizer One

#MCPIS1  
**\$449<sup>00</sup>**

Synthesizer One for Pro Tools combines wave table and analog oscillators, a completely modular design, flexible filtering, and a dedicated effects section to produce inspiring leads, fat basses, and evolving synthetic textures. Its wavetable editor allows users to create unique waveforms for oscillators and LFO's and may be drawn, generated from a suite of tools, or imported from an audio track. There are also three clock sync-able wavetable LFO's per voice with dedicated multi-mode ASR envelopes.



- Ultra-low latency synthesizer for Pro Tools
- Analog saturation modeling
- Dedicated effects section per preset
- User-definable arpeggiations and sequences
- Mono and stereo version

## VIENNA SYMPHONIC LIBRARY Symphonic Cube

#VICSLVSCA  
**\$4915<sup>00</sup>**

Symphonic Cube is a professional collection of 10 virtual instruments specifically designed to quickly and easily marry raw samples with performance algorithms for stunning authenticity. 550GB of 24-bit samples are provided, including hundreds of inspiring articulations which can now be combined into a single Preset on a single MIDI track. The appropriate articulations and nuances are automatically selected in real time by Vienna's proprietary Performance Detection, making composing more natural, efficient and fun.



- Stunning collection of over 550GB of 24-bit orchestral samples
- Performance Detection analyzes intervals, repeated notes, patterns, and speed
- Layer articulations for simultaneous crossfaded performances in one Preset
- Pre-configured patches for instant creation
- Prepared for future Multi Impulse Response Mixing and Reverberation Engine
- VST and Audio Units compatible



## EAST WEST

### Quantum Leap Goliath

Goliath includes the already huge 32GB's of content from Colossus and adds an additional 8GB's of new content to bring you an astounding 180 instruments and over 600 patches. This total sound set includes drums and percussion, guitars, basses, acoustic and electric pianos, keyboards and mallets, pop brass, orchestral instruments, choirs and vocals, ethnic instruments, new age ensembles, morphing atmospheres, synth basses, synth leads, and synth pads.

#EAEW176  
**\$625<sup>50</sup>**

- Massive sound library for almost any style
- Intuitive interface requires no learning curve
- 8GB of additional content expands versatility
- Includes a full version of Bosendorfer 290 Piano
- RTAS, VST, and Audio Units compatible



## BEST SERVICE

### Chris Hein Guitars

Christ Hein Guitars is a library of 40,000 samples comprising 18 GB of content with many variations of dynamics and articulations, often featuring 3000 to 6,000 samples per instrument. With the included Native Instruments Kontakt 2 player, all of the sounds are easy to navigate and control. You can achieve a customized natural performance with features like chord mode, slide mode (with hammer on/pull off), up and downstroke, and lots more.

#BEBS402  
**\$535<sup>50</sup>**

- The largest guitar library available
- Includes Kontakt 2 player
- Electric guitar clean, blues, chorus, metal
- Jazz guitar plectrum, fingered
- Banjo, mandolin, nylon, and steel guitars
- Reverb, chorus, delay, flanger, phaser, and filter included
- Mac and PC compatible



## EAST WEST

### Symphonic Orchestra Platinum Complete

This is a huge 4-volume, cross-platform 24-bit symphony orchestra sample library designed to work in all plug-in formats for professional use in film scoring, sound design and composition. The collection is over 67GB in size, and includes Native Instrument's Kontakt player, which functions as either a standalone or a plug-in for seamless DAW integration, and supports direct-from-disk streaming.

- 4-volume 24-bit symphonic sample library
- 256-voice polyphony, stand-alone or plug-in functionality
- High-quality samples recorded with natural concert hall ambience
- Programmable multi-mode filters, envelopes, LFO's for sound design
- Chorusing, delay and reverb effects
- Windows and Mac compatible

## SUBMERSIBLE MUSIC

### TerryPack I Drummerpack

The TerryPack I Drummerpack is a cross-platform plug-in collection of custom sounds fills and loops performed on his own custom kit by world-renowned drummer Terry Bozzio, fusing pop, fusion and progressive stylings with his truly amazing technical skill. The software is designed for seamless integration with Drumcore2 composing software for songwriters and producers.

#SUTP1DX  
**\$69<sup>99</sup>**



- Cross-platform sound and loop collection performed by Terry Bozzio
- Custom tom-toms and cymbals
- Completely editable grooves and fills
- Mac OS X and Windows XP/Vista compatibility

## SUBMERSIBLE MUSIC

### Upbeat and Aggressive Drummerpack

The Upbeat and Aggressive Drummerpack is a cross-platform plug-in collection of 1700 audio loops and matching drum kits suited for rock, metal and alternative music projects. The collection is designed for seamless integration with Submersible Music's DrumCore 2 drum composing software, and is arranged into 45-loop songwriting Groovesets offering the Loop Layer feature, which allows for custom multi-channel loops, fills and breakdowns.

#SUUADX  
**\$69<sup>99</sup>**



- Cross-platform loop and groove collection for rock, metal and alternative projects
- 25 MIDI drum kits based on 20 multi-velocity drum samples
- Intuitive interface designed for songwriters and composers
- Mac OS X and Windows XP/Vista compatibility



## IK MULTIMEDIA Sample Moog

#IKSM  
**\$249<sup>00</sup>**

This sample-based virtual instrument is an anthology of 16 classic modular and self-contained Moog synthesizers. Choose from the Modular 3C, Moog 15, Moog 55, Mini Model D, Polymoog, Taurus 1, Prodigy, Multimoog, Vocoder, Concertmate MG-1, Source, Rogue, Memorymoog, Theremin, the Voyager all the way up to the latest Moog, the Little Fatty. 1700 sounds in all powered and compatible with SampleTank, with over 50 synth controls and full MIDI control.

- Two synth engines with resampling and STRETCH
- Bases, leads, pads, plucked sounds
- Portamento control, multiple legato modes
- 32 built-in DSP effects with BPM sync
- 256 note polyphony
- Stand alone or VST, AU, or RTAS plug-in
- Mac and Windows compatible



## EAST WEST

### Quantum Leap Complete Composers Collection

This collection includes seven highly useful virtual instruments that are ideal for professional composition, and features a vast 130GB sound library to browse through. Each instrument is powerful in its own right, but when used together you will be able to approach any scoring situation with confidence. NI Kompakt provides a streamlined and logical user interface and is compatible with all major plugin formats.

#EAEW178  
**\$1075<sup>50</sup>**

- Quantum Leap Symphonic Orchestra Gold Complete
- Quantum Leap Symphonic Choirs
- Colossus super soft-sound module
- RA world and ethnic virtual instrument
- Stormdrum and Percussive Adventures 2
- Bosendorfer 290 Grand Piano



## EMU

### Proteus X2

#EMPX2  
**\$99<sup>99</sup>**

The Proteus X2 is a Windows-only software sound module containing over 3GB of sounds from the original Proteus, Morpheus and Mo'Phatt rackmount synths. The Proteus X2 software uses EMU's glistening 24-bit/192kHz sound engine, and offers extensive filtering and parameter control, real-time audio expansion/compression, and the Xmidi 2-in/2-out MIDI interface thrown in for the bargain.

- Windows-based software synth with stand-alone or VSTi operation
- 3GB of sounds from the Proteus, Morpheus and Mo'Phatt hardware modules
- 50 Z-plane filters, 100 tempo-based parameters for each preset
- Sound engine supports RAM and streaming playback modes
- Bus-powered USB 1.1 Xmidi interface included
- MME, CoreMIDI and DirectMusic support

## EAST WEST SD2

#EAEW175  
**\$445<sup>50</sup>**

SD2 percussion module is twice the size of the original Stormdrum, featuring over 12 Gigabytes of all new acoustic percussion instruments with both 64-bit and 24-bit support. Also included are over 100 film score oriented MIDI performances, each with dozens of variations, intros and endings from bombastic to hypnotic. Not only can you effortlessly change tempo of your performance but, with 24 velocity layers to work with, sound replacement and external triggering become attractive options.



- Both standard and unconventional percussion module
- Tempo change MIDI files without timestretching
- Deep velocity levels and alternate sample switching
- Convolution reverb and delay onboard
- Many unique percussion effects included

## BEST SERVICE

### Ethno World 4 Professional

#BEBS408  
**\$517<sup>50</sup>**

Ethno World 4 Professional is an extensive collection of world instrument samples, over 10GB in size containing over 200 instruments from all 6 continents, and more than 14,000 samples. The sounds have been culled from sessions supervised by film composer Marcel Bar-sotti, and the sample quality and detail reflects his professional knowledge and experience, for the benefit of film scorers and sound designers.



- Huge sample collection of world instruments supervised by film composer
- Bowed and plucked string instruments, woodwinds, percussion, mallets and bells
- Choirs and string ensembles with key switching
- All performances by professional players on their chosen instruments
- 1400 loops and phrases
- Micro-tuning, Time Machine II tempo control, Humanize Modus phrasing function





**YELLOW TOOLS**  
**Independence Pro**

#YEIP  
**\$499<sup>00</sup>**

Independence is a true sampling workstation that comes complete with a 70GB sound library and sophisticated search and import browser that lets you assign attributes to your files for quick and easy management. Culture is an Independence instrument that provides you with a huge selection of world, ethno, orchestral and industrial percussion captured with an amazing level of authenticity to create a truly playable instrument. Majestic gives you command of electric bass sounds like no other software instrument.

- Powerful sampling workstation environment
- Supports up to 8 cores and beyond
- Loads 3rd party VST effects and instruments
- Drag and drop both audio and MIDI files
- Pro surround capable up to 8.1

**Culture** *percussion instrument*  
#YECULTURE ..... **\$299.00**

**Majestic** *electric bass instrument*  
#YEMAJESTIC ..... **\$299.00**



**ARTURIA**  
**Brass**

#ARBRASS  
**\$299<sup>95</sup>**

Brass is a cross-platform physical modeling software plug-in or stand-alone virtual instrument specializing in uncanny emulations of the acoustic behavior of a saxophone, trumpet and trombone. The models are meant to be played by a MIDI keyboard or breath controller, and the great attention to nuance and exacting simulation of the control parameters provided allow for highly realistic, expressive performance possibilities.

- Physical modeling software program simulating sax, trumpet, and trombone
- Fully playable by MIDI keyboard or breath controller
- Eight real-time parameter controls include attack, pressure, vibrato and timbre
- Pitch control for falls, legatos and mute simulator for trumpet, trombone
- Over 500 editable cross-genre riff and phrase presets
- Reverb and chorus effects
- Windows XP and Mac OS X compatible



**BIG FISH AUDIO**  
**Addictive Drums**

#BIADD10  
**\$219<sup>95</sup>**

Addictive Drums features superior multi-mic samples, a full set of production tools and more than 3,000 built-in beats to get you up and running quickly, whether you are an experienced drum programmer or a songwriter looking to spice up your production. It can sound extremely realistic, producing true acoustic drums, but it can also be tweaked and manipulated into machine-like kits or weird rhythmic effects. Its user interface gives you instant access to every parameter and it is compatible with most major plugin formats.

- Complete drum production toolkit
- Contains over 3500 grooves and styles
- Adjust insert effects, reverbs, tunings, envelopes and mics
- Versatile selection of drum kits and cymbals
- AudioUnit, RTAS, and VST compatible

**YELLOW TOOLS**  
**Premium Suite**

#YEPREMIUM  
**\$999<sup>00</sup>**

Premium Suite includes the complete Yellow Tools product range in one package to serve as the ultimate bundle for music producers, film-composers, sound designers, songwriters and remixers. The package includes the full-featured Independence Pro Sample Workstation, saxophone instrument Candy, Culture for a world sampling of percussion, the Majestic bass instrument, and the Freedom virtual effects rack. With over 70GB of samples provided Independence alone, this kit is sure to offer options for almost any situation.



- Complete Yellow Tools collection in one package
- Independence Pro Sampler Workstation and Freedom effects rack
- Candy saxophone instrument offers multiple playing techniques
- Culture percussion instrument with right/left hand samples
- Majestic fretted and fretless electric bass instrument

**SUBMERSIBLE MUSIC**  
**Blues & Boogie Drummerpack**

#SUBBDX  
**\$69<sup>99</sup>**

The Blues & Boogie Drummerpack is a cross-platform plug-in collection of audio loops and MIDI kits suited for guitar based music projects in the blues, rock, and country vein. The collection is designed for seamless integration with Submersible Music's DrumCore 2 drum composing software, and offers a versatile collection of authentic shuffles, Groovesets, and straight 4/4 renditions delivered on a superbly and consistently recorded drum set.



- Cross-platform loop and groove collection for blues, country and rock projects
- High-quality audio content with MIDI kits based on DW drum set
- Authentic performances with 21 mix n' match Groovesets
- Mac OS X and Windows XP/Vista compatibility



## BIG FISH AUDIO Elite Orchestral Percussion

Elite Orchestral Percussion puts more than 250 categorized instrument patches under your fingertips. From chimes and cymbals to mallets and snare drums, this collection will help to fill out your percussion toolbox with 19GB of 24-bit samples complete with EZRoom ambient control for placing your selections in any one of over 50 different sonic spaces. A randomization engine helps to inject more realism into your performances, and articulations such as flams, 3-stroke ruffs, chokes, rolls, and realistic rhythmic patterns are easily achieved.

#BIEOP01  
**\$359<sup>95</sup>**

- Full collection of orchestral percussion with custom articulation
- Humanize engine randomizes pitch, tuning, and volume
- Receives up to 64 MIDI channels simultaneously
- Onscreen EQ and velocity setting controls
- Supports AudioUnit, VST, RTAS, and DXi plugin formats



## PERCUSSA AudioCube (4-Pack)

The AudioCube is a truly unique cross-platform USB/MIDI controller and low-fi sound generator. The unit comes with a set of software configuration patches and communicates wirelessly with other adjacent AudioCube units. The units control any MIDI-compatible hardware or software instrument or plug-in processors, creating exotic real-time performance effects not possible with any other device. The 1/4" I/O's allow the application of low-res, low-fi audio effects to external signals – the more AudioCubes, the more changes and effects settings.

#PEAC4  
**\$599<sup>48</sup>**

- Real-time USB 2.0 MIDI controller and 9-bit/32kHz low-fi effects generator
- Create continuous controller effects and commands by placement and hand motion
- Approx. 16" IR wireless communication range
- 1/4" phone audio input and output
- USB port and cable provided
- Mac and Windows compatible



## DIGIDESIGN Structure

#DISTRICTURE  
**\$499<sup>00</sup>**

Structure is a full-featured and reliable software sampler that has been designed and optimized exclusively for Pro Tools. It includes comprehensive, premium factory sound sets from East West and A.I.R., while allowing you to make use of your existing SampleCell, Kontakt, and EXS24 sound libraries. There are six freely assignable, context-dependent Smart Knobs to give you quick access to its most important sound sculpting parameters. Its powerful database and integrated file browser make finding and managing files a snap while its sound engine supports all common bit-depths, sample rates and surround formats.

- Professional sampler workstation for Pro Tools
- Unlimited number of nestable patches
- Up to 128-level multitimbral playback
- Drag-and-drop regions from within Pro Tools to sampler
- Streamlined interface for intuitive operation

## OCEAN WAY DRUMS Sampled Drum Kits

The list of top artists who have recorded in the Ocean Way recording complex is both long and star-studded. Ocean Way Drums brings these drum rooms right to you with a massive library of 19 kits, each with 12 presets in both snare on and snare off position. These have been recorded in some of the world's most revered rooms with the best possible sounding drums at the hand of top-notch producer/engineers. If you crave tweakability, individual instrument faders and stereo sub mixes can be adjusted for unlimited possibilities.



- High resolution drum recordings with natural ambience
- Flexible and intuitive keyboard positions for drum kits
- Includes individual and combination patches
- Produced in collaboration with Sonic Reality
- Includes convenient map for Roland V-Drum users

**40GB Gold Edition #OCDKGE ..... \$895.00**  
**80GB Platinum Edition #OCDKPE ..... \$1,795.00**

## DIGIDESIGN Strike

#DIS  
**\$299<sup>00</sup>**

Strike is a unique drum composition tool that behaves like a virtual drummer with its wide range of high-definition drum kits and styles to choose from. Create your own custom patterns or choose from over 1,500 editable presets to apply to one of the five high-resolution drum kits. After choosing a kit and style the only thing that you have to do is tell your virtual drummer how to play your parts by adjusting the intensity, complexity, timing, groove, dynamics and much more.



- Virtual drumming instrument for Pro Tools
- Easily produce highly realistic drum performances
- Full real-time control of your virtual drum performance
- Set mic placement and leakage with multi channel support
- Over 20GB of 24-bit audio losslessly compressed to 5GB of space

**ZOOM****H4 Podcasting Kit**

#ZOH4PCKW  
**\$429<sup>95</sup>**

The H4 Podcasting Everywhere Kit for Windows is basically a portable podcasting solution put together by B&H for field production and immediate distribution applications. The package features the Zoom Z4 portable SD recorder, an Audio Technica AT804 dynamic microphone with cable, a Quik-Lok A-188 desktop mic stand, and FeedForAll podcast recording and RSS distribution software.

- Portable 4-track SD recorder with built-in microphones
- Stereo or mono recording, XLR input for external mic
- 24-bit/96kHz recording resolution
- 2GB SD card included with 34 hours of MP3 recording
- High-quality dynamic microphone and cable included
- Professional headphones and desktop mic stand included
- FeedForAll podcast creation and RSS distribution software
- Windows XP only

**Mac version #ZOH4PCEKM.....\$429.95**

**SAMSON****C01U Recording Pak**

The C01U Recording Pak is a low-cost podcast solution for direct-to-computer podcast recording via the digital C01U condenser microphone



#SAC01UPK  
**\$169<sup>00</sup>**

equipped with a USB output. The package is further equipped with a shockmount, microphone clip and aluminum case, a desktop microphone stand, a USB cable, and Windows-only Sonar LE software for multi-track recording and editing.

- Unique digital condenser microphone with USB output
- Professional shock mount and desktop mic stand included
- Aluminum carrying case for microphone
- Direct recording to computer • Windows XP only
- Internal mic shockmount minimizes vibration, rumble
- Shockmount and desktop mic stand included
- Sonar LE multi-track audio production software

**Mac version #ZOH4PCEKM**

**SOUND IDEAS****Podcasting Production Toolkit**

#SOPCTK  
**\$99<sup>00</sup>**

The Podcasting Production Toolkit is a 3-section collection of over 1000 MP3 files presented in a clean 128kbps file format divided into Royalty-Free Music, Production Elements and Sound Effects folders. It's a versatile, inexpensive solution for producing a polished, professional Podcast presentation.

- Over 1000 MP3 files in 128kbps file format divided into 3 folders
- Royalty-Free Music Folder with over 40 one-minute tracks from 15 genres
- Production Elements Folder with 189 elements in 7 sub-folders
- Sound Effects Folder with 770 effects in 23 categories

**BEHRINGER****Podcastudio Firewire**

#BEPCSFV  
**\$179<sup>99</sup>**

The PODCASTUDIO FIREWIRE is a complete low-cost package for creating podcasts right from the desktop. The kit includes the XENYX 802 8-channel mixer, the C-1 large-diaphragm condenser microphone, the FCA202 Firewire interface, HPS3000 headphones, and Ableton Live Lite 4 multi-track audio recording and editing software. Firewire and microphone cables and a desktop mic stand are also included.



- 8-input/2-bus mixer with dual 48V mic preamps
- 24-bit/96kHz 2-in/2-out Firewire interface
- 3-band EQ per mixer channel
- Large-diaphragm condenser microphone with cable and stand
- 4 1/4" cables, 2 Firewire cables
- Headphones, carrying case, and Cubase LE software included
- Software includes Audacity, Kristal Audio, and Ableton Live Lite 4
- Mac OSX and Windows XP compatible

**Also available PODCASTUDIO USB #BEPCSUSB.....\$99.99**

**B&H****Podcasting Kit - Mac**

#BHPKM  
**\$259<sup>00</sup>**

The Podcasting Package for Mac OSX is a software-driven bundle dedicated to creating and producing podcast content. The kit includes the Samson C01U digital condenser microphone and SP01 shockmount, high-quality Audio Technica ATH-M2X headphones, a rugged On-Stage DS7200B desktop mic stand, and abundant software featuring Bias Peak LE 5 for optimized Web audio recording and editing.

- Digital condenser microphone with USB connection
- Direct recording to computer, no mixer necessary
- Professional shock mount and desktop mic stand included
- Professional headphones for monitoring, mixing
- Bias Peak LE 5 software for Web-optimized audio recording
- Sound Ideas Captain Audio sound FX CD for podcasting and presentations
- FeedForAll podcast creation and RSS distribution software
- Mac OSX only



**Windows version #BHPKW.....\$259.00**



## ALESIS iMultiMix 9R

#ALIMM9R  
**\$299<sup>00</sup>**



The iMultiMix 9R is a 9-channel rack mount mic/line mixer featuring an iPod docking station with video and audio iPod support. A video output for the video iPods endows the mixer with full A/V playback capability. There are nine channels with 1/4" TRS connectors, five phantom-powered XLR microphone preamps, and two stereo channels. The iMultiMix 9R is a versatile solution for educational, podcasting, and exhibition audio applications.

- 9-channel mic/line mixer with iPod dock
- 3-band EQ section per channel
- (2) Aux sends, stereo return
- (5) mic preamps with phantom power
- 1/4" TRS Main Out, RCA Video Out

## ALESIS iMultiMix 8 USB

#ALIMM8USB  
**\$299<sup>00</sup>**



The iMultiMix 8 USB is a compact 8-channel recording or live sound mixer with internal effects processing, an iPod dock, and a 24-bit/96kHz multi-channel USB port. Featuring 4 mono and two stereo-paired line inputs and four phantom-powered mic preamps, this flexible mixer also provides 3-band and a post-fader aux/effects send on each channel. The unit is an excellent desktop solution for Podcasting, personal DAW recording, and small-venue sound reinforcement.

- 8-channel desktop mixer with iPod dock
- (4) XLR mic preamps with phantom power
- Direct iPod record/playback, PC or Mac iTunes file transfer
- 100 internal multi-effects
- Hi-res USB connection, Cubase LE software included
- Separate control room out with level control

## MXL Desktop Recording Kit

#MXMXLDRKM  
**\$138<sup>95</sup>**



The MXL Desktop Recording Kit is a podcast production package designed for home and multimedia studio desktop use. The kit includes a 9V battery-powered cardioid condenser microphone, a desktop stand, mic clip, and cables, and the custom Apple Mac iBooster in-line preamp, allowing for direct connection to an Apple computer via the standard 1/8" line-level input connector.

- Desktop podcast and voice-over audio production solution
- Battery-operated cardioid condenser microphone
- iBooster in-line mic preamp for direct Mac connection
- Tight mic pick-up pattern for enhanced speech clarity, bass response
- XLR, XLR-1/8" mini, 1/8" - 1/4" phone adapter included
- Storage case and recording guide included

## ALESIS USB-Microphone Podcasting Kit

#ALUPCMK  
**\$99<sup>00</sup>**

The USB-Microphone Podcasting Kit is a solution for creating and distributing CD-quality podcast content right from the desktop. The Alesis Podcast dynamic microphone connects directly to the computer via a USB output, and the included Cubase LE software allows for high-quality, cross-platform audio recording, mixing and editing. The kit also includes 30 days of free podcast posting on alesispodcast.com for immediate user gratification.



- High-quality USB microphone with USB output
- Desktop microphone stand and cable included
- 16-bit/44.1/48kHz recording resolution
- Cubase LE and Audacity recording software
- Headphones included for monitoring and mixing and Cubase LE software included
- Up to 500MB posting free on alesispodcast.com for 30 days
- Mac OSX and Windows XP compatible

## NOTEPAGE Feed For All

#FEFFAM  
**\$49<sup>95</sup>**



FeedForAll is a slick, easy-to-use podcasting and RSS/iTunes distribution software program for Mac OSX. Podcast content creation and publishing is aided by help wizards for novices, while advanced users may manually input RSS tags at will. The program offers full support for the RSS namespaces and extensions used on iTunes, allowing for podcast publishing with direct iTunes access.

- Intuitive podcast content creation and distribution
- Manual input for advanced users
- iTunes RSS namespace and extension support
- WYSIWYG help wizards for novices
- Mac OSX only

**Windows version #FEFFAW .....\$49.95**

**NOVATION**  
**X-Station 25**

#NOXS25  
**\$499<sup>99</sup>**

The Novation X-Station 25 is a revolutionary synthesizer/controller with built-in audio and MIDI interfaces, zero-latency internal digital effects, and powerful controls and templates for complete control of popular software synthesizers. With all audio and MIDI information being run down one single USB cable, the unit is extremely portable, ideal for mobile production, and remotely powered by batteries or USB.

- 25-keys semi-weighted with aftertouch
- Virtual synthesizer control panel layout for plug-ins and software, with all controllers fully assignable
- Built-in 8-Voice polyphonic synth • 24-bit/44.1-48kHz simultaneous 2-channel audio I/O and digital S/PDIF output • Dual low-noise preamps with phantom power on Neutrik combo XLR jacks
- Multi-fx processor with up to 6 effects per input
- Powered via: USB, batteries or 9V power supply



**X-Station 49** 49-key version of X-Station 25 #NOXS49..... **\$549.99**  
**X-Station 61** 61-key version of X-Station 25 #NOXS61..... **\$599.99**



**NOVATION**  
**XioSynth**

The XioSynth combines an 8-voice synthesizer, high-quality audio interface, and flexible USB MIDI controller into one powerful keyboard. The subtractive synth engine boasts an arpeggiator, multi-effects and 200 distinctive patches from a variety of musical genres. The 2in/2out audio interface allows simultaneous recording of external and internal sources. And finally, the 16 built-in templates and comprehensive control surface deliver instant feedback and control of many current software applications.

**XIOSYNTH25** 25-key version #NOX25 ... **\$299.99**  
**XIOSYNTH49** 49-key version #NOX49 ... **\$399.99**

- Mono, 8-voice synth/controller with built-in USB audio interface • 3 OSC's with 17 waveforms, 2 LFO's with 32 waveforms • 16 onboard templates for software control
- (11) knobs and switches, pitch/mod lever, X/Y touchpad • (1) XLR and 1/4" input jack

**NOVATION**  
**Remote SL 25**

#NOR25SL  
**\$399<sup>99</sup>**

The Remote SL 25 is a 25-key MIDI controller that combines extensive hands-on control with two large back-lit LCD screens capable of displaying 16 parameter names and values simultaneously. Thirty-nine Template Memories are designed to work with software applications, virtual instruments, and external MIDI equipment while the remaining template (Automap) intelligently maps the supported application and all active components within the session to itself; a truly revolutionary controller.

- 25-key MIDI controller with software/instrument templates including Automap feature
- Assignable X/Y touchpad, joystick and a total of 56 encoders, pots, sliders, and buttons
- (2) bright, back-lit 144-character LCD's
- Dedicated transport controls
- USB connection



**YAMAHA**  
**KX25**

#YAKX25  
**\$299<sup>99</sup>**

Yamaha's KX8 is a 25-key USB/MIDI controller keyboard featuring a built-in Arpeggiator with over 500 selectable phrases and a library of drum, guitar, bass and other musical phrases for quick composition.



Designed with the software music production environment and workflow in mind, the KX25 controls and transports are optimized for seamless DAW software and virtual instrument compatibility, including recording, programming, navigating and performance functions.

- 25-key USB/MIDI controller keyboard with GHS technology and Initial Touch • Built-in control templates for 30 different software instruments • Pitch and Modulation Wheels, (4) assignable encoder knobs, (37) panel switches • Mac OS X, Windows Vista/XP compatible

**KX49** 49-key version #YAKX49..... **\$349.00**  
**KX61** 61-key version #YAKX61..... **\$399.00**

**M-AUDIO**  
**Axiom**

#MAA25  
**\$179<sup>00</sup>**

The Axiom is a 25-key velocity-sensitive keyboard with aftertouch. It features 8 trigger pads that are ideal for drum programming and loop triggering, 8 rotary encoders and 6 re-assignable transport buttons.



The unit is USB bus-powered and contains 20 non-volatile locations for custom setups. Ableton Live Lite 4 and the Enigma editor/librarian are both included for production and controller assignment.

- 25-key velocity-sensitive USB/MIDI controller with aftertouch
- (8) trigger pads, (8) rotary encoders, (6) transport buttons, pitch and mod wheels • Dedicated transpose and octave buttons
- Windows XP and MAC OS X compliant

**Axiom49** 49-key version with additional assignable sliders and buttons #MAA49..... **\$249.00**  
**Axiom61** 61-key version of above #MAA61..... **\$299.00**

## EDIROL PCR-300

#EDPCR300  
**\$249<sup>00</sup>**

The PCR-300 is a compact 32-Key Velocity-Sensitive USB/MIDI controller keyboard with an extensive array of assignable real-time knobs, faders, and buttons. This updated version of the popular PCR-3 features a newly designed key mechanism, selectable velocity curves, and a redesigned pitch/modulation controller. Its wide variety of real-time controllers are ideal for adjusting sequencer and virtual instrument parameters.

- (8) Knobs, (8) Faders and (9) switches, and (2) pedal ports
- (12) selectable Velocity Curves, and a Fixed Velocity mode
- Octave Shift and Transpose buttons
- USB bus-powered or AC adapter (included)
- Mac and Windows compatible



**PCR-500** 49-key version #EDPCR500 ..... **\$299.00**  
**PCR-800** 61-key version #EDPCR800..... **\$349.00**



## BEHRINGER UMX49

#BEUMX49  
**\$129<sup>99</sup>**

The UMX49 from Behringer is a portable USB keyboard controller kit that includes a USB audio interface for a computer, virtual instruments, and Ableton Live production software. The keyboard controller allows you to play software instruments. The audio interface allows you to connect to a sound system, or to record audio into the included Ableton Live software. It's a complete digital audio bundle to enter the world of digital audio.

- Includes 50 virtual instruments (pianos, synths, samplers, etc.)
- USB Audio interface included
- Ableton Live Lite included
- 49 velocity sensitive keys
- (8) user defined buttons
- (10) assignable MIDI controls

## NOVATION Remote ZeRO SL

#NORZSL  
**\$299<sup>99</sup>**

The Remote ZeRO SL is an intelligent control surface that detects what instruments you have in your project and intelligently maps the controls to its front panel. Running along the top of its front panel are two 144-character screens, which can display up to 16 parameter names and values simultaneously. The ZeRO is an excellent addition to any DAW providing plenty of tactile access to your software with an expressive X/Y touchpad, dedicated transport controls and 8 musically-responsive trigger pads.

- Intelligent MIDI control surface
- (2) giant, brightly-lit LCD screens
- (8) rotary pots, (8) sliders, (8) rotary encoders and (24) switches
- Automap supported by most major music programs
- Total portability with battery operation



## M-AUDIO KeyStudio 49i

#MAKS49I  
**\$249<sup>00</sup>**



The KeyStudio 49i is a dual-function bus-powered 49-key controller keyboard and 2-in/2-out USB audio interface. The unit features an internal stereo-sampled Steinway Grand piano sound that may be played as a stand-alone instrument. The keyboard is bundled with a General Music software sound module and Ableton Live Lite audio recording software, adding expanded functionality as a desktop music production package.

- 49-key USB/MIDI controller keyboard
- Built-in sampled Steinway Grand piano with 20-voice polyphony
- General Music software sound Module with 128 programs
- Pitch and Modulation Wheels, (4) assignable rotary controls, (5) assignable switches
- XLR microphone and 1/4" TS phone instrument inputs
- (2) 1/4" TS phone, (2) RCA phono line outputs
- USB I/O, MIDI output, (2) 1/4" TRS headphone outputs
- Mac OS X and Windows XP/Vista compatible

## M-AUDIO MidAir

#MAMAQ  
**\$119<sup>00</sup>**

The MidAir is a single-channel wireless MIDI system complete with a battery-powered transmitter, and a USB bus-powered receiver that also functions as a stand-alone MIDI interface. The system transmits data from any MIDI device for distances of up to 30 feet in the 2.4GHz frequency range. The MidAir is an effective stage solution, creating greater mobility for musicians and engineers.



- Single-channel wireless MIDI system for stage
- 2.4GHz frequency transmission
- Works with any MIDI device, from keyboard to lighting rig
- Bus-powered or AA battery power
- Mac and Windows compatible



**E-MU**  
**Xboard 25**

#EMXB25  
**\$129<sup>99</sup>**

The Xboard 25 is a 25-key MIDI keyboard controller featuring a high-quality synth action with velocity-sensitive keys and aftertouch. Xboard Control software allows the creation of custom templates for assigning the 16 real-time control knobs to both hardware and software instruments. Drum loops are easily controlled by defining a section of the keyboard as on/off triggers in the unique "Latch Mode."

- 25-key MIDI controller with velocity-sensitive keys and aftertouch
- 16 fully-assignable real-time control knobs
- Unique "Latch Mode" for triggering drum loops
- Includes Proteus X LE sound module with over 1000 presets and Ableton Live Lite 4 (Win)
- USB-, battery- or AC-powered
- Windows 2000, XP and Mac OS X drivers



**Xboard49** 49-key version of above #EMXB49 ..... **\$169.99**



**M-AUDIO**  
**Oxygen 8 v2**

#MA08V2  
**\$119<sup>00</sup>**

The Oxygen 8 v2 is a compact 25-key USB/MIDI controller featuring 8 fully-assignable MIDI controller knobs, 6 transport buttons, 5 dedicated function buttons, and 10 non-volatile memory locations. It's an ideal mobile solution for triggering samples, visual effects, or performing basslines and pads.

- 25-key MIDI controller with velocity-sensitive keys
- Full MIDI-message support and compatibility to Enigma editor/librarian
- (8) knobs and (6) transport buttons (assignable), (5) dedicated function buttons
- Ableton Live Lite 4 included
- LCD screen

**Oxygen49** 49-key version with 35 controllers including faders #MAO49 ..... **\$139.00**  
**Oxygen61** 61-key version of above #MAO61 ..... **\$169.00**

**CME**  
**VX6**

#CMVX6  
**\$799<sup>99</sup>**

The VX6 is a unique master keyboard that goes well beyond the feature set of a simple controller and gives you complete access to your entire recording and performing environment. It supplies both USB MIDI and USB audio functions eliminating the need for a separate sound card and MIDI interface. The VX supplies loads of hands-on controllers including motorized faders, trigger pads, a ribbon controller, SEQ transport buttons, and pedal inputs. The unit's multi-function expansion slot gives you the option for future growth with the proposed addition of a sound module/sampler, analog synthesizer module, firewire audio interface module, digital mixing module and more.

- 61-note MIDI controller with USB audio and aftertouch
- (9) 60mm motorized fader controllers
- Alternate scales to better suit ethnic music
- Music software control templates with user bank memories
- Firmware upgradeable via USB



**VX5** 49-note semi-weighted version of above #CMVX5 ..... **\$699.99**  
**VX7** 76-note semi-weighted version of above #CMVX7 ..... **\$899.99**  
**VX8** 88-note fully-weighted version of above #CMVX8 ..... **\$999.99**

**CME**  
**Bitstream3X**

#CMB3X  
**\$399<sup>00</sup>**

The Bitstream3X is a tactile control surface that features full control over 3 different Axes, with a joystick allowing control over the X and Y while a ribbon controller is used for the Z Axis. With 35 knobs, 8 Sliders, and 16 buttons, the Bitstream3X gives you total hands-on control of any DAW software and comes with an astounding 13,000 presets including Reason, Live, Reaktor, Traktor, Absynth, Cakewalk, and of course, Cubase. Digital DJ's will love the MIDI Cross fader and the 8 track motion sampler allows automated recording of the movements of the knobs, joystick, crossfader, and ribbon controller.



- Hands-on USB compatible MIDI control surface
- (35) knobs, (8) sliders and (16) buttons including transport
- 8 track-motion sampler for recording all controls
- Enhanced arpeggiator and built-in programmable LFO
- 13,000 Presets for a huge variety of synths and software

**CME**  
**UF50**

#CMUF50  
**\$329<sup>00</sup>**

The UF50 is a robust 49-key controller keyboard housed in a high-tech, rugged aluminum casing, designed for mobile recording and performance applications. The unit features a WIDI-XU wireless MIDI interface with line-of-sight RF transmission capabilities of over several hundred feet.



- 49-key USB/MIDI controller keyboard with Aftertouch
- Built-in full-duplexing wireless MIDI interface with 64 selectable radio channels
- Pitch and Modulation Wheels, (8) assignable rotary controls, (9) faders
- Sustain pedal, controller pedal and breathe controller inputs
- Mac OS X and Windows XP compatible

**UF60** 61-key version #CMUF60 ..... **\$379.00**  
**UF70** 76-key version #CMUF70 ..... **\$469.00**  
**UF80** 88-key version #CMUF80 ..... **\$649.00**  
**UF400E** FireWire expansion card #CMUF400E ..... **\$199.00**

**M-AUDIO****KEYSTATION PRO88**#MAK88P  
**\$399<sup>00</sup>**

The M-Audio Keystation Pro88 is an expressive velocity-sensitive 88-key Hammer Action USB Midi Controller that provides 59 different controllers ideally suited for computer-based programming, mixing, and performing. This powerful controller gives users full command of their virtual synths and digital audio sequencers.

- Assignable controllers include: (24) knobs, (22) buttons, (9) faders, (2) wheels and pedals
- Large custom LCD screens controller name, number, and edit value
- 4-zone split/layer functionality
- 10-memory locations for storing controller settings
- Mac and PC compatible

**YAMAHA****KX8**#YAKX8  
**\$699<sup>99</sup>**

Yamaha's KX8 is an 88-key controller keyboard USB/MIDI controller keyboard featuring a built-in Arpeggiator with 342 selectable types and a library of drum, guitar, bass and other musical phrases for quick composition. Designed with the software music production environment and workflow in mind, the KX8 controls and transports are optimized for seamless DAW software and virtual instrument compatibility, including recording, programming, navigating and performance functions.

**KX25** 25-key version #YAKX25 ..... **\$299.99**

- 88-key USB/MIDI controller keyboard with GHS technology and Initial Touch
- Built-in Arpeggiator with 342 types
- Built-in musical instrument phrase library for quick composition/accompaniment
- Built-in control templates for 30 different software instruments
- Pitch and Modulation Wheels, (4) assignable encoder knobs, (37) panel switches
- USB or AC power
- Cubase AI4 software supplied

**ARTURIA****Analog Factory Experience**#ARAFEX  
**\$299<sup>00</sup>**

The Analog Factory Experience is a unique, uniquely affordable hardware/software solution comprised of a 32-note keyboard controller and a software package containing a collection of 3500 classic analog synthesizers of yore. Musicians, sound designers and hardcore programmers can feast on presets culled from venerable Moogs, Prophets, ARPS and Jupiters for days while stirring the pot with a full-featured, highly-playable micro-controller.

- 32-key USB/MIDI controller keyboard with velocity sensitivity
- Software synthesizer collection with 3500 classic analog sounds
- Pitch Bend and Modulation wheels, clickable encoder
- (10) rotary encoders, (11) switches, (4) sliders
- Hold, Sustain, Expression pedal inputs
- Fully programmable vintage software synths with organized parameter presets
- Fast access filtering by Instrument, Type or Characteristics
- Mac OS X and Windows XP/Vista compatible

**LINE 6****TonePort KB37**#LITPKB37  
**\$299<sup>99</sup>**

The TonePort KB37 is a hybrid, self-contained, computer recording tool, combining a bus-powered 37-key USB/MIDI controller keyboard, and an audio interface with analog and digital connectors, level controls, and VU meters. The unit ships with Gearbox vocal- and guitar-oriented sound modeling software, along with a custom version of Ableton's Live MIDI and audio recording program.



- 37 velocity-sensitive keys
- Pitch-bend and modulation wheels, transport controls, patch-select buttons
- (4) assignable control knobs, (4) assignable buttons
- (2) XLR mic pres with phantom power
- (2) 1/4" TRS phone line, Hi-Z instrument, 1/4" TRS Monitor inputs
- 1/4" TRS Headphone, coaxial SPDIF, (2) 1/4" TRS Main outputs
- Mac OSX and Windows XP compatible

**AKAI****MPK49**#AKMPK49  
**\$399<sup>00</sup>**

The MPK49 is a portable 49-key USB/MIDI performance controller keyboard featuring a set of 12 tactile rubber MPC-type percussion pads and an arpeggiator. The pads offer the popular MPC-series Note-repeat and Swing functions, and a total of 48 pads may be accessed via a 4-bank assignment. The control surface is packed with 8 assignable sliders, 8 full-rotation control knobs, and a large bright LCD screen.



- Portable 49-key controller keyboard with semi-weighted keys and Aftertouch
- 12 MPC-type percussion pads with 4 banks
- 8 full-sized knobs with 3 banks
- 8 assignable sliders with 3 banks
- 8 assignable back-lit switches with 3 banks
- MMC/MIDI Stop/Start transport buttons
- Live performance or Studio DAW applications

**M-AUDIO****Trigger Finger**

The Trigger Finger is a sixteen pad MIDI/USB drum control surface designed for drum programming, triggering lops and samples, or generating MIDI controller information for any application. Its velocity-sensitive pads enable expressive performances keyboard controllers can't provide, and its full programmability enables users to customize the Trigger Finger to fit a variety needs.

#MATF  
**\$149<sup>00</sup>**

- (16) Uvelocity and pressure-sensitive pads, (8) assignable knobs, and (4) assignable faders
- Powered via USB or optional DC power supply
- Includes Ableton Live Lite 4 software
- Windows XP and Mac OS X

**ALESIS  
Control Pad**

The Control Pad USB/MIDI Percussion Controller is a compact percussion pad controller that is equally at home as a performance instrument and as a MIDI programming tool for studio recording. It features 8 velocity sensitive pads with gum rubber surfaces for excellent stick response as well as two trigger inputs for connecting external pads such as the Alesis Drum Pad and Cymbal Pad expansion kits. Further, there are two switch-pedal inputs to accommodate open and closed hi-hat as well as kick drum.

#ALCP  
**\$199<sup>00</sup>**

- USB bus powered drum control surface
- Pad sensitivity adjustment
- Stores MIDI setups with program change compatibility
- MIDI in and out with USB Plug-and-Play connectivity
- Power adapter included for use without computer

**Pad Trigger** external pad trigger

#ALPT ..... **\$49.00**

**Cymbal Trigger** external cymbal trigger

#ALCT ..... **\$49.00**

**AKAI  
MPD24**

The MPD24 is a velocity sensitive pad controller for musicians and DJ's working with sampled sounds. The MPD24 features 16 MPC-style velocity and pressure-sensitive pads plus transport controls for interfacing with DAW/sequencing applications. With Akai's MPC 16 Levels and Full Level features for ultimate pad control, four selectable pad banks totaling 64 pads, six assignable faders and eight assignable, 360-degree knobs for transmitting MIDI Control Change data, the MPD24 provides unprecedented creative freedom for manipulating sampled material. It is equally at home on stage or in the studio.

#AKMPD24  
**\$199<sup>00</sup>**

- MPC style drum pad controller
- (16) velocity- and pressure-sensitive pads
- (6) assignable faders for transmitting MIDI Control Change data
- (8) assignable 360-degree knobs
- Back-lit, easy to read LCD screen

**KORG  
padKontrol**

The padKontrol is an expressive and versatile 16-pad controller designed to produce natural sounding drumbeats. It combines an assignable X-Y touchpad for natural-sounding flams and rolls, 16 great-feeling illuminated trigger pads with 8 dynamic velocity curves, 2 assignable knobs and a footpedal input. It can not only access drum sounds and samples, but also control soft synths, effects, trigger video clips, and even be a transport control for DAW programs.

#KOPADKONTROL  
**\$199<sup>00</sup>**

- 16-pad controller with selectable velocity and dynamic ranges
- Ideal for creative drum programming and control
- Illuminated pads visually display control value status
- 30 built-in software templates and 16 User Scene memories
- Included Superior drum kit plug-in provides 260Mb of multiple-velocity samples
- Included Creative Kontrol Pack 2 features Reason Adapted 3.0, Live Lite 4, and more

**AKAI  
MPD 16**

The MPD16 is a dedicated pad controller that can be used with any sampler/sound module to record percussion tracks with the expression and feel that only pads afford. 16 pads, based on the famous MPC, provide velocity and pressure programming of percussion tracks over two banks. The continuous controller slider is capable of hi-hat or other sample switching and can help you set the feel for each individual pad.

#AKMPD16  
**\$99<sup>00</sup>**

- 16-pad MIDI controller designed for rhythm programming
- (2) switchable banks for a total of (32) assignable pads
- MPC's 16-levels and Full level features
- Pads can have assignable notes with variable velocity range
- MIDI and USB operation/power





**JAZZMUTANT****Lemur**

The Lemur is a live performance touch-screen software control surface packaged with the cross-platform JazzEditor programming application. The controller features a 12" screen and communicates via Ethernet using the Open Sound Control protocol, enabling complete software adjustment of parameters from fader movement to rotary and transport control, in a drag-and drop Object environment. All Object edits may be labeled, saved, and stored for instant recall.

#JAL  
**\$2999<sup>00</sup>**

- Touch-screen live performance control interface
- 12" high-resolution LCD screen
- Software creation and control of multiple custom control interfaces
- Drag-and-drop Object control of faders, switches, rotary knobs and more
- Open Sound Control protocol with Ethernet communication
- Mac OSX and Windows XP compatible

**DIGIDESIGN**  
**Command|8**

The Command|8 is a USB tactile control surface for Pro Tools TDM and LE systems, with additional native support for Avid products, including Avid Media Composer. Equally well-suited for both music and post-production studios, the Command|8 features 8 bankable channels of touch-sensitive motorized faders, 8 rotary encoders, transport control, and a flexible "Focusrite" onboard monitoring section.

#DICM8  
**\$1149<sup>00</sup>**

- Integrated (1) In (2) Out MIDI interface
- Stand-alone MIDI controller mode
- Large, 110-character back-lit LCD screen
- May be used in conjunction with ProControl, Control|24, and Digi 002
- Compatible with Windows XP and Mac OS X

**MACKIE****Control Universal Pro**

The Mackie Control Universal Pro is a handsome, compact AC-powered USB/MIDI control surface with 9 faders and a bright back-lit display. The unit is packed with ergonomically-presented rotary and transport controls, a large jog/shuttle wheel, and shows SMPTE Time Code read-out. The controller supports all the major cross-platform software DAW's on the market, and multi-unit operation is seamless.

- 9-fader touch-sensitive USB/MIDI DAW control surface
- High-quality optical Penny + Giles 100mm motorized faders
- Tape-style transport controls, multi-function rotary encoders
- Mute, solo, pan, send-level, record-arm control
- Cut, copy, and paste edit control
- On-board 4-channel USB MIDI interface
- Mac and PC compatible

#MAMCUPRO  
**\$1299<sup>99</sup>**

**EUPHONIX**  
**MC Control**

#EUMCCONTROL  
**\$1499<sup>99</sup>**



The MC Control is an advanced Mac-only DAW control surface from one of the world's elite automated mixing console manufacturers, ensconced in a sleek ergonomic chassis that connects to the computer via an Ethernet interface. The modular unit is expandable, and features a customizable touch-screen, touch-sensitive motorized faders and rotary encoders, selectable record/automation keys, and control room monitoring level control.

- Remote DAW control surface with Ethernet connection
- Touch-screen interface with dedicated tracks, soft keys and setup screens
- (4) touch-sensitive motorized faders
- (8) touch-sensitive rotary encoders
- Transport controls and jog/shuttle/zoom wheel
- Native support from high-end Mac DAW's for EuCon protocol

**EUPHONIX**  
**MC Mix**

#JCMCS3800W  
**\$999<sup>99</sup>**



The MC Mix is a modular, expandable DAW control surface for the Mac. It features EuCon Ethernet computer integration enabling lightning-fast access to pan, volume, EQ and plug-in parameter controls enhanced by hi-res metering and information displays. The unit sports touch-sensitive motorized faders and rotary encoders, an ultra-sleek footprint, an ergonomic work surface, and includes attachable desktop riser brackets.

- Sleek, modular Ethernet DAW control surface
- (8) touch-sensitive motorized faders
- (8) touch-sensitive rotary encoders
- Integrated solo/mute/transport keys
- Record/Automation keys, track navigation and channel display
- Native support from high-end Mac DAW's for EuCon protocol

## BEHRINGER BCF2000

The versatile BCF2000 is a configurable USB/MIDI surface controller featuring 8 motorized faders, 20 fully-assignable illuminated buttons, and 8 dual-mode high-resolution rotary encoders with LED rings and additional push function. Designed for easy setup and control of virtual mixers, synths, and samplers, the BCF2000 provides computer based studio musicians the analog feel, automation, and control of larger mixers for every software screen.

#BEBCF2000  
**\$199<sup>99</sup>**

- (8) motorized faders, (20) buttons, and (8) rotary encoders
- 32 user presets each with 4 encoder groups
- Controls assignable manually or via user-friendly learn mode
- Generic USB/MIDI support for Windows XP and Mac OS X



## BEHRINGER BCR2000

Designed for both studio and live use, the BCR2000 is a flexible USB/MIDI surface controller loaded with fully-assignable rotary encoders and switches. Its solid feel and ease of use make multiple parameter control of effects, mixers, and soft-synths a breeze. Create music more efficiently by dedicating specific knobs to control your most frequently used parameters, effectively reducing time-spent digging around for settings.

#BEBCR2000  
**\$129<sup>99</sup>**

- (24) high-resolution rotary encoders with LED rings, (20) freely assignable buttons, (8) dual-mode rotary encoders with LED's and push-assign function
- Controls assignable manually or via user-friendly learn mode
- Configurable MIDI and USB modes for flexible system integration
- (1) MIDI in (2) MIDI outs for additional external hardware control
- Rugged, durable construction
- Generic USB/MIDI support for Windows XP and Mac OS X

## MACKIE Control C4 Pro

The Control C4 Pro is a MIDI software control surface with 32 V-pots and 4 large back-lit displays, providing simultaneous control of up to 32 plug-in and virtual instrument parameters without switching banks. Dedicated function buttons beneath the screens and controls allow the user software parameter arrangement identical with that on the computer monitor for immediate, intuitive control.

#MAMCC4PRO  
**\$1099<sup>99</sup>**

- Real-time plug-in/virtual instrument control surface
- 32 V-pot control knobs for 32-simultaneous parameter control
- LED pot rings for precise settings
- 4 back-lit LCD screens for immediate monitoring of settings
- Seamless integration with Logic, Sonar, Reason, and Traktion
- Mac and Windows compatible



## M-AUDIO UC-33E

UC-33e is an affordable USB/MIDI hardware controller with 47 user-configurable controls in a compact tabletop design. The intuitive layout of

Knobs, Faders, and Buttons can be assigned to control parameters of virtual Instruments, plug-ins, and host applications.

- (24) fully-assignable knobs
- (9) full-size, assignable ALPS faders with light indicators
- (14) assignable buttons for control of sequencer functions
- Drawbar mode for control of classic organ emulators
- 33 memory settings for storing your settings
- Includes color overlays for Pro-53, B4, Ableton Live, Cubase, and Logic



#MAUC33E  
**\$179<sup>95</sup>**

## M-AUDIO iControl

iControl is a tactile control surface for Apple's GarageBand audio software. Its straightforward design provides a simple button push to cycle through each bank of 8 tracks each. 8 endless rotary knobs, mode buttons, solo, mute and record-enable buttons, and a dedicated transport and jog wheel that provides immediate user playback and record control.

- Designed for use with Apple's GarageBand
- Control track volume, pan position, effects and EQ
- Intuitive single-button cycling through each bank of tracks
- Single master fader, banking switches, model selection switches
- (8) endless assignable rotary knobs
- USB connection



#MAIC  
**\$99<sup>00</sup>**

**FRONTEIR DESIGN GROUP****Tranzport**

The Tranzport is a compact wireless remote control for digital audio workstations that uses high-frequency radio waves (RF) to send and receive control data, and uses advanced coding and frequency-hopping techniques to operate with minimum interference. Requiring only one USB port for the small receiver, the Tranzport allows users to arm tracks, use transport controls, set markers, control pans, punch in/out, and start loops remotely.

#FRT  
**\$199<sup>00</sup>**

- Dedicated buttons for: transport controls, marker/locate, track control (level, pan, solo, mute, arming)
- Two-way interface: provides timecode position, track name/number, track volume, pan setting
- Compatible with Windows 2000, XP and Mac OS X

**FRONTIER DESIGN  
AlphaTrack**

The AlphaTrack is a compact USB control surface equipped with a 100mm touch-sensitive motorized fader, transport control, three touch-sensitive encoders, and an innovative touch-sensitive jog and shuttle strip for fast timeline control. This cross-platform DAW controller also has a set of 22 buttons & 21 LED's for track-specific and global functions. A 32-character back-lit display provides users with context-specific feedback in real time.

#FRATC  
**\$199<sup>00</sup>**

- Compact DAW controller
- 100mm, touch-sensitive, motorized fader
- (3) touch touch-sensitive encoder
- (22) function buttons & 21 LED's
- 32-character back-lit display
- Power via USB connection
- Compatible with all major recording software
- Windows XP and Mac OS X compatible

**PRESONUS****Faderport**

The Presonus Faderport is a high-quality, USB motorized fader and transport controller, designed for use with all Mac & Windows-based recording software including: Pro Tools, Cubase, Nuendo, and Logic. This compact control surface features an ultra-smooth, long-throw fader, and dedicated pan, mute, solo, record enable buttons. The easy-to-use FaderPort simplifies writing automation & fades in real-time, and is equipped with a footswitch jack for hands free punch in/out recording.

#PRFPQ  
**\$149<sup>95</sup>**

- USB automation/transport controller
- Transport, pan, mute, solo, record enable controls
- Touch-sensitive, long-throw motorized fader
- Compatible with all major recording software
- Footswitch jack for punch in/out
- Includes: USB cable, power supply, and rubber feet

**ALESIS  
iO|Control**

The iO|Control is both a bus-powered Firewire audio interface and a software control surface, expressed in a sleek, compact frame. The unit includes dual microphone inputs and 1/4" outputs with 24-bit/96kHz resolution, along with eight ADAT Lightpipe channels.

The control surface features 4 rotary controls with 360° rotation, transport controls, and a robust jog/shuttle wheel. The unit is packaged with Cubase LE software.

#ALIOCONTROL  
**\$349<sup>00</sup>**

- (2) XLR mic inputs
- (2) 1/4" TSR line outputs
- 8-channel ADAT Lightpipe I/O
- 24-bit/96kHz recording resolution
- Jog/Shuttle, 4 rotary controls, 16 assignable buttons
- Back-lit LCD for immediate visual feedback
- 20 presets with full recall
- Mac and PC ASIO and Core Audio applications supported

**TASCAM  
FireOne**

The FireOne is a unique bus-powered desktop Firewire audio interface and control surface. The 2-in/2-out unit offers dual phantom-powered mic preamps and a Hi-Z instrument input.

The elegant control surface features logically arrayed control knobs, function switches, transport control keys, and a large back-lit jog wheel. The FireOne, which ships with audio software, is a self-contained solution for personal desktop music production.

#TAFO  
**\$249<sup>00</sup>**

- (2) XLR/1/4" Combo mic preamp inputs
- (1) 1/4" TS instrument input
- (2) 1/4" TRS line outputs
- (2) 1/4" TRS Headphone outputs
- 24-bit converters, SRC to 192kHz
- MIDI I/O
- Jog wheel, transport controls
- PC and Mac compatibility





## AKAI EWI4000S

The EWI4000S MIDI wind instrument has many of the long sought-after controls and functions that are necessary for expressive performance. This model features a lower price and several improvements to the design as well. It now features a built-in sound module, direct MIDI IN and Out, onboard effects and several other updated operating functions. With the sound module and the instrument all in one unit, players can move freely on the stage by using MIDI and audio wireless transceivers. With easily accessible controls for breath, vibrato, glide time, and bend width, users can adjust the settings of the EWI4000 to their specific playing style.

#AKEWI4000S  
**\$699<sup>00</sup>**



- User-customizable Electronic Wind Instrument
- Built-in analog modeling synth sound module
- MIDI in and out for controlling other sound modules
- Touch-sensitive keys with octave roller
- Sensitive breath sensor for expressive dynamics



## YAMAHA WX5

The Yamaha WX5 Wind MIDI Controller takes wind MIDI control to new levels of performance and playability. With precise, responsive wind and lip sensors, a choice of single-reed or recorder type mouthpieces, and a range of fingering modes, the WX5 makes expressive wind control more accessible than ever before. Connected to your favorite MIDI tone generator, it gives experienced wind players a new medium for expression in a familiar format and is even playable enough for beginners. This exciting instrument provides expressive control and nuances that are simply not available with keyboards or other MIDI controllers.

#YAWX5  
**\$599<sup>95</sup>**

- Wind MIDI controller with customizable features
- Connect to any MIDI tone generator or keyboard
- Single-reed or recorder type mouthpieces
- Wide range of fingering modes
- Pitch bend wheel and key hold button

### VL70-m

*physical modeling sound module with direct WX connection #YAVL70M.....* **\$599.95**

## YAMAHA BC3A

If your keyboard or sound module sports a "breath controller" input then you will definitely want to plug in a BC3A to see just what fun you have been missing. This unit is a lightweight headset that features a small mouthpiece which may be angled for your comfort and specific fit. Blowing with varied pressure transmits MIDI information to your tone generator to allow very expressive changes in volume, vibrato or any parameter that you select within your instrument. Keyboard and MIDI guitar players can now add nuances that were very difficult or impossible to achieve with other methods.

#YABC3A  
**\$89<sup>95</sup>**

- Headset style breath controller
- Connects to "breath control" input on many keyboards and sound modules
- Flexible mouthpiece for maximizing fit
- Sensitivity adjustment for tailoring "breath" amount
- Lightweight design for comfortable wear



## ROLAND PK-5A

The PK-5A Dynamic MIDI pedalboard lets you play a variety of sounds from any external MIDI device, leaving your hands free to play your favorite musical instrument. Easy one-foot operation gives you complete command over four separate performance modes, letting you play bass lines as well as harmonies, drums and percussion sounds, or even sound effects. Two-function footswitches provide instant control over a wide variety of useful parameters and you can also set the PK-5A's Performance Modes to transmit on any MIDI channel and switch to other channels simply by selecting the appropriate footswitch.

#ROPK5A  
**\$449<sup>50</sup>**



- Dynamic one-octave MIDI pedalboard
- 13 different levels of velocity sensitivity
- Transpose over a 9-octave range
- 4 separate performance modes: bass, poly, drums, SFX
- Adds new expressive potential to any musician's performance

## ROLAND PK-7A

The PK-7A is the ideal foot controller for the Roland VK series combo organs. This 20-key pedalboard allows for pedal bass control, complete with Pedal Attack and Pedal Sustain functions, adding even more authenticity to your organ performances. It features 2 footswitches for controlling Rotary slow/fast and Rotary Brake operation as well as VK parameter data like Seq Start/Stop, Preset Up/Down, Orch Glide, etc. This unit allows you to unleash the true depth of your VK and makes for a very portable yet powerful organ package.

#ROPK7A  
**\$1295<sup>00</sup>**



- 20-key MIDI pedalboard
- MIDI Merge function for enhanced MIDI control
- Built-in hold switch (damper)
- Separate expression, hold, foot-L, and foot-R outputs
- No power cable required when connected to VK-77 or 88

**HOSA**  
**FSC-384 / 385**

The FSC-384 is a single footswitch with one 1/4" TS (mono) jack ideal for changing amp channels. FSC-385 Dual-footswitch version  
**FSC-385** 2-space black anodized version  
#HOFSDL ..... **\$24.95**

#HOFSSL  
**\$19.95**



**HOSA**  
**FSC-501**

The FSC-501 is a latching switch (push-on/push again for off) ideal for guitar amp channel switching, on/off effects units.

#HOFSP1  
**\$19.95**



**HOSA**  
**FSC-502**

The FSC-502 is a momentary switch (normally open). Ideal for use as sustain pedal, patch-advance switch/punch-in/out switch for multi-track recorders.

#HOFMNO  
**\$19.95**



**FSC-503** momentary switch (normally closed) #HOFMNC..... **\$19.95**

**HOSA**  
**FSC-604**

The FSC-604 is a selectable momentary switch (open/closed) ideal for use as a sustain pedal, patch-advance switch, or punch-in/out switch for multi-track recorders.

#HOFMNC  
**\$26.50**



**ROLAND**  
**FS-1**

The FS-1 Foot Switch provides simple control of on/off functions like channel/effects switching on guitar amps.

#ROFS1  
**\$23.95**



**ROLAND**  
**RP8**

The FS-1 Foot Switch provides simple control of on/off functions like channel/effects switching on guitar amps.

#RORP8  
**\$34.95**



**ROLAND**  
**FS-5L / 5U**

The FS-5L is a sturdy metal, latch-type momentary footswitch with an LED to indicate the pedals status.

#ROFS5L  
**\$29.95**



**FS-5U** Unlatch-type momentary footswitch  
#ROFS5U..... **\$29.95**

**YAMAHA**  
**FC 5**

The FSC-501 is a latching switch (push-on/push again for off) ideal for guitar amp channel switching, on/off effects units.

#YAFCS  
**\$19.95**



**BOSS**  
**FS6**

The FS-6 is a flexible dual footswitch that allows each switch to be set for either latch or momentary operation.

#BOFS6  
**\$46.50**



**M-AUDIO**  
**SP-1**

The SP-1 is a non-latching momentary switch for use as a sustain foot pedal or FS controller for synthesizers and drum machines.

#MASP1  
**\$19.95**



**YAMAHA**  
**FC 3**

The FC3 is a dual-zone piano style sustain pedal with a unique continuous zone that allows for different types of sustain. (6-ft. cable w/ 1/4" jack)

#YAFCS  
**\$48.50**



**YAMAHA**  
**FC 4**

The FC4 is a piano-style sustain pedal that can also be utilized as an FS controller for synthesizers and drum machines. (6-ft. cable w/ 1/4" jack)

#YAFCS  
**\$29.95**



**M-AUDIO**  
**SP-2**

The SP-2 is a heavy duty piano-style sustain pedal with a rubber-coated shell and chrome foot pedal. (6-ft. cable with 1/4" jack)

#MASP2  
**\$29.95**



**YAMAHA**  
**FC 7**

The FC7 is a durable volume controller that allows you to adjust the volume or the effects of your instrument. (6-ft. cable with 1/4" jack)

#YAFCS  
**\$39.95**



**M-AUDIO**  
**EX-P**

The EX-P is a universal expression control pedal with a built-in polarity switch that ensures compatibility with most brands of controllers and keyboards (molded construction with integral cable).

#MAEXP  
**\$29.95**



**ROLAND**  
**EV-5**

The EV-5 is an ultra-compact expression pedal that can control a wide range of functions and effects parameters in real time.

#ROEV5  
**\$74.95**



## ALESIS Performance Pad

#ALPP  
**\$299<sup>00</sup>**



The Performance Pad is a self-contained percussion performance station and controller, equipped with 8 velocity-sensitive pads and a built-in drum machine with 50 presets and 50 drum kits. The unit includes inputs for bass drum and hi-hat pedals, and a line-level in for connections to audio playback devices. The unit is capable of 16-voice polyphony, and 12 simultaneous sounds are accessible from the pads.

- Dynamic Articulation for pads adds nuance, expressiveness
- 16- and 24-bit sample/DAC resolution
- 24-bit stereo and headphone outputs
- Built-in drum machine with 12,000-note sequencer
- MIDI output for external triggering
- Mounting holes for easy drum kit attachment
- Large LCD screen

## ALESIS SR16

#ALSR16  
**\$149<sup>00</sup>**



The Alesis SR-16 is a classic 16-bit stereo drum machine designed for composition, recording, and accompaniment applications. It features 233 realistic, natural drum sounds (supplied both dry and sampled with digital reverb). This compact drum machine provides complete MIDI implementation, a footswitch input, flexible programming and editing features and 12 velocity-sensitive pad buttons.

It features 233 realistic, natural drum sounds (supplied both dry and sampled with digital reverb). This compact drum machine provides complete MIDI implementation, a footswitch input, flexible programming and editing features and 12 velocity-sensitive pad buttons.

- 233 realistic, natural drum sounds
- 12 velocity-sensitive pads with Dynamic Articulation
- 50 preset & 50 user Kits
- 200 user & 200 preset patterns
- 16-voice polyphony
- (4) 1/4" outputs (2 stereo pairs)
- 2 footswitch jacks

## ROLAND SPD-20

#ROSPD20  
**\$699<sup>95</sup>**



The SPD-20 Total Percussion Pad is an electronic percussion multi-pad with 700 high-quality percussion, drum, and instrument sounds built-in. It is equipped with 8 velocity-sensitive rubber pads, four dual-trigger inputs for triggering SPD-20 sounds from external pads and other triggering devices and onboard multi effects including reverb, delay, chorus and flanger.

- 700 high-quality drum and percussion sounds
- 8 velocity-sensitive rubber pads
- Internal memory: 99 patches, 8 patch chain
- 14 voice polyphony
- Sound parameters: instrument, level, pitch, decay, pan, curve, effect send level
- (4) dual-trigger inputs for external triggers
- Built-in multi-effects

## ROLAND HPD-15

#ROHPD15  
**\$895<sup>00</sup>**



The HPD-15 HandSonic is an electronic hand percussion multi-pad with 600 realistic acoustic and electronic percussion sounds and versatile real-time control. It features a 10" rubber pad with 15 parts, a built-in sequencer and onboard effects include reverb and multi-effects processors. It uses triggering capabilities technology from Roland's V-Drums, and a built-in pressure sensor allows for realistic muting and pitch control of sounds.

- Electronic hand percussion pad w/ V-Drums technology
- 300 percussion and drum sounds from around the world
- D-Beam controller, dual ribbon controllers, three control knobs
- 10" rubber pad with 15 parts for triggering
- Built-in multi-effects processors
- Dual-trigger input and hi-hat control jack

## ALESIS SR-18

#ALSR18  
**\$249<sup>00</sup>**



Alesis has quite a successful history with great sounding and affordable drum machines. The SR-18 continues the legacy with new sounds, a new design, and the ability to run on either AC or battery power for true portability. Along with the ability to write your own custom patterns, this machine comes stock with beats to cover all the bases from hip-hop to country and everything in-between. The effects engine includes reverb, EQ and compression to get just the sound you are looking for.

- 32MB sound set includes percussion and bass synth sounds
- Trigger entire patterns from pads for easy composition
- Mute/solo function for drum, bass, and percussion parts
- 32 voice polyphony with backlit LCD
- Battery powerable for work on the go



## BOSS DR-880

The Dr. Rhythm DR-880 is a powerful drum machine with innovative features including: a Hi-Z instrument input for guitar & bass, a coaxial S/PDIF output, 3 independent insert effects and proprietary COSM amp modeling. It provides 440 world-class drum and percussion sounds, 40 bass sounds (with COSM bass-amp models) and a unique "EZ Compose" feature for quick, hassle-free programming.

- 20 velocity-sensitive pads • Guitar/bass input, multi-effects, COSM amp models
- TSC with Sound Shape function and Ambience • 1,000 patterns (500 preset, 500 user)
- Coaxial S/PDIF digital output • Stereo RCA & (2) 1/4" outputs
- (4) Footswitch and expression-pedal inputs



#RODR880  
**\$495<sup>00</sup>**

## BOSS DR-670



The Dr. Rhythm DR-670 is a feature-packed drum machine with a unique pad interface designed like a bass guitar neck for easy programming of rhythm/bass lines. Its unique "Direct Pattern Play" function allows users to assign internal patterns to 16 pads for triggering in real-time, and preset and user patterns can be easily chained together to create up to 100 songs.

- 255 drum and percussion waveforms • 16 velocity-sensitive pads
- 200 Preset or User patterns • Stereo 1/4" & 1/8" stereo headphone outputs
- Unique Direct Pattern Play function • Pedal Switch input
- Powers via: AC or battery power

#RODR670  
**\$279<sup>00</sup>**

## BOSS DR3

The Dr. Rhythm DR3 is an affordable drum machine designed for guitarists and songwriters. Great for jamming or practice, the DR3 provides 13 velocity-sensitive pads, BOSS' best acoustic and electronic drum kits and a great selection of bass sounds. It can power via batteries, and an optional footswitch can be used to control many of the useful functions.

- 100 Preset Styles and 100 User styles
- Realistic drum, percussion, and bass sounds
- Rhythm Progressions with 3 variations of Intro, Verse, Fill, and Ending
- TSC with Sound Shape function and Ambience • Stereo RCA & (2) 1/4" outputs
- Footswitch input for easy live control • Powers via: AC or battery power



#RODR3  
**\$179<sup>00</sup>**

## ZOOM RT-223

The Zoom RT-223 is a battery operated drum machine with 511 rhythm patterns, 70 preset drum kits, 127 user-programmed kits, 39 sounds and 12 bass sound sources. Its FAST (Formula Assisted Song Translator) song creation function simplifies song arrangement, and speeds up the process of assembling songs with repeated patterns and sequences.



#ZORT223  
**\$179<sup>00</sup>**

- Lightweight portable drum machine
- 511 Rhythm Patterns : (440-factory, 71-blank)
- Touch-sensitive drum pads, Groove Play pad assignment
- FAST(Formula Assisted Song Translator) song creation function • Built-in multi-band compressor/EQ & multi-effects • Line input for external audio
- Powers via: (4) AA batteries or optional AD-0006 AC adapter

## ZOOM SB-246



#ZOSB246  
**\$178<sup>95</sup>**

The Zoom Streetbox SB-246 is a rhythm machine designed for creating all styles of Hip Hop. It features 529 authentic Hip

Hop sounds and an easy-to-use loop pattern sequencer for putting together complex tracks. Equally at home on stage and in the studio, the SB-246 can operate continuously for 8 hours on four AA batteries, making it ideal for portable applications.

- 529 authentic Hip Hop sounds
- 210 preset patterns produced by Beat Kangz
- 24 bass sound sources
- Loop pattern sequencer optimized for Hip Hop
- Built-in multi-band compressor/EQ & multi-effects
- Stereo (L,R) 1/4" outputs
- Powers via: (4) AA batteries or optional AD-0006 AC adapter

## BOSS SP-404

The SP-404 is an easy-to-use portable sampler capable of recording and looping samples in real-time. Samples can then easily be assigned to any of the large twelve trigger pads, processed using 29 different effects, edited with powerful sample-editing tools and then stored as .WAV or .AIFF files on up to 1GB Compact Flash media cards. A built-in microphone makes for quick setup and recording with no cables to connect.



#ROSP404  
**\$395<sup>00</sup>**

- 12-voice sampler with 12 pads and built-in microphone
- Create up to 24 patterns with up to 8000 notes
- 29 expressive effects controlled in real-time via 3 front-panel knobs
- Import or export .WAV or .AIFF via up to 1GB CompactFlash
- RCA line I/O, MIDI in • Battery or AC powered

## ROLAND SP-606



#ROSP606  
**\$695<sup>00</sup>**

The 8-voice SP-606 is a table-top sampler/sequencer capable of importing or sampling direct from its stereo analog/digital inputs or audio supported USB port. Audio can be synchronized, edited and sequenced using BPM sync control, powerful sample sculpting tools, and an internal 4-track, 18,000 note sequencer. Capable of truncating recorded audio automatically, the SP-606 is ideal for quickly building sample libraries

- 8-voice polyphonic with 4-track 18,000 note sequencer
- Velocity-sensitive pad bank, expressive D-Beam, and three assignable knobs
- 45 effect algorithms including Mastering Effects
- Compact Flash storage (512MB max.) .WAV/AIFF formats
- Computer control integration with P606 Virtual Groove Box software

## AKAI MPC1000

The MPC1000 combines great feeling, velocity/pressure sensitive pads into a 64-track MIDI sequencer with 32-voice Stereo Digital Sampler. Although it inherits the same legendary "feel" and "groove" of older MPC's, it adds welcome new features, including: two Q-link sliders, two separate multi-effects processors, resonant multi-mode filters, 4-way sample layering and velocity switching per pad, and standard multiple audio outputs.



#AKMPC1000BK  
**\$999<sup>00</sup>**

- Pattern-based 64-track sequencer with 32 MIDI channels
- 32-voice drum/phrase sampler with up to 128MB ram
- Transfer/store via Compact Flash (2GB) max. or USB port
- Master and dual multi-effects engines
- 1/4" balanced inputs, 1/4" unbalanced outputs, digital I/O S/PDIF (coaxial)

## AKAI MPC2500



The MPC2500 is a professional sampling music production center that combines a 64-track MIDI sequencer with a 32-voice, 16-bit stereo digital sampler. It features 16 velocity and pressure sensitive pads for more natural and efficient drum programming, two internal effects processors, extensive connectivity and a host of new features including Chop Shop- the ability to slice loops, automatically assign them to a pad, and synchronize the resulting loops/phrases to any tempo without changing pitch.

#AKMPC2500  
**\$1699<sup>00</sup>**

- 64-track, 32-voice music production sequencer
- Extensive sample editing including resampling, slice, pitch-shift and more
- Classic MPC "feel" and "sound" with 16 velocity and pressure sensitive pads
- New features include: Patched Phrase, Grid Edit, Effect and LFO sync
- 10 built-in outputs, 2 MIDI inputs/4 MIDI outputs, USB port for Mac/PC connection
- MPC and .WAV file compatible

## AKAI MPC500

The MPC500 is a full music production device that offers true portability with battery-powered operation. It features a pattern-based 48-Track MIDI sequencer, a 32-voice stereo digital sampler, and 4 banks of 12 velocity and pressure sensitive pads. A USB port provides an easy way to load data to and from the MPC500's CompactFlash card. You can do crafty things like layer 4 samples per pad addressing them through velocity sensitivity.



#AKMPC500  
**\$2799<sup>00</sup>**

- (12) velocity and pressure sensitive pads, (4) pad banks
- (2) 1/4" inputs and (2) 1/4" outputs, MIDI I/O
- 16 MB installed memory, expandable to 128 MB
- Compatible with the full MPC line
- Low-pass filter and on-board stereo effects
- Internal sounds included to get started • 2.9 lbs, 10.47 (W) x 1.73 (H) x 6.89" (D)

## KORG KAOSSILATOR

#KOKO1  
**\$199<sup>00</sup>**

The Korg KAOSILATOR is a pocket-sized synthesizer and phrase generator equipped with a dynamic touchpad controller. The device is loaded with 100 programs combining a variety of sounds culled from Korg's modeling synth lineage, with note/pitch control and cutoff, feedback or mod control from the touchpad's horizontal and vertical axis. The KAOSILATOR is an innovative and inexpensive alternative to keyboard performance for musicians and DJ's



- Ultra-compact portable synthesizer and phrase generator
- Touchpad parameter and expression controller
- 100 synth and instrument models range from drums loops to synth pads
- (3) multi-function controller buttons, rotary control wheel
- Scale function with 31 scales to match any musical setting
- Loop Recording and internal Gate Arpeggiator

## ROLAND MC-808

#ROMC808  
**\$799<sup>00</sup>**



The MC-808 combines a powerful 128-voice synthesizer, sampler, and sequencer into a single box with 8 motorized faders—ideal for live performance recall. Build and manipulate tracks from scratch by incorporating hundreds of internal patterns, arpeggiations, and effects with externally-sampled or imported audio. Up to 512MB of samples can be accessed internally, transferred to computer through USB and imported/exported in .WAV and .AIFF formats.

- 128-voice synth, sampler, and sequencer workstation
- Create 16-part sequences from over 1000 user patches and 128 drum kits
- Sample or import external audio to be edited, processed, and mixed
- Multi-effects processing including mastering and pitch shifter
- 1GB CompactFlash backup
- 1/4" I/O, USB connection with editor software



## KORG Electribe ESX-1

#KOESX1  
**\$499<sup>00</sup>**

The ESX-1 Rhythm/Sampler combines a sample-based sound set with the ability to record your own samples. Samples can be sliced and divided at their rhythmic peaks allowing individual muting, pitch, filter, or effecting, while phrase loops can be assigned to Stretch Parts, freely adjusting tempo without affecting pitch. While

recording in Realtime or Step mode, a powerful arpeggiator, ribbon controller and slider are available for further expressive control.

- 16 total instrument parts
- 384 max. internal samples/285 (mono) seconds 128 (stereo) max.
- All knob movements recorded by Motion Sequencing
- Dual-tube output for increased warmth and presence
- 256 patterns/64 songs
- Import/store samples via Smart Media card (128MB max)

## KORG Electribe EMX-1

#KOEMX1  
**\$499<sup>00</sup>**

The EMX-1 is a creatively expressive dance and hip-hop production sequencer that combines powerful synthesis models, sample-based drums, and unique organic sounds into a stylish and durable chassis. Produce crisp leads, textured beds, morphing waveforms, and more with 9 drum, 5 synth, and an accent part for added dynamics. Ideal for DJ's and producers, the EMX-1 can produce a vast amount of sound from such a small package.



- Multiple modeling synthesis styles (16 algorithms total)
- Over 200 percussion and 70 synth samples internal
- Intuitive realtime/step-time recording with Motion Sequencing and expanded pattern lengths
- Audio input allows outside source to run through filters and effects

## ROLAND MV-8800

#ROMV8800  
**\$2295<sup>00</sup>**



The MV-8800 is a complete desktop audio production solution. The unit consists of a programmable 64-voice polyphonic drum machine with 16 velocity-sensitive pads and an extensive drum kit library,

an automated 24-track hard disk recording and mixing section with extensive effects processing and mastering tools, and a built-in CD burner. The unit supports WAV and AIFF recording file formats, and reads sample files from Roland and Akai.

- Integrated desktop audio production workstation
- 24-track hard disk recording, mixing, and mastering
- Drum machine with 16 velocity-sensitive pads
- Internal 40GB hard drive and CD burner
- Large back-lit LCD
- Versatile effects and drum set sound library
- USB, MIDI, coax and optical SPDIF, 1/4" analog connectivity





## YAMAHA MM6

#YAMM6  
**\$599<sup>99</sup>**

The MM6 is a 61-key programmable keyboard synthesizer with 32-voice polyphony and a host of control knobs and switches, expressed in a high-tech, lightweight form. The 418 high-quality voices and 22 drum kits are culled from the renowned MOTIF series sound library, and an arpeggiator, along with a collection of multi-genre play-along preset rhythm patterns, is also available.

- Professional sounds from MOTIF library
- Real-time pitch and mod wheel controls
- Built-in arpeggiator and 8-track sequencer
- 249 internal effects with reverb, chorus, master EQ, and variations
- Performance memory for all edits, settings
- Full connectivity includes MIDI and USB, headphone out
- Dual pedal inputs, stereo audio output
- Compact and lightweight for easy transportation



## YAMAHA MOTIF XS6

#YAMXS6  
**\$2199<sup>99</sup>**

The MOTIF XS6 is a professional 61-key workstation keyboard with 128-voice polyphony. The unit is equipped with a huge library of sounds, a large back-lit LCD, and an expanded controller section featuring a ribbon controller. The 16-track sequencer allows for audio recording and playback in .WAV and .AIFF file formats, while providing seamless co-integration with DAW software such as Digital Performer, Logic, Sonar, and many others.

- 61-note keyboard with Initial Touch and Aftertouch
- 1024-voice sound library, 64 drum kits
- Arpeggiator with 6,000-phrase programmable collection
- 16-track, 130,000-note sequencer with .WAV/.AIFF audio
- 8 assignable knobs, 8 assignable sliders
- Ribbon controller, pitch and mod wheels
- (2) DIMMS Sample RAM slots
- Analog 1/4", MIDI, Ethernet, SPDIF and USB connectors



## KORG TR-61

#KOTR61  
**\$999<sup>00</sup>**

The Korg TR is a 61-key synthesizer workstation with up to 512 programs, 384 combinations, and 24 drum kits comprising its comprehensive 64Mb sound set. Although double the size, it's based on the classic Triton sound engine. Several new sample waveforms are taken from the flagship Oasys synth while still maintaining the same expressive rhythmic patterns, arpeggiators and sophisticated multi-effects capabilities of the original Triton. Reliable USB MIDI capabilities and SD storage up to 1GB are built-in.

- 61-key synth workstation based on classic Triton engine
- 16-track sequencer with up to 200-song, 200,000-note capacity
- Record immediately using song recording templates and Auto Song Setup function
- Dual polyphonic arpeggiators with over 200 built-in patterns
- Quick "category select" of Programs and Combinations
- Sampling option available



## ROLAND Fantom X-6

#ROFX6  
**\$1895<sup>00</sup>**

The Fantom X6 is a 61-note, 128-voice version of the flagship Fantom series keyboards. Now with 8-tracks of audio recording capability, Roland has provided greater creative options by integrating almost 1GB of expanded internal and external wave memory seamlessly into a powerful sequencing, sampling instrument. Real-time audio editing, extensive effects processing, and convenient .WAV/.AIFF file exchange make the sonically inspiring Fantom X6 an ideal production tool for studio or live performance R&B, Rap, Electronic, or contemporary Pop music.

- 61-note/128-voice polyphony/Up to 1GB internal wave memory
- Skip Back Sampling automatically records phrases and recalls them instantly
- 4 x SRX, 544MB RAM, and 1GB PC Card slot (Smart Media/CompactFlash) expansion
- Color LCD screen
- Record directly to RAM automatically syncing Audio/MIDI

**Fantom X-R** 128-voice polyphony Synth Rack/over 1GB sound expansion/USB & PC Card storage #ROFXR .....**\$1395.00**

**OPEN LABS****Timbaland Miko**#OPMTIM4  
**\$4299<sup>00</sup>**

The Timbaland Special Edition Miko keyboard workcenter takes the features of the Miko LX to new levels. The all-new arctic white chassis is a truly unique touch and the standard 4GB of RAM gives you enough power to sink your teeth into the most memory-intensive software instruments. Emu's Proteus X2 Streaming Sound Module provides a powerful platform to support hundreds of sounds specifically requested by Timbaland, including the Ensoniq Urban Legends library along with the already huge Open Labs soundest V4. This unit contains many of Timbaland's favorite sounds which are only available on this powerful machine.

- Full portable production workstation with Timbaland spec
- Thousands of unique Ensoniq ASR and EPS sounds
- Core2Quad Quad-core 64-bit (2.4GHz) CPU
- High quality Alpha Control and DJ modules
- Low latency recording with 24-bit/96kHz capability

**OPEN LABS****NeKo Timbaland Special Edition**#OPNTSE  
**\$4999<sup>00</sup>**

The NeKo Timbaland Special Edition is a road-worthy, Windows XP-powered 61-key workstation keyboard, designed in cooperation with master music producer Timbaland, to be a portable production studio. The unit comes with a 2.4GHz CPU, an enormous collection of Audio/MIDI recording and virtual instrument software, a Presonus Firebox audio interface, a 15" Touch Screen LCD display, a Qwerty keyboard, 4GB of RAM, and a Terrabyte of internal storage.

- Open-ended 61-key workstation keyboard and control surface
- Semi-weighted keys, CPU-dependent polyphony
- Dedicated DJ controller module with cross-fader, (7) knobs, (12) buttons
- Dedicated Alpha Control Module with 23 sliders and buttons
- High-speed, dual-layer CD/DVD burner
- Over 35GB of sounds from over 60 virtual instruments
- 24-bit/96kHz recording resolution, mic inputs with phantom power
- USB, Firewire and Ethernet ports

**KURZWEIL****K2661**#KUK2661  
**\$2995<sup>00</sup>**

With a 61-note synth-action, uncompromised audio quality, and extensive sound creation capabilities, the K2661 is designed for the professional studio and performing musician. Its sound set includes over 600 of Kurzweil's best programs and setups, KB-3 mode, and Triple mode, all processed through the creatively inspiring KDFX multi-effects processor. Although extremely flexible for sound creation, the K2661 is also an incredibly powerful MIDI controller, capable of controlling multiple sources simultaneously for maximum flexibility in any style of music.

- 500 programs/100 setups easily expandable
- KB3 mode Tone Wheel Organ modeling uses 8 sliders and wheel as drawbars
- Triple Mode combines 127 different algorithms to create stunning, more "analog" sounds
- Simultaneous sample and sequence capability (RAM tracks)
- 8-channel ADAT I/O or stereo S/PDIF
- Sample storage via SCSI or 128MB SmartMedia

**KURZWEIL****K2600XS**#KUK2600XS  
**\$5190<sup>00</sup>**

The flagship K2600XS represents the culmination of Kurzweil's many years of experience on stages and in countless studios around the world. Top touring acts and programmers praise its superior sound quality while musicians look to it as the ultimate all-in-one compositional tool. This workstation features an excellent performance control set, stunning KDFX 24-bit studio-grade processing and the included KB-3 Tone Wheel Organ modeling mode. In addition to its own sampling capabilities, the K2600SX will load sound data in most other major formats making its sound library immense.

- 88-note fully weighted sampling synthesizer workstation
- (8) sliders, (2) ribbon controllers, (6) pedal inputs and breath controller input
- Extensive sample-processing and importing capabilities
- Live Mode for real-time external audio processing
- (8) balanced 1/4" outputs, AES and S/PDIF I/O

**RM326 Triple-Strike Piano ROM #KURM326.....\$239.95**



**ALESIS**  
**Fusion 8HD**

#ALF8HD  
**\$1499<sup>00</sup>**

The Fusion 8HD is a unique 88-key synthesizer workstation featuring four different synthesis types including: Sampling/Sample Playback, Virtual Analog, FM Synthesis, and Physical Modeling. Combining this synthesis power along with professional 24-bit I/O, a 32-track MIDI sequencer with true 8-track hard-disk recording, and up to 192MB of internal RAM for custom or imported samples, you begin to understand how the Fusion allows musicians an almost limitless palette of tools for creating professional live or studio projects.

- 88-key fully-weighted sampling workstation with 8-track, 24-bit audio recording
- Synthesis types: Sample based, Virtual Analog, FM and Physical Modeling
- More than 800 preset programs with 200 mixes
- 32-track sequencer with arpeggiator with 1,000 preset patterns
- Import samples via USB or Compact Flash to internal 40GB hard drive
- New hall of sound banks
- 56 lbs

**Fusion 6HD** 61-key version #ALF6HD .....**\$999.00**



**KORG**  
**M3-61**

#KOM361  
**\$2499<sup>00</sup>**

The M3-61 is a 61-key sampling workstation keyboard with 120-voice polyphony, a large color touchview screen that doubles as an X/Y control pad, a huge multi-sample sound library, and an extensive DAW co-integration functionality. The proprietary EDS sound-generating system is derived from Korg's renowned OASYS and KARMA synth engines, and the unit may be used as a virtual VST, RTAS or Audio Unit plug-in.

- 61-key sampling workstation keyboard and programmable synth
- Huge 1,600+ drum sample library, 1,028 multi-samples
- 170 dynamics, multi-effects, amp and speaker simulators
- Touchview LCD, (8) drum pads, (8) assignable slider controls
- Open Sampling System with cross-fade looping, time stretch
- 16-track, 210,000-note sequencer
- MIDI, TOSLINK optical SPDIF, 1/4" TS phone connectivity

**M3-73** 73-key version of above #KOM373..... **\$2899.00**

**M3-88** 88-key version of above #KOM388..... **\$3499.00**



**ROLAND**  
**Juno-G**

#ROJG  
**\$995<sup>00</sup>**

The Juno-G is an affordable, user-friendly workstation that packs a studio's worth of sound, sequencing, and audio recording into one amazing instrument. At its core is the same high-powered processor found in the Fantom-X series, providing a library of rich and diverse patches with first-class performance features. Add to this an audio/MIDI recorder with dedicated transport controls and mixer plus USB connectivity for easy WAV/AIFF file and patch data transfer.

- 61-note workstation with 128-voice polyphony
- 16-part MIDI sequencer with 4 stereo audio tracks
- Powerful "Fantom-X-quality" sound engine
- Large friendly display and front panel controls
- Arpeggiator, Chord Memory and multi-effects built in
- USB port for MIDI communication & data transfer
- Infrared D Beam controller
- PC card slot
- Includes free Calewalk Sonar LE software



**ROLAND**  
**VP-550**

#ROVP550  
**\$1295<sup>00</sup>**

For musicians who can't accommodate a choir or group of background singers for their gigs or recording sessions, Roland proudly presents the VP-550 Vocal Designer Keyboard. Much more than a traditional vocoder or harmonizer, it uses breakthrough vocal-modeling technology to bring the highest-quality, interactive vocal sounds to a dedicated instrument. Spectacular classical choirs, soulful gospel choirs, pop and jazz voices, male & female ensembles, vintage vocoding, and lush string/vocal hybrids are all quickly addressable with its streamlined interface.

- 49-key interactive real time backing vocal generator
- Perfect for solo performers and houses of worship
- No hidden menus and lots of dedicated controls
- Also equipped with high-resolution vocoder modeling





## YAMAHA S08

#YAS08  
**\$999<sup>00</sup>**

The S08 gives you professional quality sound and a full-size weighted keyboard in a lightweight package. The vast sound set is easily managed with the Category Search feature and built-in USB interface makes computer connection fast and easy. Its keyboard has been specially designed to accommodate both the need for weighted feel and quick response across the entire length of the keyboard, allowing you to enjoy smooth, weighted action regardless of which voice you play.

- 88-note weighted action synthesizer
- Balanced hammer-effect keyboard mechanism
- Large sound library with "Category Search"
- 64 voice polyphony
- Built-in USB MIDI interface
- Onboard 24-bit multi-effect processors
- 16-part, multi-timbral SMF playback sequencer
- SmartMedia card slot
- Sequencing and voice editing software included



## YAMAHA S90 ES

#YAS90ES  
**\$2099<sup>00</sup>**

The S90 ES combines a stunningly natural acoustic piano sound with all the sonic flexibility of the award winning Motif ES. A new multi-velocity, stereo grand piano sample, the new sound board simulation and the half-damper capability (when used with the Yamaha FC3) all ensure a rich and realistic acoustic piano sound. Add to this the ability to install up to three PLG expansion boards and you have the makings of a very powerful and versatile machine. The S90 gives you the solid feel and response of a professional digital piano along with the ability to handle just about any gig that might come your way.

- 88-key weighted action synthesizer with aftertouch
- 53 MB of memory is dedicated to the new grand piano voice
- 228MB of wave memory holds an enormous sound library
- Accepts up to three optional PLG expansion boards
- Studio Connections software allows the S90 to act as a plug-in
- Powerful arpeggiator draws on a library of 1787 phrases



## KURZWEIL PC3X

#KUPC3X  
**\$2730<sup>00</sup>**

The PC3X is an 88-note performance controller keyboard/workstation with 128-voice polyphony. The unit deploys Kurzweil's proprietary Dynamic V.A.S.T. synth architecture and includes the renowned Triple-Strike Grand Piano and VA-1 virtual analog synthesizer. Other goodies include a high-res sequencer with an unlimited track count, a sound library with over 800 programs, a huge backlit display, and the KB3 tonewheel organ simulator with 9 sliders for real-time drawbar control.

- 88-note performance/controller keyboard with weighted hammer-action keys
- Full velocity-sensitivity and Aftertouch, 128-voice polyphony
- 850+ presets, KB3, VA-1 and Triple Strike Grand built-in
- Sequencer with unlimited track count and 1536 PPQ resolution
- (16) independent programmable arpeggiators
- (9) assignable sliders with Drawbar mode for KB3 organ sounds
- (96) Factory and (128) User MIDI presets with 16 zones
- Ribbon, Breath and (5) Switch and Continuous Control pedal ins



## KURZWEIL PC1SE

#KUPC1SE  
**\$1829<sup>00</sup>**

Musicians have been asking for a fully-weighted 76-note performance keyboard for years and with the new PC1SE players can now gain all the advantages of piano style action in a much easier-to-transport package. Kurzweil has wrapped their famed Triple-Strike Piano, a host of other breathtaking sounds and impressive controller capabilities into a professional package that will make a noticeable difference in tight stage setups. Its road proven design, unique Classic Keys ROM and pressure sensitive keyboard make it the perfect centerpiece of your rig.

- 76-note, fully-weighted performance controller
- Both Orchestral and Classic Keys ROM expansions included
- Award winning effects section bring sounds to life
- 128 user setups each with 4 independent zones
- Full featured arpeggiator and numerous front panel controllers
- High-resolution effects processor delivers full and rich sound
- Flash ROM upgradeable



## KORG X-50

#KOX50  
**\$699<sup>00</sup>**

Featuring a compact, light-weight design, the 61-key X-50 performance synthesizer is loaded with 512 programs and 384 combinations derived from the world-renowned Triton synth engine. It utilizes a powerful effects section, dual polyphonic arpeggiators with 256 patterns, and individual outputs for further external mixing. Sounds are auditioned with one button press and are organized conveniently into 16 categories for quick and easy selection.

- 61-note performance synthesizer with 62-voice polyphony
- 512 programs and 384 combinations
- Convenient, lightweight design for studio or live performance
- 4-channel audio outputs, 4 effect processors, dual polyphonic arps
- USB MIDI connection with stand-alone or innovative plug-in sound editor
- Multi-mode allows external control
- Compact size fits in even the tightest workspace



## KORG microX

#KOMICROX  
**\$649<sup>00</sup>**

The microX is a compact 25-key synthesizer designed to integrate easily into today's computer-based music systems. Its advanced control functions provide 64 external control templates for popular software synths and DAW programs along with the expressive manipulation of more than 1,000 internal programs and combinations that cover the most popular musical genres and production styles. Dual polyphonic arpeggiators with 251 phrases and up to four high-quality effects at once adds to the microX's creative potential.

- 25-key synthesizer with 62-voice polyphony
- 64Mb ROM with 640 programs and 384 combinations
- 64 built-in control templates for software and DAW control
- 4 individual outputs and USB connection (MIDI only)
- Synth engine based on famous Triton series
- Up to four stereo effects at once



## ROLAND Juno-D

#ROJD  
**\$495<sup>00</sup>**

Ideal for both veteran and beginning synthesists, the intuitive Juno-D is an inexpensive 61-note, 64-voice polyphonic synthesizer designed to provide users with one of the most expressive, full-featured keyboards in its class. Direct access buttons easily select between 640 patches, 20 rhythm sets and the powerful arpeggiator's 400 phrase templates, all which are easily manipulated and processed via 5 front-panel controls and 47 different multi-effects.

- 61-note synth with aftertouch, 64-voice polyphony and flexible real-time control
- 640 expressive patches with 20 rhythm sets
- Patches are organized in categories and are selected via Direct Access buttons
- Multi-chord memory for one-finger chord triggering
- 47 multi-effects, 8 reverb types and 8 chorus types
- USB interface and Mac/PC editing software included
- Built-in "D-Beam" controller



## ROLAND GW-7

#ROGW7  
**\$695<sup>00</sup>**

The Roland GW-7 is an inexpensive Arranger keyboard equipped with 61 velocity-sensitive keys, and an unusually large and bright backlit display. This model is notable for a large selection of usable, high quality custom and GM2 sounds, and an elegant, simplified operation with dedicated, clearly labeled function buttons and controllers. The unit is a worthy choice for beginning students and songwriters, or seasoned music hobbyists.

- 61-key Arranger keyboard with 64-voice polyphony
- Built-in 16-track sequencer with 99-song memory
- Built-in reverb, chorus and multi-effects sound processors
- USB port, Windows and Mac compatibility
- Large on-board collection of editable Style Patterns
- Custom collection of sampled world instruments

**KORG****X50 Limited Edition Camouflage**#KOX50CF  
**\$749<sup>00</sup>**

Featuring a compact, light-weight design with a hot-looking limited-edition camouflage finish, the 61-key X-50 performance synthesizer is loaded with sounds derived from the world-renowned Triton synth engine. It utilizes a powerful effects section, dual polyphonic arpeggiators with 256 patterns, and individual outputs for further external mixing. Sounds are auditioned with one button press and are organized conveniently into 16 categories for quick and easy selection.

- 61-note performance synthesizer with 62-voice polyphony
- 512 programs and 384 combinations
- Convenient lightweight design for studio or live performance
- 4-channel audio outputs, 4 effect processors
- USB/MIDI connection with stand-alone or plug-in sound editing
- Multi-mode allows external control

**YAMAHA****MO6**#YAM06  
**\$1199<sup>00</sup>**

The MO6 carries the same massive 175MB wave ROM and synth engine found in the flagship MOTIF ES series, leaving no doubt as to its readiness to handle any type of music production situation. Whether you are gigging, songwriting, doing studio sessions, or integrating into a computer music environment, the MO6 can adapt to each of these applications and their special demands and provide just the right feature set for each situation. And, like the Motif, it includes a well laid out Song and Pattern for getting your ideas down fast.

- 61-note production workstation
- Phrase Factory produces complete grooves for song inspiration
- Real-time control knobs and sliders for instant tweaking
- Remote mode for control of DAW's and SoftSynth's

**Yamaha MO8** 88-note weighted hammer action version of above  
#YAM08.....**\$1598.95**

**KORG****RADIUS-R**#KORADIASR  
**\$999<sup>00</sup>**

The Radius-R is a rackmount programmable modeling synthesizer and 16-band vocoder module designed using Korg's proprietary MMT modeling technology. The unit offers a variety of synthesis algorithms together with multiple effects, advanced comb filter and wave shaping features, modulation sequencing, and formant-motion vocoding. This is an innovative instrument offering classic, current and futuristic sounds all easily accessible from an old-school, knobs-and-buttons programming interface.

- 4RU rackmount synth/vocoder with 24-voice polyphony
- 256 programs, 128 timbre templates, 128 master and insert effects templates
- Built-in arpeggiator and 8-note, 32-step sequencer
- 16-band vocoder with formant motion function, 16 formant motion data sets
- Headset condenser mic included for vocoder
- 1/4" analog I/O's, MIDI I/O, USB with Windows XP and Mac OS X compatibility

**KORG****RADIUS**#KORADIAS  
**\$1199<sup>00</sup>**

The Radius is a 24-voice synthesizer featuring Korg's Multi-Modeling Technology (MMT) derived from the flagship OASYS. It offers a variety of synthesis algorithms together with multiple effects, wave shaping, modulation sequencing, and a new comb filter and formant-motion vocoder. 256 programs, each capable of having four discretely-controlled timbres, 32 drum kits, and 16 formant motion sets are combined with audio inputs, effects, step sequencers, and an arpeggiator, resulting in brand new sonic possibilities.

- Configurable 24-voice synthesizer with 49-key keyboard/control module
- Advanced modeled and formant waveforms, ring mod, noise, syncs and more
- 11 waveshaping types, 3 mod sequencers, 2 step sequencers
- Built-in mic with 16-band vocoder, records up to 7.5 seconds of incoming audio
- 9 possible simultaneous effects
- USB connection, Sound Editor/Librarian included





## ACCESS MUSIC

### Virus TI Snow

#ACVTIS  
\$1250<sup>00</sup>

The Virus TI Snow is a compact, robust little desktop synthesizer module targeting the modern laptop musician and producer. It uses the same adventurous sound engine found in the legendary Virus-series keyboards, and its 1000+ plus sounds travel through a maze of Virtual Analog, Wavetable and Granular synthesis oscillators and complex filters. The intuitive navigation surface allows for near-immediate parameter access and programming.

- Compact desktop synthesizer module designed for laptop music production
- Over 1000 Virtual Analog, Wavetable and Granular synthesis sounds
- Total Integration technology for seamless use with sequencers
- Over 6000 free patches available for download
- (2) ¼" TS line inputs, (2) ¼" TS line outputs, MIDI I/O, USB
- Large, backlit LCD display



## KORG

### microKorg BK

#KOMICROKORB  
\$449<sup>00</sup>

The Virus TI Snow is a compact, robust little desktop synthesizer module targeting the modern laptop musician and producer. It uses the same adventurous sound engine found in the legendary Virus-series keyboards, and its 1000+ plus sounds travel through a maze of Virtual Analog, Wavetable and Granular synthesis oscillators and complex filters. The intuitive navigation surface allows for near-immediate parameter access and programming.

- 37-note modeling synthesizer and vocoder with velocity sensitivity
- Limited-edition collector's item with reverse key-color
- 128 programmable presets
- Built-in modulation and delay effects, EQ
- (2) ¼" audio line inputs
- Gooseneck condenser mic with XLR input
- (2) ¼" outputs, headphone out, MIDI I/O

#ACVTIP  
\$2750<sup>00</sup>



## ACCESS

### Virus TI Polar

The VIRUS TI POLAR is a powerful 37-key, 80-voice synthesizer that finally integrates Pro Audio with a musical instrument loaded with 512 RAM patches and 2048 (rewritable) ROM patches. This advanced stage/stand-alone instrument links to your computer with VIRUSControl, a companion software product that ports the unit seamlessly into a host sequencer as a sample-accurate VST/AudioUnits instrument, providing simultaneous 2-way audio, control surface functionality, and MIDI connectivity.

- Innovative integration of a hardware synthesizer into a software environment
- New Wavetable and Amazing Hypersaw oscillator models
- Multi-mode builds impressive layers, splits or polyphonic arpeggiators
- Dual DSP core provides superior low-latency, delay compensated performance
- Studio grade 24-bit/192kHz balanced analog and S/PDIF I/O
- High-speed USB 2.0 compatible

**Virus TI Keyboard** 61-key version of above #ACVTIK..... \$2560.00



## ROLAND

### V-Synth GT

#ROVSYNTHGT  
\$2895<sup>00</sup>

The V-Synth is a 61-key programmable synthesizer with 28-voice polyphony. The unit features a variable-oscillator design and a dual-core engine combining several synthesis modes in real time. In conjunction with Roland's sophisticated controllers and touch screen, physical modeling and waveform manipulation coalesce, creating a genuinely different and highly interactive synthesis experience unique to this instrument.

- 61-key V-Synth with velocity-sensitive keys and Aftertouch
- Dual-core Elastic Audio synthesis engine
- AP-Synthesis acoustic modeling and Vocal Designer Function synth modes
- Time Trip and and D-Beam touchpad and infra-red controllers
- Arpeggiator and built-in multi-effects processors
- Coaxial SPDIF and Optical digital I/O's, (2) stereo ¼" line outputs
- (2) USB ports, MIDI I/O, XLR Mic in with phantom power



## ROLAND SH-201

#ROSH201  
**\$595<sup>00</sup>**

The SH-201 is a 49-key analog modeling synthesizer with a thick, professional sound but logical layout for even the most novice synthesist. Two oscillators generate sound from multiple internal waveforms, including the famous Supersaw waveform, and can even manipulate external audio from CD/MP3 players, etc. Its high-quality effects, combined with 34 arpeggiator patterns, instant hands-on control, and a USB connection make the SH-201 an ideal live or studio performance synthesizer.

- 49-key analog modeling synthesizer
- Hands-on control of all sound creation elements
- Built-in delay, reverb and overdrive effects
- One track recorder captures loop phrases and knob tweaks
- VSTi Editor software included for computer DAW integration
- External inputs (RCA) for audio manipulation



## CLAVIA Nord Modular G2

#CLG2  
**\$1749<sup>00</sup>**

The Nord Modular G2 is a 37-key modular hardware synthesizer system that allows users to build their sound piece by piece from a PC/MAC editor, in a simple and intuitive way, following your desired signal flow. Imagine the way a guitarist connects his pedals and boxes; the G2 provides a wide spectrum of modules consisting of traditional synth building blocks such as oscillators, filters, envelope generators, modern effects, and special-purpose modules. All modules can be connected in any desired structure, audio routed in and out, and stored internally for instant live recall.

- Over 160 Modules in 16 categories
- 32 banks of 128 patches/8 banks of 128 performances
- 32-voice polyphony dependent on Module complexity
- 4 channels of audio input and bussing for processing
- 24-bit/96kHz audio quality

**Modular G2 ENGINE** rack version #CLG2ENGINE.....**\$999.00**



## KORG R3

#KOR3  
**\$649<sup>00</sup>**

The R3 is a 37-key, 8-voice polyphonic modeling synthesizer and vocoder. The sound engine uses proprietary Multiple Modeling Technology to create a rich analog sound, and the unit includes a nice complement of built-in effects, easy-access controls, dedicated indicators, and a flexible arpeggiator. The vocoder section includes a group of 16 easily-customized formant motion data sets.

- 37-key modeling synthesizer and vocoder
- Velocity-sensitive keys, dual-timbre, layering, and keyboard split
- 128 programs, 16 formant motion data sets for custom vocoding
- Built-in arpeggiator and effects processing
- Gooseneck microphone included
- Pitch and modulation wheels, (9) control knobs
- Dedicated display and indicator complement



## ALESIS Micron

#ALMICRON  
**\$399<sup>00</sup>**

Featuring the same sonic quality as its big brother ION, the Micron is a compact 37-key 8-voice polyphonic Analog Modeling Synthesizer that offers great analog realism in a lightweight, portable keyboard. Up to 20 filter types are included, along with 2 LFO's with multiple wave shapes and sample and hold. The Micron is 32-part multi-timbral and offers a programmable step sequencer, arpeggiator, rhythm sequencer for drum kits, and dynamic real-time phrase sequencer.

- 37-key Analog Modeling Synthesizer with 8-voice polyphony
- Over 500 presets programs, 200 preset pattern sequences and 250 preset drum rhythms
- Fully compatible with ION programs
- Balanced 24-bit audio I/O
- High-resolution, full 360° knobs
- Up to four high-quality effects at once



**CLAVIA**  
**Nord Stage 88**

#CLNS88  
**\$3299<sup>00</sup>**

The Stage 88 is a digital piano that combines classic organ models, electric and acoustic pianos, and a powerful synth section into one comprehensive, professional performance keyboard. Organs include the Hammond B-3, Vox Continental, and Farfisa. Pianos range from the Clavinet, Wurlitzer and Rhodes, to an acoustic Steinway D, Yamaha C7 and Upright Swedish Piano Factory. And finally, the synth section offers you three types of synthesis, Subtractive, FM, and Wavetable, all with simple, expressive control of the parameters necessary for building dynamic layers and leads.

- 88-key, medium-weighted hammer action
- 3 classic organs, 4 acoustic pianos, 3 Rhodes, Wurlitzer, Clavinet, Yamaha CP80
- Powerful synth with 10 analog waveforms, up to 3 operator FM synthesis, and 32 wavetables
- Comprehensive effects section
- USB connection for fast, simple updates
- 40 lbs



**CLAVIA**  
**Nord Electro 2**

#CLNE61  
**\$1349<sup>00</sup>**

The Electro 2 is designed to provide the best emulations of traditional electromechanical keyboard instruments available. It combines the energy of a B-3 organ and five carefully multi-sampled electric piano instruments faithfully into a lightweight chassis weighing a mere 20 pounds. The Rhodes Mk I Stage and Suitcase Pianos, Wurlitzer 200A, and custom modified Clavia Electric Grand Model G and Mega Clavinet D6 are all provided, with the Mega Clavinet D6 offering every filter and pickup variation of the original.

- Modeled B-3 and 5 multi-sampled electric pianos (additional Stereo Grand Piano included)
- 61 or 73-key versions with true, responsive feel
- Modeling of unique frequency characteristics throughout entire dynamic range
- Authentic digital modeling of the B-3 chorus, vibrato, and tone wheel tuning
- USB connection for quick downloads of new piano samples
- 20 lbs



**KORG**  
**CX-3**

#KOCX3  
**\$1799<sup>00</sup>**

Since its introduction in 1979, the CX-3 has been the perfect choice for those looking for the sound and feel of a true tonewheel system without the high expense, regular maintenance scheduling, and difficult transportation logistics of a full B3. Korg has constantly been refining this instrument, and the latest revision adds re-balanced drawbars, an improved Chorus/Vibrato emulation, selectable key triggering, and a noise parameter to get even closer to the sound and feel of the real thing.

- 61-key tone wheel organ modeling system
- Two sets of nine drawbars and "waterfall" keyboard
- Split keyboard mode for Upper and Lower zones
- Natural wood case for a timeless appearance
- MIDI in, out, and thru

**BX3** dual-manual version of above #KOBX3..... **\$3599.00**



**ROLAND**  
**VK-8**

#ROVK8  
**\$1595<sup>00</sup>**

With its authentic solid wood cabinet and vintage "waterfall" style keys the VK-8 delivers the warm, rich sound characteristic of yesterday's organs. Its distinct aged look, familiar control layout, and responsive tone make the VK a very inviting and enjoyable instrument to play. Players will also appreciate having a good selection of high-quality onboard instrument sounds such as electric/acoustic pianos, strings, bass, and synths to add to its versatility.

- 61-note combo organ with defeatable velocity-sensitivity
- Sophisticated rotary speaker modeling with overdrive effect
- Authentic solid wood cabinet and vintage keys
- (2) MIDI inputs for second keyboard or optional pedalboard

**VK-88** dual-manual version of above #ROVK88..... **\$4395.00**  
**PK-7A** MIDI pedalboard #ROPK7A..... **\$1295.00**





**CLAVIA**  
**Nord Electro 2 Rack**

#CLNER  
**\$1099<sup>00</sup>**

Most general sound modules have a hard time truly recreating the complex nature of the electromagnetic keyboards that have become staples in modern popular music. The Nord Electro 2 Rack is a dedicated sound module that concentrates on bringing you the finest B-3 organ, electric piano, clavinet and acoustic piano reproductions without the hindrance of cluttered menus. The front panel electric drawbars feature 9 user-configurable settings, and the effects section includes everything from overdrive to ring modulation to complement the onboard sound set.

- Electromechanical keyboard and Tonewheel organ module
- Complete B-3 organ modeling with full rotary speaker simulation
- Rhodes, Wurlitzer and Clavinet programs
- Split mode simulates upper and lower organ manuals
- Features a very flexible effects section
- 48 user memory locations for storing complete setups

**ROLAND**  
**VK-8M**

#ROVK8M  
**\$895<sup>00</sup>**

The VK-8M Organ Sound Module puts Roland's acclaimed Virtual ToneWheel organ sound in a convenient desktop unit with nine harmonic bars and retro-style wood panels. COSM Amplifier and Rotary Speaker Modeling further complement these authentic sounds, while an audio input and Active Expression feature let players fade in an external tone with an optional pedal. Players can also dive into more detailed sound parameters like leakage level and rotary woofer speed to dial in their own signature sound.



- Desktop organ module with acclaimed Virtual Tonewheel sound
- 36 User registers for storing custom sounds
- 4 COSM amp types w/overdrive & rotary speaker modeling
- Compact design fits into any keyboard setup

**EV-5** optional expression pedal #ROEV5..... **\$74.95**



**ALESIS**  
**DM5**

#ALDM5  
**\$349<sup>00</sup>**

For drummers and MIDI composers on a budget, the DM5 offers professional performance features and an excellent selection of drum, percussion, and special effect samples. It includes an ultra-fast trigger-to-MIDI converter with 12 trigger inputs, 5 programmable parameters for each trigger, 21 programmable drumsets, and four audio outputs for discrete processing and control. The large LCD makes programming a breeze and it puts over 550 sounds into a single rack space with many sounds recorded in true stereo. The Expanded Dynamic Articulation feature allows drum sounds to change volume, tone, and pitch, depending on how hard they're struck.

- 16-voice drum/percussion sound module
- (4) 1/4" outputs for discrete processing and control
- 21 programmable drumsets
- Large LCD screen
- An excellent drum replacement tool for mixing
- Random Sample feature adds variation to static parts
- MIDI in, out/thru
- Over 550 sounds including stereo samples with ambience
- 1/4" headphone output with level control
- 12 Trigger input jacks with 5 adjustable parameters



**YAMAHA**  
**VL70-m**

#YAVL70M  
**\$599<sup>00</sup>**

Yamaha was one of the first companies to introduce the concept of "physical modeling" to the marketplace and the monophonic VL70-m is still recognized as a very expressive sound generator, especially when used with a breath controller or wind synthesizer. Complex vibrations and resonances are mathematically recreated to produce tones and sonic artifacts that lend breath and elastic playability to its programs. The optional breath controller adds an extra level of performance control.

- Monophonic physical modeling module
- (2) 1/4" audio outputs with MIDI in, out and thru
- Front panel wind and breath controller inputs
- Large graphic display and built-in effects
- Expert Editor gives full access to all physical modeling parameters
- Analog Editor provides analog-style graphical interface
- Visual Editor uses easy-to-understand palettes and buttons
- Use from a keyboard, MIDI guitar or Wind controller

**BC3A** optional breath controller #YABC3A ..... **\$89.95**



## MUSE Receptor Rev C2

#MURC2  
**\$1999<sup>00</sup>**

The MUSE Receptor Rev C2 is a versatile 24-bit/96k rack-mountable multi-timbral sound and effects module that runs standard VST instruments and effects. It combines the power of a computer with the ease-of-use, portability, and reliability of dedicated synth and effects hardware. Up to 16 simultaneous VST instruments and 57 VST effects sources are routed within its mixer-like architecture. The Receptor defies obsolescence with new instrument and effects plugins be created daily.

- Powerful multi-timbral sound module for VST instruments and effects
- Convenient, intuitive operation for both live or studio use
- 16 channels of audio and 57 effects at once
- Excellent sonic quality with 24-bit/96kHz converters
- Ethernet and MIDI I/O
- Balanced 1/4" inputs and outputs
- Front panel high-Z instrument input
- Coaxial S/PDIF digital I/O
- Windows And Mac compatible editing software
- 2 U rack mount chassis



## ACCESS MUSIC Virus TI Desktop

#ACVTID  
**\$1995<sup>00</sup>**

The Virus TI Desktop is a professional 80-voice polyphonic programmable desktop/rack mount synthesizer. The synth, though digital, exhibits a hands-on, old-school analog work surface, with knobs and switches forever, and a fat, bottom-rich sound, complementing cutting-edge features such as 24-bit/192kHz resolution along with USB and SPDIF digital connectivity. The unit also features the obligatory programmable arpeggiator, proprietary Virus Sound Engine synthesis, and abundant multi-effects.

- Removable wood-finish side panels or rack-ears for mounting versatility
- Dual-DSP system typically accommodates over 80 stereo voices
- Analog 1/4", MIDI, SPDIF, and USB connectivity
- 9 parallel oscillators per voice, 3 LFO's
- 2 multi-mode filters plus analog filter
- 2,048 ROM patches, 512 RAM patches
- 129 built-in programmable multi-effects
- VIRUSControl VST for plug-in-like sequencer integration



## KURZWEIL PC2R

#KUPC2R0  
**\$1415<sup>00</sup>**

The PC2R puts the same sonic quality and life-like sound set of the acclaimed PC2 series into a single-spaced, 64-voice (128-voice expanded) polyphonic sound module. Providing some of their best sounds available, the PC2R combines the outstanding Triple Strike Piano, KB3 Tone Wheel mode, built-in Orchestral ROM with the KDFX multi-effects processor and 24-bit digital co-axial output. The result: an ideal rack for delivering the truly lush, dynamic sounds required by both professional composers and performers.

- 64-voice polyphonic w/over 500 programs and 64 setups internal
- Voices include: piano, electric piano, strings, leads, woodwinds, synths, bass, percussion
- Balanced 1/4" outputs and bit-selectable AES/EBU or S/PDIF digital output on co-axial connector
- 4-programmable zones split/layered
- Fully programmable KB3 organ mode
- Mastering quality 24-bit dual effects engine via KDFX



## YAMAHA MOTIF RACK ES

#YAMRES  
**\$1099<sup>00</sup>**

Featuring the same extensive waveforms, expandability, and 128-voice polyphony as its keyboard brother, the RACK ES provides a huge number of musically-inspirational tools for Hip-Hop, R&B, Electronica, and more. More than 1,700 arpeggiator grooves and patterns, an expandable Modular Synthesis System, and seamless DAW integration for complete control of RACK voices, editing, and effects make the RACK ES a pivotal component of a professional production studio.

- Expandable voice, effects and polyphony via two Modular Synthesis Plug-in slots
- Over 1,200 voice and drum kits accessible via front panel
- 8 simultaneous effects with 2 Master effects
- 18 different synthesis filter types
- Studio Connections Recall Editor for seamless DAW integration
- 24-bit stereo S/PDIF coaxial and optical connection
- 128 programmable performances
- Each 16 part with its own 3-band EQ



## ROLAND Fantom-XR

#ROFXR  
**\$1395<sup>00</sup>**

The Fantom-XR is a professional 128-voice rackmount synthesizer that combines full 16-bit .WAV and .AIFF sample import/playback capabilities with an already huge selection of internal sounds and further expansion via 6 SRX expansion slots. Samples can be edited, stretched, and processed utilizing powerful multi-effects, COSM modeling, and mastering dynamics. Ideal for both studio and live use, the XR also adds a programmable Arpeggiator and Rhythm Pattern generator for more creative potential.

- 128-voice sampling synthesizer with expressive 4-tone stereo multiplex synthesis
- 16MB sample memory expandable to 528MB
- Internal audio phrase recording and RAM playback
- Full-featured sample editor with sample conversion utility (PC/Mac)
- USB file transfer and optional PC Card storage up to 1GB
- 3 Multi-fx processors, reverb, chorus and mastering effects
- Front panel headphone jack
- Back-lit LCD screen
- 1U rackmount



## EDIROL SD-20

#EDSD20  
**\$299<sup>00</sup>**

Now there's a compact, portable, USB bus-powered MIDI sound module perfect for your laptop or desktop recording needs, the Edirol SD-20. Its compact size and streamlined design makes it easy to connect and create music anywhere while directly accessing programs from your controller or keyboard. It gives you a wide enough range of sounds to cover almost any task, and with its USB and serial ports this box will work with your computer no matter what its age.

- USB bus-powered MIDI 64-voice sound module
- MIDI input with USB and serial connections
- Optical S/PDIF output and (2) RCA analog outputs
- Includes AC adaptor and driver CD-ROM



## KETRON SD2

#KESD2  
**\$380<sup>00</sup>**

The SD2 Orchestral Wizard is a pocket-size sound module designed to be used with your computer, master keyboard, MIDI guitar, or just about any other instrument with MIDI output. It features a new Stereo Grand Piano, a large selection of orchestral voices and a library of drum and percussion loops to fit every style. This great "all-in-one" sound source can be used to greatly enhance standard MIDI files as well as compliment your home studio compositions and recordings.

- Compact 32-channel sound module
- Multi effects include reverb, chorus, delay, and rotor slow/fast
- 290 orchestral sounds
- 292 GM sounds • Over 1,000 percussive sounds



## KORG M3-M

#KOM3M  
**\$1999<sup>00</sup>**

The M3-M is a professional rackmount music workstation and sampler with 120-voice polyphony with VST, RTAS, and Audio Units plug-in capability. The sampler, effects and internal sounds are all top-notch, drawing on Korg's proprietary Karma and Oasys system engines. The highly programmable unit features numerous trigger pads and control sliders, and the large Touchview display also functions as an X-Y controller.

- Professional rackmount synth and sampling workstation module
- 1028 multi-samples and 1606 drum samples
- 1664 preset user locations, 170 built-in effects
- 64MB of sample RAM expandable to 320MB
- 8 trigger pads, 8 sliders, Touchview screen
- (2) 1/4" TS phone analog inputs, Toslink SPDIF optical I/O MIDI I/O
- (2) 1/4" TS phone Main outs, (4) 1/4" TS phone individual outs, USB



**KURZWEIL****SP2X**

The SP2X is an 88-key stage piano with weighted hammer-action keys and 64-voice polyphony. The unit features the highly realistic sound of Kurzweil's Triples Strike Grand Piano, along with a useful meat-and-potatoes complement of strings, mallets, electric pianos, and 64 pre-programmed, multi-genre drum grooves. The SP2X is also a viable controller keyboard, offering 4 programmable zones and 4 assignable rotary encoders.



#KUSP2X  
**\$1251<sup>00</sup>**

- 88-key stage piano/controller with fully-weighted hammer-action keys • Adjustable velocity-sensitivity
- 64-voice polyphony, 64 presets, 16-part multi-timbral
- 16 user MIDI setups with 4-zone split/layer control and 4 rotary encoders • Built-in reverbs, delays, compression and combination effects
- (2) 1/4" TRS phone Main line outs, headphone output
- MIDI I/O/Thru, USB Data port

**YAMAHA**  
**CP33**

#YACP33  
**\$1299<sup>99</sup>**

The CP33 draws on Yamaha's many years of professional stage piano production to create an instrument that combines the best features of their previous top models with some added bonuses. For a fully-weighted action keyboard, it is both compact and lightweight, with an uncompromised acoustic piano sound and truly responsive feel. It also features USB connectivity as well as a good selection of other useful sounds such as electric pianos, strings, and organs. The Mono Piano setting is designed specifically to stand out during live performance.

- 88-note, professional fully-weighted stage piano
- Compact, light, and portable with 28 onboard sounds
- Independent control of two external tone generators
- Panel Lock prevents inadvertent control changes

**M-AUDIO****Pro Keys 88**

#MAPK88  
**\$599<sup>95</sup>**

The Pro Keys 88 is a hammer-action 88-key digital piano with the professional sound and features of keyboards costing far more. Fourteen of the most popular instruments are sampled using 64MB of sample ROM, with 30MB being dedicated to a dynamic 3-layer Yamaha C7 Grand. Loaded with features, it offers 126-voice polyphony, dedicated MIDI controls, a USB interface, and single, split, and layer capabilities with three velocity levels.



- 88-key fully-weighted hammer action with 126-voice polyphony
- Sounds include: Yamaha C7, DX7, Hammond B3, Fender Rhodes, Wurlitzer, Clavinet, Strings and more
- 3 reverb spaces, chorus, and tremolo
- Dedicated volume for master, layer, and split
- Dedicated MIDI controller buttons and USB interface

**ProKeys 88SX** 88-key semi-weighted version with 7 sounds & USB interface #MAPK88SX....\$399.00

**CASIO**  
**Privia PX-110**

#CAPX110  
**\$499<sup>95</sup>**

The PX-110 represents a remarkable value in an affordable digital piano. Its slim design and light weight make it very portable while its Tri-element ZPI sound source with separate high, medium, and low-velocity layers adds to its responsive piano tone. The scaled hammer action keyboard is very solid and really allows you to dig in during those fortissimo passages, while the Bass Reflex System delivers clear low frequency even at higher volumes. In addition to grand piano tones, the PX-110 also includes sounds like strings and pipe organ that can be layered or split across the keyboard.

- 88-note Scaled Hammer Action
- 32 notes of polyphony
- Includes 20 built-in rhythms
- Auto-Accompaniment function
- High-quality stereo sampled piano
- Perfect for an apartment or dorm room
- 8 digital effects plus brilliance
- 1 Song, 2-Track Song Memory
- Includes: SP-3 sustain pedal & AD-12 AC adapter
- MIDI In/Out and (2) pedal inputs

## KURZWEIL PC1X

#KUPC1X  
**\$1646<sup>00</sup>**

Featuring the same outstanding quality sound set (less KB3 mode) of the Kurzweil PC2 at a remarkably affordable price, the PC1X is a powerful 88-note, 64-voice polyphonic, weighted-action performance controller. The sound set ranges from a comprehensive collection of drum kits, world percussion, and synthesizers, to musically expressive pianos, strings, woodwinds and more. Truly a superior-sounding studio controller and performance instrument for professionals and beginners alike.



- Over 500 programs with 64 factory/128 programmable setups
- Expressive 4-MIDI zone controller, velocity-sensitive w/aftertouch
- Expandable via ROM 2 (Classic Keys)
- Dual-effects engine derived from award-winning KDFX effects board
- Fully-assignable switches, sliders, pedals, wheels, and optional ribbon controller
- 50 lbs



- Sleek, stylish 88-key digital piano with adjustable velocity sensitivity
- Over 300 voices and 60+ built-in effects
- Built-in 14-watt stereo amplification and dual 4.7" speakers

- 9 drum sets and 80 rhythm types
- Damper, soft and sostenuto pedal inputs
- (2) 1/4" inputs, (2) 1/4" outputs, (2) stereo 1/4" headphone outs, MIDI I/O, USB

**FP-4-WH** White version #ROFP4WH..... **\$1295.00**

## ROLAND FP-4

#ROFP4BK  
**\$1295<sup>00</sup>**

The FP-4 is a stylish 88-key digital piano suitable for home use. The keyboard features adjustable velocity sensitivity, 128-voice polyphony, built-in speakers, a 3-track sequencer for composition, and a large collection of high-quality sounds and effects processors. The Session Partner learning feature provides a versatile set of background rhythms to play along with.

## ROLAND RD300GX

#RORD300GX  
**\$1395<sup>00</sup>**

Similar to its high-end brother, the RD300GX offers 128-voice polyphony, an 88-note individually-sampled grand piano, and hundreds of Roland's best instrument sounds into a musically expressive, great-feeling keyboard that's easy to operate and easy to transport. The RD300SX's Progressive Hammer-Action mechanism is more compact and lightweight, making it probably the lightest, most powerful digital piano in its class, ideal for gigging musicians and educational learning labs.



- 64MB of some of Roland's best instrument sounds, 480 tones expandable via 2 SRX expansion slots
- 88-note, more compact, lightweight Progressive Hammer-Action mechanism
- Dedicated function buttons and knobs, and handy Setup mode for quick storing and recall
- 78 multi-effect types for subtle or drastic tone coloration • USB/MIDI interface for easy computer connectivity • 34 lbs



- 64MB of some of Roland's best instrument sounds, 480 tones expandable via 2 SRX expansion slots
- 88-note Progressive Hammer-Action effectively simulates a real grand-piano's action
- Powerful internal effects processing with reverb, chorus, and 65 insert effects, Master EQ
- 85 rhythmic patterns with 45 arpeggiator styles
- Rugged cabinet build with large graphic LCD and balanced outputs • 53 lbs

## ROLAND RD700GX

#RORD700GX  
**\$2395<sup>00</sup>**

The RD700GX is an 88-note, 128-voice Progressive Hammer-Action Keyboard loaded with some of the best stereo-sampled piano and instrument sounds available. Its intuitive operation features a switch for instant one-touch piano performance operation, realistic tone-wheel organ sounds with graphical editing, and dedicated knobs and sliders for quick sound shaping and editing. Ideal for performers needing simple operation, great sound, and one of the most realistic, responsive keyboard actions available, the RD700SX is sure to please.



#YAN100  
**\$2299<sup>99</sup>**

**YAMAHA**  
**Nocturne**  
**N100**

Drawing on its vast experience with both acoustic and electronic instruments, Yamaha has designed an instrument that strives to bring all of the dynamic sounds and performance nuances of an actual 9-foot concert grand into a compact digital piano. Its modern design yields a very compact footprint, while retaining an expansive sound, delivered through speakers conveniently tucked into the rear cabinet and pedal frame. There are 64 notes of polyphony, 10 of Yamaha's best keyboard voices, 50 built-in songs, plus a spacious digital reverb. Even with all of these features the N100 does its best to keep the advanced technology transparent while delivering a truly inspiring digital piano.

- 88-note graded hammer action keyboard
- 3-level Dynamic Stereo Sampling Advanced Wave Memory
- Sleek design with back-lit touch controls
- (3) piano-style foot pedals with half-pedal effect
- Built-in 20Wx20W stereo amplifier and speaker system



#YAP85  
**\$599<sup>99</sup>**

**YAMAHA**  
**P85**

The P85 is a slim and lightweight digital piano that features high-quality sound and expressive Graded Hammer Action in an affordable package that can go with you almost anywhere. Besides the fantastic piano presets it also features extra sounds such as organs, strings, harpsichord and other voices that can be layered for extra richness. You can record your performances with the built-in song recorder and listen back through its dual 6-watt stereo speaker system.

- 88 note fully-weighted Graded Hammer Action keyboard
- 64 voice polyphony with 50 piano preset songs
- Reverb/chorus effects and MIDI I/O
- 1-track song recorder with metronome
- Includes music rest, sustain pedal, and AC power adapter

**P85S** silver version of above #YAP85S ..... **\$599.00**  
**L85** matching stand black # YAL85 ..... **\$99.99**  
**L85S** matching stand silver YAL85S ..... **\$99.99**



#YAP140  
**\$1199<sup>00</sup>**

**YAMAHA**  
**P-140**

The P-140 is an attractive 88-key 64-voice digital piano with an advanced Graded Hammer Action. With the subtle touch response of a real piano, the P-140 expressively controls three separate layers of stereo samples, not just the volume, but the harmonic content as well. A fourth layer recreates a piano's sustain resonance when the damper pedal is pressed. Its 14 voices are amplified by built-in 6-watt speakers, processed with reverb and chorus, and can be recorded into 3 songs capable of 2 tracks each.

- 88-key digital piano with 64-voice polyphony and a Graded Hammer action
- 3-layer Dynamic Stereo Sampling with 4th (resonance layer)
- 14 distinct voices with 3 variations each • Dual 6-watt speakers
- 2-track recorder great for practicing songs • 39 lbs

**P-140S** silver version of above #YAP140S ..... **\$1199.00**  
**L140S** stand for silver version #YAL140S ..... **\$120.00**  
**L140** stand for black version #YAL140 ..... **\$120.00**



#YACP300  
**\$2199<sup>99</sup>**

**YAMAHA**  
**CP300**

The CP300 is an 88-note, 128-voice Graded Hammer Action digital piano provided with a complete palette of sound, 50 Panel Voices, 480 XG voices as well as a meticulously-sampled stereo grand piano. Each sample is expressed according to the delicacy and expression of touch, accurately emulating a real acoustic piano. The CP300 also features a 16-track Song Recorder, built-in effects, and a powerful 60-watt sound system, ideal for both performers and composers.

- 88-note, 128-voice polyphony with realistic Graded Hammer Action
- 50 Panel Voices, 480 XG voices and Dynamically-Sampled acoustic piano
- 16-track Song Recorder w/223 songs and internal flash memory
- Digital reverb and effects, layer and split mode, PC serial interface
- Powerful 60-watt speaker system • 71 lbs



## ROLAND RP-101-PAK

The RP-101-PAK is an 88-key piano for the home with a handsome wood-finished console sporting the look and feel of an upright piano and the sound of a baby grand. The unit's extensive feature set includes a realistic progressive hammer-action keyboard, highly nuanced and detailed stereo piano samples, 3 built-in pedals just like an acoustic piano, and built-in 50-watt stereo amplification with a pair of robust 4.7" speakers.



#RORP101MH  
**\$1495<sup>99</sup>**

- Stylish 88-key digital piano for the home with upright piano console design
- Realistic piano keyboard action with 3 levels of adjustable sensitivity
- 50-watt internal stereo amplification and dual 4.7" stereo speakers
- 65 pre-programmed play-along songs
- 17 sounds include pianos, organs and strings
- Internal reverb effect and built-in metronome

## YAMAHA YDP223

Built into an attractive rosewood finished cabinet with twin 20-watt powered speakers, the Yamaha YDP223 is an 88-note, 64-voice digital piano with a realistic Graded



#YAYDP223  
**\$1599<sup>99</sup>**

Hammer Action and 14 acoustic and electric instruments including a dynamic stereo concert grand piano. Featuring built-in effects, a 2-track song recorder, and twin amplifiers producing 20 watts per side, the YDP223 fills the room with a sound that is perfect for both home entertainment and instructional use.

- 14 sounds including Stereo Grand Piano sample
- 88-note, 64-voice polyphonic
- Graded Hammer Action emulates touch response in upper and lower registers of a real acoustic piano
- 50 song preset with accompanying songbook
- MIDI and TO HOST serial connectors for computer notation, composing and song recording

## ROLAND MP-70

The Roland MP-60 is an 88-note progressive hammer-action digital piano capable of providing 64-voice polyphony for expressive stereo sampled pianos, electric pianos, harpsichord, strings, acoustic bass, and more. Built into a black satin cabinet with a high-quality sound system, the MP60 also features reverb, chorus, and Sympathetic Resonance Effects, a built-in 2-track recorder with metronome, dual headphone jacks, and a Split and Layer mode for independent or simultaneous 2-voice playback.



#ROMP70  
**\$1495<sup>00</sup>**

- Ideal first piano for the beginning student
- 65 preset songs and 2-track Song Recorder w/metronome
- High-quality stereo sound system w/dual headphone jacks and MIDI I/O • Solid black cabinet with damper, sostenuto, and soft pedals for more dynamic feel • 92 lbs

## ROLAND FP-7

The FP-7 is an 88-key digital piano with 128-voice polyphony, designed for use in the home. The keyboard features built-in stereo amplification and speakers, 88 full-sized keys with 100 levels of adjustable touch sensitivity, a large library of realistic, GM2 system voices, and a 3-track "scratchpad" sequencer. The FP-7 is loaded with over 60 different multi-effects, and ships with Windows-based SONAR LE software for MIDI sequencing on a PC.



#ROFP7  
**\$1595<sup>00</sup>**

- 88 keys with adjustable touch sensitivity
- Large 300-voice "meat-and-potatoes" sound library
- 80 Session Partner backup rhythms with 2 variations each
- Over 60 built-in effects with reverb, EQ, chorusing
- Pedal inputs for Damper, Soft and Sostenuto
- ¼" and 1/8" Analog, MIDI, and USB I/O connectors
- Audio Key .WAV file playback • Large back-lit LCD screen

## ROLAND G-70M

#ROG70M  
**\$395<sup>00</sup>**

The G-70M is an unparalleled interactive music workstation that incorporates technologies from across the Roland product range. Its sound engine uses the largest internal wave ROM in Roland keyboard history and the arranger section includes 285 completely new styles with the latest intelligent chord-voicing technology. The weighted professional action gives a responsive feel and the 9 front panel sliders and 3-D animated drawbars take full advantage of the onboard Virtual ToneWheel system. There is also powerful lineup of vocal assistant features including the Vocal Harmonist, Auto Pitch Correct and Vocoder.



- 76-key professional arranger/workstation with aftertouch
- Professional 16-track sequencer
- Color LCD touchscreen
- Music Assistant database, Quick Search and Finder features
- USB connector for file exchange and MIDI transfer to PC



## KETRON SD1 Plus

#KESD1P  
**\$3308<sup>00</sup>**

The SD1 Plus is a 76-key programmable arranger-workstation keyboard with 64-voice polyphony and a hi-tech, professional appearance. Equally at home on stage or in the studio, the unit is equipped with a large collection of GM, drum set, and synth presets, built-in multi-effects, a 16-track sequencer, and almost 300 accompaniment styles. The keyboard also features a phantom-powered microphone input, and a built-in 16MB sampler.

- Half-weighted velocity-sensitive keys with Aftertouch
- Realistic sampled instrument voices
- Pitch and modulation wheels
- Built-in 6GB IDE drive and 3.5" floppy drive for storage
- Vocalizer function for keyboard-controlled harmonies with microphone
- Digital drawbars for realistic organ sound control
- XLR and 1/4" mic inputs, 1/4", MIDI, and computer connectors

## KORG PA800

The PA800 is a professional arranger that combines the enhanced sonic capabilities of Korg's powerful sound engine technology with the performance and production features of their established line of professional arrangement keyboards. The Graphical Colour Touch Screen helps to make playing this power-packed instrument an intuitive, fast, and foolproof experience while the built in TC Helicon processor provides EQ, effects, and stellar 3 voice harmonization to your vocals. It provides a huge collection of musical styles created by top musicians from around the world as well as the most advanced chord recognition system in the industry.



#KOPA800Q  
**\$2699<sup>00</sup>**

- 61-key professional arranger keyboard with aftertouch
- Easy and Expert modes with onboard multilingual Help System
- On board sampler for importing and editing .WAV, .AIFF and Korg format files
- Features SongBook Musical Database
- (2) USB Host and (1) USB Device connection



## YAMAHA Tyros 2

#YATYROS2  
**\$3495<sup>00</sup>**

The Tyros 2 is an interactive workstation that draws on Yamaha's many years of experience in the professional keyboard world. It combines the quality of sound, stylistic detail and ease of use of their Clavinova line with the incredible editing control over sounds and sequences of the Motif. Add to this the same onboard mixing and DSP effects technology that is found throughout their pro line, and you have a very powerful system in a portable package.

- 61-note interactive arranger workstation
- Smooth and responsive FSX keyboard action
- Score, lyric and text display
- USB port for data exchange and MIDI control
- Import audio samples and waveforms

## YAMAHA PSR-S700

#YAPSR5700  
**\$999<sup>99</sup>**

The PSR-S700 is a 61-key arranger-workstation keyboard with 96-voice polyphony, built-in stereo speakers, and a large, hi-res LCD screen displaying both lyrics and score. The large 800-plus collection of realistic, AWM stereo-sampled sounds and Mega-Voice accompaniment styles are fun to play and easily-accessed. The keyboard is also equipped with a LAN connector for direct Internet access sans computer, allowing for MIDI file download from Yamaha's Internet Direct Connection service.

- Touch-sensitive keys
- 16-track, 30,000-note internal sequencer
- Music Finder with over 1,000 preset keyboard setups by song title
- 205 preset auto-accompaniment styles in 11 categories
- 34 Reverb, 29 Chorus and hundreds of DSP effects presets
- Programmable Organ flute function for custom organ sound creation



- Pitch and mod wheel controllers
- 1/4", MIDI, USB and LAN I/O connectivity

## ROLAND EXR-46 OR

#ROEXR46OR  
**\$999<sup>00</sup>**

This powerful addition to Roland's arranger line focuses on the sounds and styles of the Orient with dozens of new sounds, drum kits, phrase samples and pre-programmed patterns from the Far East, Turkey and various Middle Eastern and Arabic regions. For the highest level of authenticity this machine was designed in collaboration with musical masters from each stylistic region. And now performing and programming drum/percussion parts is made easy with its automatic Drum-Pad mapping capabilities.



- 61 key velocity sensitive keyboard
- 64 voice polyphony with 19 part multitimbrality
- Large backlit custom display
- 12 Oriental Scale buttons
- 16 track recorder with 4 easy modes



## KETRON SD5

#KESD5  
**\$2299<sup>00</sup>**

The SD5 is a 61-key portable arranger-workstation MIDI keyboard with 64-voice polyphony, built-in stereo speakers with dual 22-watt stereo amplification, and a large back-lit LCD screen. The keyboard features a large collection of realistic orchestral and percussion sounds, 2MB of sampling RAM, and a set of 10 digital drawbars for realistic organ performance. The surprisingly lightweight unit offers an intuitive interface and professional sound quality.

- 61 semi-weighted velocity-sensitive keys with Aftertouch
- 1,000-plus percussion sounds, 292 orchestral voices
- 202 auto-accompaniment styles with 4 arranger functions
- 60 Reverb, Chorus and other DSP effects presets
- 13 tunable Arabic scale setups
- Microphone input and output with dedicated volume control
- Pitch and modulation joystick controller
- Built-in hard drive and 3.5" floppy drive

## KORG PA50

#KOPA50  
**\$999<sup>00</sup>**

The PA50 combines enhanced sequencing functions, powerful performance features, a custom back-lit LCD, comprehensive arranging tools and impeccable sound quality. Included with its 660 editable sound programs is a set of very expressive solo instruments, sampled with a natural vibrato. Four studio-quality effect processors are available and feature 89 different effect types. Four assignable pads, an assignable footswitch, the joystick, sync start, fade in and out, tap tempo, accompaniment reset and other front panel functions are available at your fingertips.



- 61-key professional arranger/workstation
- Traditional real-time and step time sequencing
- Backing sequencer captures 8 tracks of Style accompaniment
- Two dual cone speakers with twin 15-watt amplifiers



## YAMAHA PSR-S900

#YAPSR900  
**\$1599<sup>99</sup>**

The PSR-S900 is a 61-key arranger/workstation keyboard with 128-voice polyphony, 12W stereo amplification and speakers, and a large crystal-clear LCD screen. The unit features hundreds of realistic sampled AWM or XG sounds, MegaVoice accompaniment technology with authentic sounds and styles, and USB audio recording direct to a USB storage device. The on-board LANconnector allows for direct Internet access to download MIDI files or sounds.

- Touch-sensitive keys
- 872 realistic sampled AWM and XG voices
- 19 drum kits
- 305 accompaniment styles
- Vocal Harmony feature generates backing vocals from mic input
- Pitch and mod wheels, 4 multi controller pads
- 6 Effect Blocks with reverb, chorus and multi-effects
- 1/4" audio and pedal inputs, MIDI, USB and LAN connectors

## CASIO PX-575CS

#CAPX575R  
**\$799<sup>99</sup>**

The PX-575CS combines Casio's Auto Accompaniment technology with fully-weighted piano action and a superb sound. It hosts a selection of 166 rhythms with a wide selection of styles, and its generous back-lit LCD can displays song lyric information in large easy to read lettering. The microphone input has its own adjustable volume level and the built in USB port makes song transfer to and from your PC quick and easy.



- 88-key fully weighted auto arrangement keyboard
- SmartMedia card slot for song storage
- Compact and lightweight design
- View the lyrics of Standard MIDI Files as they play
- Built in dual speaker sound system



**KETRON****VEGA**

The Vega is a 61-key MIDI arranger keyboard designed to accommodate musicians performing Oriental music, featuring a 12-button Oriental scale converter right on the front panel. The sound engine is packed with sounds and styles from a variety of Oriental music traditions, and 4 auto-arranger functions with intros, fills, and endings. The unit is equipped with stereo speakers and amplification, built-in effects and ample connectivity.

- 61 velocity-sensitive keys
- 12-button Oriental scale converter
- 450 Oriental percussion sounds, 27 Oriental sounds

#KEVEGA  
**\$2060<sup>00</sup>**

- 1,000 GM and Live Percussion sounds
- 172 internal auto-accompaniment styles, 45 Oriental styles
- 60 DSP effects presets

- 1/4" mic/line and headphone connectors, MIDI In/Out/Thru
- 4-way joystick controller
- Built-in 3.5" floppy drive

**YAMAHA**  
**YPG-225**

The YPG-225 is a portable 76-note keyboard with 32-voice polyphony, a built-in, 12-watt stereo amplifier, and a pair of 2-way bass-ported stereo speakers. The keyboard offers a large, high-quality library of AWM sounds, including a realistic stereo-sampled Grand Piano with its own access button. Built-in digital effects processors and a Master 5-band EQ are available, along with a 6-track sequencer and the 30-song Yamaha Education Suite.

- 76 keys with Touch Response
- 489 GM- and XGLite-compatible voices
- 30 preset songs
- Pitch-bend wheel

- Yamaha Education Suite personal tutorials
- Chord Dictionary displays notes and chord names

- 1/4", MIDI, and USB connectors
- D-cell battery or AC power
- Built-in reverb, chorus, and harmonizing

#YAYPG225  
**\$319<sup>99</sup>**

**CASIO****WK-3800**

The WK-3800 is a 76-key, 32-voice polyphonic portable keyboard with a 10,000-note, 6-track sequencer, 182 rhythm accompaniments, 400 DSP effects like reverb, chorusing, and EQ, and 620 GM preset sounds including pianos, synths, drawbar organs and drum kits. The unit also comes with 2-way bass-reflex stereo speakers, 4MB of sample flash memory, and offers keyboard split and layering functions.

#CAWK3800  
**\$399<sup>99</sup>**

- 76 touch-sensitive keys
- 620 GM presets
- 400 digital effects
- Battery or AC power
- 6-track, 5-song sequencer, 16-part multi-timbral
- SD card storage slot
- 274 user-defined settings for customizing

- 182 Auto-accompaniments
- Headphone, 1/4" Pedal, USB I/O connectors

**YAMAHA**  
**YPG-625**

The YPG-625 is a handsome, partially wood-grained portable 88-note keyboard with Graded Hammer Action and 32-voice polyphony, a built-in 12-watt stereo amplifier, dual 2-way bass-ported stereo speakers. The keyboard offers a large library of sampled AWM sounds, including a realistic stereo-sampled Grand Piano, particularly enjoyable with the high-quality keyboard. The unit is also stocked with a built-in sequencer and digital effects, and the Yamaha Education Suite tutorials.

- 88 Graded Hammer-Action keys with Touch Response
- 150 auto-accompaniment styles, 30 preset songs
- 500+ GM- and XGLite-compatible voices
- Yamaha Education Suite personal tutorials
- USB/MIDI I/O, Headphone out

- Chord Dictionary displays notes and chord names
- Built-in DSP effects

- Pitch-bend wheel
- Matching wooden keyboard stand

#YAYPG625  
**\$749<sup>95</sup>**

**YAMAHA****PSR-E213**

The PSR-E213 is a highly portable keyboard with 61 full-sized keys and 32-voice polyphony. Packed with realistic AWM Tone Generation and XGLite voices, the unit also has a built-in reverb, built-in stereo amplification and speakers, a headphone output and an LCD screen. Ultra-compact and lightweight, the unit will operate off of 6 AA batteries as well, ensuring easy travel and storage.

#YAPSR213  
**\$99<sup>99</sup>**

- 362 realistic AWM and XGLite sounds
- 12 drum kits, 100 accompaniment styles

- 9 reverb effects
- Yamaha Education Suite 5 with 3 lessons, 102 songs

- Sustain pedal input
- Built-in metronome
- MIDI input and output
- AC- and battery-powered



## CASIO CTK 900

#CACTK900  
**\$179<sup>95</sup>**

The CTK-900 is a lightweight portable arranger keyboard with 61 touch-sensitive keys and 32-voice polyphony. The unit features a large 600-tone library of Casio's Zpi technology sounds, Rhythm, and One-touch auto-accompaniment presets, digital effects, built-in bass-reflex speakers with 6-watt stereo amplification, a 6-track sequencer, and a large, back-lit LCD screen. The unit serves nicely for personal practice or family fun.

- 61 touch-sensitive keys
- 176 One-touch auto-accompaniment presets
- 32 Drawbar registration setups
- 242 digital effects
- 4MB flash ROM
- Headphone, 1/4" Pedal, MIDI I/O connectors
- D-cell battery or AC power
- 6-track, 5-song sequencer, 6-part multitimbral
- 600 Zpi PCM sample tones



## CASIO CTK-810

#CACTK810  
**\$139<sup>95</sup>**

The CTK-810 is a 61-key portable keyboard for beginners, with 32-voice polyphony and touch-sensitive keys. The unit is stocked with over 500 tones, stereo speakers, and dual 2.5W amplifiers, 100-plus accompaniment rhythms with adjustable tempo, and runs on AC power or 6 AA batteries. The CTK-810 is a bargain, and a great way to get the little ones involved with music.

- 61 touch-sensitive keys
- 515 tones
- 120 rhythm pattern presets
- 4 reverbs, 4 chorus effects
- 100 songs with 2-song record/playback
- 32 Drawbar registration setups
- Headphone, 1/4" Pedal, USB connectors
- Built-in metronome
- AA battery or AC power

## YAMAHA PSR-E403

#YAPSR403  
**\$199<sup>99</sup>**

The PSR-E403 is a portable 61-note keyboard with touch-sensitivity and 32-voice polyphony, offering AC- or battery-powered operation, built-in stereo speakers and amplification, and a large selection of high-quality GM and XG-Lite sounds and Auto-Accompaniment Styles. The keyboard itself features split mode with tuning and transpose functions. This inexpensive, feature-packed keyboard is a worthy alternative for beginning students and hobbyists.

- 61 touch-sensitive keys
- 100 auto-accompaniment style presets
- 13 effects, 26 harmony types, 50 arpeggios
- Sampled stereo Portable Grand piano Sound
- Chord Dictionary and lessons
- Includes Survival Kit 1B with power supply, headphones, footswitch, and CD-ROM



- 504 GM panel voices
- Back-lit LCD
- Headphone, 1/4" Pedal, USB connectors



## CASIO LK-100

#CALK100  
**\$129<sup>99</sup>**

The LK-100 is a 61-key portable keyboard with standard-sized keys and 12-voice polyphony. The unit comes with 100 sounds and 50 rhythms, 100 songs, Bass and Chord auto-accompaniment, and a 3-step lesson system backed by a large graphic LCD screen. The unit's lighted-key feature enables the beginner to track the notes on the keyboard while playing along.

- 61 standard-size keys with lighted-key tracking feature
- Bass and Chord part auto-accompaniment
- 100 voices
- 50 rhythms
- Three-Step Lesson system for learning built-in song parts
- Headphone, MIDI, Microphone input connectors
- Back-lit LCD, AC and battery power

## CASIO SA-75

#CASA75  
**\$49<sup>95</sup>**

The SA-75 is an ultra-lightweight 37-key portable keyboard with 4-voice polyphony and a surprisingly large LCD screen. The unit comes with 100 PCM sample-based tones, 10 preset songs and 30 preset patterns, built-in stereo speakers, and a 1-watt stereo amplifier. The keyboard includes a headset microphone, and operates off of 5 AA batteries.

- 37 mini- keys
- LCD, AA battery power
- 30 preset rhythm patterns
- Headset microphone included
- 1/8" Microphone input
- 100 PCM tones
- 10 preset songs with Melody-Off control button for sing- or play-along



**Roland Expansion Options**

When first introduced, the original SR line of Roland expansion boards offered a great way to expand the sonic possibilities of your card compatible synth easily. Now Roland has done it again with the new SRX line of sound expansion boards that not only add depth to your sound palette but breathe new life into your Roland SRX compatible keyboard or rack module. From symphonic to dance there is sure to be something available to suit almost every taste. The latest addition to the ever-expanding library is Classic EP's, which promises to deliver Roland's most detailed and playable collection of electric pianos to date.



**SRX Sound Expansion Boards**

<b>SRX-01</b> Dynamic Drum Kits #ROSRX01.....	<b>\$253.50</b>	<b>SRX-07</b> Ultimate Keys #ROSRX07.....	<b>\$253.50</b>
<b>SRX-02</b> Concert Piano #ROSRX02.....	<b>\$253.50</b>	<b>SRX-08</b> Platinum Trax #ROSRX08.....	<b>\$253.50</b>
<b>SRX-03</b> Studio SRX #ROSRX03.....	<b>\$253.50</b>	<b>SRX-09</b> World Collection #ROSRX09.....	<b>\$253.50</b>
<b>SRX-04</b> Symphonique Strings #ROSRX04.....	<b>\$253.50</b>	<b>SRX-10</b> Big Brass Ensemble #ROSRX10.....	<b>\$253.50</b>
<b>SRX-05</b> Supreme Dance #ROSRX05.....	<b>\$249.95</b>	<b>SRX-11</b> Complete Piano #ROSRX11.....	<b>\$253.50</b>
<b>SRX-06</b> Complete Orchestra #ROSRX06.....	<b>\$253.50</b>	<b>SRX-12</b> Classic EPs #ROSRX12.....	<b>\$249.95</b>

**General Expansion Options**

<b>Roland M-512E</b> memory card for many Roland instruments #ROM512G.....	<b>\$96.95</b>
--	----------------

**Yamaha Expansion Options**

Yamaha's Modular Synthesis Plug-in System adds a complete synthesizer or sound-processing engine to any Modular-Synthesis Plug-in-compatible synthesizer. The PLG series not only gives you new sounds but also new synthesis architectures, new effects processors, extra polyphony, and more. It's like placing an additional synthesizer or digital effects processor inside your existing keyboard, but at a fraction of the cost. Once a plug-in board is installed, you can access any of its voices directly and edit them from the front panel of the host synthesizer. You can also use a PC-based software editor (bundled with each plug-in board) to edit any of the voices in detail.

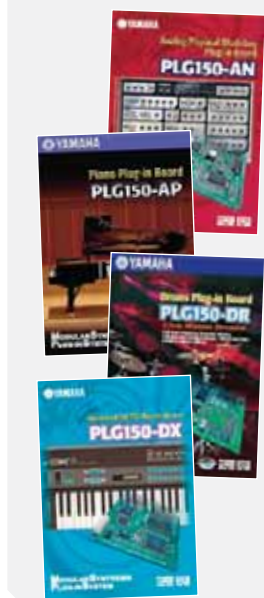

**PLG Sound Expansion Options**

<b>PLG-150-AN</b> Analog Physical Modeling expansion board #YAPLG150AN.....	<b>\$229.95</b>
<b>PLG-150-AP</b> Acoustic Piano plug-in board #YAPLG150AP.....	<b>\$269.95</b>
<b>PLG-150-DR</b> Drums plug-in board #YAPLG150DR.....	<b>\$199.95</b>
<b>PLG-150-DX</b> Advanced DX/TX plug-in board #YAPLG150DX.....	<b>\$269.95</b>
<b>PLG-150-PC</b> Percussion plug-in board #YAPLG150PC.....	<b>\$199.95</b>
<b>PLG-150-PF</b> Piano plug-in board #YAPLG150PF.....	<b>\$269.95</b>
<b>PLG-150-VH</b> Vocal Harmony plug-in board #YAPLG150VH.....	<b>\$139.95</b>
<b>PLG-150-VL</b> Virtual Acoustic plug-in board #YAPLG150VL.....	<b>\$149.95</b>
<b>PLG-150-XG</b> XG plug-in board #YAPLG150XG.....	<b>\$185.95</b>

**General Expansion Options**

<b>AIEB2</b> analog and digital I/O expansion card #YAAIEB2.....	<b>\$209.95</b>
<b>mLAN16E</b> mLAN networking expansion card #YAMLAN16E.....	<b>\$309.95</b>

**Korg Expansion Options**

Korg offers a wide variety of expansion boards to enhance the capabilities of its already powerful synthesizer line. After installing these expansion options you will surely be able to take your creativity to the next level. The MOSS board, for example, adds 6 voices of Korg's Multi-Oscillator Synthesis System from their legendary Z1 synthesizer. Prized for its unique sound and impressive physical modeling flexibility, the MOSS expansion is easily installed and adds 13 oscillator algorithms and 128 new programs. Other expansion boards in the library include the Concert Grand Piano and Future Loop Construction, adding sounds that will enhance both your studio and stage performance.



**EXB Sound Expansion Options**

<b>EXB-PCM01</b> Pianos/Classic Keys expansion #KOEXBPCM01.....	<b>\$50.00</b>
<b>EXB-PCM04</b> Dance Extreme expansion #KOEXBPCM04.....	<b>\$50.00</b>

**EXB Expansion Options**

<b>EXB-SMPL</b> TR and Triton Le Sampling Upgrade #KOEXBSMPL.....	<b>\$199.00</b>
<b>EXBDUALMP3</b> Dual MP3 Encoder/Decoder for Pa800 #KOEXBDUALMP3.....	<b>\$239.00</b>





**ROLAND**

**SA-300**

#ROSA300  
**\$1195<sup>00</sup>**

The versatile SA-300 is built to handle any type of audio source you plug into it: keyboards, microphones, rhythm machines, and CD players. The SA-300 is powered by an internal 350W amplifier, which drives a pair of high-performance 6.5-inch speakers; a 200W amp drives the 12-inch woofer unit for booming bottom-end support. With full-range, high-quality stereo 2.1 channel sound, sturdy construction, built-in effects, advanced anti-feedback control, two-piece transportability, loads of I/O options, and more, it is a traveling musician's dream.



- Four-channel sound system with mic inputs
- Wide Switch for big stereo effect, plus 3-band EQ
- Lightweight and easy to carry yet powerful
- Low Boost switch for powerful low-end
- Detachable woofer unit for easy transport

**BEHRINGER**

**Ultratone K3000FX**

#BEK3000FX  
**\$299<sup>99</sup>**



The Ultratone K3000FX is a 4-channel, keyboard/PA amplifier featuring an internal 24-bit digital FX processor and Behringer's FBQ Feedback Detection System. It is equipped with four stereo line inputs with effects sends, an XLR microphone input on channel one and an onboard 7-band graphic EQ.

- 4-channel, keyboard/PA amplifier
- (4) stereo line inputs with XLR Mic input on channel 1
- (2) XLR L/R line outputs
- 15" BUGERA woofer and a custom-made 1" tweeter
- 24-bit digital FX processor with 100 presets
- Onboard 7-band graphic EQ
- FBQ Feedback Detection System

- K1800FX** 180-watt version # BEK1800FX.....**\$249.99**
- K900FX** 3-channel, 90-watt version # BEK900FX.....**\$199.99**
- K450FX** 3-channel, 45-watt version # BEK450FX.....**\$149.99**

**ROLAND**

**CUBE Street**

#ROCUBEST  
**\$299<sup>00</sup>**

The CUBE Street is a lightweight AC- or "AA" battery-powered portable stereo amplifier and P.A. system. This potent little unit sports a pair of 2.5-watt digital stereo amplifiers featuring Roland's proprietary COSM modeling technology, effectively delivering 8 different amp sounds. The amp is also equipped with punchy Neodymium speakers, a chromatic tuner, and dedicated built-in delay and reverb effects for the mic/line and instrument channels.



- Portable stereo amplifier/P.A. for musicians and impromptu lectures/performances
- Dual 2.5-watt digital stereo amplification with 8 COSM amp sound models
- Dedicated front panel vocal and instrument volume, EQ and effects controls
- 1/4" Hi-Z instrument in, XLR, 1/4" TRS mic and line inputs
- 15-hr. battery life on 6 "AA" batteries

**ROLAND**

**KC-550**

#ROKC550  
**\$595<sup>00</sup>**

The Roland KC-550 is a 4-channel, 180-watt mixing keyboard amplifier with a 15" speaker and a horn tweeter. It is equipped with four input channels, an Output Select switch for selecting the monitor sound destination, a Shape switch for quick sound adjustment, and an XLR line output for direct connection to a mixing console.



- 180-watt keyboard amplifier with 15" speaker & horn tweeter
- Output select switch, Stereo Link In/Out
- 3-band EQ & Shape switch
- Subwoofer output (compatible with KCW-1)
- XLR line output for connection to mixing consoles

- KC-350** 120-watt version with 12" woofer  
#ROKC350 .....**\$495.00**
- KC-150** 65-watt version with 12" woofer  
#ROKC150 .....**\$345.00**
- KC-60** 40-watt version with 10" woofer  
#ROKC60 .....**\$245.00**
- KCW-1** 200-watt subwoofer for use w/KC-series amps  
#ROKCW1 .....**\$445.00**

**ALESIS**

**SUMO 300**

#ALSUMO300  
**\$349<sup>00</sup>**

The SUMO 300 is a 300-watt, 3-channel keyboard amplifier designed for both stage & studio applications. It features four stereo line inputs with post-fader effects sends, a 28-bit stereo effects processor, and an XLR microphone input on channel 1. This full range, 2-way speaker system is equipped with a 15" woofer and a horn, and has a built-in handle and wheels for easy transport.



- 300-watt, 4-channel keyboard amplifier
- 2-way speaker design, with a 15-inch woofer and a horn
- (4) stereo line inputs with post-fader effects sends
- (2) XLR L/R & 1/4" stereo headphone outputs
- Built-in 28-bit effects processor
- Master 3-band equalization section
- Weight: 75 lbs
- Dimensions: 19" x 16.5" x 29" (W x L x D)

**GRACE DESIGN**

**m906**

#GRM906  
**\$5595<sup>00</sup>**

The m906 is a high fidelity 5.1 monitor controller designed for professional surround playback applications. This 2U rack unit offers a full compliment of balanced & unbalanced analog 5.1 & digital 5.1 and stereo inputs (featuring reference quality 24/192 DAC technology). The m906s I/O is routed to the 2U rack mount mainframe, and all controls are built into an elegant, convenient desktop remote control unit.

- Multiple 5.1 and stereo analog inputs
- 24-bit/192kHz digital 5.1 & stereo inputs: AES3, S/PDIF, ADAT & TOSLINK
- Desktop remote control
- "s-Lock" phase lock loop sample clock regeneration
- Optional Downmix module & AES loophrough feature



**GRACE DESIGN**

**m904/m904b**

The m904 is a high fidelity stereo monitor controller designed for any type of audio production facility; from project studio to world class mastering facility. This unit offers a full compliment of balanced & unbalanced stereo analog and digital inputs including: AES3, S/PDIF, ADAT and TOSLINK. It is configured as a 2U rack chassis (with all system controls built into the unit), and is also available as the m904b, which consists of 2U rack chassis & a separate remote control unit.

- Multiple stereo analog inputs
- 24-bit/192kHz digital stereo inputs: AES3, S/PDIF, ADAT & TOSLINK
- Multiple speaker set selection
- "s-Lock" phase lock loop sample clock regeneration
- Available as rack only unit or rack/remote control configuration

**m904** rack only unit #GRM904 .....**\$2795.00**

**m904b** rack unit with remote control #GRM904B.....**\$2245.00**

**AUDIENT**

**ASP510**

#AUASP510  
**\$3000<sup>00</sup>**

The ASP510 system provides comprehensive control of monitoring and recording functions for multiple surround sound formats. It consists of a single-space rack unit that connects between the DAW and the speaker system through DSUB connectors, and a remote control that connects through RJ11. The remote allows you to solo and mute each speaker, and toggle between three 5.1 Surround and three Stereo sources.

- Internal Pink Noise generator for calibration
- Supports 5.1, LCRS, Dolby Surround, DVD-Video, DVD-Audio, DTS, and SACD
- Switchable ENCODER/DECODER insertion



- 6 speaker outputs, each with level trim
- Ideal for post film and video, video game production, DVD and DTS authoring



**PRESONUS**

**Central Station**

#PRCSY  
**\$499<sup>95</sup>**

The Central Station is a high-quality rack-mounted studio-monitoring interface for the modern digital studio. Featuring both analog and digital inputs, multiple monitor outputs, two headphone outputs and a purely passive signal path, the ultra-quiet Central Station can also be operated remotely via the optional CRS-1.

- (2) stereo 1/4" TRS, 1-stereo RCA, and stereo S/PDIF and TOSLINK inputs
- Talkback microphone with volume to feed Headphone/Cue output
- (3) stereo 1/4" TRS Speaker outputs, stereo Main and Cue 1/4" Line outputs
- Accurate 30-segment LED metering
- (2) front panel headphone jacks with separate volume controls

**CRS1** optional remote control w/cable #PRCSR1 .....**\$149.95**

**BLUE SKY**

**BMC MKII**

#BLBMC  
**\$695<sup>00</sup>**

The BMC (bass management controller) MKII filters and routes low frequencies to the subwoofer in surround sound production. Its single-spaced rack module connects to your DAW surround satellites and sub, and its RJ11 connected remote allows you to solo or mute and control the level of different monitors in your set-up. It can also be expanded to control larger surround sound systems.

- 80 Hz 2nd order Linkwitz-Riley high-pass filter
- 80 Hz 4th order Linkwitz-Riley low-pass filter
- Toroidal transformer for low-noise operation
- Bass management functionality defeatable for reference
- Balanced XLR I/O
- 25 foot, 6 conductor RJ11 cable included



**MACKIE**  
**Big Knob**

#MABK  
**\$299<sup>99</sup>**

The Big Knob is a powerful tabletop master level control/monitor switcher/source selector and talkback box designed for today's computer-based studios. Providing a big convenient volume knob and a flexible analog routing section, this control center offers a convenient, familiar alternative to mouse-driven volume control and monitoring.

- Balanced/Unbalanced Inputs and Outputs on 1/4" TRS connectors
- Switch between 3 sets of studio monitors
- Built-in talk microphone for communication with musicians
- Monitor 4 independent Stereo inputs including DAW mix input
- Dual headphone outputs with independent volume controls/mix bus



- Phono preamp for direct turntable connection
- Switching power supply



**PRESONUS**  
**Monitor Station**

#PRMS  
**\$299<sup>95</sup>**

The Monitor Station takes care of all your studio monitoring and communications needs from on feature packed box. The speaker output section allows you to switch between three sets of speakers so you can take the guessing out of how your mixes will sound on different types of speakers for real-world translation. Any of the three stereo inputs can be routed to the main or cue signal path as well as to each of the four headphone amplifiers for total working flexibility.

- Main speaker volume control with dim and mono switches
- (3) stereo inputs and (3) sets of balanced TRS speaker outputs
- Internal talkback mic and external XLR talkback mic input
- Accurate dual 8-segment LED metering
- (4) high-output headphone amplifiers

**BEHRINGER**  
**MINIMON MON800**

#BEMON800  
**\$39<sup>99</sup>**

The MON800 is an ultra-compact stereo monitor matrix mixer with a built-in talkback microphone. It features a dedicated input section with 4 selectable stereo inputs, 6-digit LED main stereo output meters & 3 selectable stereo speaker outputs (with separate level controls & Mute, Dim, and Mono functions). A talkback section with internal microphone and comprehensive routing options is also included.



- (4) selectable and mixable stereo inputs
- (3) selectable stereo speaker outputs
- Mute, Dim, and Mono functions
- 6-digit LED meters
- Internal talkback microphone
- High-quality potentiometers & illuminated switches



**SAMSON**  
**C-Control**

#SACCZ  
**\$99<sup>00</sup>**

The C-Control is an economical control room matrix designed for studios with multiple monitors, headphone mixes, and tape or digital sources. It provides three sets of stereo ins and outs with dubbing capability to three outputs, and allows users to select from three pairs of speakers with dim and mute. Eliminating the need for a traditional console for monitoring and routing, the C-Control master control section makes a great choice for digital audio workstations and project studios.

- Front panel talk-back mic with push to talk and slate to tape
- 6-segment LED meter
- Built-in headphone amp with level control
- MONO referencing switch

**ROLLS**  
**SLC19**

#ROSLC19  
**\$59<sup>95</sup>**

The SLC19 is a basic in-line unit designed to control stereo audio signal levels. It is a passive device, and can go anywhere in a line level signal path. The SLC19 is equipped with two 1/4" TRS & XLR inputs, and two 1/4" TRS & XLR outputs. Applications include: outputs of keyboards, microphones, mixers to powered speakers, and computers to desktop speakers.

- Compact stereo level controller
- Live, studio & broadcast applications
- (2) 1/4" TRS & XLR inputs
- (2) 1/4" TRS & XLR outputs
- Volume knob & Mute switch
- Passes Phantom Power





**GRACE**  
**m902**

#GRM902  
**\$1595<sup>00</sup>**

The m902 is a reference headphone amplifier with a full compliment of analog and digital inputs including: AES3, S/PDIF, TOSLINK, and USB. It features a high resolution 24-bit/192kHz DAC with "s-Lock" phase lock loop sample clock regeneration for ultra-low jitter and rock solid digital stability. The m902s high-current headphone amplifier circuitry is built to drive low impedance headphones effortlessly.

- (2) XLR analog inputs
- (2) front panel stereo 1/4" headphone outputs
- AES3, S/PDIF, TOSLINK, and USB digital inputs
- Dual RCA inputs & outputs
- Inputs selectable via a front panel rotary switch
- Rotary level control/edit encoder
- Large, blue 7-segment display
- Optional remote control



**Remote Control unit for m902**  
#GRRCUM902 ..... **\$115.00**



**RANE**  
**HC 6**

#RAHC6  
**\$419<sup>00</sup>**

- Master inputs are automatic balanced/unbalanced inputs
- (6) stereo amps with both master and individual level control
- Drives 32-600 ohms headphones from both front and rear panel output jacks

- Stereo/Mono switch allows both left and right headphones to be driven from a mono master input
- Signal-Present LED's on each channel
- Internal jumpers convert stereo unbalanced inputs to mono balanced inputs

The HC 6 is an extremely versatile six-channel one-rack unit headphone amplifier, ideal for both installation and studio applications. Each channel has two headphone outputs and can be driven from a master stereo input or individual channel inputs, and can be configured for mono/ balanced input using internal jumpers.

**FURMAN**  
**HA-6AB**

#FUHA6AB  
**\$369<sup>00</sup>**

The HA-6AB is a unique combination of a premium headphone amplifier and a conventional power amp. Consisting of a 20-watt per channel stereo amp and six headphone outputs, the HA-6AB provides both a high-power headphone amp solution and the capacity to power a set of small reference monitors.



- Balanced XLR and unbalanced 1/4" TS inputs
- (6) 1/4" stereo headphone outputs with individual volume controls
- Automatically switches to mono mode when right channel is not used
- Overload and signal present LED's for each channel
- Switches for two sets of speakers
- Optional HR-2 headphone remote station



**SYMETRIX**  
**304**

#SY304  
**\$299<sup>00</sup>**

- Drives headphones of any impedance
- Individual volume controls for each output
- (2) 1/4" TRS inputs
- Stereo/Mono switch
- (4) 1/4" headphone outputs, (2) 1/4" pass thru
- Compact 1/2 rack chassis
- Includes external power supply

The 304 is a high-quality four-channel headphone designed for broadcast, installed sound, podcasting, and recording applications. This compact half rack unit's output amplifier drives headphones of any impedance and provides a 6dB volume increase over most competing units. The front panel provides individual volume controls for each output, a master input volume, and a stereo/mono switch.

**ROLLS**  
**RA62C**

#RORA62C  
**\$159<sup>95</sup>**

The RA62C is a 6-channel rackmount headphone amplifier for studio or live sound applications. The rear panel stereo insert jacks on the unit allow for the monitoring of 6 separate mix feeds from the console. Each channel is equipped with a dedicated volume control, along with front and rear input jacks.



- 6-channel rack mount headphone amplifier
- Individual channel volume controls
- Individual monitoring of 6 separate mixes
- Pan and balance control
- (6) 1/4" and (6) 1/8" stereo outputs
- Stereo/Mono switch and Pan control for mixing two mono channels

**ART**  
**406**

#AR406  
**\$129<sup>00</sup>**

The ART 406 is a six-channel headphone amplifier ideal for professional, project, and home studio applications. It features individual volume control for each output, pan controls, and an insert jack for each channel (to isolate it for specific input signals). The 406 provides a front panel 1/4" stereo input, dual rear panel 1/4" inputs & Auxilliary 1/4" inputs and individual stereo 1/4" headphone outputs for each channel.



- 6-channel rack mount headphone amplifier
- Front panel 1/4" stereo input
- Dual rear panel 1/4" inputs & Auxilliary 1/4" inputs
- Insert jacks on each channel
- Volume and pan controls per channel
- Mono/Stereo push button
- 1U rack mount chassis



**BEHRINGER**  
**HA4700**

#BEHA4700  
**\$109<sup>99</sup>**

The HA4700 is a professional, four-channel headphone amplifier system for stage and studio applications. Built with quality components and loaded with pro features like: individual EQ, balance, muting, and stereo/mono monitoring per channel, the reasonably priced HA4700 is a great value and is built ruggedly for long life and durability.

**HA-8000** 8 channel version #BEHA8000 ..... **\$139.95**

- Ultra-musical high and low EQ per channel
- One front panel and two rear panel 1/4" stereo outputs on each channel
- Output level control with accurate 8-digit LED meter per channel
- Left and right mute switches allow two different mixes in Mono mode
- Paralleled main outputs allow cascading of several headphone amplifiers
- High-quality ALPS potentiometers and illuminated switches

**SAMSON**  
**C-Que8**

#SACQ8  
**\$99<sup>00</sup>**

The C-Que8 is a compact four-channel headphone amplifier featuring independent volume controls, EQ shape circuit and 6-segment LED output indicators on each channel. Ideal for digital-audio workstations, stage and studio, the C-Que8 provides dual headphone outputs—one rear and one front panel output per channel (allowing a total of eight headphones connected at the same time).



- Compact four-channel headphone amplifier
- Dual rear panel 1/4" line inputs & outputs
- EQ shape circuit per channel
- 6-segment LED level meters per channel
- Half rack chassis
- Includes tilting feet for improved positioning



**ROLLS**  
**RA53b**

#RORA53B  
**\$93<sup>95</sup>**

The RA53b is a five-channel headphone/earphone distribution amplifier with a variety of input options. Each channel has a Level control, a stereo 1/4" output jack, and a 1/8" (3.5mm) output jack. This half-rack unit provides plenty of gain for operation in noisy environments, and works with most any headphone impedance.

- Versatile 5-channel headphone amplifier
- (5) 1/4" & (5) 1/8" TRS headphone outputs with level control
- Stereo XLR, 1/4", and RCA Inputs
- Inserts on three Channels
- "Join" jack for connecting two units together
- Half rack chassis
- Includes external power supply

**SAMSON**  
**S-amp**

#SASAMP  
**\$49<sup>00</sup>**

The S-amp is a low-cost, portable 4-channel headphone amp ideal for project studio or in-the-field laptop recording applications. Designed to support a wide variety of headphone impedances, the S-amp is simple to use and ultra-lightweight, weighing only 16.5oz.

- (1) 1/4" TRS Input
- (4) 1/4" TRS Outputs
- Separate volume controls for each output
- Frequency response: 10Hz-30kHz +/-3dB
- Includes 18V AC power supply



**BEYERDYNAMIC****DT770 M**

Beyerdynamic DT770 M's are wide-range closed-back circumaural headphones designed for low impedance operation (without compromising audio quality, adding amplifiers or transformer connections).

- Excellent noise isolation
- Bass-reflex design provides powerful bass reproduction
- Very soft viscose earcups for comfort
- Stereo 1/4" and 1/8" mini connections
- 80-ohms nominal impedance
- 5Hz-30kHz frequency response



#BEDT770M  
**\$209<sup>95</sup>**

**REMOTE AUDIO****HN-7506**

The Remote Audio HN-7506 are closed-back circumaural headphones specifically designed for high-quality monitoring in high-noise environments.

- 40mm Neodymium driver (from the popular Sony7506's)
- Superior isolation w/ over 40dB of attenuation
- Large, Oil-filled cup design reduces pressure and fatigue
- 1/4" stereo and 1/8" mini connections
- 10Hz-20kHz frequency response



#REHN7506  
**\$285<sup>00</sup>**

**SENNHEISER****HD25-1 II**

Popular among professional engineers and audio recordists, the Sennheiser HD25-1 II supra-aural closed-back stereo headphones are extremely comfortable and durably constructed.



- Closed-back, supra-aural design
- Adjustable split headband for exceptional comfort
- 1/4" and 1/8" mini connections
- 85-ohms nominal impedance
- 30Hz-16kHz frequency response

#SEHD251II  
**\$199<sup>99</sup>**

**SONY****MDR-7509 HD**

The Sony MDR-7509 HD circumaural closed-back dynamic headphones provide clear, high-quality sound reproduction with a very high output and superior bass response.



- Unique foldable design
- Circumaural, closed-back dynamic design
- Single-sided coiled cable with stereo 1/4" and 1/8" mini connections
- 24-ohms nominal impedance
- 5Hz-30kHz frequency response

#SOMDR7509HD  
**\$219<sup>00</sup>**

**AKG****K271S**

AKG K271S closed-back circumaural studio headphones provide smooth, clean sound reproduction, maximum isolation, and neutral, flat response.

- Closed-back, circumaural design
- Detachable single-sided cable with stereo 1/4" and 1/8" mini connections
- Headband mute switching
- 55-ohms nominal impedance
- 16Hz-28kHz frequency response



#AKK271S  
**\$199<sup>00</sup>**

**BEYERDYNAMIC****DT770 PRO**

Beyerdynamic DT770's are professional, extremely wide-range, closed-back circumaural headphones with a bass-reflex system design, and comfortable ear-cups.

- Excellent noise isolation
- Rugged construction with replaceable parts
- Very soft viscose earcups for comfort
- 1/4" stereo and 1/8" mini connections
- 5Hz-35kHz frequency response



#BEDT770PRO  
**\$183<sup>50</sup>**

**BEYERDYNAMIC****DT150**

The Beyerdynamic DT 150's are closed-back circumaural dynamic headphones designed for broadcast, film, and recording studio applications.



- Closed-back circumaural headphone
- Full modular construction for easy servicing
- Detachable tinsel-conductor cable with retaining screw
- 1/4" stereo connection
- 250-ohms nominal impedance
- 10Hz-30kHz frequency response

#BEDT150  
**\$169<sup>95</sup>**

**BEYERDYNAMIC****DT250 250**

Beyerdynamic DT250250's are closed-back circumaural headphones designed for critical listening applications in professional broadcast and music recording studios.



- Closed-back circumaural design
- Neodymium magnet driver system
- 250-ohms nominal impedance
- Coiled cable with gold-plated mini stereo plug and 1/4" adapter
- 250-ohms nominal impedance
- 10Hz-30kHz frequency response

#BEDT250250  
**\$219<sup>00</sup>**



**BEYERDYNAMIC****DT250 80**#BEDT25080  
**\$154.95**

Beyerdynamic DT25080's are closed-back circumaural dynamic stereo headphones ideally suited for audio monitoring in broadcast facilities and recording studios.

- Closed-back circumaural design
- Neodymium magnet driver system
- 80-ohms nominal impedance
- Coiled Cable with Gold Plated Mini stereo plug and 1/4" adapter
- 80-ohms nominal impedance
- 10Hz-30kHz frequency response

**SONY****MDR-7506**#SOMDR7506  
**\$99.00**

The industry standard Sony MDR7506's are great sounding stereo headphones featuring a closed-back circumaural design, superior sensitivity, and exceptional dynamic response.

- 40mm Neodymium driver
- Compact, foldable design
- Coiled cable with gold-plated plug with both 1/4" stereo and 1/8" mini connectors
- 10Hz-20kHz frequency response

**SENNHEISER****HD25 SP**#SEHD25SP  
**\$129.00**

Lightweight and accurate, Sennheiser HD25's are closed supra-aural headphones with a compact design and highly efficient neodymium drivers.



- Closed-back supra-aural design
- Convenient flat-folding earcups
- Tough, detachable stranded steel cable • 1/4" stereo and 1/8" mini connections
- 30Hz-16kHz frequency response

**SENNHEISER****HD280 PRO**#SEHD280P  
**\$99.99**

The durable Sennheiser HD280P's are professional closed-back circumaural headphones designed to meet the needs of location recordists and broadcast engineers.



- Effectively isolates noise with up to 32dB of attenuation
- Convenient and comfortable collapsible design
- Durable build with user replaceable parts • 1/4" stereo and 1/8" mini connections • 8Hz-25kHz frequency response

**AUDIO-TECHNICA****ATH-M40FS**#AUATHM40  
**\$74.95**

ATH-M40FS's are high-quality circumaural closed-back professional studio headphones designed with an extended frequency response; particularly well suited for mixing and monitoring.

- Superb ambient noise isolation
- Single sided cable with stereo 1/4" stereo and 1/8" mini connections
- 60-ohms nominal impedance
- 5Hz-28KHz frequency response

**SONY****MDR-V600**#SOMDRV600  
**\$64.95**

Great sounding and comfortable, the Sony MDRV600's are closed-back circumaural headphones designed with both musicians and engineers in mind.

- 40mm Neodymium driver
- Reversible earcups for Single-Side Monitoring • Compact, foldable design • 1/4" stereo and 1/8" mini connectors
- 5Hz-30kHz frequency response

**AUDIO-TECHNICA****ATH-M30**#AUATHM30  
**\$59.95**

The ATH-M30 dynamic closed-back stereo headphones provide exceptional sound reproduction for audio recording and monitoring situations.



- Closed-back, circumaural design
- Neodymium magnets and copper-clad aluminum wire voice coils
- Single-sided cable with stereo 1/4" and 1/8" mini connections
- 65-ohms nominal impedance
- 20Hz-20kHz frequency response

**SENNHEISER****eH 250**#SEEH250  
**\$48.95**

The Sennheiser eH 250's are ultra-lightweight stereo headphones designed for DJ and portable listening use. They feature comfortable, leatherette earpads and extended low-end frequency response.



- Closed back supra-aural design
- Low distortion, clean, solid bass performance
- 32-ohms nominal impedance
- 14Hz-19kHz frequency response

**SONY****MDR-7502**#SOMDR7502  
**\$46<sup>50</sup>**

Smaller in size than the industry standard 7506's, the MDR7502's are affordable closed-back supra-aural stereo headphones with great sound reproduction and superior efficiency.

- 30mm Neodymium driver
- Compact design
- Gold plated 1/4" stereo and 1/8" mini connectors
- 60Hz-18kHz frequency response

**SENNHEISER****eH 150**#SEEH150  
**\$29<sup>95</sup>**

Sennheiser EH 150's are supra-aural closed-back headphones with moderate ambient noise attenuation, and a comfortable, ultra-lightweight design.

- Lightweight and ruggedly constructed; offer great portability
- 10-ft. dual-sided copper cable
- 32-ohms nominal impedance
- 18Hz-18kHz frequency response

**AUDIO-TECHNICA****ATH-M20**#AUATHM20  
**\$39<sup>95</sup>**

ATH-M20's are closed-back dynamic headphones with a circumaural design and high output 40mm Neodymium drivers, providing listeners with good sound isolation, full bass response, and extended high-end presence.

- Closed-back, circumaural design
- Single-sided cable with stereo 1/4" and 1/8" mini connections
- 40-ohms nominal impedance
- 30Hz-20kHz frequency response

**AUDIO-TECHNICA****ATH-M3X**#AUATHM3X  
**\$24<sup>95</sup>**

ATH-M3X's are circumaural closed-back dynamic stereo headphones with an extended high-frequency response and full low-frequency sound reproduction.

- Closed-back, circumaural design
- Excellent isolation and powerful bass
- Dual sided durable cable with stereo 1/4" and 1/8" mini connections
- 32-ohms nominal impedance
- 20Hz-20kHz frequency response

**AKG****K55**#AKK55  
**\$29<sup>95</sup>**

AKG K55 closed-back circumaural stereo headphones are ideal for home studio recordists and musicians in need of an attractively priced, quality personal monitoring system.

- Circumaural, closed-back dynamic design
- Lightweight and highly comfortable
- Excellent price and performance
- 32-ohms nominal impedance
- 16Hz-20kHz frequency response

**AKG****K44**#AKK44  
**\$29<sup>95</sup>**

AKG K44's are closed-back circumaural headphones designed to provide good ambient noise rejection while delivering a smooth, high-output response.

- Supra-aural, closed-back dynamic design
- Single-sided cable with stereo 1/4" and 1/8" mini connections
- 32-ohms nominal impedance
- 18Hz-20kHz frequency response

**BEYERDYNAMIC****DT 880 2005 Edition**#BEDT88005  
**\$299<sup>00</sup>**

The DT 880 2005 Edition is a set of semi-open, dynamic, circum-aural stereo headphones, featuring an extended frequency response and transparent reproduction. These ruggedly-constructed professional headphones are equally valid for critical or enjoyment listening applications.

- Adjustable headband with replaceable pad, earpads
- Bass-reflex system with extended low end
- Detachable gold-plated 1/4" stereo adapter
- 250-Ohms nominal impedance
- 5Hz-35kHz frequency response

**AKG****K240 MKII**#AKK240MKII  
**\$199<sup>00</sup>**

The AKG K240 MKII is a set of comfortable semi-open dynamic headphones for hi-fi or studio recording applications. These high-output headphones feature AKG's advanced Varimotion transducer technology with uncolored sound and an extended frequency response.

- Self-adjusting headband with leatherette and velvet earpads
- Single-sided detachable 10' straight and 16.5' coiled cables
- Detachable gold-plated 1/4" stereo adapter
- 55-Ohms nominal impedance
- 15Hz-25kHz frequency response



## AKG K240 MK II

AKG K240 MKII's are semi-open back, circumaural dynamic headphones that deliver a wide dynamic range and highly accurate sound reproduction.

- Semi-open back, circumaural design
- Acoustically tuned vented earcups
- Solid, well balanced low-frequency presence • stereo 1/4" and 1/8" mini connections
- 55-ohms nominal impedance
- 15Hz-25kHz frequency response



#AKK240MK2  
**\$199<sup>00</sup>**

## SENNHEISER HD212

Sennheiser's lightweight HD212 stereo headphones are made with DJ's and discerning listeners in mind. They offer good isolation from external sound sources while producing impressive sonic results.

- Closed-back, semi-circumaural design
- Full bass and detailed mid-range sound reproduction • Stereo 1/4" and 1/8" mini connections
- 32-ohms nominal impedance
- 12Hz-19kHz frequency response



#SEHD212  
**\$59<sup>99</sup>**

## SENNHEISER HD202

Designed for professional DJ or personal use, the Sennheiser HD202 headphones are very lightweight, closed-back headphones that offer good isolation and high SPL capability.



- Dual-sided cable with stereo 1/4" and 1/8" mini connections
- Convenient belt clip for easy adjustment of cable length
- 32-ohms nominal impedance
- 18Hz-18kHz frequency response

#SEHD202  
**\$29<sup>95</sup>**

## SENNHEISER HD600

Sennheiser HD600's are high-end, open-back headphones perfect for classical recording and other critical monitoring applications.



- High-quality, open metal mesh earpiece covers
- Lightweight aluminum voice coils
- Detachable copper cable, Kevlar-reinforced • 1/4" stereo and 1/8" mini connections
- 12Hz-39kHz frequency response

#SEHD600  
**\$299<sup>95</sup>**

## BEYERDYNAMIC DT990PRO

DT990PRO open-back circumaural stereo headphones are a popular choice among professional engineers and field recordists for their excellent sound reproduction and wide frequency response.

- Single-sided coiled cable with stereo 1/4" and 1/8" mini connections
- Soft viscose ear pads
- 250-ohms nominal impedance
- 5Hz-35kHz frequency response



#BEDT990PRO  
**\$239<sup>00</sup>**

## SENNHEISER eH 350

Equally well suited for location sound or studio audio monitoring, the Sennheiser EH 350's are open-back supra-aural headphone with excellent spatial imaging.

- Open-back supra-aural design
- Replaceable cable and leatherette ear pads
- 32-ohms nominal impedance
- 14Hz-22kHz frequency response



#SEEH350  
**\$59<sup>95</sup>**

## SAMSON RH100

The Samson RH100 circumaural open-back stereo headphones provide the ideal combination of quality and comfort for extended listening to portable digital devices such as MP3/CD/DVD players.



- Circumaural open-back dynamic design • 40mm Neodymium driver
- Single-sided cable with stereo 1/4" and 1/8" mini connections
- 64-ohms nominal impedance
- 20Hz-20kHz frequency response

#SARH100  
**\$29<sup>00</sup>**

## AUDIO-TECHNICA ATH-M2X

ATH-M2X's are supra-aural open-back stereo headphones with a wide frequency response and well-defined dynamics; especially suited for use with portable digital listening devices.



- Open-back, supra-aural dynamic design
- Dual sided durable cable with stereo 1/4" stereo and 1/8" mini connections
- 32-ohms nominal impedance
- 20Hz-20kHz frequency response

#AUATHM2X  
**\$18<sup>95</sup>**



**GENELEC****8030A**

Like all 8000 series monitors, the 80-watt bi-amplified 8030A's represent the next generation of Genelec's expertly-crafted studio monitors. Their enhanced low end and greatly improved imaging is a result of the revolutionary port design and unique rounded edge enclosure. Ideal for professional desktop recording and mixing, these compact reference monitors fit into small studio environments easily and faithfully deliver a true representation of the recorded audio.

- Iso-Pod Mounting Stand allows for vertical or horizontal positioning while isolating monitor from sympathetic vibration • 80 watts total power
- 5" Woofer/3/4" Tweeter
- Unique rounded enclosure design for improved imaging
- XLR I/O connectors
- 58Hz–20kHz frequency response • 12 lbs (each)



#GE8030A  
**\$648<sup>50</sup>** each

**GENELEC****8040A**

The 8000 series from Genelec represents the next generation of industry-standard reference monitors. Compact but powerful, the bi-amplified 8040A's deliver 180 watts of power. Their superior stereo imaging, detail, and ultra-wide frequency response are results of the carefully matched amplifiers, a unique flow optimized bass-reflex port design, and the gently curved/rounded edges of the rigid metal enclosure. The 8040A's are truly professional investments for recording studios, broadcast control rooms and mobile production suites.

- 180 watts combined power with a 6.5" woofer and 3/4" tweeter • 48–20kHz frequency response
- Flow optimized bass-reflex port provides no compression or port noises • Multiple rear panel adjustments for tuning room response • Unique Iso-Pod eliminates surface borne sound coloration
- Active electronic protection and crossover circuitry
- 18.9 lbs (each)



#GE8040A  
**\$1157<sup>50</sup>** each

**DYNAUDIO****BM6A**

Providing full-range audio reproduction, the DynAudio BM6A's are two-way, bi-amplified 200-watt near-field monitors capable of producing highly-detailed transparent audio. The precision-engineered BM6A's accurately reproduce source material with dynamic musicality and exceptional imaging, making them a professional choice for even the most demanding recording needs of commercial, project, and post-production facilities.

- Low/high-frequency and level controls
- 41Hz–21kHz frequency response
- 6 1/2" Woofer/1" Tweeter
- 200 watts total power
- Adjustable low-frequency EQ
- Female XLR input • 24 lbs (each)



#DYBM6A  
**\$1699<sup>00</sup>** pair

**DYNAUDIO****BM15A**

Providing full-range audio reproduction, the Dynaudio BM15A's are two-way, bi-amplified 300-watt near-field monitors capable of producing highly detailed transparent audio. The precision-engineered BM15A's accurately reproduce source material with dynamic musicality and exceptional imaging, making them an excellent professional choice for the most demanding recording needs of commercial, project, and post-production facilities.

- 300 watts total power with 10" woofer and 1" soft dome tweeter
- Accurate, detailed response capable of providing mid-field level sonics • Adjustable low-frequency EQ
- Low/high-frequency trim and level controls
- Female XLR input • 40Hz–22kHz frequency response
- 41 lbs (each)

#DYBM15A  
**\$2549<sup>00</sup>** pair

**GENELEC****7050B**

Delivering 70 watts of deep articulated bass, the compact 7050B is an 8", 70-watt, active multi-channel subwoofer with a unique spiral enclosure design that minimizes airflow noise and distortion. It is ideal for full-range stereo monitoring and features 5 main input channels with a separate LFE channel for professional 5.1 broadcast and audio production.

- 70 watts total power
- Patented LSE (Laminar Spiral Enclosure)
- 5 main inputs
- LFE channel for 5.1 audio production (85-120Hz)
- Active crossover and overload protection circuitry
- 25Hz–85Hz frequency response • 40 lbs



#GE7050B  
**\$1049<sup>00</sup>** pair

## JBL LSR4328P

Designed for today's professional digital production, the JBL LSR4328P's incorporate advanced technology that exactly matches the drivers and crossover network and analyzes each speaker, compensating for standing waves and proximity to boundaries. This helps create monitors that are calibrated to compensate for any room flaws, creating mixes that have superior clarity, accuracy and articulate detail. The 8" woofer and 1" neodymium tweeter are driven by 150- and 70-watt power amplifiers respectively.

- 220 watts of power combined to the 8" woofer and 1" tweeter
- Room Mode Correction combines DSP software and calibration mic for room analysis
- 24-bit/96kHz digital connectivity via AES/EBU XLR and S/PDIF RCA connectors
- LSR4300 Control Center Software provides control of system parameters via computer
- XLR and 1/4" balanced analog inputs
- 50Hz–20kHz frequency response

**LSR4326P** same as above with 6.5" woofer #JBSLR4326PP ..... **\$1039.00**

#JBLSR4328PP  
**\$1459<sup>00</sup>**  
pair



## EVENT Studio Precision 8



For the studio engineer who desires the power of midfield monitors, but has the space for near-fields, the bi-amplified Event ASN8 (Precision 8's) is the monitor for you. Selected by many top R&B, Hip-Hop, and Rock producers today, the P8's are custom-designed in every aspect. They utilize high-output, ultra-efficient neodymium drivers, a dual port design, and the sonic accuracy required to produce the subtle nuances, enhanced bass, and detailed musicality necessary for complete confidence in your mixes.

- 280 watts total power into 8" woofer and 1" tweeter
- Variable Low/High-frequency adjustments
- 80Hz high-pass filter switch
- Balanced 1/4" and XLR inputs
- Output circuit limiting
- 35Hz–20kHz frequency response
- 32 lbs (each)

#EVASPB8  
**\$649<sup>50</sup>**  
each

## EVENT TR8

The Event TR8's are precision tuned bi-amplified reference monitors that offer a flat, uncolored sound that's true for mix and recording monitoring. Two ultra-efficient custom amplifiers deliver up to 100 watts of power to the 8" low-frequency driver and 1" silk soft-dome tweeter. The TR8's are capable of producing high-output, low-distortion audio and are identically matched, improving overall stereo imaging and phase response.

- 100 watts combined power with a 8" woofer and 1" silk tweeter
- Precisely-tuned cabinet
- Balanced/Unbalanced XLR/1/4" TRS connector, unbalanced RCA input
- 35Hz–20kHz frequency response
- 24.7 lbs (each)



#EVTR8  
**\$249<sup>50</sup>**  
each

## JBL LSR6328P

The JBL LSR6328P's are exceptionally accurate, bi-amplified 370-watt studio reference monitors that combine advanced features and design for better mix position clarity, electronic control of room acoustics, and a smoother, more detailed low-frequency response, ideal for both professional recording and post-production environments.

- Advanced Linear Spatial Reference design provides flatter off-axis response for improved clarity
- RMC (Room Mode Correction) electronically controls room acoustics (optional measurement kit)
- Built-in mounting points for permanent installs
- Balanced/ Unbalanced XLR and 1/4" inputs
- 370 watts total power
- 39 lbs (each)
- 8" Woofer/1 1/2" Tweeter
- 50Hz–20kHz frequency response

#JBLSR6328P  
**\$1299<sup>00</sup>**  
each



## JBL LSR6312SP



The JBL LSR6312SP is an efficient 250-watt powered subwoofer that provides an extended low-bass frequency response and sophisticated bass management for professional stereo and multi-channel applications.

- 250 watts total power
- 12" Woofer
- Supports multiple surround formats including Dolby ProLogic, AC-3, DTS and others
- Room Mode Correction (RMC) electronically controls response peaks due to room acoustics
- Neodymium Differential Drive technology (NDD) offers advanced control of low frequencies
- Multi-channel Balanced XLR I/O
- 28Hz–80Hz frequency response
- 50 lbs

#JBLSR6312SP  
**\$1449<sup>00</sup>**

**QUESTED****S6R**

The S6R is a professional active 2-way studio monitor, delivering 110 watts of bi-amplified power and full-range frequency reproduction. The compact speaker cabinet is of a tight infinite baffle design and the high-headroom amplifiers are well-matched with the drivers for extra clarity and virtually no distortion. There is a rear-panel input sensitivity control, and an internal operating voltage adjustment allows for international use.



**\$750<sup>00</sup>**

- 110 watts total power • 16.5 lbs (each)
- 5.5" Bass Cone woofer, 1.1" soft dome tweeter
- Infinite Baffle cabinet design
- High-headroom, distortion-free amplification
- Adjustable input sensitivity
- XLR/1/4" TRS Combo connector
- 75Hz-22kHz frequency response

**QUESTED****S7R**

The S7R is a compact active 2-way professional studio monitor housed in a ported cabinet with a bass-reflex design. The bi-amplified unit outputs 190 watts of consistent, low-distortion power, with reliable LF response and a strong "sweet spot." The speaker is equipped with rear-panel HF and LF adjustable filtering, and may be internally adjusted for compliance with international operating voltages.



#QUS7R  
**\$1090<sup>00</sup>**

- 190 watts total power
- 6.5" Bass Cone woofer, 1.1" soft dome tweeter
- Bass-reflex cabinet
- High-headroom, distortion-free amplification
- Adjustable HF and LF filters and input sensitivity
- XLR/1/4" TRS Combo connector
- 65Hz-22kHz frequency response
- 25.8 lbs (each)

**GENELEC****8020A**

The 8020APM is a highly compact 2-way active monitor featuring a die-cast aluminum cabinet enclosure and realistic frequency reproduction with a well-defined low end. The unit serves up 40 watts of matched bi-amplified power, and a Directivity Control Waveguide design, allowing for consistent on- and off-axis response. The Minimum Diffraction Enclosure housing maintains distortion-free output at high volumes with reliable imaging.

- 40 watts total power • XLR I/O connectors
- 4" woofer, 3/4" metal dome tweeter
- Bass-reflex die-cast aluminum cabinet
- Iso-Pod rubber cabinet stand minimizes desk or console vibrations
- Volume, Treble, Bass, and Bass Roll-off controls
- 66Hz-20kHz frequency response • 8.1 lbs (each)



#GE8020APM  
**\$399<sup>00</sup>**

**BLUE SKY****EXO**

The EXO is an active home or desktop 2.1 monitoring system with dual compact 2-way satellites and an 8" subwoofer equipped with isolation feet, and 160 watts total power. The reflection-reducing satellite cabinets are angled for proper directivity, and the included EXO proprietary controller preamp is equipped with level and bass controls and all connectivity, including inputs for portable listening devices and a headphone output.



#BLEXO  
**\$349<sup>00</sup>**

- 160 watts total system power • 3" Neodymium mid, 1" soft dome tweeter (Satellites)
- 8" Cone woofer (Subwoofer) • Angled satellite cabinets for directivity, isolation feet for sub
- Includes EXO proprietary controller/preamp • 3 lbs (each satellite), 25 lbs (sub)
- Volume, Bass and per-channel Input Gain controls
- XLR/1/4" TRS Combo, RCA Phono and 1/8" Mini connectors
- 140Hz-20kHz frequency response (satellites), 20Hz-200Hz (sub)

**KRK****VXT6**

The VXT6 is a robust active 2-way monitor speaker for professional or project studio use. The curved and ported low-resonance cabinet has a wide "sweet spot", and houses two amplifiers totaling 90 watts of power, along with a 6" Kevlar woofer notable for high rigidity and smooth delivery. The abundantly-equipped speaker offers level and filter controls, ground-lift and auto-mute switching, voltage selection, and a clip-indicator/limiter switch.

- 90 watts total power • 111dB SPL
- 6" Kevlar woofer, 1" silk dome tweeter
- Ported, curved bass-reflex cabinet
- Frequency, limiter and ground-lift switching
- Tamper-resistant switch covers
- XLR/1/4" TRS Combo connector
- 49Hz-22kHz frequency response • 27 lbs (each)



#KRVXT6  
**\$449<sup>00</sup>**



## FOSTEX 6301BEAV

The 6301BEAV is an active desktop or rack mount monitor speaker with 10 watts of power and a 4" full-range driver, designed for mobile production and broadcast applications. The unit is made of road-worthy die-cast aluminum and sports a clear, consistent sound ideal for functional monitoring in the field or keyboard monitoring in the studio.

- 10-watts total power
- 4" full-range speaker
- Cast aluminum enclosure and grille
- 84dB SPL • Volume control
- XLR and 1/4" TS connectors
- 80Hz-13kHz frequency response
- 6.6 lbs (each)



#FO6301BEAV  
**\$179<sup>95</sup>**

## YAMAHA MSP7

The MSP7 Studio is a bi-amplified studio monitor with 130 watts total power and a ported bass-reflex cabinet. The low-distortion amplifiers are specifically matched to the appropriate drivers for a balanced, extended-range frequency delivery. The speaker is equipped with a versatile set of controls for optimizing performance in its inhabited acoustic space, and a clip indicator light is a useful feature for high-level monitoring.



#YAMSP7S  
**\$599<sup>99</sup>**

- 120 watts total power • Ported bass-reflex cabinet
- 6.5" cone woofer, 1" titanium dome tweeter
- Individually-matched LF and HF amplifiers
- Volume, Low-cut filter, High and Low trim controls
- XLR connector • 45Hz-40kHz frequency response
- 26.9 lbs (each)

## EVENT S100



The S100N is an active down-firing subwoofer designed for 2.1, Home Theater or Surround monitoring applications, with 100 watts powering and an 8" cone woofer. The unit is equipped with a rear panel input-sensitivity control, includes 4 isolating rubber feet to minimize floor vibration, and a handy mute footswitch.

- 100 watts total power
- 8" Polypropylene cone woofer
- Down-firing design • Volume control
- Muting footswitch and rubber feet included
- RCA Phono and 1/4" TS connectors
- 35Hz-120Hz frequency response
- 32 lbs

#EVS100N  
**\$299<sup>00</sup>**

## YAMAHA MSP5

The MSP5 Studio is a compact 2-way bi-amplified studio monitor with 67 watts total power, designed for smaller studio spaces and desktop audio applications. The speakers are housed in a handsome, low-resonance bass-reflex cabinet, and the Waveguide horn tweeter allows for wider uniform HF dispersion. The unit has a set of HF and LF trim switches for tailoring the speaker output to specific acoustic needs..



#YAMSP5S  
**\$249<sup>99</sup>**

- 67 watts total power • Bass-reflex cabinet
- 5" cone woofer, 1" titanium dome tweeter
- Waveguide horn tweeter for accurate HF dispersion
- High and Low trim controls, level control
- XLR connector • 50Hz-40kHz frequency response
- 17.4 lbs (each)

## TAPCO SW-10

The SW10 is a compact active studio subwoofer with dual 60-watt amplifiers with separate left/right level controls, and a 10" dual voice-coil woofer. The MDF cabinet design provides substantial internal baffling, minimizing resonance and reflection inaccuracies and optimizing LF "punch." Other niceties include adjustable sensitivity control and polarity switching, and a selectable multi-voltage power supply for international use.

- 120 watts total power
- Compact MDF enclosure with horn-loaded design
- XLR and RCA Phono connectors
- 34Hz-110Hz frequency response
- Input-sensitivity knob, polarity and multi-voltage switches
- Individual left and right crossovers and volume controls • 28 lbs



#TASW10  
**\$349<sup>99</sup>**

**BLUE SKY****Media Desk 2.1**#BLMD2.1  
**\$599<sup>00</sup>**

The Media Desk 2.1 is a professional multimedia monitoring system that features a pair of passive two-way satellite speakers and an active subwoofer. The subwoofer provides 65 watts of power to itself and 55-watts for each satellite, immediately revealing mix problems with its exceptional detail and overall tonal balance. 5.1 surround expansion is easily accomplished and is ideal for digital broadcast production, authoring DVD's, and surround mixing for games and film.

- 65 watts to the 8" subwoofer, 55 watts to each 4" satellite with 1" dome tweeters • Compact design especially suited for near-field mixing • Excellent detail with smooth, extended full-range response
- Studio quality monitoring for desktop audio production
- XLR and RCA inputs • 35Hz–20kHz frequency response

**Pro Desk 2.1** larger version of above w/100-watt subwoofer and 60-watt satellites #BLPD2.1...**\$1,195.00**

**MACKIE****HR824mk2**#MAHR824MK2  
**\$649<sup>99</sup>** each

The popular Mackie HR824mk2 is an active and THX pm3-certified studio monitor, full-range and bi-amplified with 250-watts of total output power. Clean and punchy, the speakers deliver an articulate sound with a wide sweet-spot and distinct low-bass characteristics, ideal for long fatigue-free studio session hours.

- THX pm3-approved active studio monitor with 250-watts total power • 8.75" Woofer, 1" Tweeter
- Active crossovers and dual overload-protection circuits
- Foam-filled acoustic damping for minimized coloration
- Acoustic Space controls for optimizing speakers in studio environment
- Balanced ¼" an XLR, unbalanced RCA inputs
- 39Hz-20kHz frequency response
- 34.6 lbs (each)

**ADAM****P11A**#ADP11A  
**\$999<sup>50</sup>** each

The P11A is a 300-watt professional 2-way active monitor that produces unique imaging and outstanding transient response from its 7" woofer and Advanced Folded Ribbon technology (A.R.T.) tweeter. This design produces mid-high frequencies far more efficiently than typical 1" dome tweeters, resulting in dramatically improved clarity and music reproduction; ideal for recording applications including broadcast and post production.

- 300 total watts from 7" woofer and folded ribbon tweeter
- Superior design and response of mid-high frequencies
- Dual digital amplifiers remain cool and exhibit excellent dynamic response
- Rear-panel room and EQ controls
- XLR input • 48Hz–35kHz frequency response

**ALESIS****M1 Active Mk2**#ALM1AM2  
**\$299<sup>00</sup>** pair

Featuring faithful, accurate, full-range power, the M1 Active Mk2's are bi-amplified studio monitors designed with a lightweight, custom 6.5" woofer and 1" silk tweeter capable of delivering 100 watts of total power. The wide sweet spot and detailed, flat response are results of the uniquely offset tweeters, dual front-mounted ports, and a special time-alignment circuit which provides perfect frequency synchronization of the low and high driver outputs.

- 100 watts bi-amplified power into 6.5" woofer and 1" silk tweeter • Ideal for home/project studios needing superior performance and affordability
- Custom, lightweight drivers produce a quicker, smoother response • Special time alignment circuitry and active crossover for improved imaging and accuracy
- 38Hz–23.5kHz frequency response • 19.5 lbs (each)

**ALESIS****M1 Active 620**#ALM1A620  
**\$399<sup>00</sup>** pair

The M1 Active 620's feature 100 watts of accurate full-range bi-amplified power from their 6.5" woofer and 1" silk dome tweeter. High-precision drivers and an acoustical waveguide deliver lower distortion with a smoother frequency response and superior imaging, making them ideal for home/project studios requiring better performance from an affordable monitor.

- 100 watts bi-amplified power with 6.5" woofer and 1" silk tweeter • 1" thick front baffle virtually eliminates speaker resonance • Low Frequency Density Switch for acoustic space adjustment of monitors
- Rear port design for deep bass extension and increased loudness • XLR and 1/4" TRS inputs
- 49Hz–20kHz frequency response • 21 lbs (each)



**M1 Active 520** 75-watt version with 5" woofer and .75" tweeter #ALM1A520...**\$199.00**

## KRK VXT8

The VXT8 is an active 2-way studio monitor speaker delivering full-range audio reproduction and bi-amplified, 180-watt power. The ported, low-resonance speaker cabinet is expressed in a curved, contoured design, allowing for truer imaging and a wider "sweet spot." The speakers are designed with vented formers, greatly reducing power compression artifacts and maintaining consistent punch and clarity. The VXT8 is an excellent choice for higher-end commercial or project studios.

- 180 watts total power
- 8" Kevlar woofer, 1" silk dome tweeter
- Ported, low-resonance cabinet
- Accurate imaging, widened sweet spot
- 3-way HF and LF control switches
- XLR/TRS combo connectors
- 37Hz-22kHz frequency response • 41 lbs (each)



#KRVXT8  
**\$599<sup>00</sup>**  
each

## DIGIDESIGN RM1



The RM1 is a professional 2-way nearfield studio monitor, delivering 130 watts of bi-amplified power and full-range, reference-quality frequency reproduction. Featuring Advanced Transmission Line technology, the monitor plays back with consistent frequency response, even at bone-crushing levels. The wide-dispersion cabinet is equipped with a DSP crossover and a bass port emulation mode, along with adjustable gain, HF and LF output, and speaker placement settings for optimized studio performance.

- 130 watts total power • 5.5" cone woofer, 1" soft dome tweeter
- 48-bit DSP engine with digital crossover
- Bass Port emulation adds ported cabinet-like bass coloration
- HF and LF controls, channel assign, gain trim
- XLR analog, XLR AES digital, RJ45 connectors
- 50Hz-25kHz frequency response • 14 lbs (each)

#DIRM1  
**\$1249<sup>00</sup>**  
each

## TAPCO S5

The Tapco S5's (by Mackie) are compact, affordable bi-amplified near-field monitors capable of producing large-scale sound with up to 120 watts of power. Driven by a 5" driver and 1" tweeter, the S5's combine a musical, well-balanced tone and imaging. The cabinet is quite solidly constructed for a speaker of this size and offers users a variety of rear panel adjustments for fine-tuning room response. Ideal for producing high-quality mixes in restricted spaces, the S5's are great first speakers for home studios, home theater, and control-room use.

- 120 watts combined power with a 5" polypropylene woofer and 1" silk dome tweeter
- Dual high-precision amplifiers deliver 60 watts
- Waveguide loaded response allows for extended fatigue-free session
- Low/high-frequency boost adjustments
- Balanced XLR/TRS and unbalanced RCA inputs
- 64Hz-20kHz frequency response • 17 lbs (each)



#TAS5  
**\$299<sup>99</sup>**  
pair

## TANNOY Reveal 6

Improving upon the recording industry success of the original Reveal's, the precision-engineered Reveal 6 passive reference monitors utilize Klippell-based symmetry analysis, an advanced measurement and distortion analysis technology that produces one of the most rigid cabinets available. The result is a monitor that handles up to 100 watts of total power with significantly reduced distortion, a punchy controlled bass response, and an open, detailed response with outstanding vocal intelligibility.



#TAR6  
**\$399<sup>00</sup>**  
pair

- 100 watt passive design with 6" woofer and 1" Neodymium titanium tweeter
- Ideal for professional near-field mixing, recording, post-production, and broadcast monitoring
- Extremely rigid design reduces distortion, improving driver performance and efficiency
- WideBand (SuperTweeter) provides smoother, extended high frequencies for richer harmonics and improved stereo imaging
- 65Hz-51kHz frequency response

## TANNOY Precision 8



Designed for professional recording and broadcast applications, the Precision 8's are passive 8" reference monitors capable of accurately handling up to 160 watts of total power. Their design implements advanced Dual Concentric driver technology, uniquely combining both high- and low-frequency drivers onto

one axis for precise timing, focus and articulation. Additionally, WideBand (SuperTweeter technology) further extends the high-frequency range, effectively producing a smoother overall response with rich harmonic detail. Ideal for powerful, critical monitoring.

- 160-watt passive design with 8" LF driver, 1" HF driver and extended range SuperTweeter
- Dual Concentric technology for superior time alignment, imaging and transient response
- Rigid, shielded, bass-reflex optimized cabinet design
- 56Hz-51kHz frequency response

**Precision 6** 6" version with 120-watt handling capability #TAP6.....**\$749.00** pair

#TAP8  
**\$949<sup>00</sup>**  
pair



**MACKIE****MR5**

The MR5 is a 2-way, 85-watts bi-amplified nearfield studio monitor designed for use in budget-minded project and home studios. The monitor's compact design allows for placement in small control room spaces as a stereo or surround mixing alternative. The magnetically-shielded monitor is equipped with rear-mounted HF and LF filter switches and an input level control.



#MAMR5  
**\$149<sup>99</sup>**  
pair

- 85 watts total power
- 5.25" polypropylene woofer, 1" waveguide silk dome tweeter
- MDF cabinet design with rear bass port for improved low-end response
- Balanced XLR and TRS, unbalanced RCA inputs
- 60Hz-20kHz frequency response
- 14.3 lbs (each)

**MACKIE****HR624mk2**

The HR624mk2 is a 2-way, 140-watt bi-amplified nearfield studio monitor boasting THX pm3 certification, designed for high-definition stereo or surround audio mixing for video, gaming and film applications. The cabinet design features full internal damping, an aluminum Zero Edge

baffle, and a passive radiator for minimized reflection distortion, improved imaging, and improved bass response. The rear panel includes HF and LF filtering, and an acoustic space selector switch.

- 140 watts total power
- 6.7" die-cast magnesium woofer, 1" titanium dome tweeter
- Optimized waveguide for larger "sweet spot"
- Balanced XLR and TRS, unbalanced RCA inputs
- 45Hz-22kHz frequency response • 23.4 lbs (each)

#MAHR624MK2  
**\$479<sup>99</sup>**  
pair

**MACKIE****MR8**

The MR8 is a 2-way, bi-amplified nearfield studio monitor with a 150-watt power reservoir and a rear bass port for enhanced low-end reproduction. The speaker is targeted toward the budget-conscious project or home studio owner in need of a stereo or surround speaker configuration in a small control room space. Modestly priced yet professionally equipped, the speaker sports both HF and LF filter switches and an input level control.

- 150 watts total power
- 8" polypropylene woofer, 1" waveguide silk dome tweeter
- Compact MDF cabinet design • Balanced XLR and TRS, unbalanced RCA inputs
- 40Hz-20kHz frequency response • 27.6 lbs (each)



#MAMR8  
**\$249<sup>99</sup>**  
pair

**TANNOY****REVEAL Active 5A**

The REVEAL 5A is a compact, 60-watt near-field monitor featuring a 5" woofer and 1" soft dome tweeter with many of the same professional characteristics of its big brother, the REVEAL 6D. Its rigid, precision-designed enclosure, tight, controlled bass response, and superior mid- and upper-range detail provide both musicians and engineers alike the increased clarity and accuracy required for dramatically improved final mixes.

- 60 watts combined power to 5" woofer and 1" dome tweeter • Rigid, distortion-free cabinet with low-diffraction baffle • Bass-reflex loaded design
- WideBand high-frequency driver provides open and detailed mids and highs
- XLR combo jack input
- 65Hz-30kHz frequency response

#TAR5A  
**\$698<sup>00</sup>**  
pair

**TANNOY****REVEAL Active 6D**

The REVEAL 6D's are versatile active near-field monitors that provide a combined 110 watts from a 6" woofer and 1" neodymium tweeter. They feature an extremely rigid, advanced symmetric cabinet design that combines an improved bass driver and Tannoy's WideBand high-frequency unit, producing tight, controlled bass, better phase control, and open, extended mids and highs. This design ensures better tonal accuracy of instruments and vocals, critical for allowing the best EQ and mix placement decisions.

- 110 watts combined power to its 6" woofer and 1" tweeter • Calibrated DIP switches for optimizing room acoustics and speaker placement
- Front baffle design provides an open detailed response with minimal distortion • Ideal for professional recording, editing and broadcast suites
- XLR, 1/4" TRS and 24-bit/96kHz S/PDIF digital (RCA) input



#TAR6D  
**\$1098<sup>00</sup>**  
pair

**ADAM**

**A7**

The A7 is a 2-way, 100-watt, bi-amplified studio monitor, with a ported bass-reflex cabinet design and extended HF frequency reproduction. The high-rigidity woofer has extensive internal damping and is surprisingly low in weight, which, combined with the proprietary tweeter offers highly accurate imaging and detail. The A7 is a fully professional nearfield solution, and a great value for the commercial or project studio owner.

- 100 watts total power
- 6.5" damped woofer, Accelerated Ribbon Technology tweeter
- Proprietary driver design for optimized clarity, imaging
- Front-panel power switch, volume control
- Rear-panel tweeter level control, HF/LF shelving filters
- XLR and RCA connectors
- 46Hz-35kHz frequency response • 17.8 lbs (each)



#ADA7  
**\$499<sup>50</sup>**

**ADAM**

**A5**

The A5 is a 2-way bi-amplified nearfield monitor featuring an ART technology ribbon tweeter with lightning-fast transient response and extended high frequency reproduction. The speaker offers high-end playback and room-control features along with a project studio price tag, including the Stereo-link function which allows the engineer to control the volumes of two speakers with a single volume knob.

- 50 watts total power
- 5" Rohacell/carbon fiber woofer, 1" ART ribbon tweeter
- ART technology tweeter for superior transient response and HF clarity • Balanced XLR and unbalanced RCA inputs
- 55Hz-35kHz frequency response • 11 lbs (each)



#ADA5B  
**\$349<sup>50</sup>** pair

- Piano Black** #ADA5PB..... **\$384.50**
- Piano White** #ADA5PW..... **\$384.50**

**KRK**

**VXT4**

The VXT4 is an active 2-way studio monitor with a ported bass-reflex cabinet and 45 watts of bi-amplified power. The curved design of the enclosure allows for solid imaging and a wide "sweet spot". The speaker is equipped with an unusually comprehensive set of switch controls, and supports multiple voltages for international use.

- 45-watt power output
- 4" woven Kevlar woofer, 1" silk dome tweeter
- 56Hz-22kHz frequency response
- XLR/TRS combo input
- HF and LF adjustment switches, level control knob
- 14 lbs (each)



#KRVXT4  
**\$299<sup>00</sup>** pair

**M-AUDIO**

**EX66**

The EX66 is a bi-amped 200-watt near-field monitor featuring advanced DSP in a vertical array design. This configuration provides optimal imaging and performance by eliminating many of the problems consistent with typical two-way designs. Two extremely linear six-inch drivers and a custom titanium tweeter are housed in an acoustically-efficient enclosure, producing a more revealing and accurate representation of music's subtle details.



#MAEX66  
**\$599<sup>95</sup>** each

- Bi-amped 200-watt monitor with dual custom 6" drivers and a 1" titanium tweeter
- Reduced vertical dispersion eliminates reflections improving image "sweet spot"
- DSP tuned cabinet with frequency response switches and Acoustic Space control
- 32-bit processing with digital I/O up to 192kHz (AES/EBU and S/PDIF)
- Balanced 1/4" TRS and XLR inputs
- 37Hz-22kHz frequency response

**M-AUDIO**

**StudioPhile BX5A**



#MABX5A  
**\$299<sup>00</sup>** pair

Ideal for personal studios and post-production editing suites, the M-Audio Studiophile BX-5's are an affordable bi-amplified 70-watt near-field monitoring system. Their efficient cabinet

design and unique Acoustic Space Control delivers great sound with outstanding value and features.

- 70 watts total power into 5" woofer and 1" tweeter
- Balanced/Unbalanced XLR/TRS inputs
- Magnetically shielded
- 56Hz-20kHz frequency response • 11 lbs (each)

**BX8A** 130 total watts, 8" woofer, 1" tweeter, 37Hz-20kHz response #MABX8A..... **\$499.00**

**SAMSON**

**Rubicon 5a**

The Rubicon 5a from Samson is a surprisingly affordable active ribbon monitor. The stand out feature of the Rubicon series is its uncommon 2" velocity ribbon transducer. Most studio monitors use tweeters that can artificially color the high frequencies, whereas a ribbon delivers a more natural response and a more even dispersion. 75 bi-amplified watts of power and a front ported wooden cabinet complete the package.



#SAR5A  
**\$299<sup>00</sup>**

- 75 Watts of power to its 5" woofer and 2" ribbon transducer
- 20Hz – 20kHz frequency response
- Volume level knob
- 4 position ribbon level switch
- TRS and RCA inputs

**Rubicon 6a** 100 total watts, 6" woofer, 2" ribbon, 20Hz–20kHz response #SAR6A .....**\$399.00**

**Rubicon 8a** 100 total watts, 8" woofer, 2" ribbon, 20Hz–20kHz response #SAR8A .....**\$499.00**

**YAMAHA**

**HS80M**



In the tradition of Yamaha's famous NS10M, the 120-watt HS80M is a true reference monitor providing an accurate representation of your mix. The rear panel features room control frequency switches so you can trust what you hear in its 42Hz – 20kHz

response. The attractive design features a white 8" polypropylene cone and a jet black cabinet to add a clean, sophisticated look to your production area.

- 120 watts of power to its 8" woofer and 1" dome tweeter
- Balanced XLR and 1/4" inputs
- Master volume control
- Room control frequency switches
- Illuminated front panel logo

**HS50M** 70 total watts, 5" woofer, 3/4" tweeter, 55Hz–20kHz response #YAH50M.....**\$199.95**

#YAH80M  
**\$349<sup>95</sup>**

**FOSTEX**

**NX-6A**

The unique NX-6A from Fostex offers 100 watts of bi-amplified power and an ultra-low ear fatigue design. Using the latest in radial papermaking technology, its 6.5" woofer features a UDR tangential driver edge that eliminates unwanted resonance for a smoother response. Pluses include an aluminum cast frame to cut down on unwanted resonance, and a magnesium tweeter to reduce metallic characteristics.



#FONX6  
**\$499<sup>00</sup>**

- 100 watts to its 6.5" woofer and 20mm tweeter
- 55Hz–38kHz frequency response
- Tweeter level control
- Low freq EQ boost/cut
- Output volume control

**EVENT**

**ALP5-N**



The Event ALP5-N is designed to deliver exceptional clarity in the midrange frequencies. Its molded enclosure utilizes a waveguide technology that features a phase-corrected baffle and a low-air-restriction frontal bass port. The result is a clean and present stereo image well-rounded in low and high frequencies. The ALP5 packs a large sound in a small footprint and delivers mixes that will translate.

- 80 Watts of power for its 5.25" woofer and 1" tweeter
- 53Hz–20kHz frequency response
- XLR, TRS, and RCA inputs
- Output current limiting
- RF interference protection

#EVALP5N  
**\$329<sup>00</sup>**

**BEHRINGER**

**B2030A**

The Behringer Truth B2030A is a remarkably affordable active near-field monitoring system. With 110 watts of amplification, these monitors put out an impressively high SPL level for their small size. With professional features like room compensation switches and a crossover network with 4th order Linkwitz-Riley filters, they're a powerful combination for the budget-minded project studio.



#BEB2030A  
**\$279<sup>99</sup>**

- 110 watts of power to its 6.75" woofer and .75" tweeter
- 50Hz – 21kHz frequency response
- High resolution ferro-fluid cooled tweeter
- Balanced XLR/TRS inputs
- Input level control

**B2031A** 225 total watts, 8.75" woofer, 1" tweeter, 50Hz–21kHz response #BEB2031A.....**\$339.99**



**BEHRINGER****B2092A**

The B2092A subwoofer from Behringer makes a powerhouse companion to the Truth series monitors and other professional monitoring systems. Dual 8" loudspeakers are driven by a 360-watt amplifier and housed in a sleek wooden enclosure. It's equipped with multiple balanced XLR inputs and outputs for stereo and surround mixing, as well as phase and room compensation switches for tonal accuracy.

- 360 watts supplied to its two 8" woofers
- Bass reproduction to 32Hz
- Footswitch input for A/B comparisons
- Crossover at 80Hz
- Band pass filter



#BEB2092A  
**\$229<sup>99</sup>**

**EVENT****TR6**

The Event TR6 is a cost effective monitor of exceptional quality, assuring that your mix will translate to different sound systems. This is achieved through its 80 watts of bi-amplified power, and split by an active 4th-order asymmetrical crossover. All of the Tuned Reference series are identical, so whether you need a stereo pair or a surround mixing system, the TR6 will deliver natural sounding accuracy.



#EVTR6  
**\$199<sup>50</sup>**

- 80 Watts of power to its 6" woofer and 1" tweeter
- 45Hz–20kHz frequency response
- Rear input sensitivity controls
- Balanced XLR/TRS and RCA inputs
- RF interference protection

**E-MU****PM5**

The PM5 from E-Mu is a compact active near-field monitoring system designed to deliver a clear high frequency response at an affordable price. Bi-amplified with 80 watts of power with a dual mode LED on the front panel to alert the user of overload, the PM5 is well equipped with features to deliver professional mixes for today's production studio.

- 80 watts of power to its 5" woofer and 1" soft dome tweeter
- Bass and treble sensitivity controls
- Balanced and unbalanced combo input
- Magnetically shielded
- 67Hz to 20kHz frequency response

#EMPM5  
**\$249<sup>99</sup>**

**BEHRINGER****B2031P**

#BEB2031P  
**\$159<sup>99</sup>**

The Behringer B2031P is an inexpensive passive near-field monitor with a long-throw 8.75" woofer and a 150-watt power handling capacity. The sizable cone and ferro-fluid cooled tweeter combine to provide a wide stereo image utilizing Behringer's wave guide technology. Delivered in factory matched pairs, the Behringer Truth series of monitors are an exceptional value.

- 150-watt power capacity
- Phase optimized crossover
- 55Hz–21kHz frequency response
- Low-vibration MDF cabinet
- Binding post connectivity

**B2030P** 6.75" version with 100-watt power handling capability #BEB2030P.....**\$129.95**

**FOSTEX****PM-1 MKII**

The PM-1 MKII is a 2-way, 120-watt bi-amplified nearfield studio monitor with dual front baffle-mounted ports on the cabinet for enhanced bass response. Fostex has emphasized the use of unusual construction materials for the cone and tweeter as a means of achieving low distortion and optimized frequency reproduction. The result is a punchy, high-output speaker that is a welcome addition to the project studio monitor market.

- 120 watts total power
- 6.5" woofer, 1" soft dome tweeter
- Fiber and resin-impregnated woofer, polyurethane cloth tweeter
- Precisely-calibrated amplifiers match drivers
- Input sensitivity control
- XLR/1/4" Combo connectors
- 50Hz-20kHz frequency response
- 22.9 lbs (each)



#FOPM1MK2  
**\$379<sup>00</sup>**  
*pair*

## KRK RP-5

The popular KRK RP-5 is known for packing a large sound in a small footprint. Its sonic clarity is achieved through its distinctive yellow 5" woofer, made from a woven glass aramid composite, and its 1" ferro fluid-cooled neodymium soft dome tweeter. The RP-5's enclosure features radiused corners to minimize diffraction, and an electronic crossover to deliver a natural response efficiently.

- Bi-amplified 75 Watts of power to its 5" woofer and 1" tweeter
- Balanced TRS and XLR and unbalanced RCA inputs
- 53Hz–20kHz frequency response
- Compact size • Video shielded

**RP-6** 100 total watts, 6" woofer, 1" tweeter, 48Hz-20kHz response #KRRP6.....**\$199.50**

**RP-8** 140 total watts, 8" woofer, 1" tweeter, 45Hz-20kHz response #KRRP8.....**\$249.50**



#KRRP5  
**\$149.50**

## SAMSON StudioDock 4i



The StudioDock 4i is a pair of self-powered computer speakers designed for desktop multimedia and gaming audio playback monitoring. The speakers feature 40 watts of power,

an iPod docking station, a USB port, headphone monitoring, and magnetically shielded woofers for close-proximity use with computer monitors

- 40 watts total power
- 4" co-polymer woofer, 1" silk dome tweeter
- Desktop computer monitoring with USB port and iPod dock
- 1/8" stereo mini input, 1/8" stereo mini headphone output
- Full-range frequency response

**StudioDock 3i** #SASD3I.....**\$149.00**

#SASD4I  
**\$199.00**

## M-AUDIO Studiophile AV 40

The Studiophile AV 40 is a 2-way, 40-watt desktop audio monitoring system with trendy, vinyl-laminated MDF speaker cabinets. The left speaker, which houses the I/O connectors, power switch, and volume control also sports a headphone output, and a supplied cable provides connection to the right speaker. Magnetically shielded and efficient, the Studiophile AV 40 is a good solution for multimedia audio production requirements.

- 40 watts total power • 4" polypropylene-coated woofer, 3/4" silk dome tweeter
- Ported bass-reflex cabinet rear • Voltage selector switch
- Bass-boost switch for extra LF response • 1/4" and RCA connectors
- 85Hz-20kHz frequency response • 14 lbs



#MASPAV40  
**\$149.00**

## M-AUDIO DX4



- 18 watts per channel • 70Hz – 20kHz frequency response • Custom tuned cabinet
- Mid-cut switch • Front headphone input

M-Audio's DX4 desktop monitoring system combines the power of a 36-watt amplifier and the sonic clarity of its Optimage dispersion-controlled wave guide. The coated 4" woofer and its 1" mylar cone bring richly detailed sound to users in media production, gaming, or just pure listening pleasure. Professional balanced 1/4" inputs in the rear panel are provided for premium sound quality.

#MADX4  
**\$149.00**

## M-AUDIO BX10s

The rapid proliferation of surround sound systems has greatly increased the importance of mixing with a subwoofer, so M-Audio's new BX10s was designed to integrate seamlessly with your current monitoring system. Near field monitors plug into its XLR inputs, and a user-definable integrated crossover splits the signal. A footswitch is included to bypass the sub and crossover so you can hear how your work translates without the deeper bass.

- 240 watts of power to its 10" woofer
- Adjustable 50 – 200Hz crossover
- Auto settings for Dolby Digital, DTS, and THX • Intelligent on/off sleep function • Video shielding



#MABX10S  
**\$399.00**

## EDIROL MA-15D

The Ediol MA-15D is a multi-media production monitor with a variety of features and 15 watts of power per channel. Its attractive design and front panel controls make it ideal for both professional purposes and for just enjoying music on your computer. Offering both optical and coaxial digital inputs in addition to analog RCA and 1/8", the MA-15D allows you to monitor two sources independently with high-quality sound performance.

- 15 watts per channel onto a 4" woofer 2" tweeter • Optical and coaxial digital inputs • 24-bit 192kHz digital to analog converters
- Bass enhancer • Front panel headphone jack



#EDMA15D  
**\$179<sup>00</sup>**

## EDIROL MA-7



When desk space is at a premium and sound quality is a must, the MA-7 from Ediol is the answer. Its 3" speakers with 7-watts of power and front panel bass ports provide excellent sound whether you're working on multi-media projects or using your computer for leisure. Rear RCA inputs allow connection to the sound source, and an 1/8" input on the front allows a second device to be monitored.

- 7 watts of power to its 3" full-range driver • Front bass and treble controls
- Magnetically shielded • Enhanced bass response • Multiple inputs

#EDMA7  
**\$99<sup>00</sup>**

## ALESIS M1Active 320 USB

The M1Active 320 USB is a compact and inexpensive set of active desktop monitors with a 10-watt amplifier and a plug-and-play USB computer connection. Intended for multi-media and other desktop production applications, these shielded speakers also act as an audio interface, replete with connectors for CD and MP3 players, musical instruments and other devices, for playback or direct recording purposes.

- 10-watts total power, 3" Woofer and 1" Silk Dome Tweeter
- Plug-and-Play USB cross platform computer connectivity
- 1/8" stereo mini, stereo RCA and 1/4" inputs • 1/4" front panel headphone output
- Switchable bass boost and rear bass ports, Volume control • Switchable power supply
- 80Hz-20kHz frequency response • 7.5 lbs (total)



#ALM1A320  
**\$99<sup>00</sup>**

## YAMAHA MSP3

With versatile mixing control, the Yamaha MSP3 stands out as a convenient and powerful desktop production monitor.

Its balanced and unbalanced inputs have separate volume controls on the front, allowing the user to tailor mix two signals. Hi and low EQ controls are also included in front to customize tonality. The enclosure utilizes Yamaha's Waveguide Technology for uniform frequency dispersion.

- 20-Watt amplifier for its 4" woofer and 7/8" tweeter
- Balanced XLR/TRS and unbalanced RCA inputs
- Hi and low tone control • Separate input volume controls • Magnetic Shielding



#YAMSP3  
**\$149<sup>00</sup>**

## EDIROL MA-1EX



The Ediol MA-1EX provides an easy way to improve the sound quality of a laptop or desktop computer. Ultra-portable, the MA-1EX gets its power from the computer's USB connection, and offers an additional digital optical output to send the computer's audio to another source. A retractable integrated USB cable and headphone jack provide everything for the person on-the-go.

- 1.5-watts and a 2" full-range speaker
- USB powered
- Digital optical output
- Volume control and headphone output

#EDMA1EX  
**\$49<sup>00</sup>**



**NEUMANN**

**BCM104**

With precision engineering and design, the Neumann BCM104 is a natural-sounding, large diaphragm cardioid condenser microphone, specifically tailored for the demands of today's digital broadcast studios.

- Cardioid microphone for broadcast & studio
- Internal switchable low-frequency roll-off
- 14dB pad
- Switchable proximity compensation
- Easily switchable color coded head grilles
- Unique shock mount assembly
- 152dB SPL
- 20Hz–20kHz frequency response

#NEBCM104  
**\$999<sup>99</sup>**



**BCM104** voice-over kit #NEBCM104K.....**CALL**



**RODE**  
**BROADCASTER**

An affordable choice for today's modern digital broadcast facilities, the RODE BROADCASTER is a large diaphragm cardioid condenser microphone that features a true full-range response especially suited for voice-over use.

- Low noise handling
- Unique "On-Air" LED indicator
- Internally shock-mounted capsule with pop filter
- Power indicator
- 135dB SPL
- 20Hz–20kHz frequency response
- Custom case with microphone holder (included)

#ROB  
**CALL**

**Broadcaster** voice-over kit #ROBK.....**CALL**

**SHURE**

**SM7B**

The Shure SM7B is a large diaphragm dynamic microphone designed for studio broadcast applications. It has a smooth, flat, wide-range frequency response, and provides excellent shielding against electromagnetic hum generated by computer monitors, neon lights, and electrical devices.

- Selectable tone controls
- Internal suspension shock mount
- Graphic display of bass and mid-range adjustments
- Improved bracket design
- High sound pressure level handling capabilities
- Rugged steel construction
- 40Hz–16kHz frequency response

#SHSM7B  
**\$349<sup>95</sup>**



**SM7B** voice-over kit #SHSM7BK .....**\$499.95**



**ELECTRO-VOICE**  
**RE20**

A broadcast industry standard, the Electro-Voice RE20 is a cardioid dynamic microphone that delivers reliable, low-noise performance with exceptional clarity and definition. Its internal pop filter reduces proximity effect, and the internal shock mounting reduces handling noise.

- Response tailored for vocal applications
- Bass tilt down Switch
- Capable of extremely high sound pressure levels
- Rugged steel construction with low handling noise
- 45Hz–18kHz frequency response
- Includes 81715 stand clamp

#ELRE20  
**\$399<sup>00</sup>**

**309A** suspension shock-mount available #EL309A ..... **\$99.00**

**RE20** voice-over kit #ELRE20K.....**\$649.95**

**NEUMANN**

**BCM705**

The BCM705 is Neumann's first ever dynamic microphone, and its second in the Neumann broadcast line. Housed in the same body as the BCM104, it utilizes a Neumann re-designed version of the Sennheiser MD 431 capsule, overhauled to meet the specific demands of broadcast applications.

- Supercardioid pickup pattern
- Removable integrated wire mesh pop screen
- Individual head grilles available for each user
- Capsule's mechanical suspension reduces sensitivity to stand movement or handling shocks
- Does not require a power supply
- Frequency response: 20Hz–20kHz
- Integrated elastic suspension

#NEBCM705  
**\$699<sup>00</sup>**



**BCM705** voice-over kit #NEBCM705K.....**CALL**

**AUDIO-TECHNICA****AT825**

The Audio-Technica AT825 is an easy-to-use, single-point-reference stereo condenser microphone. Its flat frequency response and "true" stereo imaging make it the right choice for recording music, on-location audio, or ambient soundscapes onto professional DV cameras, compact flash, and DAT recorders.

- Closely-matched elements provide outstanding imaging and excellent channel separation
- Compact, lightweight design is ideal for camera mounting
- Switchable low-frequency roll-off
- 5-pin XLR output • 126dB SPL
- 30Hz–20kHz frequency response

#AUAT825  
**\$349<sup>95</sup>**



**AT822** unbalanced version with 1/8" stereo or 1/4" dual mono termination  
#AUAT822..... **\$249.00**



- Two externally biased 1/2" matched capsules with gold-sputtered diaphragms
- Transformerless circuitry for low noise
- Phantom or 9V battery-powered
- 143dB SPL • 20Hz–20kHz frequency response
- Custom mini stereo jack and XLR cables included
- Custom case, shock mount, windshield, and stand mount supplied

**RODE**  
**NT4**

#RONT4  
**\$479<sup>00</sup>**

The RODE NT4 is a fixed, 90-degree X/Y configuration stereo microphone designed for professional applications. Its perfectly matched cardioid condenser elements produce both detailed and accurate stereo recordings. The NT4 can be powered via phantom or 9V battery, making it well suited for both studio and location recording.

**SHURE****VP88**

The Shure VP-88 is a professional single-point reference stereo condenser microphone. Ideal for location, broadcast and live performance recordings, the VP-88 features a unique selectable stereo imaging matrix output and filter adjustments that provide recording and broadcast engineers with the flexibility necessary to capture the realism of live events faithfully.

#SHVP88  
**\$689<sup>95</sup>**



- Mid-Side design for optimal imaging
- Built-in stereo matrix for direct stereo spread control
- Selectable roll-off and output
- Internal shock mount for reduced handling noise
- Operates on both phantom or internal 6V battery power • 129dB SPL
- 40Hz–20kHz frequency response

**CROWN**  
**SASSP MKII**

The SASSP MKII is an ambient stereo microphone that utilizes dual PZM microphone elements. Its unique design mimics the shape of the human head to capture an airy and warm complete stereo image. Broadcasters rely on it for recording crowds, journalists and filmmakers use it for realistic ambience, and it's also used experimentally in recording studios for music and soundtrack production.

- Stereo electret condenser Pressure Zone Microphone (PZM)
- 12V – 48V phantom powered or two 9V batteries
- Omni at low frequencies, unidirectional at mid/high frequencies
- Low cut switch • 150dB SPL • Carrying case, handgrip, and windscreen included
- 20Hz–18kHz frequency response

#CRSASSMK2  
**\$1104<sup>50</sup>**

**SONY****ECM 957 Pro**

The ECM-957PRO is a MS (Mid-Side) stereo condenser microphone with switchable directional characteristics (90° or 120°). It allows for a choice of vertical or horizontal sound pick-up its built-in MS decoder providing a conventional left and right stereo output. The ECM 957 Pro is supplied with a 5-pin XLR to mini (1/8") mic cable and operates approximately 200 hours on a single AA size battery.

#SOECM957PRO  
**\$348<sup>95</sup>**

- Mid-Side stereo condenser microphone
- Switchable directivity (90° or 120°)
- Adjustable mic capsule for vertical or horizontal sound pick-up
- Built-in MS decoder
- Includes 5-pin XLR cable to stereo mini cable
- Powers via a single AA battery (approximately 200 hours)



**NEUMANN**

**KMR81i**

#NEKMR811  
**\$1399<sup>99</sup>**



The KMR81i is a premium shotgun microphone designed especially for ENG, film, and stage work. Off-axis sounds are left uncolored and are picked up at low levels, while the outstanding directivity allows focus on individual sources producing clean, high-output sound with remarkably low self-noise. Attenuation and filter switches further enable level and noise control.

- Renowned Neumann engineering
- Low power consumption, lightweight, and wind resistant
- 10dB pad and high-pass filter

- Excellent directional characteristics with superior side and rear rejection
- 48V phantom powered

**KMR82i** supercardioid long-tube shotgun with enhanced high frequencies

#NEKMR821..... **\$1599.99**



**SCHOEPS**  
**CMIT 5U**

#SCCMIT5U  
**\$1999<sup>00</sup>**

- Supercardioid polar pattern
- Superior RF immunity
- Low colorization of off-axis sound
- (3) pushbutton-activated filters with LED's
- Lightweight, blue anodized all-metal housing
- Includes: SG 20 swivel joint, W 140 windscreen and wooden carrying case
- Frequency response: 40Hz-20kHz

The CMIT 5U is a shotgun microphone that delivers the exacting standards, reliability, and neutral, accurate sound Schoeps microphones are known for. It is equipped with three pushbutton-activated filters: High-frequency emphasis (+5 dB at 10 kHz), Steep low-cut filter (18 dB/oct. below 80 Hz) and Gentle low-frequency rolloff (6 dB/oct. below 300 Hz). This top quality shotgun microphone is suitable for both music and dialog recording.

**SANKEN**

**CS-3e**

The CS-3e is a short shotgun microphone with a unique design, incorporating three directional capsules arranged in a front-back array. It maintains directivity over a wide frequency range (especially in the low frequencies) and minimizes proximity effect. The CS-3es standard 19mm diameter permits the use of a wide range of mounts, wind protection and accessories.

- Excellent for noisy ambient environments
- Supercardioid polar pattern
- Switchable low-cut filter
- Directional sound even in the lower frequencies
- Excellent side and rear rejection with low proximity effect
- Frequency response: 50Hz -20kHz
- Brass housing with black soft-touch coating



#SACS3E  
**\$1350<sup>00</sup>**

**SANKEN**

**CS1**

#SACS1  
**\$795<sup>00</sup>**

The CS1 is a compact shotgun microphone that combines a cardioid pattern and excellent off-axis rejection to produce crisp, focused sound that is ideal for professional film, video, and broadcast productions. The lightweight CS1 conveniently mounts onto cameras and can handle high sound pressure levels suitable for reproducing distortion-free audio at even close proximities.

- Designed for professional videographers, TV/film, and broadcast applications
- Very high SPL handling capability
- Narrow angle, directional pickup rejects off-axis ambience
- 48V phantom powered

**K-SSM** K-Tek shock mount for Sanken CS1

#KTKSSM..... **\$119.95**



**SENNHEISER**

**MKH416**

#SEMKH416P48  
**\$1099<sup>95</sup>**

The MKH416 is a highly sensitive short shotgun microphone designed to deliver extremely linear low-noise audio with minimal off-axis sound coloration, a favorite for high-end film production, TV/video and broadcast applications. Its rugged RF-design is virtually immune to weather conditions and mounts easily to fish poles, booms, and digital cameras.

- High-end, low-noise design for demanding film, ENG and video production
- Excellent directivity and compact design
- Transformerless, natural sound
- Highly-sensitive element effectively rejects feedback and off-axis sound
- 48V phantom powered
- Rugged build, suitable for adverse climates





**SENNHEISER**

**MKH60**

#SEMKH60  
**\$1539<sup>95</sup>**



The MKH60 is a short shotgun microphone designed with a high degree of directivity ensuring superior audio quality for distance applications. Ideal for a variety of professional film and broadcast applications, the low noise, low distortion MKH60 features a light, weather-proof design that maintains a natural, sensitive response throughout the whole frequency range.

- High directivity throughout whole frequency range
- Excellent side and rear noise rejection
- Natural sounding transformerless design
- Rugged and weather-proof
- Switchable pre-attenuation
- Switchable roll-off filter
- Switchable treble emphasis



**SENNHEISER**  
**MKH-70**

#SEMKH70  
**\$1699<sup>95</sup>**

The MKH-70 is a long shotgun condenser microphone that provides frequency-independent directivity; preventing sound coloration from off-axis sound sources. This microphone provides excellent directivity, making it ideal for long-distance miking applications and high noise environments. Its RF condenser element offers high sensitivity with very low inherent self-noise.

- Ideal for film and ENG applications
- Exceptionally low inherent self-noise
- Switchable roll-off filter, treble emphasis and 10dB pad
- Powers via: 48V phantom power
- Lightweight, rugged, and weather-proof
- Frequency response: 50Hz-20kHz
- Black, anodized metal casing

**AUDIO TECHNICA**

**AT-4071A**

#AUAT4071A  
**\$659<sup>95</sup>**

The AT-4071A is a shotgun microphone designed for critical long-distance pickup in broadcasting, film/TV production, and theater sound reinforcement applications. Its unique interference tube design provides the same directivity as mics up to 50 percent longer than the AT-4071A. The rugged 15.55" housing is made of lightweight structural-grade aluminum alloy, and weighs only 5.5oz.

- Lightweight design for boom pole operation
- Extremely high output with low noise floor
- Switchable 150Hz hi-pass filter
- Frequency response: 30Hz-20kHz
- Rugged aluminum-alloy housing
- Includes: snap-in stand clamp, foam windscreen & carrying case



**SHURE**

**SM89**

#SHSM89  
**\$629<sup>95</sup>**

The SM89 is a professional shotgun microphone designed especially for location film/TV production, theater sound reinforcement, and spot pickup. The rugged and reliable SM89 is made from aircraft-grade materials and operates over a wide range of temperature and humidity. Its lightweight design enables it to be suspended on a fishpole for long periods of time without operator fatigue. Designed to produce a smooth, wide on-axis response, the SM89 is optimized for cutting through noisy environments and has a slight presence boost for increased clarity and speech intelligibility.

- Highly directional polar pattern
- 2 low-cut frequencies for reduced mechanical noise
- Greatly suppressed side pickup
- Very lightweight with low hum, noise, and RF pickup
- Wide range phantom power operation
- Frequency response: 60Hz-20kHz
- Includes: foam windscreen and carrying case



**SENNHEISER**

**ME66 K6**

#SEME66K6J  
**\$479<sup>00</sup>**

The ME66 is a short shotgun microphone capsule designed especially for reporting, film, and broadcast applications. It is capable of picking up quiet signals in noisy or acoustically live environments. It has a highly directional supercardioid pickup pattern, low self-noise, and high sensitivity for greater gain-before-feedback.

- Excellent off-axis noise rejection for increased accuracy in high-noise environments
- Ideal for videography, field recording, interviews, film and broadcast production
- Compact design for use on short digital cams
- Supplied with K6 power supply for phantom or battery use



**ME67** supercardioid spot shotgun condenser microphone capsule #SEME67 ..... **\$269.95**

## RODE NTG-1

#RONTG1  
**\$249<sup>00</sup>**

The Rode NTG-1 is a supercardioid condenser shotgun microphone specifically designed for professional ENG, film, video, and voice-over applications. It powers via phantom power, and provides a controlled polar response coupled with low noise SMT electronics. This extremely lightweight microphone mounts directly to video cameras (with optional accessories) or boom poles.

- Supercardioid condenser shotgun microphone
- Ideal for camera or boompole mount
- Switchable high-pass filter
- Frequency Response: 20Hz- 20kHz
- Very low self-noise
- Rugged metal construction
- Includes: stand mount, zip pouch, and foam windshield



## RODE NTG-2

#RONTG2  
**\$269<sup>00</sup>**

The NTG-2 is a lightweight condenser shotgun microphone designed for professional film, video, and production applications. It can power either from an internal AA battery or 48V phantom power, making it ideal for mounting directly to video cameras or boompoles. This low-profile mic provides a wide bandwidth, a controlled polar response and a high-pass filter to cut out low-end rumble.

- Mounts directly to video cameras or boompoles
- Powers via: AA battery or phantom power
- Switchable high-pass filter
- Frequency response: 20Hz -20kHz
- Rugged metal construction
- Includes: zip pouch, RM5 stand mount, and foam windscreen

## AUDIO TECHNICA AT-875R

#AUAT875R  
**\$199<sup>95</sup>**

The 875R is an exceptionally compact shotgun microphone that was designed for use in video production. Its abbreviated length (seven inches) makes it ideal for mounting on a video camera. It offers off-axis rejection of sounds to the sides and rear of the mic, and the sound quality and performance of a larger, more expensive shotgun microphone.

- Requires phantom power in order to operate
- Short seven-inch length
- Tailored low frequency response
- Smooth audio reproduction
- Ideal for mounting on a video camera
- Excellent off-axis rejection



## AUDIO-TECHNICA AT8035

#AUAT8035  
**\$239<sup>95</sup>**

The AT8035 is designed for professional recording, broadcasting and TV/film video production. It provides the optimum acceptance angle for picking up clean audio at long distances, even in acoustically noisy environments. Additionally, its short length is well suited for ENG, outdoor recording, and other specialized uses.

- Designed especially for video and broadcast (boom or handheld use)
- Excellent rear and side sound rejection
- Switchable low-frequency rolloff
- Operates on battery or phantom power



## AUDIO-TECHNICA AT897

#AUAT897  
**\$269<sup>95</sup>**

Designed to capture audio accurately from a distance, the AT897 is considered the benchmark for lower-priced short shotgun microphones. Its compact length mounts conveniently on a DV camcorder without adding much heft or getting in the frame. It provides a smooth, natural on-axis sound with excellent rear and side rejection.

- Designed for field audio use in film/TV/video production and broadcast
- Short, compact design ensures mic stays out of the shot
- Smooth, natural-sounding on-axis audio
- Low-cut filter • 48V phantom or battery operation



**AT8415** low-profile shock mount #AUAT8415..... **\$49.95**

## SONY ECM-674

#SOECM674  
**\$345<sup>00</sup>**



The ECM-674 is a lightweight shotgun condenser microphone that combines high performance features with versatile powering options at an affordable price. It provides high sensitivity, low-noise characteristics and a flat, wide frequency response. Designed for use in both studio and field applications, the compact ECM-674 is an ideal match for Sony's HDV, DVCAM and XDCAM camcorder lines.

- Compact, lightweight design
- Powers via: AA battery or external phantom power
- 2-position low frequency roll-off switch
- Frequency response: 60Hz-18kHz
- Built-in battery liquid leakage protection circuit
- Includes: windscreen, mic holder, mic spacer, and cable



- Compact super-cardioid short shotgun
- Built-in, 2-position low-cut filter
- Powers via: 48V phantom power
- Frequency response: 40Hz-20kHz
- Camera and boom-pole mountable
- Includes: a wind-screen, holder, spacer, and carrying case

## SONY ECM-678

#SOECM678  
**\$650<sup>00</sup>**

The ECM-678 is a compact, short shotgun microphone designed for use in broadcast, professional video, film, and field audio applications. This durable mic can be mounted on a boompole or a video camera and is suitable for even the most demanding shooting/recording conditions. It is equipped with a newly-developed microphone capsule that delivers sensitivity of -28dB and extremely low inherent noise of less than 16 dB SPL.

## SONY ECM 673

#SOECM673  
**\$295<sup>00</sup>**

The ECM-673 is a compact shotgun microphone designed for use with compact camcorders in broadcast, documentary, and motion picture production. This lightweight microphone weighs only 4.9 ounces and is only 8 inches long. It provides sensitivity of 36dB, 40 Hz to 20 kHz frequency responses and a built-in, two-position low-cut filter.

- Low-profile shotgun, ideal for videographers
- Built-in, 2-position low-cut filter
- Powers via 48V phantom power
- Weight: 4.9 ozs, Length: 8"
- Frequency responses: 40Hz- 20kHz



- Includes: windscreen, mic holder, mic spacer, & cable

## AUDIO-TECHNICA AT4073A

#AUAT4073A  
**\$549<sup>95</sup>**

Designed for critical long-distance pickup, the AT4073A sets a new standard for small, lightweight shotgun microphones.

It mounts easily to minicams and fish poles and features a proprietary interference tube whose narrow acceptance angle provides the same directivity as mics up to fifty percent longer.

- Ideal for broadcast, film/TV, video, and stage sound reinforcement
- Patented acoustic design provides directivity of mics 50% longer
- Superior off-axis sound rejection
- Switchable 150Hz hi-pass filter
- Wide 11-52V phantom power operation



## AUDIO TECHNICA AT-8015

#AUAT8015  
**\$279<sup>95</sup>**

The AT-8015 is a long shotgun designed for professional video production, broadcast, and ENG/EFP applications. It powers via battery or phantom power, and provides excellent sound rejection from the sides and rear of the microphone.

The AT-8015 is equipped with a low frequency roll-off switch to help reduce ambient noise, room reverberation and mechanically-coupled vibrations.

- Designed for broadcast and film/TV/video production
- Excellent sound rejection from the sides and rear of mic
- Switchable low frequency roll-off
- Frequency response: 30Hz-20k Hz
- Powers via: AA battery or phantom power
- Includes: stand clamp, AT8135 windscreen, battery, carrying case





## AZDEN SGM-2X

The SGM-2X is a shotgun microphone system designed for both the pro sound and broadcast markets. This dual-purpose mic has two interchangeable barrels: an 8 1/8" omnidirectional barrel, and an extension barrel to make it a 15 3/4" supercardioid. It operates for 250+ hours on a single AAA battery and includes a unique, integrated shock-mount and two foam windscreens.

#AZSGM2X  
**\$219<sup>95</sup>**



- Professional shotgun microphone system
- Switchable low-cut filter
- Frequency response: 40Hz -20kHz
- Powers via: AAA battery
- Low current drain, 250+ hour battery life
- Camera-shoe or stand mounting
- Includes: shock mount mic holder, (2) windscreens



- Ideal for videographers
- Hyper-directional, supercardioid shotgun microphone
- Frequency Response: 18Hz -80kHz

- 110dB SPL
- Powers via: AAA battery
- Low current drain, 1000+ hour battery life
- Camera-shoe or stand mounting
- Includes: windscreen and integrated shock mount

## AZDEN SGM-1X

The Azden SGM-1X is a compact shotgun microphone designed for mounting on digital video cameras. This hyper-directional supercardioid shotgun has a wide frequency response and will operate over 1000 hours on a single AAA battery. It includes a windscreen and Azden's proprietary shock-mount holder that isolates the SGM-1X from camera motor and handling noise.

#AZSGM1X  
**\$149<sup>95</sup>**

## AZDEN SGM-1000

The SGM-1000 is a highly directional shotgun microphone that can be powered by external phantom power or a single AA battery. This versatile microphone provides a wide frequency response, a switchable low-cut filter, and a unique shock-mount holder with integrated shoe mount. When powered via alkaline battery, the SGM-1000 will operate for approximately 1000 hours.

#AZSGM1000  
**\$299<sup>95</sup>**

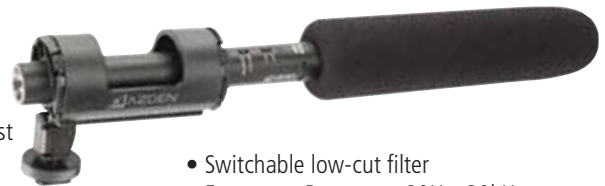

- Ideal for video, ENG, and broadcast applications
- Supercardioid electret condenser
- Powers via: AA battery or phantom power

- Switchable low-cut filter
- Frequency Response: 80Hz -20kHz
- Low current drain, 1000+ hour battery life
- Includes: shock mount mic holder, windscreen and carry-pouch

## CRYSTAL PARTNERS

### Big Ears Super Kit

#### Parabolic Microphone Kit

The Big Ears Super Kit is the latest generation of the state of the art parabolic microphone reflector. It incorporates two side mounting plates in the handle design to accommodate mounting of transmitters and receivers for wireless communications.

**Big Ears Super Kit includes:**  
BE3 dish, HD1 Headset, MD1 Bridging Amp and Sennheiser MKE2 Microphone, CC1 carrying case, RD1 electronic site, DS1 neck strap and SG1 silent gloves.

- Pick-up Pattern: 30" diameter target at 100ft. (tunable)
- Useful Range: 5ft. to 500+ ft. maximum (dependent on environment, atmospheric conditions and surrounding noise levels)
- Size: 25.5" x 26.5" x 10" • Parabola size: 23" • Weight: 5 lbs

*This Parabolic Microphone kit is not recommended for Tactical use*



#CRBE3KSC  
**\$4499<sup>00</sup>**

## CRYSTAL PARTNERS

### Lil Ears Super Kit

#### Parabolic Microphone Kit

The Lil Ears Super Kit is the ENG version of the state of the art parabolic microphone reflector. This ready to use broadcast package complete with handle and yolk, and is designed for hand held, mic stand or camera mount.

**Lil Ears Super Kit Includes:**  
BE4 dish, HD1 Headset, MD1 Bridging Amp and Sennheiser MKE2 Microphone, CC2 carrying case, RD1 electronic site, DS1 neck strap and SG1 silent gloves.

- Pick-up Pattern: 24" diameter target at 100ft. (tunable)
- Useful Range: 3ft. to 350+ ft. maximum (dependent on environment, atmospheric conditions and surrounding noise levels)
- Size: 16" x 15" x 5" overall • Parabola size: 13" • Weight: 2 lbs

*This Parabolic Microphone kit is not recommended for Tactical use*



#CRBE4KSC  
**\$2999<sup>00</sup>**

**AUDIO TECHNICA****BP-4029**

The BP-4029 is a professional stereo shotgun microphone designed for long-distance miking in broadcasting and film/TV production applications. It features independent line-cardioid and figure-of-eight condenser elements, switchable low-frequency roll-off and a selection switch for non-matrixed M-S and internally matrixed left/right stereo modes. This lightweight mic's compact design makes it an ideal choice for camera mounting.

- Independent line-cardioid and figure-of-eight condenser elements
- M-S, LR Stereo-Wide, and LR Stereo-Narrow modes
- Switchable low frequency roll-off
- Frequency response: 30Hz-20kHz

#AUBP4029  
**\$699<sup>00</sup>**



- Includes: 24" 5-pin XLR/F-(2) XLR/M cable, stand clamp, AT8135 windscreen, carrying case



- Ideal for film, ENG and broadcast applications
- Polar Pattern-M: Supercardioid, S: Figure 8
- Low inherent self-noise

- Dual channel 5-pin XLR Output
- Frequency Response: 40Hz- 20kHz
- Matte black metal casing
- Includes carrying case

**SENNHEISER****MKH-418 S**

The MKH 418 S is an M-S stereo shotgun microphone that combines a supercardioid mid capsule with a newly designed figure-of-eight side capsule. A 5-pin XLR output sends the separate signals of each internal microphone system to discrete channels on a console/field mixer, recorder or matrixing system. This versatile mic utilizes Sennheiser's exclusive RF condenser technology; offering low inherent self-noise and an optimal signal-to-noise ratio.

#SEMKH418S  
**\$1529<sup>95</sup>**

**NEUMAN****RSM 191 A-S**

The RSM 191 is a remote-control shotgun system for MS and XY stereo recording. It consists of a short shotgun microphone with two separate capsule systems (hypercardioid element and figure-8), and the MTX 191, a matrix amplifier that controls the width of the stereo image. The RSM 191 is ideal for use as a stereo drum overhead system, and is equally well suited for broadcasting/ENG, film and video applications.

#NERSM191AS  
**\$4799<sup>00</sup>**

- MS-stereo microphone, switchable to XY configuration
- Polar Pattern: Mid-hypercardioid, Side-, figure-8
- Switchable low frequency roll-off
- Frequency response: 20Hz -20kHz
- Powers via: phantom power or 9V battery
- Includes: aluminum carrying case, windscreen, interconnection cable and dual 3-pin XLR output cable

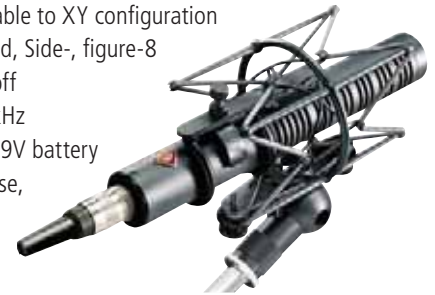
**SANKEN****CSS-5**

The CSS-5 is an easy-to-operate stereo shotgun for use in stereo broadcasts and feature films with stereo and surround sound. Its unique design utilizes an array of five directional condenser elements, offering three distinct operation modes to satisfy the various needs of location and studio recording. The CSS-5 standard 19mm diameter permits the use of a wide range of mounts, wind protection, and accessories.

- Ideal for film, video, and broadcast applications
- 3 switchable modes: Normal, Mono, Wide
- Excellent side and rear rejection with low proximity effect
- Equally responsive in the horizontal and vertical planes
- Frequency response: 20Hz -20kHz
- Standard 19mm diameter

**GS-5** Pistol Grip w/Shock mount for CSS-5 #SARYGS5..... **\$245.00**



#SACSS5  
**\$1995<sup>00</sup>**

**SANKEN****CMS-10**

The CMS-10 is a camera-mount stereo shotgun microphone designed for HDTV broadcasting applications. It provides extremely high-resolution audio, superior frontal directionality and an integrated camera mount suspension. The CMS-10's output is switchable between a highly-directional mono signal to both L/R channels and a L/R stereo signal.

- Camera mount stereo shotgun microphone
- Ideal for film, video, and broadcast applications
- Superior frontal directionality and off-axis rejection
- Built-in Mono/Stereo switch
- Frequency Response: 20Hz -20kHz
- Lusterless black soft touch coating
- Includes: SH-10 suspension mount, WSJ-10 Softie windjammer

**CMS-10MS** M/S output only version  
#SACMS10MS..... **\$2195.00**



#SACMS10  
**\$2195<sup>00</sup>**

**COUNTRYMAN**  
**EMW (black)**

#COEMWHWB  
**\$192<sup>50</sup>**



Exceptionally small in size, the EMW is an omnidirectional electret condenser microphone that's ideal for TV broadcast, theater production, presentations, and even instrument recording. Capable of handling high sound pressure levels both directly to and obliquely from the capsule, the EMW is also moisture-resistant, provides very low rubbing noise, and is available with tailored response curves, making it a popular choice for under clothing, normal, and clipped-on instrument use.

- Extremely small, flat lavalier design with hard-wired XLR connection
- Moisture resistant and very low rubbing noise
- Wide response, omnidirectional pattern
- 130dB SPL • Flat 20Hz-20kHz frequency response

**EMWHWBS** *shelved frequency response version*  
#COEMWHWBS.....**\$192.50**

**SONY**  
**ECM-44B**

#SOECM44B  
**\$195<sup>00</sup>**



The Sony ECM-44B is a high-quality, small omnidirectional condenser lavalier microphone. An industry standard, its simple design and ease of use make it the affordable choice for a variety of broadcast and presentation applications.

- Consistent direct and indirect reproduction with low visibility
- Omnidirectional electret condenser microphone
- Complete with in-line battery unit
- Runs up to 5000 hours on single AA battery (not for use with phantom power)
- Holder clip, windscreen, and case included

**ADR44B** *set of (6) black windscreens*  
#SOADR44B.....**\$99.95**

**SHURE**  
**SM11**

#SHSM11CN  
**\$99<sup>95</sup>**



The Shure SM11 is a miniature dynamic lavalier microphone designed for on camera TV broadcasts, stage and specific radio and film applications. Its omnidirectional element is enclosed in a ruggedly-built aluminum case that is lightweight and unobtrusive, with an acoustic response matching most stand and desk-mounted microphones. Its Smooth exterior and recessed grille screen reduces clothing noise and the flexible long-life cable ensures years of reliable use.

- Omnidirectional, dynamic (requires no power) lavalier microphone
- Rugged construction for extended reliability
- Smooth exterior and recessed grille screen reduces noise • XLR connection

**RK203TC** *tie clasp* #SHRK203TC.....**\$12.95**  
**RK200BC** *belt clip* #SHRK200BC.....**\$4.50**

**AUDIO-TECHNICA**  
**AT803b**

#AUAT803B  
**\$139<sup>95</sup>**



Designed to be worn on the clothing of stage and TV performers, the omnidirectional AT803b condenser microphone offers an excellent unobtrusive sound pickup that operates on either phantom or battery power. Additionally, a built-in 80Hz high-pass filter provides easy switching from a flat frequency response to a low-end roll-off, ideal for reducing low frequencies caused by clothing noise.

- Omnidirectional design for clip-on and musical use
- Small, unobtrusive profile
- Operates on both phantom or battery power
- 135dB SPL • 30Hz-20kHz frequency response

**AT835B** *cardioid version* #AUAT835B.....**\$239.95**  
**AT8801** *single phantom power supply* #AUAT8801.....**\$62.95**

**SHURE**  
**SM93**

#SHSM93  
**\$146<sup>50</sup>**



The SM93 is an omnidirectional electret condenser microphone designed for use in TV broadcast, theater, and sound reinforcement applications. It operates over a wide voltage range and provides a full, clean sound that is comparable to larger microphones. The SM93 combines versatile, inconspicuous mounting with a controlled low-frequency roll-off and slight presence boost, making it ideal for body-worn operation.

- Subminiature lavalier design • Small, easy-to-hide mounting hardware • Low distortion, wide dynamic range • Omnidirectional condenser • Wide range phantom powering

**RK354SB** *(2) single bar tie mic clips* #SHRK354SB.....**\$12.95**  
**RK355WS** *set of 4 windscreens* #SHRK355WS.....**\$17.95**



## SONY ECM-77B

An industry standard, the ECM-77B is an omnidirectional electret condenser microphone designed for professional broadcast, sound reinforcement, and recording applications. Its slim profile is easily concealed for performances or broadcast, and with both phantom and battery-powered operation, the versatile ECM-77B becomes an ideal choice for delivering a wide range of functions.

- Omnidirectional pattern with sensitive response
- Ideal for professional performances and broadcast
- XLR connection with multiple connections available
- Powered by either 48V phantom or single AA battery

**ADR77B** set of 6 black metal windscreens #SOADR77B.....**\$94.95**



#SOECM77B  
**\$385<sup>00</sup>**



## SENNHEISER MKE 2 PC

The MKE 2 is a high-quality, sub-miniature clip-on lavalier microphone ideal for a multitude of applications in which other clip-on microphones prove too obtrusive because of their larger size. It fulfills the most stringent sound quality demands and is extremely robust. It is suitable for both speech and instrument miking applications in all areas of live work.

- Omnidirectional, sub-miniature condenser lavalier design
- Well suited for TV, broadcast, and on-stage musical performance
- Capable of handling high volumes during instrument recordings
- 48V phantom powered
- 20Hz-20kHz frequency response

**MZ2** accessory kit #SEMZ2.....**\$39.95**

**MZQ222** tie clips

#SEMZQ222.....**\$19.95**

**MZW2A** steel mesh grill

#SEMZW2A.....**\$16.95**

#SEMKE2PC  
**\$297<sup>50</sup>**

## SANKEN COS-11XBP

The COS-11XBP features an ultra-small capsule design and superior sonic characteristics, often making it the lavalier microphone of choice for TV news and other critical broadcast applications. Available in multiple configurations, this versatile lavalier model is battery-powered and represents an ideal upgrade microphone for many wireless systems.

- Ultra-linear, omni-directional lavalier condenser microphone
- Ultra-miniature capsule, unobtrusive black matte finish
- Moisture- and dirt-resistant capsule
- Unique vertical diaphragm positioning
- "AA" battery power
- 136dB SPL
- 50Hz-20kHz frequency response



#SACOS11XBP  
**\$399<sup>00</sup>**

## AUDIO-TECHNICA AT899



#AUAT899  
**\$199<sup>95</sup>**

Intended for film, theater, and stage applications, the AT899 is a sub-miniature omnidirectional condenser microphone designed to deliver optimal performance. It offers maximum intelligibility and accurate reproduction from all sides of the microphone, while providing additional flexibility of either battery or phantom power operation. Its low-profile design is easily concealed in clothing or hair.

- Omnidirectional, sub-miniature lavalier design
- Even pickup around microphone element
- Operates on both phantom and battery power
- Flat, roll-off switch for reduced rubbing noise
- 138dB SPL
- 20Hz-20kHz frequency response

**AT899A** accessory kit includes Clothing, Viper, and Magnet Clips, Lanyard, Windscreens, Microphone Covers, and Holders #AUAT899AK.....**\$53.50**

## TRAM TR50



#TRTR50BPS  
**\$314<sup>95</sup>**

An industry leader, the TR50 is a professional miniature electret-condenser microphone that provides superior sound quality with minimal coloration from its omni capsule. Its low visibility, wide range of connectors, and multiple color options make the TR50 an ideal choice for film production, broadcast, and stage performance.

- Omnidirectional, miniature condenser lavalier microphone
- Superior sound quality with minimal coloration
- Available with a large range of connectors
- Phantom or battery powered
- Tube style power supply with XLR connector

**TR50BNCMO** same as above without connection and accessories #TRTR50BNCMO.....**\$174.95**

**TR79MLP** TR79 power supply with TA5 connection and positive bias wiring #TRTR79MLP.....**\$167.95**

**ELECTRO-VOICE****RE50B**

Utilizing the concept of a "mic-within-a-mic," the rugged RE-50B is a specially shock-isolated omnidirectional dynamic microphone. It's DynaDamp shock mount and multi-stage integral pop-filter provides an unprecedented degree of isolation from handling, mechanical, and environmental noise, making it a top industry choice for clear, noise-free handheld interview and news-gathering broadcasts.



#ELRE50B  
**\$159<sup>95</sup>**

- Advanced shock-mounting techniques for improved durability and superior low-noise audio reproduction
- Built-in four-stage pop-filter protects from excessive sibilance and wind noise
- Well-isolated transducer seemingly unaffected by environmental extremes
- Omnidirectional pattern for uniform pickup on and off axis
- 80Hz-13kHz frequency response

**SHURE  
VP64A**

#SHVP64A  
**\$77<sup>95</sup>**

The VP64A is an omnidirectional handheld dynamic microphone designed for professional audio and video production. It's Neodymium element, internal rubber isolation, and tailored frequency response deliver high-level, low-noise audio with greater speech clarity and articulation, ideal for indoor/outdoor news gathering and sports broadcast.

- Neodymium magnet for increased output and maximized signal-to-noise ratio
- Tailored frequency response with mid-range presence boost
- Internal rubber shock-mounting for reduced handling noise
- Omnidirectional pattern for uniform pickup on and off axis
- Water-resistant grille for extreme weather conditions
- 50Hz-12kHz frequency response

**BEYERDYNAMIC****M58**

Specifically designed to satisfy the demands of electronic news gathering and electronic field production, the M58 is an omnidirectional dynamic microphone that features a rugged, well-balanced design and sophisticated internal shock mount. It's ideal for providing a high degree of comfort during extended interviews, with minimal handling noise and the ability to withstand the physical punishment of field production.



#BEM58  
**\$239<sup>00</sup>**

- Tailored wide frequency response adds intelligibility and high-end presence
- High-output element with uniform omnidirectional pattern
- Durable construction and internal shockmount reduces handling noise and environmental effect
- Comfortable, weight-balanced, slim-profile design
- 40Hz-20kHz frequency response

**SHURE  
SM63**

#SHSM63  
**\$118<sup>95</sup>**

The SM63 is a high-output, omnidirectional dynamic microphone that delivers both professional performance and looks. Its elegant but rugged design utilizes a patented Shure shock-mount system and VERAFLX grille, improving resistance to drops, rust, corrosion, and moisture. Internally, the high-quality SM63's circuitry is tailored specifically for speech, with a low-frequency roll-off, patented shock mount, and humbucking coil.

- High-output, wide frequency range tailored for speech
- VERAFLX grille resists drops, rust, corrosion, and moisture
- Humbucking coil virtually eliminates strong electromagnetic hum
- 80Hz-20kHz frequency response

**SM63L** same as above with additional 3.5" handle length #SHSM63L **\$132.95**

**SM63LB** same as above with additional 3.5" handle length (black) #SHSM63LB

**\$132.95**

**ELECTRO-VOICE****RE16**

The Electro-Voice RE16 is a dynamic supercardioid microphone designed to meet the most exacting demands of professional broadcast use. Solidly built, the RE16 features a unique blast filter and exclusive non-metallic diaphragm allowing extensive handheld outdoor use without plosives, excessive wind noise, or negative effects due to weather conditions. With superior rejection of unwanted sound and little off-axis coloration, focused, noise-free broadcasts and presentations are now possible both indoors and out.



#ELRE16  
**\$268<sup>00</sup>**

- Dynamic Supercardioid microphone
- Utilizes a "mechanical nesting design," that is, one internal transducer part "nests" within another for greater vibration reduction and durability
- Bass-tilt switch corrects frequency balance
- Humbucking coil and steel outer casing provides 25dB of hum rejection
- 80Hz-15kHz frequency response

## AKG D230

The rugged AKG D230 is a dynamic omnidirectional microphone that easily rejects hum, plosives, and handling noise while effectively reproducing information from all angles, making it ideal for on-location news broadcasts, film production, and sound-effects gathering.



#AKD230  
**\$199<sup>00</sup>**

- Omnidirectional pattern effectively picks up off-axis ambient sounds at lower levels with no coloration
- Very wide frequency response
- All-metal body and humbucking coil, especially effective against magnetic fields such as interview/film lighting
- Internal shockmount and foam lined mesh grill reduces handling noise and pops
- 30Hz-20kHz frequency response



- Ribbon microphone with cardioid pattern and lip-positioning bar
- 60Hz-12kHz frequency response
- Low-frequency roll-off helps eliminate ambient noise and proximity effect
- Removable plastic hygiene shield may be cleaned for reuse, or replaced.

## COLES 4104B

The Coles 4104B is a high-quality ribbon microphone designed to accurately capture speech and commentary in even the noisiest environments. Often used for sports broadcasting, the 4104B is a cardioid pattern microphone with special lip-positioning bar and stainless steel breath shields that provide users an optimal speaking distance—and protection—for achieving warm, accurate signal reproduction with little ambience or proximity effect.

#CO4104B  
**\$859<sup>95</sup>**

## ELECTRO-VOICE 635A

Considered a “Classic” for newsgathering, film production, and radio/video interviews, the dynamic omnidirectional 635A microphone is known to be extremely rugged, noise-free, and capable of withstanding environmental extremes. Practically indestructible with normal use, the 635A provides consistent, reliable operation in the most demanding broadcast/film applications.



- Very low impedance for better noise rejection
- “Classic” news broadcast/interview and video production microphone
- Smooth, natural response
- Effective internal shock absorber and four-stage pop filter for added reliability and pop-free performance
- 80Hz-13kHz frequency response

#EL635A  
**\$109<sup>95</sup>**



- Ideal for interviews and sound-effects gathering
- Natural, uniform omnidirectional pickup with slight high-end presence “lift”
- Durable die-cast case with steel mesh grille
- 50Hz-15kHz frequency response

## AUDIO-TECHNICA AT804

The AT804 is a dynamic omnidirectional microphone designed for use in broadcast interviews, film ambience, and sound-effects gathering. Often used as the “mono” mic in conjunction with a stereo microphone, the AT804 is made of a rugged die-cast case with hardened steel grille and produces a natural, uniform response with a slight high-end “lift” for additional source clarity, particularly well suited for field use environments.

#AUAT804  
**\$89<sup>95</sup>**

## SENNHEISER MD 46

Capable of isolating a source hidden amongst the noise, the Sennheiser MD 46 is a professional dynamic unidirectional microphone designed to deliver high-level handheld field performance. Its well-balanced design, combined with improved sensitivity and cardioid pattern, allow the MD 46 to produce a clean, open sound with slight high-end presence, minus the plosives and proximity effect usually emphasized by unidirectional microphones.



#SEMD46  
**\$174<sup>95</sup>**

- Outstanding interview tool
- Dynamic cardioid pickup pattern improves source isolation while rejecting background noise
- Long, durable handle with excellent balance
- Internal pop filter especially effective against plosives and handling noise
- 40Hz-18kHz frequency response



**SOUND DEVICES****302**#S0302  
**\$1295<sup>00</sup>**

The Sound Devices 302 is a professional, compact, 3-channel audio mixer designed to meet the demands of professional film, ENG / EFP, and broadcast applications. This rugged workhorse provides 3 XLR inputs and stereo XLR outputs (both switchable between mic or line-level signal), 48V, 12V, and 12V-T phantom power, input and output limiting, and a low-cut filter switch on every input. Channels 1 and 2 are stereo-linkable, and a polarity-reverse switch is provided on channel 2 accommodate M-S configurations.

- (3) XLR inputs w/phantom power and (2) XLR outputs
- Individual channel, mono, stereo, M-S to stereo monitoring • Channels 1 & 2 are stereo-linkable, and channel 2 features a polarity switch
- Input and output limiting
- Powered via: (3) AA batteries or external 5-18VDC power source
- Low-cut filter switch available on every input

**SHURE****FP-33**#SHFP33  
**\$1274<sup>95</sup>**

The FP33 is a three input/two output, portable stereo mixer specifically designed for remote audio recording, electronic field production, electronic news gathering, and location film production. It provides three high-quality XLR inputs and stereo XLR output, 48V, and 12V phantom power, flexible signal routing, and panning /level control. The FP-33 has an exceptionally low self-noise and a wide dynamic range, and its rugged plated metal chassis withstands extreme heat and cold.

- The inputs and outputs can be switched between mic and line level signal.
- Professional, backlit analog VU meters (multifunctional)
- (2) 9V batteries provide up to 8 hours of use
- Monitor and tape I/O and either a 1/4" TRS phone or a 3.5mm headphone output
- Built-in tone oscillator
- Isolated two-way talk back

**ROLLS****MX124 ProMix IV**#ROMX124  
**\$179<sup>95</sup>**

The Rolls MX124 ProMix IV is a portable battery-powered 4-channel microphone sub-mixer equipped with a set of phantom-powered XLR inputs. The robust little unit features individual 18V phantom power and low-cut filter switches for each input, allowing for both simultaneous use of both dynamic and condenser microphones and dedicated channel hum and wind noise filtering. The mixer is an excellent low-cost alternative for use in ENG/EFP, video, and sound reinforcement applications.

- Portable 4-channel phantom-powered microphone mixer
- Individual front panel pan and level controls
- Front panel clip and power indicator • (4) XLR inputs, (2) XLR outputs
- 1/4" stereo phone and 1/8" stereo mini headphone or line outputs
- Operates off of dual 9V battery power

**SOUND DEVICES****MixPre**#SOMIXPRE  
**\$665<sup>00</sup>**

The MixPre is a studio-quality, two-channel, portable microphone mixer designed for radio, television, and film production. Its comprehensive features include: pan switches, built-in slate microphone, 1 kHz tone oscillator, and flexible headphone monitoring. The MixPre's compact size,

rugged construction, and high-quality components make it an ideal front end for any field production system.

- (2) XLR mic inputs w/ 48V & 15V phantom power
- Stereo 1/8" tape out & tape return connections
- Monitoring of program audio or external stereo tape return audio
- Built-in limiter w/dual mono or stereo operation • High pass filters: 80Hz or 160Hz
- Powers via: (2) AA batteries or external 5-14VDC

**PSC****DV ProMix 3**#PSDVP3  
**\$470<sup>25</sup>**

The DV PROMIX 3 is a three-channel professional field mixer designed specifically for the DV Cam market. It features three XLR inputs (switchable between microphone and line level signal), switchable 48v phantom power, left/right/ and center position switches on every input channel, and a dedicated 1/8" mini tape return input. The output section features two XLR connectors (line level/ microphone level), and a separate 1/8" mini output.

- Balanced XLR Mic/Line input/output connectors • 48V Phantom power, switchable on each input • Low-Frequency roll-off reduces wind noise
- Bright, sunlight-readable LED meters • Output limiters for camera overload protection • Dedicated Microphone level output jack for use with cameras not equipped with XLR • Reference tone oscillator • Carry case and strap included

**SONY****DMX-P01**

The DMX-P01 is a professional digital field-mixer designed for ENG/EFP applications. This studio-quality portable mixer provides four XLR microphone inputs (switchable between mic and line level signal), 24-bit/96k A/D and D/A converters, AES/EBU and coaxial S/PDIF digital output, and recallable setup memory. Its Flexible analog and digital I/O and routing, 32-bit internal processing, and professional metering make this versatile mixer a top choice for high-resolution field recording.



#SODMXP01  
**\$2695<sup>00</sup>**

- (4) XLR inputs and (2) XLR outputs • 24-bit A/D and D/A converters, 32-bit internal processing • Metering types: VU, BBC-type, DIN-type, NORDIC-type, IEC-type 1 and dBFS
- Supports 48kHz and 96kHz sampling frequencies • Digital limiters on both inputs and outputs, and digital compressors on outputs • AES/EBU digital and S/PDIF digital outputs

**PSC****DV ProMix 6**

The DV ProMix 6 is versatile, cost-effective six-channel ENG & EFP mixer that provides super quiet pre-amplifiers, true dual-camera support, sunlight-readable peak program meters, dedicated individual line outputs, ergonomic fader knobs, a reference tone oscillator, slate microphone

and switchable output levels. Each input includes two-position low-cut filters, three-way channel-assignment switches (pan switches), and handy pre-fade listen switches.

- (6) XLR inputs w/dedicated individual line outputs
- Thoroughly updated, super low-noise pre-amplifiers
- Bright, sunlight-readable peak program meters • Ganging input for combining 2 mixers
- Powered via: (8) AA Alkaline batteries or external power (10-18VDC)
- Comes complete with a custom-made field bag and padded shoulder strap • Weight: 3.5 lbs

#PSDVPM6  
**\$1377<sup>50</sup>**

**SHURE****M367**

The M367 is a six-input, portable microphone mixer specifically designed for professional ENG and EFP



applications. Its exceptional low-noise design makes the M367 ideal for use with digital transmission links and digital video/audio recording media. All input channels and one of the two outputs are switchable between mic and line level signal. Compact and rugged, the M367 is built to withstand the most demanding field production conditions.

- (6) Balanced XLR inputs and (2) XLR outputs • Monitor/headphone out
- 1/4" TRS phone headphone output • ALT I/O: 1/4" phone "Monitor In" jack, Link input/output • Link Input/Output: 1/4" phone "Mix Bus" jack
- Low-cut filter, peak limiter, VU metering
- AC/Battery operation- (2) 9V batteries provide 8 hours of operation

#SHM367  
**\$599<sup>95</sup>**

**PSC****Alpha Mix**

#PSAM  
**\$1866<sup>75</sup>**

The AlphaMix 4 is a four-channel portable field mixer designed for professional ENG/EFP applications. It powers from an NP-1-style battery and is equipped with 4 XLR inputs, low-noise pre-amplifiers, 12T, and 48V phantom power, 3-stage LED peak meters, and 12dB / Octave low-cut filters. The flexible AlphaMix 4 is capable of sending to and receiving signals from 2 cameras simultaneously; each input channel has a dedicated balanced line-level output with pre-fader listen.

- (4) XLR inputs capable of both mic or line level audio operation • Internal NP-1 battery support
- Custom-made peak reading LCD meters
- (4) Hirose style power connectors for powering up to 4 wireless microphone receivers • Built-in slate mic & tone oscillator • Retractable gain trims and pan pots

**AlphaMix Expansion Module** provides an additional 4 input channels #PSAMEM.....**\$565.25**

**SOUND DEVICES****442**

#S0442  
**\$2495<sup>00</sup>**

The 442 is a no-compromise, four-channel portable mixer designed for professional location sound applications. It combines a compact, functional design with features like direct outputs per input, 48V, 12V, and 12V-T phantom power, inputs and output (switchable between mic/line level), peak limiting, and low-cut filters. All of the 442's controls are easily accessible on its three main surfaces, with no hidden controls.

- (4) XLR mic/line inputs
- (3) Separate, isolated, line level outputs
- Every input features a dedicated output via TA3-male connectors
- Two stereo returns: monitor multiple cameras or camera + IFB in headphones
- Channels 1 & 2 can be linked for stereo monitoring or M-S stereo decoding
- Unit is powered via: (4) AA alkaline batteries or external 5-18VDC

## AZDEN FMX-32

#AZFMX32  
**\$329<sup>95</sup>**



The FMX-32 brings you three channels of portable audio mixing in a compact affordable package, with new enhanced circuitry for improved signal-to-noise ratio, and all-metal construction. It runs on 6 AA-sized batteries, and has a switchable input limiter to reduce the possibility of overload distortion. Each of the three balanced XLR mic inputs can provide phantom power to your condenser microphones and can be directly attached to the camera with the supplied hook-and-loop mounting tape.

- (3) mic channels with straightforward design
- Both XLR and stereo mini-jack outputs
- Power On/Off/Low Battery indicator
- 1/4" headphone output and DC input
- 5-segment LED array for signal monitoring

## AZDEN FMX-42

#AZFMX42  
**\$649<sup>95</sup>**



The FMX-42 is a portable 4-channel audio mixer designed for professional and semi-professional field audio applications. It is equipped with (4) XLR microphone inputs with individually switched phantom power and stereo, line level XLR outputs. Additional features include a switchable input limiter, Left / Center / Right Pan switches on all input channels, and enhanced circuitry for improved signal-to-noise ratio.

- (4) XLR microphone inputs
- Dual XLR line level outputs
- Stereo mini-jack output for DV cameras
- Individual level and pan controls
- Built-in limiter & 1k tone generator
- Dual analog meters
- Powers via: (6) AA batteries or optional 12V supply

## WENDT X3



The Wendt X3 is a two-channel field audio mixer designed for ENG/EFP broadcast and remote audio recording. This high performance location mixer features: two XLR inputs, Limiter, PAN switches, external power (9-18V), a slate mic, 1/4" phone jack, mic / line switchable output, switch, and a separate stereo mic out for unbalanced equipment. Its compact, light-weight design has a footprint not much larger than a Sony DAT Walkman.

- 48V phantom, dynamic and 12T power
- 1/4" stereo headphone output
- Stereo LED level indicators
- Low-cut Filters: 140HZ, 20HZ and 100HZ at 12dB per octave
- Reference Tone: 0dBVU 400HZ low distortion sine wave
- Low noise slate mic to right and left outputs
- Mic/Line switchable XLR outputs
- External power (9-18V) or 12 hours of use w/ (6) AA batteries

#WEX3  
**\$1185<sup>00</sup>**

## WENDT X4

Since 1980 Wendt has been providing the industry with high-quality audio mixers, and the X4 continues the legacy with its professional build quality and well-refined features. Each of its 4 XLR inputs has the ability to provide both 48V phantom and 12V T power, and is switchable to accommodate both mic and line level signals. Its large channel fader knobs give immediate visual feedback and are shaped to be manipulated comfortably by feel alone.

- (4) XLR mic/line inputs
- Selectable 140Hz, 20Hz and 100Hz low-cut filtering
- Inputs 1 & 2 may be ganged for stereo operation
- Slate mic and 400Hz reference tone oscillator
- Custom Porta Brace bag with padded strap included



#WEX4VU  
**\$1799<sup>00</sup>**

## WENDT X5

When you need to cover a larger number of microphone inputs for more involved productions, the Wendt X5 is your perfect alternative.

This feature-packed, 5-channel professional field mixer features a sleek design for such a well equipped box, and includes a custom carrying bag with padded shoulder strap. Some of the less immediate setting switches have been placed ingeniously on the bottom of the unit, leaving the side and top control panels feature-packed but uncluttered.

- (5) Mic/Line switchable balanced inputs
- Both +48V and 12T mic power are supported
- Heavy-duty, truly professional build quality
- 5 pin LINK connector cross-links two X5 mixers
- Operates both on external power or AA batteries



#WEX5VU  
**\$2599<sup>95</sup>**



**ROLLS**  
**MX422**

Rolls has designed a four-channel field mixer that includes features usually found on much higher-priced units. It is ideal for DV field production, ENG, and location recording and supports both 1/4" and 1/8" headphone outputs from its front panel. Not only does the MX422 come with a fitted canvas case and external power supply but, having both main and back-up battery compartments means that you will never lose power.

- (4) servo-balanced XLR inputs • Switchable +48V phantom power
- Built-in limiter with variable threshold • Slate mic and 1kHz setup tone
- Calibrated VU meters and battery-test feature



#ROMX422  
**\$499<sup>95</sup>**

**JK AUDIO**  
**Remote Mix 4**



#JKRM4  
**\$1395<sup>00</sup>**

The RemoteMix 4 is a portable field mixer and communications interface that is designed to save setup time by incorporating several powerful functions into one box. Not only does it offer +48 volt phantom power on all of its mic inputs, but it also features a phone line hybrid and keypad, a PBX handset interface and a cell phone interface. Dual 9V compartments allow for battery hot swapping for zero down time, and built-in Bluetooth Technology provides a wireless connection with cell phones, laptops or other portable devices.

- (4) XLR mic inputs with phantom power
- 1/8" stereo I/O for recording or blending in an aux signal
- Built-in Bluetooth Technology
- Cell phone and PBX interface built in
- Phone-line jack with hook switch and ringer LED
- 100-240 VAC power supply included

**KAMESAN**  
**KS-T2000**

The KST-2000 is a well-thought-out and deceptively capable four-channel field mixer in a compact lightweight package. It features solid construction, is easy to use, and offers versatile headphone monitoring and metering control. Input sensitivity controls allow for optimal signal matching, giving each channel fader enough physical range to ride level variations confidently. Low channel crosstalk and output isolation allow the mixer to be configured for multiple feeds as the situation demands.

- Very compact design for less bulk and easy handling • Accepts DC power between 10V and 15V
- (3) XLR mic inputs with 160Hz high-pass filter • 48V or 12V phantom power selectable
- Solid reliable construction throughout • Will run for 5 hours on 4xAA batteries



#KAKST2000  
**\$1490<sup>00</sup>**

**KSPSM12BP** AC power supply for KS-T2000 #KAKSPSM12BP.....**\$200.00**

**KAMESAN**  
**KS-342**

The KS-342 is a four-channel field mixer that blends sleek ergonomic design with solid construction and an intelligent set of expansion options. Independent as well as ganged settings ensure maximum flexibility for stereo and dual mono setups, and the signal passes through switchable compressors before the final output stages. Furthermore, an internal, 96kHz sampled, AES/EBU compliant digital converter delivers the highest-quality output when required.

- Four mic/line inputs with isolated outputs • Backlit, jam-proof, main output level meters
- MS decoding and built-in slate microphone • Easy-to-grip latex knobs on each channel
- (8) AA cells in a "quick change" pack



#KAKS342  
**\$3370<sup>00</sup>**

**BP-1** Optional NP-1 battery clip-on housing #KAKSBH1 .....**\$290.00**

**KSPSM12XLR** AC power supply for KS-342 #KAKSPSM12XLR.....**\$200.00**

**KS-6001** Four-channel sub mixer for KS-342 #KAKS6001.....**\$1,780.00**

**KS-6002** Block of four parametric EQ's and compressors #KAKS6002.....**\$1,280.00**

**SIGN VIDEO**  
**ENG-44**



#SIENG44  
**\$529<sup>00</sup>**

The ENG-44 is a straightforward and cost-effective portable four-channel mixer that offers a host of important features for field applications. Its front panel is uncluttered and easy to navigate and its rugged anodized aluminum chassis is made to stand up to constant use. There is a brightness switch for the audio VU meters to compensate for viewing in direct sunlight and the battery indicator flashes when battery life falls below twenty percent.

- (4) XLR mic/line audio inputs
- Rugged anodized aluminum chassis
- Gang two or more ENG-44 mixers for expanded input
- Slide-out battery compartment for quick changes
- AC adapter included

**M-AUDIO****MICRO TRACK 2496 II**

The Micro Track 2496 II is a second-generation portable Compact Flash audio recorder designed for field professionals to provide enhancements such as extended input gain range, analog input limiting, 48V phantom power, and an even faster file transfer rate via USB 2.0. The unit records in .WAV, .BWF and .MP3 formats to Compact Flash cards or Microdrives, and the files may exceed 2GB in size.



#MAMT2496II  
**\$299<sup>00</sup>**

- 2-channel .WAV, .BWF and .MP3 portable recorder
- Records over 2GB files to Compact Flash and Microdrives
- Dual microphone preamps with 48V phantom power
- Balanced 1/4" TRS mic/line inputs
- 1/8" TRS stereo mic input with 5V power
- Electret condenser microphone included
- Dedicated control buttons, large LCD screen
- AC power supply, USB, or built-in lithium-ion battery power

**EDIROL****R-09**

The R-09 is a professional digital recorder with time-stamp capability, ideal for broadcast and live music-recording applications. It can record stereo audio at 24-bit resolution with either 44.1 or 48kHz sample rates, and files can be exported to a computer via USB. This ultra-portable unit is half the size of the Edirol R-1, and is equipped with a

built-in stereo mic, dedicated input control, intuitive transport buttons and a low-cut filter.

- 24-bit/48kHz (or 44.1kHz) uncompressed recording
- Up to 320kbps MP3 playback and recording
- Records to SD card (64MB card included)
- High-grade stereo condenser microphone built in
- Mic and Line audio inputs; USB I/O
- Easy operation, user-friendly graphic display
- Powers via (2) AA batteries or (2) NiH batteries

#EDR09  
**\$399<sup>00</sup>**

**ZOOM****H4 Handy Recorder**

The H4 Handy Recorder is a palm-sized digital recorder with dual-function 4-track and stereo modes. It is equipped with two built-in condenser microphones in X/Y configuration, two XLR/1/4" combo jacks with phantom power, and a USB port for interfacing with Mac/PC editing systems (unit includes Cubase LE software). The unique 4-track recording turns the H4 into an easy-to-use, 16-bit/44.1 kHz multi-track recorder.

- Dual function 4-track and stereo recording modes
- (2) XLR/1/4" combo input jacks w/ phantom power
- USB port for file transfer to computers
- Onboard studio effects, compression/limiting, and mic modeling
- Back-lit, 128x64 pixel LCD screen
- Powers via: (2) AA batteries
- Includes: AC adapter, windshield cover, USB cable, tripod adapter, and 128MB SD card



#ZOH4  
**\$299<sup>00</sup>**

**ZOOM****H2**

The H2 is a 2-channel, palm-sized portable digital field recorder using readily available SD cards as the storage medium of choice. Ideal for musicians, podcasters, and field journalists, the unit features 4 internal microphone capsules with selectable stereo imaging, 24-bit/96kHz recording resolution, MP3 recording and playback, and a highly-intuitive user interface.

- 2-channel ultra-lightweight portable SD digital field recorder
- Up to 4GB card capacity support
- Selectable 16-, 24-bit WAV, MP3 recording bit rates
- Selectable 44.1, 48, 96kHz sample rates
- 2- and 4-channel recording modes
- Multiple stereo recording patterns with W-X/Y or omnidirectional selection
- 1/8" Mic and Line inputs, headphone output, USB 2.0 port
- AA battery-powered with 4-hr. battery life

#ZOH2  
**\$199<sup>00</sup>**

**MARANTZ****PMD620**

The PMD620 is a miniature handheld 2-channel portable field recorder that records directly to SD flash memory cards in 16- or 24-bit resolution .WAV or .MP3 file formats. Designed with the podcast and broadcast markets in mind, the unit is equipped with a pair of built-in microphones, a surprisingly large and clear LCD screen, and a built-in speaker.

- 2-channel portable digital SD field recorder
- 16-, 24-bit WAV and MP3 file formats
- Mono or stereo recording
- Dual omnidirectional internal microphones
- 1/8" external mic input with 5V phantom power
- Bright, clear, low power-consumption LCD display
- NiMH or AA battery-power with 5 hr. battery life



#MAPMD620  
**\$399<sup>95</sup>**

**NAGRA****Ares-M**

The Ares-M is a lightweight hand-held digital recorder equipped with one gigabyte of internal memory, a built-in stereo microphone, and a miniature USB port. Designed for broadcast applications, it offers instant start-up, voice-operated recording, automatic level control and an internal loudspeaker. This compact, high-quality audio recorder is powered by two AA batteries, offering up to 10 hours of continuous operation.

- Lightweight, ultra-portable audio recorder
- Intuitive menu-driven user interface
- Switchable PCM Mono or Stereo audio recording
- Sampling Rate: 8-48kHz PCM & MPEG
- Bit Rates: 64-384 kb/s
- Built-in microphone or external XLR connection
- Stereo line In/Out and built-in loudspeaker
- Includes: carrying case, plug-on microphone, external mic cable, and USB cable • Frequency response: 30Hz-20kHz

#NAARESM  
**\$850<sup>00</sup>**

**HNB****FlashMic**

The HNB FlashMic is a professional microphone/digital recorder that combines a high-quality Sennheiser omnidirectional condenser capsule with a broadcast-quality, one gigabyte Flash recorder. This durable hand-held recorder is an ideal solution for press and broadcast journalists working in the field and its built-in USB port allows "drag-and-drop" file transfer to Mac or Windows editing workstations in the studio. The FlashMic has an adjustable pre-record buffer, and records in linear 32/48kHz, or MPEG 1 Layer 2 encoded formats.

- Integrated condenser microphone/digital recorder
- High-quality microphone preamplifier w/full manual or automatic gain control
- Maximum record time of over 18 hours
- LCD display with backlight for time, level, and status information
- Switchable high-pass filter, 12dB/octave at 100Hz
- Headphone amplifier with volume control
- (2) AA batteries provide more than 6 hours of continuous power

#HHFM  
**\$999<sup>00</sup>**

**SONY****PCM-D50**

The PCM-D50 is a rugged 2-channel portable field recorder with a lightweight aluminum housing and 4GB of solid state internal flash memory and a Memory Stick slot. The unit, designed for broadcast journalism and sound gathering applications, records 24-bit/96kHz resolution .WAV files, supports .MP3 playback, and features a pair of internal stereo microphones.

- 2-channel portable digital Flash Memory/Memory Stick field recorder • 16-, 24-bit .WAV file recording with selectable sample rates • .MP3 playback
- Internal stereo condenser microphones with selectable X/Y, Wide pickup patterns • Digital pitch control, dual digital filter, low-cut filter, A-B repeat functions
- Ultra-clear LCD screen with peak bar-graph metering
- High-speed USB port for cross-platform computer integration
- NiMH or AA battery-powered operation

#SOPCMD50  
**\$499<sup>95</sup>**

**SONY****PCM-D1**

The PCM-D1 is a high-quality portable recorder designed for a wide variety of mobile recording applications including: broadcast, live sound, house of worship, and theatrical performance. It features 24 bit/96K recording capability, 4GB internal flash memory, removable Memory Stick Pro high-speed storage and a built-in USB 2.0 port for Macintosh and Windows/PC operating systems.

#SOPCMD1  
**\$1849<sup>95</sup>**

- High-quality, 24bit/96kHz mobile digital recorder
- Built-in condenser microphones in an X/Y configuration
- 4GB internal memory or use any size memory stick
- LCD screen with comprehensive recorder status indication and menu selection
- Analog level meters with LED peak overload indicators
- Signal processing functions include: SBM, limiter, and 200Hz high-pass filter • Titanium case
- (4) AA rechargeable batteries & charger (supplied)

**TASCAM****DR-1**

The Tascam DR-1 is a pocket-sized, moderately-priced portable stereo recorder that uses the plentiful SD card as the storage method of choice. The unit is equipped with a unique variable-angle mounting mechanism for the built-in stereo condenser microphones, allowing for reliable recording from almost any angle. The unit supports both WAV and MP3 recording file formats.

- Portable stereo SD recorder with stereo condenser microphone
- 24-bit/44.1/48kHz recording resolution
- Switchable Low-cut, filter, analog AGC and Limiter
- Built-in Tuner, Vocal Cancel and Overdub features
- USB 2.0 computer connector
- 1GB SD card supplied

#TADR1  
**\$299<sup>95</sup>**





**MARANTZ****PMD660**

The PMD660 is professional 2-track hand-held digital recorder ideal for journalist and broadcasters working in the field. This ultra-compact unit records to inexpensive compact flash card or microdrive media, and features two XLR mic inputs, a built-in stereo mic and speaker, and a USB port for interfacing with digital audio editing workstations.

- (2) XLR microphone inputs with 48V phantom power and 20dB pad • 1/8" stereo mini line input and output, 1/8" stereo mini headphone output • Recording Formats: Uncompressed 16-bit linear PCM, Compressed MP2 and MP3 • Includes 64MB compact flash card
- Full onboard cut-copy-paste digital editing
- EDL-style marking system, 99 Virtual-track playlisting
- Power Options: (4) AA batteries or AC adapter (included)

**RC-600** remote option controls record pause, record, marker set, start new track, multi-color LED indicates pause or record status #MARC600 ..... **\$74.95**



#MAPMD660  
**\$499<sup>00</sup>**

**MARANTZ****PMD671**

PMD671 is a professional 24-bit/96 kHz digital recorder designed for high-resolution recording in the field or the studio. Ideal for location professionals, the PMD671 is equipped with two high-quality microphone preamps and loaded with professional features like "Virtual Third Head" for confidence monitoring, Time-Shift Playback, a USB port for easy file transfer to PC, and a built-in condenser microphone.

- 24-bit/96kHz PCM capable
- Two XLR mic connections with 48V phantom power
- Stereo analog RCA line I/O
- Coaxial S/PDIF digital I/O
- Built-in condenser mic
- "Virtual Third Head" for confidence monitoring
- Read-after-write capability
- Built-in monitor speaker
- Optional RC600 wired remote control & NiCd or NiMH batteries

#MAPMD671  
**\$999<sup>00</sup>**

**MARANTZ****CDR310**

The CDR310 is the first truly portable, affordable CD-based field recorder. Whether for documentation, duplication, or archiving, audio CD's promote confidence through their permanence and universality. While digital recording and CD burning have been commonplace for several years, existing hardware has lacked the go-anywhere flexibility users have come to expect in the digital age. Designed to meet the needs of AV integrators, rental firms, corporate board rooms, broadcasters, government agencies, and houses of worship, the CDR310 provides outstanding features that are easy to use.

- On-board hard drive records uncompressed .WAV, .AIFF and .MP3
- Extended material divided over multiple discs automatically
- 10-second rolling buffer is always recording
- Integrated microphone and playback speaker
- (2) XLR phantom power mic & (2) RCA line level inputs



#MACDR310  
**\$699<sup>00</sup>**

**MARANTZ****PMD670**

The PMD670 is a professional 2-track CompactFlash digital recorder designed for the rugged demands of field recording and location sound. It's extremely reliable, has no moving parts, and features two XLR inputs, over 40 assignable quality settings, and a USB port. Once linked to a computer audio editing system via USB, recorded audio files can be transferred from the PMD670 to the computer, ready for import into audio or video editing/production software.

- (2) XLR microphone inputs with 48V phantom power, Limiter and ALC • Coaxial S/PDIF digital I/O, RCA stereo I/O, 1/4" stereo headphone output • Recording Formats: Uncompressed 16-bit linear PCM, Compressed MP2 and MP3 • Auto and manual EDL track marking
- Built-in microphone and speaker, Selectable filter for ambient noise control
- Includes 64MB compact flash card, also compatible with microdrive media
- Power options: (8) AA batteries, AC adapter, or optional RB 1650 rechargeable battery

#MAPMD670  
**\$699<sup>00</sup>**

**EDIROL****R4**

The R-04 is a high-resolution, four-channel, portable 40GB hard disc recorder and wave editor designed for professional mobile recording. With the ability to capture 17 hours of 24-bit/96kHz digital audio and synchronize to Sony digital video cameras using the L-terminal (Lanc) protocol, the R-4 is an ideal solution for both portable music recording applications and ENG/video location sound.

- (4) XLR/phone combo jacks with switchable 48V phantom power
- On-board waveform editing, On-the-fly indexing, Jog Dial with 7 speeds
- High-speed USB 2.0 port, CompactFlash port, Coaxial S/PDIF I/O
- Built-in microphone, speaker, and high-quality effects processor
- Power options: (8) AA batteries or AC adapter (included)
- Windows XP and Mac OS X compatible



#EDR4  
**\$895<sup>00</sup>**

## SOUND DEVICES

## 722

The 722 is a compact two-track hard disc/compact flash field recorder capable of writing and reading uncompressed PCM audio at 16 or 24-bits with sampling rates between 32kHz and 192kHz. Featuring two top-quality high-bandwidth preamps, flexible metering and powering options, and digital I/O, the 722 is a high-resolution alternative to DAT for today's location sound professional.

- (2) XLR microphone preamps with phantom, limiters, and high-pass filters
- Channels 3 and 4 line-level inputs on TA3 connectors • AES3(XLR) or AES3id(BNC) digital inputs and AES3ib outputs • Records to internal 40GB hard drive or removable compact flash
- FireWire port for high-speed data transfer to computers
- Aluminum and stainless-steel chassis
- Powers via: Sony-compatible L- or M-type lithium-ion camcorder batteries or external DC
- Windows and Mac OS compatible

#S0722  
\$2495<sup>00</sup>EDIROL  
R-4 Pro

The R-4 is a high-resolution, four-channel portable 80GB hard disc recorder and wave editor that can act as a S/MPTe time code master or slave to incoming code video cameras or VTR's. Designed for both portable music recording applications and ENG/video location sound, the R-4 Pro provides 4 XLR/Phone combo with switchable phantom power, a high-speed USB 2.0 port and powerful onboard waveform editing.

- (4) XLR inputs with switchable 48V phantom power • 24-bit/96-kHz Linear Recording
- SMPTE time code I/O on BNC connectors • Onboard waveform editing • & AES/EBU I/O
- Built-in microphone, speakers, and effects processor • Powers via: (8) AA batteries or 4-pin XLR type power input • Includes: USB cable, XLR 4-pin conversion cable, and soft carrying case

#EDR4PRO  
\$1999<sup>00</sup>

## SOUND DEVICES

## 702

The 702 is a portable compact flash audio recorder of uncompromising quality. Capable of recording two channels of uncompressed audio up to 192kHz resolution, it's also easy to operate. When connected to a computer via FireWire, it appears as an external drive, and files can be dragged off. Ideal for professional production or anyone who wants a solid and dependable recording apparatus.

- Stellar audio path with (2) XLR low noise, wide frequency response preamps
- Lightweight aluminum and stainless steel compact chassis
- Included removable Li-on rechargeable battery and worldwide power supply
- Phantom power, limiters, and high pass filters
- Direct sunlight-viewable LED metering
- .MP3 audio playback supported

#S0702  
\$1875<sup>00</sup>FOSTEX  
FR-2LE

The FR2-LE records Broadcast Wave Format (.BWF) or .MP3 files to affordable type II

CompactFlash or Microdrive cards, at up to 24-bit/96kHz resolution. It features powerful on-board editing functions and a USB 2.0 port for high-speed file transfers to PC editing suites. Time stamping of .wav or MP3 files is provided; allowing for easy time alignment of audio files in Audio/Video software workstations.

- (2) Mic/Line inputs w/phantom on Neutrik combo jacks • Stereo RCA analog outputs & 1/8" stereo headphone output • Read After Write (.RAW) confidence monitoring recorder • Time stamps .wav or .MP3 files • USB 2.0 for high-speed file transfer
- ALC (Off/ALC/limiter) • Powers via: (4) x AA Batteries or 12V DC input
- Includes wired remote controller

#FOFR2LE  
\$599<sup>00</sup>ZAXCOM  
ZFR100

The ZFR100 is a miniature broadcast-quality recorder that can record up to 12 track-hours of audio directly to a 2GB flash memory card. Designed to simplify audio syncing and processing during post-production, the ZFR100 includes a full-

featured time code reader/generator that stamps the time code directly on to broadcast .wav or .MP3 files. It can receive time code directly from a video camera with an option to record only when the camera is rolling.

- Ultra-compact digital recorder with time code
- Ideal for ENG and Broadcast applications
- Lightweight, weighs only 4 oz
- Includes PC and Macintosh software
- Powers up to 24 hours with (2) AA batteries
- Optional 8- 16VDC power input also available

#ZAZFR100  
\$995<sup>00</sup>

## SOUND DEVICES

## 702T

#S0702T  
**\$2495<sup>00</sup>**

The 702T is a high-resolution, two-track CompactFlash recorder designed specifically for dual-system film and video productions where audio needs to be master. It provides ultra-stable Ambient time code functionality, AES/EBU & S/PDIF I/O and a FireWire port for high-speed data transfer to computers. This portable unit's flexible powering options include standard Lithium-ion camcorder batteries or external 10–18VDC.

- 24-bit or 16-bit (with or without dither)
- Sampling rates selectable between 32kHz-192kHz
- (2) mic preamps with phantom, limiters, and high-pass filters
- Full-function, ultra-stable Ambient time code
- AES/EBU & S/PDIF digital I/O
- FireWire port for high-speed data transfer to computers
- Removable Lithium-ion rechargeable battery
- Durable aluminum & stainless-steel chassis

**702** Version without time code #S0702 .....**\$1875.00**

## SOUND DEVICES

## 744T

#S0744T  
**\$4095<sup>00</sup>**

The 744T is a compact four-track hard disc/compact flash field recorder with time code, capable of writing and reading uncompressed PCM audio at 16 or 24-bits with sampling rates between 32kHz and 192kHz.

Designed with the location sound professional in mind, the 744T features full timecode implementation, flexible metering and powering, top-quality mic preamps, and is built to Sound Devices' exacting standards for reliable performance and exceptional durability.

- Ultra-stable Ambient timecode circuitry, tunable to <0.2 PPM accuracy
- (2) XLR microphone preamps with phantom, limiters, and high-pass filters
- Channel 3 and 4 line-level inputs on TA3 connectors
- AES3(XLR) or AES3id(BNC) digital inputs and AES3ib outputs
- Records to internal 40GB hard drive or removable compactflash
- FireWire port for high-speed data transfer to computers
- Powers via: Sony-compatible L-or M-type lithium-ion camcorder batteries or external DC
- Windows and Mac OS compatible

## EDIROL

## R-44

#EDR44  
**\$895<sup>00</sup>**

The R-44 is a robust, high-resolution 4-channel solid state field recorder using SD or high-capacity SDHC cards as storage media. The unit is equipped to handle 4 simultaneous recording channels of uncompressed audio at up to 24-bit/192kHz resolutions, and includes on-board effects processing such as EQ, limiting, a low-cut filter, an enhancer and de-esser. This recorder is a worthy alternative for journalists, musicians, and videographers working on location.

- 4-channel hi-res SD field recorder with built-in stereo microphones
- WAV/BWF file formats, switchable 16-/24-bit recording with selectable SRC
- Large bright LED display, internal waveform editing
- (4) XLR/1/4" combo input jacks with 48V phantom power
- (4) RCA outputs
- SDHC cards storage media with up to 8GB capacities



## TASCAM

## HD-P2

#TAHDP2  
**\$999<sup>00</sup>**

The HD-P2 is a 24-bit/192kHz Compact Flash recorder designed for broadcast and location sound applications. It features SMPTE timecode input, professional connectivity, a large, angled LCD, and a FireWire port for fast data transfers to computer editing systems.

A video clock input allows frame edge resolve to a central blackburst source or use as a lock-and-release timecode slave.

- (2) XLR Mic Inputs w/phantom power & analog peak limiter
- Unbalanced stereo RCA I/O
- FireWire interface for data transfer
- Built-In mono mic, speaker and headphone output
- XLR SMPTE Input & BNC Video Clock Input
- Supports Pull-up and Pull-down sample rates
- S/PDIF digital I/O
- PS/2 keyboard input

## FOSTEX

## DV824

#FODV824  
**\$5995<sup>00</sup>**

The DV824 is an 8-track DVD multitrack recorder/player that can be powered via AC or DC current, making it ideal for on-cart location applications. It provides 8 channels of XLR analog I/O, 8 channels of AES/EBU digital I/O, a high-speed 10/100Base-T Ethernet port, and SMPTE timecode in and out on BNC connectors. The DV824's high-definition recording engine offers multitrack recording in six audio formats, with up to 24-bit/96kHz resolution.

- 8-Track Recording/ Playback on DVD-RAM media
- (8) XLR analog inputs and outputs
- (8) AES/EBU digital inputs and outputs
- SMPTE/EBU Time Code in and out
- Front-panel USB keyboard input
- Flexible AC or DC (for location use) power operation
- Large LED time display & 18-bar level meters



**MARANTZ****CDR420**

The CDR420 is a professional field recorder that combines a flexible hard disc recorder with an onboard CD recorder that burns both standard Red-Book audio format and CD-ROM data discs. It features a built-in condenser microphone and speaker, dual XLR Mic/Line inputs and coaxial S/PDIF digital I/O. Onboard editing permits cut, copy, paste, insert silence, and split track; a USB 2.0 port allows users to upload files easily to a digital audio workstation.



#MACDR420  
**\$1199<sup>00</sup>**

- Record to 20GB hard disc in 44.1kHz mono or stereo as .WAV or .MP3
- (2) XLR Mic/Line inputs w/ +48v phantom power • (2) RCA inputs • 20GB hard drive
- Built-in microphone and speaker • Standard PS/2 keyboard input for naming files
- Includes: AC adapter and dual RCA cable • Optional lead acid battery (RPS420)

**OLYMPUS****LS-10**

The LS-10 is a miniature PCM portable field recorder that stores data to either its 2GB internal memory, or to SD cards with up to 8GB capacities. The unit is 24-bit/96kHz-capable, and records in WMA, MP3 and WAV file formats. The unit features a sensitive, low-noise built-in stereo microphone and integrated stereo playback speakers.

#OLLS10  
**\$399<sup>00</sup>**

- Palm-sized portable field recorder with 24-bit/96kHz resolution
- 2GB internal memory or SD card storage to 8GB
- WMA, MP3 and WAVE file formats, USB port
- 12-hr. recording time with 2 "AA" batteries
- Ultra-lightweight 5 oz. aluminum chassis
- Includes strap, carrying case, windscreen, USB cable, Cubase LE4 DVD-ROM

**SONY****MZ-M200**

The MZ-M200 is a portable minidisc recorder that's capable of recording in HiMD mode and also in standard MD mode, so it's compatible with older formats. Recorded files can be transferred to a Mac or PC via its USB 2.0 port and included Sony software. The low cost, high-capacity HiMD discs make this an excellent recorder for students, musicians, and journalists.



#SOMZM200  
**\$399<sup>95</sup>**

- Included rechargeable battery charges via USB or AC adaptor
- Stereo microphone, earphones, and AC adaptor, 1GB HiMD disc included
- Digital pitch control • Mic/line input • 11-segment recording meter display
- Mac and Windows compatible

**KORG****MR-1000**

The MR-1000 is a lightweight 2-channel, 1-bit professional portable hard-disk recorder with an internal 40GB internal drive.



#KOMR1000  
**\$1199<sup>00</sup>**

The unit supports multiple bit rates and file formats as well, accommodating most current field recording requirements, and features a large, bright LCD screen, flexible audio connectivity, and a USB 2.0 port for direct interfacing with a PC or Mac.

- 2-channel portable digital field recorder
- 1-bit DSDIFF, .DSF and .WSD file support
- 16-, 24-bit .WAV, .MP3 and .BWF file support
- 1-bit sample frequencies include 2.8224MHz, 5.6448MHz
- 16-, 24-bit SRC from 44.1 to 192kHz
- (2) XLR/1/4" TRS Combo inputs
- (2) Combo and (2) RCA phono, Headphone, USB 2.0 outputs
- AC and AA battery-powered, AudioGate conversion software

**IKEY-AUDIO****I-Key Plus**

#IKIKEYP  
**\$129<sup>95</sup>**

The I-Key Plus is a Portable USB Recorder designed to record directly to any external USB storage device, including the Apple iPod. Digital audio is recorded in uncompressed .WAV or .MP3 format (with selectable bit rate, up to 256kbps). It is equipped with a line/phono/mic input, a headphone jack for real-time monitoring, a built-in phono preamp, and a 6-bar VU meter with peak hold and overload indicator.

- Records audio to uncompressed .WAV or .MP3 formats
- 1/8" line/phono/mic input, stereo RCA inputs
- 1/8" (3.5mm) headphone monitor output
- Built-in phono preamp
- Compatible with USB storage devices, including the iPod
- LED Indicator shows memory remaining on target drive
- Requires (4) AA rechargeable batteries (not included)

**SAMSON**  
**UHF Micro 32**

The Micro 32 is a versatile frequency-selectable diversity wireless microphone system offering a relatively inexpensive sound solution in a portable package. There are 32 user selectable frequencies and diversity circuitry ensures optimum RF performance. Surface Acoustic Wave filters in the receiver focus exclusively on the incoming signal to maximize reception and transmission quality. PLL-synthesized VCO circuitry in the transmitters reduces RF interference from spurious emissions in multi-user applications.

- 32-channel camera mount UHF lavalier system
- Dual-function battery/RF level LED meter
- MT-350 omnidirectional lav microphone
- Locking mini-XLR to XLR output cable
- Special carry case included

**UM32HHQ7** with Samson Q7 handheld transmitter #SAUM32HHQ7.....**\$389.95**  
**SWAX3** replacement mini-XLR to XLR male output cable #SAX3.....**\$24.95**

#SAUM32L350  
**\$349.95**



**AZDEN**  
**320 Series UHF Wireless Systems**

The 320 Series is a group of camera-mountable portable UHF wireless systems built around the 320UPR dual receiver. The 320 Series Systems are packaged with two wireless transmitters for simultaneous operation. There are 240 selectable frequencies and separate 1/8" outputs available for each channel, along with dual multi-function LCD displays, a removable shoemount, and a pair of flexible, high-gain antennas.

- Dual-channel, dual-transmitter UHF wireless systems
- 2 independent channels with 240 selectable frequencies per channel
- Separate outputs per channel, dual-plug XLR and stereo-mini cables included
- Multi-function LCD readout

**320ULH** with 320UPR receiver, 30HT handheld transmitter, 30BT bodypack transmitter, EX503 lavalier microphone #AZ320ULH.....**CALL**  
**320ULX** with 320UPR receiver, 30XT plug-in transmitter, 30BT bodypack transmitter, EX503 lavalier microphone #AZ320ULX.....**\$799.95**  
**320ULT** with 320UPR receiver, (2) 30BT bodypack transmitters, (2) EX503 lavalier microphones #AZ320ULT.....**\$799.95**  
**320UPR** 2-channel wireless receiver #AZ320UPR.....**\$499.95**

**SAMSON**  
**UM1/Airline Series Combo System**

The two most attractive features of the UM1/Airline Combo System are the extremely small size of the AL1 clip-on transmitter and the fact that with the included AX1 plug-in transmitter you have several miking options available. This single-channel UHF system features the UM1 diversity receiver, which connects to your camera with the included balanced XLR output cable. The AL1 is a transmitter that features its own built-in mic, but becomes even more powerful when used with one of the available optional lavaliers.

- Combo single channel UHF wireless system
- Includes clip-on and plug-in style transmitters
- Headphone output with level control
- Carry case protects all components

**MT-350** optional omnidirectional lavalier microphone #SAMT350MP.....**\$69.95**  
**AT-831** optional cardioid lavalier microphone #SAAT831MP.....**\$119.95**

#SAUMCU1  
**\$554.95**



**AZDEN**  
**100LT**

The 100LT wireless lavalier system offers 63 user-selectable UHF channels with a smaller receiver that is ideal for today's compact digital cameras. It comes complete with an EX-503 omnidirectional microphone and both transmitter and receiver run from 6 to 8 hours on a single 9V battery each. With the optional XLR output cable and included camera mount adapter, this unit is ready to be used in any situation requiring a lightweight, compact and affordable multi-channel wireless lavalier.

- On-camera wireless UHF lavalier system
- 63 user-selectable frequencies
- 1/8" mini and optional XLR output cables
- Hot-shoe mount included for receiver

**100HT** handheld version of above #AZ100HT.....**\$348.95**  
**100LTH** combo version includes handheld and lavalier transmitters #AZ100LTH.....**\$489.95**

#AZ100LT  
**\$339.95**

**SONY**

**UWP Portable Wireless Series**

The line of UWP portable wireless systems from Sony has been upgraded to offer many desired features. Its chassis now has a rugged metal construction, and a mic/line input been added to the transmitter. The lavalier microphone is smaller and its sound quality, as well as the handheld mic's has been improved. The redesigned UWP receivers feature a back-lit display and the ability to scan the available frequencies for a quick and easy set-up process. These professional wireless components are ideal for ENG and field production applications.

- UWP-V130** Lav mic, bodypack transmitter, receiver in channel 30/32 #SOUWV13032.....**\$499.00**
- UWP-V142** Lav mic, bodypack transmitter, receiver in channel 42/44 #SOUWV14244.....**\$499.00**
- UWP-V630** Lav mic, bodypack and plug-on transmitter ENG kit in channel 30/32 #SOUWV63032..**\$699.00**
- UWP-V642** Lav mic, bodypack and plug-on transmitter ENG kit in channel 42/44 #SOUWV64244..**\$699.00**



**SENNHEISER**  
**EW100ENG2A**

#SEEW100ENG2\*  
**\$699<sup>00</sup>**

Providing 1,440 selectable UHF channels, the durable full-featured Sennheiser EW100ENG2 wireless microphone system is ideal for on-location film, broadcast, and event videography. Popular among many professionals for its rugged construction, intuitive programmable user menu, large backlit displays, and versatile high-quality audio performance, the EW100 "combo" system is the perfect complement for completing any field-recorder's toolbox.

Combo system includes: SK100G2 Bodypack Transmitter, ME2 lavalier mic, EK100G2 Receiver, and SKP100G2 Plug-On Transmitter.

- 1,440 Tunable UHF frequencies with 4 switchable preset channels
- Up to 490 ft. operating distance
- Variable sensitivity and output power settings
- 4 switchable preset channels

- POP-1** belt/carry case for SKP100 plug-on transmitter #SEPOP1.....**\$47.95**
- ZH100-ANT** pin-style, lavalier clothing clip #SEZH100B.....**\$12.50**
- CL-100** 1/8"-M to XLR-M cable for EK100 receiver #SECL100.....**\$46.95**

**SENNHEISER**  
**EW500G2A**

#SEEW500ENG2\*  
**\$1089<sup>95</sup>**

The EW 500 Series components are the next step up from Sennheiser's extremely successful and dependable 100 series. The 500 features the same metal construction, wide frequency range and easy-to-read backlit display that made the 100 such a hit, and adds some new welcome features. The EK 500 G2 receiver features independent adjustable audio level for both line and headphone outputs, and the system itself offers 20 user-storable preset frequencies. The SKP 500 G2 plug-on transmitter also provides 48V phantom power allowing the use of condenser mics in your setup.

- Combo system with SK500 transmitter, EK500 receiver and SKP500 plug-on transmitter
- 1440 selectable frequencies with 20 presets
- Includes 1/8" inch mini and XLR output cables
- High RF output power for extended range



**LECTROSONICS**  
**100 Series**

#LE100LMK121Q  
**CALL** for Price

Designed for on-location situations where reliable performance and operation are of the utmost importance, the Lectrosonics 100 Series Wireless System provides a superior sound with up to 256 channels of selectable UHF frequencies. The complete system is equipped with the UCR100 camera-mountable receiver, LM digital hybrid bodypack transmitter and M150 lavalier microphone and features dual-band companding (a process that separates audio signals into high- and low-frequency bands for better noise reduction, lower distortion, resulting in more accurate sound quality).



- 256 user-selectable UHF channels
- LM transmitter features Digital Wireless Hybrid Technology which combines a 24-bit digital audio chain with an FM radio link
- Series 200 and 400 compatible

- MC100XLR** 3.5mm mono plug to unbalanced male XLR with inline attenuator #LEMC100XLR.....**\$22.50**
- MC100TRS** 3.5mm TRS (stereo) straight plug to 3.5mm TRS (stereo) right angle plug #LEMC100TRS...**\$6.95**
- Tram TR-79** power supply w/XLR output for M150 lavalier microphone #TRTR79MLP.....**\$167.95**



**LECTROSONICS**

**SR Dual-Channel Slot-Mount Receiver**

#LESR\*  
**\$1768<sup>00</sup>**

The SR is a ruggedly-built camera-mountable 2-channel UHF diversity wireless receiver featuring two independent channels, designed to fit into the standard video slots found on most pro cameras. The two Digital Hybrid Wireless receivers housed in the casing offer a selection of 256 frequencies from one of 9 frequency blocks assigned to the unit, which users may choose for compatibility with their location. The unit provides unmatched clarity, durability, and reliability of transmission.

- Dual-channel UHF slot-mount wireless receiver for professional cameras
- 2 independent channels for separate or internally mixed input feeds
- 256 frequencies available from pre-assigned frequency block
- Splash-resistant sealed-membrane controls and LCD
- Two diversity operating modes
- Compatible with variety of Lectrosonics and other manufacturer's systems
- Exceptional 30Hz-20kHz frequency response, 107dB S/N before limiting



**AZDEN  
500LTS**

#AZ500LTS  
**\$639<sup>95</sup>**

The Azden 500LTS camera-mountable lavalier microphone system provides true diversity operation and up to 63 user-selectable UHF frequencies ideally suited for professional broadcast applications. Combining the lightweight, durably constructed 51BT belt/bodypack transmitter, ECM-44H lavalier microphone and full featured 500UDR diversity receiver, this well-designed wireless system is an exceptional value for ENG, special events, and presentations.

- 63 user-selectable UHF channels
- UHF Diversity for RF interference free operation and minimal dropout
- Omnidirectional electret condenser lavalier microphone
- 1/8" mini-jack connection for headphone monitoring
- Transmitter requires one 9V battery
- Receiver requires (6) AA batteries or external 12V DC power supply

<b>51XT</b> plug-on transmitter w/phantom power #AZ51XT .....	<b>\$199.95</b>
<b>51HT</b> omnidirectional handheld transmitter/microphone #AZ51HT .....	<b>\$179.95</b>
<b>EPS12PC</b> external 12V battery power supply #AZEPS12PC .....	<b>\$109.95</b>

**AZDEN  
300LT**

#AZ300LT  
**\$469<sup>95</sup>**

The 300LT portable wireless lavalier microphone system offers 240 selectable UHF frequencies and a compact receiver ideal for miniature video camera-mounting. The system is complete with an Ex-503 omnidirectional lavalier microphone and a shoe mount, while the receiver and transmitter will operate for 8 hours on 2 AA batteries, and are equipped with LCD displays.

- Camera-mountable wireless UHF lavalier system
- 240 selectable frequencies
- 1/8" mini receiver output
- Headphone monitoring direct from receiver

<b>30XT</b> optional plug-in transmitter #AZ30XT .....	<b>\$199.95</b>
<b>EX505U</b> optional unidirectional microphone #AZEX505U .....	<b>\$39.95</b>



**LECTROSONICS  
UCR401**

#LE40121  
**CALL**



The UCR401 is a high-performance compact UHF wireless microphone receiver for mobile applications such as ENG and film production. The compact size, option for battery or external powering, and rugged attached antennas are ideal for video camera-mounted use. Unique DSP algorithms in the design provide full compatibility with all Lectrosonics 400 Series Digital Hybrid Wireless™ transmitters and a variety of analog transmitters from Lectrosonics and several other top manufacturers.

- Digital Hybrid UHF camera-mountable receiver
- 256 frequencies across a 25.6 MHz bandwidth
- Compatible with analog transmitters
- Spectrum analyzer displays RF activity to quickly identify clear frequencies
- Balanced XLR output

**LECTROSONICS**

**400 Series**

The Lectrosonics 400 Series UHF Wireless Microphone System combines digital hybrid technology and powerful DSP with true diversity reception and nearly indestructible components to form a great-sounding, virtually noise-free RF system. Ideal for broadcast, "reality TV" productions, nature, and documentary film applications, this frequency-agile lightweight system includes the UCR411 camera-mountable receiver, MM400A water resistant, digital hybrid belt-pack transmitter, and the M150 omnidirectional lavalier microphone.

- 256 user-selectable UHF channels
- SmartSquelch, SmartDiversity, SmartNR noise reduction circuitry
- Series 100 and 200 compatible
- MM400A transmitter features Digital Wireless Hybrid Technology which combines a 24-bit digital audio chain with an FM radio link providing outstanding audio quality and extended operating range

**UH400** Digital Hybrid plug-in transmitter w/phantom power #LEUH40021 ..... **Call**

#LE411AMM21  
**CALL**  
for Price



**LECTROSONICS**

**SM**

Lectrosonics sets a new standard for size, power, reliability, and functionality with the ultra-miniature SM transmitter. Not much bigger than two AA batteries, the 100mW SM packs all user controls onto an easy-to-operate control panel that includes an LCD and four membrane switches. It can also be set to work with all of Lectrosonics Digital Hybrid Wireless receivers, Lectrosonics 200-Series and 100-Series analog products, Lectrosonics IFB systems, and even analog receivers from some other manufacturers.



- Super-Miniature Digital Hybrid UHF belt pack transmitter
- 256 synthesized UHF frequencies
- LCD and membrane switch control panel
- Wide input dynamic range

**RM** remote control for SM series

#LERMQ ..... **CALL**

**SMBCUP** optional belt clip points antenna up

#LESMBUCUP ..... **CALL**

**SMBCDN** optional belt clip points antenna down

#LESMBCDN ..... **CALL**

#LESM21  
**CALL**

**LECTROSONICS**

**VR Field**

The VR Field is a portable wireless UHF field receiver with 256 selectable frequencies, designed for use with the Lectrosonics Venue wireless system to deliver multi-transmitter operation from a single receiver master base. The unit houses up to 6 VRT or VRS receiver modules with compatible frequency blocks, enabling simultaneous 6-transmitter operation. The VR Field uses noiseless, compander-free Digital Hybrid Technology for crystal-clear reception.

- Multi-receiver UHF field housing unit
- 256 selectable frequencies
- (6) XLR outputs
- 12V NP-1 battery operation



**VRS** optional plug-in receiver module #LEVRS27 ..... **CALL**

**VRT** optional tracking receiver module #LEVRT28 ..... **CALL**

#LEVRF2728  
**CALL**

**LECTROSONICS**

**UH400A**

The UH400A is a digital hybrid synthesized UHF plug-on transmitter compatible with all receivers in the Lectrosonics 400-, 200-, and 100-Series product groups. The DSP-based design allows the transmitter to operate in its native Digital Hybrid Wireless mode, or in several alternate modes that are compatible with analog receivers. A unique multi-voltage phantom power feature allows the transmitter to be used with any XLR microphone, including high-current condenser types, expanding its usefulness in high-end applications, such as motion picture production.



- Digital Hybrid plug-on transmitter
- Selectable 5, 15, and +48V phantom power
- 256 synthesized UHF frequencies
- 100mW output power
- Rugged machined aluminum housing

#LEUH40021  
**CALL**

## SONY

## WRR-861B

The WRR-861B is a single-channel version of the WRR-862B dual receiver that features the same solid construction and reliable performance in a compact package. It works with any of the WL-800 family of components in the same frequency group, giving you an extremely wide variety of transmitters to choose from. Diversity operation ensures the strongest signal possible, and the built-in battery alarm starts flashing approximately one hour before the battery is exhausted.

- Compact 2-channel, Dual Diversity receiver
- 188 selectable frequencies
- Internal (4AA batteries) or external powering
- Includes XLR output cable
- Power from AA battery or DC from camcorder
- Separate monitor output with level control
- Rugged, die-cast magnesium construction
- LED and full-status LCD indication
- Approx. 8 hours of operation w/4 AA batteries
- Low battery alarm warns against power loss

#SOWRR861B\*  
**\$1420<sup>00</sup>**

## SONY

## WRT-822B

The WRT-822B UHF synthesized bodypack transmitter, with a feature set that pairs well with the other members of the WL-800 family. Its magnesium alloy body is built for repeated use and the 20mW RF output has adequate power for moderate distances, but powers low enough to avoid IM-related problems in multi-channel systems. It will transmit a battery alarm to compatible tuners allowing easy remote monitoring of battery status. The locking Bayonet 4-Pin connector supports a wide selection of available lavalier microphones.

- UHF belt-pack transmitter with PLL technology
- 188 selectable frequencies
- 8 hours continuous operation with 2AA batteries
- Easy-to-read LCD display

**WRT822BM44** WRT-822B with Sony ECM-44 lavalier microphone #SOWRT822BM44 .....**\$884.95****WRT822BM77** WRT-822B with Sony ECM-77 lavalier microphone #SOWRT822BM77 .....**\$1034.95**#SOWRT822B\*  
**\$639<sup>95</sup>**

## SONY

## WRT-8B

The WRT-8B Bodypack transmitter is the latest addition to the extensive range of Sony UHF synthesized wireless microphone systems. It is extremely compact and lightweight, for use in fast-moving TV and theater productions. Inside its tough, die-cast magnesium body is a highly stable, low-noise transmitter that provides superb audio quality. It can operate for up to 13 hours on two AA batteries, and features switchable AF input (Mic/Line) and RF output levels (10mW/50mW). Compatible with the WL-800 family of products.

- Very compact UHF belt-pack transmitter with PLL technology
- 188 selectable frequencies
- Easy-to-read LCD screen with LED indicators
- Accommodates Sony microphones fitted with an SMC9-4P connector

**ECM44BC** omnidirectional electret condenser #SOECM44BC .....**\$99.95****ECM77BC** compact omnidirectional electret condenser #SOECM77BC .....**\$259.95****ECM88BC** premium, low-noise omnidirectional electret condenser #SOECM88BC .....**\$339.95**#SOWRT8B\*  
**\$1850<sup>00</sup>**

## SONY

## WRT-8P

When you combine the WRT-8P Plug-on transmitter with your choice of handheld ENG microphone, you gain a high performing interview mic/transmitter package with excellent sound quality. The WRT-8P offers switchable power output and operates for up to 4 hours on a 9-volt battery when set to 50mW RF output, or 2.5 hours when set to 250mW RF output. In addition, the WRT-8P also accepts line-level audio signals, making it ideal for a wide range of wireless audio production applications. Compatible with all WL-800 series of products.

- Plug-on transmitter featuring PLL technology
- 250mW high RF output power for stable transmission
- Selectable RF output power 250mW/50mW
- Selectable mic/line level input
- Battery alarm function transmitted to tuner
- 188 selectable frequencies
- Stable, high-output transmission
- 4 hours of continuous operation at 50mW

#SOWRT8P\*  
**\$795<sup>00</sup>**



**SONY**  
**WRR-862B**

#SOWRR862B\*  
**\$3500<sup>00</sup>**

The WRR-862B66/68 is a UHF-synthesized Dual Diversity Tuner that allows for the use of two WL-800 series wireless microphones simultaneously. This diversity tuner has been introduced to meet the demand for two-channel reception in ENG and EFP applications. Two space-diversity receiver modules are built in to its rugged, compact, and extremely lightweight body, made from die-cast magnesium. This makes the WRR-862B especially suitable for mounting onto professional camcorders. It may be used as a redundant single-channel system for critical situations.

- Compact 2-channel, Dual Diversity receiver
- 188 selectable frequencies per receiver
- Headphone monitor output with adjustable level control
- Designed to mount onto most Sony Pro cameras
- Approx. 5 hrs. of operation on 4 AA batteries
- LED battery, antenna, and RF indicators
- LCD for group, channel, frequency and squelch settings
- Includes 2 XLR terminated output cables
- Rugged, die-cast magnesium construction
- Power from AA battery or DC from camcorder



**AZDEN**  
**200ULT**

#AZ200ULT  
**\$587<sup>50</sup>**

There are countless situations where the ability to mic two subjects simultaneously would be the perfect alternative for capturing the best audio quality possible. The 200ULT provides you with the ability to use two wireless lavalier microphone transmitters with a single receiver in a package that will interface with any 1/8" inch mini or XLR input camera. The system has a rated run time of better than 8 hours and the receiver comes with its own hot-shoe mount for convenient and secure camera mounting.

- Dual-channel, on-camera wireless lavalier system
- 63 selectable UHF frequencies
- (2) 10BT bodypack transmitters with EX-503 lavaliers
- 200UPR receiver outputs to 1/8" mini and dual XLR

**200ULX** includes (1) lavalier belt-pack transmitter and (1) plug-on transmitter #AZ200ULX ..... **\$599.95**  
**200ULH** includes (1) lavalier belt-pack transmitter and (1) handheld transmitter #AZ200ULH ..... **\$599.95**

**AUDIO-TECHNICA**  
**1800 Series**

Since its introduction, the Audio Technica U100 single-channel, on-camera wireless system has proven to be a well accepted and dependable performer. With more and more videographers requesting the ability to use two wireless microphones without the cumbersome bulk of two receivers, AT has introduced the 1800 series of UHF components. Featuring the same solid construction and dependable RF performance as the original, the newly designed components feature 996 selectable frequencies and backlit LCD screens with Soft Touch Controls for easy navigation and programming.

**ATW-1821D Kit includes** (1) ATW-R1820, (2) ATW-T1801 & (2) Omnidirectional lavalier mics #AUATW1821D..... **\$1295.00**  
**ATW-1822D Kit includes** (1) ATW-R1820 & (2) ATW-T1802 #AUATW1822D ..... **\$1295.00**  
**ATW-1823D Kit includes** (1) ATW-R1820, (1) ATW-T1801, (1) ATW-T1802 & (1) Omnidirectional lavalier mic #AUATW1823D.. **\$1295.00**

- Dual-channel UHF on-camera wireless system
- ATW-R1820 receiver features independent monitor and output level controls
- One receiver may be powered down for battery conservation
- ATW-T1801 belt pack transmitter features selectable hi/low power output
- Includes MT830 omnidirectional lavalier
- ATW-T1802 plug on transmitter features phantom power



**AZDEN**  
**1000 Series**

The 1000 series represents a versatile array of UHF wireless components and the 121 channel diversity 1000URX receiver has the distinct ability to be mounted directly to a variety of professional cameras. The 1000BT bodypack transmitter and 1000XT plug-in transmitter round out the set.

**1000URX** on-camera diversity wireless receiver #AZ1000URX..... **\$539.95**  
**1000URX/ AB** on-camera receiver configured for Anton Bauer "Gold Mount" mounting system #AZ1000URXAB..... **\$599.95**  
**1000URX/ Si** on-camera receiver configured for Panasonic or Ikegami "Slot-In" or "Uni-Slot" mounting systems #AZ1000URXSI..... **\$863.95**  
**1000URX/ VM** on-camera receiver configured for IDX "V-Mount" mounting system #AZ1000URXVM..... **\$774.95**  
**1000BT** bodypack transmitter #AZ1000BT..... **\$229.95**  
**1000XT** plug-on transmitter #AZ1000XT..... **\$229.95**



# ENG AUDIO KITS

## Complete Solutions for Field Audio Production

B&H sells a variety of kits for wireless microphones, complete boompole systems, and ENG mixers and accessories. They're designed to take the guesswork out of building an audio package for location sound applications. They act as a "value menu" of sorts—you get everything you need in one shot, and you'll save yourself some money, too. B&H's wireless microphone kits are sold as single or dual systems and come in two levels: Basic and Deluxe. Our deluxe kits include broadcast-quality lavalier microphones that are significantly better than the standard mics included with the wireless system. With the variety of kits that we offer, you can mix and match them for your ideal booming, wireless, and mixing solutions.

### SENNHEISER

#### ME66/K6

##### Basic Shotgun Kit

##### Kit Includes:

SEME66 K6 shotgun microphone, Rode SM 3 shock mount, K-Tek KE-89CC aluminum boompole, Rycote Softie (\$110), Universal hand grip, 20-ft. XLR cable with right-angle female connector, 1.5-ft. XLR cable with right-angle female connector.



#SEME66BK  
**\$749<sup>95</sup>**

##### ME66/K6 Deluxe Kit-

includes K-Tek KE-100CC carbon fiber boompole #SEME66DK ..... **\$969.95**

### RODE

#### NTG-2

##### Basic Shotgun Kit

##### Kit Includes:

NTG-2 shotgun microphone, Rode SM 3 shock mount, K-Tek KE-89CC aluminum boompole, Rycote softie (\$110), Universal hand grip, 20-ft. XLR cable with right-angle female connector, 1.5-ft. XLR cable with right-angle female connector.



#RONTG2BK  
**\$579<sup>95</sup>**

NTG1 Basic Kit #RONTG1BK ..... **\$559.95**

### SENNHEISER

#### MKH-416

##### Deluxe Shotgun Kit

##### Kit Includes:

MKH-416 P48 shotgun microphone, Rode SM 3 shock mount, K-Tek KE-100CC carbon fiber boompole, Rycote softie (\$110), Universal hand grip, 20-ft. XLR cable with right-angle female connector.



#SEMKH416DK  
**\$1699<sup>95</sup>**

### AUDIO-TECHNICA

#### AT-897

##### Basic Shotgun Kit

##### Kit Includes:

AT-897 shotgun microphone, Rode SM 3 shock mount, K-Tek KE-89CC aluminum boompole, Rycote softie (\$110), Universal hand grip, 20-ft. XLR cable with right-angle female connector, 1.5-ft. XLR cable with right-angle female connector.



#AUAT897BK  
**\$599<sup>95</sup>**

**SENNHEISER**

**EW100 G2**

**Single Basic Wireless ENG Kit**

**Kit Includes:**

EW100 G2 wireless microphone system (SK100 G2 bodypack transmitter, SKP100 G2 plug-in transmitter, ME2 lavalier mic), Electro Voice RE50B handheld interview microphone, 2.25" square mic flag (black), Pearstone plug-in transmitter case #PEUPOH, Pelican #1200 case with foam insert.



#SEEW100EB\*K  
**\$779<sup>95</sup>**

**EW100 G2 Deluxe Kit-** Includes Voice Technologies VT500 lavalier #SEEW100ED\*K.....**\$989.95**

**SENNHEISER**

**EW100 G2**

**Dual Deluxe Wireless ENG Kit**

**Kit Includes:**

EW100 G2 wireless microphone system (SK100 G2 bodypack transmitter, SKP100 G2 plug-in transmitter, ME2 lavalier mic), EW 112 G2 wireless system (SK100 G2 bodypack transmitter, EK100G2 camera-mount receiver, ME2 lavalier mic), (2) Voice Technologies VT500 Lavalier Microphones, Electro Voice RE50B handheld interview microphone, dual hot shoe extender, Pelican #1200 case with foam insert.



#SEEW100DD\*K  
**\$1679<sup>95</sup>**

**EW100 G2 Dual Basic Kit #SEEW100DB\*K.....\$1249.95**

**AUDIO-TECHNICA**

**ATW-1821D**

**Deluxe Wireless Kit**

**Kit Includes:**

ATW-R1820D Camera mountable Dual-Receiver, (2) ATW-T1801 bodypack Transmitters, ATW-1802 plug-in Transmitter, (2) AT-899CW Omnidirectional Lavalier Microphones, professional ENG handheld microphone, cables, mic flag and rugged storage case



#AUATW1821DDK  
**\$1799<sup>00</sup>**

**SONY**

**UWP**

**ENG Deluxe Wireless Kit**

**Kit Includes:**

UWP-C1 true diversity portable camera-mountable UHF wireless lavalier microphone system, UTX-P1 UWP plug-on transmitter, Sony ECM-44BMP omni-lavalier microphone, Sony F112 handheld ENG microphone, 2" square mic flag, Pelican #1200 case with foam insert.



#SOUWPED6\*K  
**\$989<sup>95</sup>**

**UWP Series ENG Dual Deluxe Kit #SOUWPEDD6\*K..\$1599.95**

**SOUND DEVICES**

**302**

**Deluxe Field Mixer Kit**

**Kit Includes:**

Sound Devices 302 3-channel mixer, PEGZ-1 Eargonizer Audio Organizer, HS1N Professional Audio Harness, (2) 1" x 6" carabiner cable carriers, 25-ft. Canare breakaway cable, (3) AA batteries.



#S0302DK  
**\$1739<sup>00</sup>**

**442 ENG/EFP Deluxe Field Mixer Kit #S0442DK.....\$2994.95**

**PSC**

**DV PROMIX 6**

**ENG/EFP Deluxe Field Mixer Kit**

**Kit Includes:**

PSC DV ProMix 6 6-Channel mixer, Porta-Brace RM deluxe wireless microphone/ audio mixer case, Versa-Flex professional field audio harness, (2) 1" x 6" carabiner cable carriers, 25-ft. Canare breakaway cable, (8) AA batteries.



#PSDVP6DK  
**\$1779<sup>95</sup>**



**SHURE**

**UHF-R Series w/KSM9**

#SHUR24SKSMBL  
**\$3679<sup>00</sup>**

Featuring patented Audio Reference Companding, the UHF-R Wireless System is engineered for uncompromised large-scale touring and fixed-install sound applications. Shure's Advance Track Tuning provides superior filtering of all 2400 available frequencies, maximizing signal isolation from interference. Integrated Wireless Workbench software with Ethernet and USB compatibility gives users advanced, real-time control and flexible monitoring of up to 108 systems. The UR4S single-channel and UR4D dual-channel receivers are matched perfectly with a variety of high-quality Shure transmitters.



The KSM9 dual-diaphragm condenser microphone is the premier choice for world-class touring sound. Designed to reveal every detail of the most critical sound applications effortlessly, the UHF-R Series offers switchable cardioid and super-cardioid polar patterns and an advanced two-stage shock-mount suspension.



- Dual, externally biased, ultra-thin, gold-layered, low mass, Mylar diaphragm design
- Mechanical polar pattern switch for consistent pattern integrity
- Durable zinc die-cast housing and hardened low carbon steel grille
- Gold-plated internal and external electronic component connectors
- Advanced two-stage shock mount reduces unwanted noise
- Balanced XLR outputs, USB, RJ-45 Ethernet 1/4" unbalanced

<b>UR24SKSM</b> Single Diversity Handheld System w/KSM9 head #SHUR24SKSM*	<b>\$3679.00</b>
<b>UR24SSM58</b> Single Diversity Handheld System w/SM58 head #SHUR24SSM58*	<b>\$2659.00</b>
<b>UR124S87</b> Dual Diversity Combo System w/Beta87C head & UR-1 Bodypack #SHUR124S87*	<b>\$3829.00</b>
<b>UR14D</b> Dual Diversity System with (2) UR-1 Bodypack transmitters #SHUR14D*	<b>\$4419.00</b>

**SHURE**

**ULX-Series**

Ideal for working musicians and professional sound installers, this UHF system provides over 1400 selectable, pre-programmed frequencies, multiple system configurations and reliable operation and setup with a 300-foot transmission range. Both available ULX series receivers display active groups, channels, and frequencies, and are available in multiple-frequency sets. A large assortment of high-quality Shure transmitters are available for use with the system, all of which utilize Shure's Automatic Frequency Selection, providing the quickest path to the clearest, RF-free channels.

- 1400 selectable frequencies with Automatic Frequency Selection
- Multiple system configurations provide limitless options
- Multi-function LCD and RF presence LED
- Predictive Diversity
- In-line power
- XLR and 1/4" outputs



<b>ULXS14J1</b> Standard diversity Instrument System w/WA302 cable #SHULXS14J1	<b>\$629.00</b>
<b>ULXS1493J1</b> Standard diversity Lavalier System w/WL93 lavalier mic #SHULXS1493J1	<b>\$689.00</b>
<b>ULXS2458J1</b> Standard diversity Handheld System w/SM58 head #SHULXS2458J1	<b>\$689.00</b>
<b>ULXS1430J1</b> Standard diversity Head-worn System w/WH30TQG mic #SHULXS1430J1	<b>\$729.00</b>

**Available Transmitters (available in multiple frequencies)**

<b>ULX2Beta87A</b> Beta 87A super-cardioid condenser handheld #SHULX2B87AJ1	<b>\$389.00</b>
<b>ULX2Beta87C</b> Beta 87C cardioid condenser handheld #SHULX2B87CJ1	<b>\$389.00</b>
<b>ULXBeta58</b> Beta 58 cardioid handheld #SHULX2B58J1	<b>\$319.00</b>
<b>ULX287</b> SM87 cardioid condenser handheld #SHULX287J1	<b>\$389.00</b>
<b>ULX286</b> SM86 cardioid condenser handheld #SHULX286J1	<b>\$319.00</b>
<b>ULX258</b> SM58 cardioid handheld #SHULX258J1	<b>\$269.00</b>
<b>WA610</b> Hard Shell Carrying Case #SHWA610	<b>\$82.95</b>
<b>WL93</b> Omni Condenser Sub-mini Lavalier mic w/TA4F connector #SHWL93	<b>\$69.95</b>
<b>WH20TQG</b> Cardioid Dynamic Head-worn mic w/TA4F connector #SHWH20TQG	<b>\$79.50</b>

**SHURE**  
**SLX-Series**

Working bands, theater groups, and presenters who need reliable wireless performance with simple setup and operation will appreciate Shure's SLX UHF Series. Its diversity technology is designed to improve reception, minimize dropouts, and operate at distances of up to 300 feet. Users can operate up to 20 simultaneous systems that can be configured over 960 different frequency bands. Multiple systems integrate easily into reception halls, institutions and houses of worship.

- 960 frequency with Auto Frequency Selection (locates clearest channel)
- Auto Transmitter Setup automatically syncs transmitter and receiver
- High-quality Audio Reference Companding for pristine audio transmission
- In-line power • Backlit LCD • XLR and 1/4" outputs



<b>SLX14</b> Diversity Bodypack Instrument System w/WA302 cable #SHSLX14L4.....	<b>\$559.00</b>
<b>SLX1493</b> Diversity Bodypack Lavalier System w/WL93 mic #SHSLX1493L4.....	<b>\$599.00</b>
<b>SLX2458</b> Diversity Handheld System w/SM58 head #SHSLX2458*.....	<b>\$599.00</b>
<b>SLXWH30</b> Diversity Bodypack Headset System w/WH30 mic #SHSLX14WH*.....	<b>\$659.00</b>

**Available Transmitters (available in multiple frequencies)**

<b>SLX2Beta87C</b> Beta 87 cardioid condenser handheld #SHSLX2B87C*.....	<b>\$297.95</b>
<b>SLX2Beta87A</b> Beta 87 supercardioid condenser handheld #SHSLX2B87A*.....	<b>\$297.95</b>
<b>SLX2Beta58</b> Beta 58 cardioid handheld #SHSLX2B58*.....	<b>\$222.50</b>
<b>SLX2SM86</b> SM86 cardioid condenser #SHSLX286*.....	<b>\$222.50</b>
<b>SLX2SM58</b> SM58 cardioid handheld #SHSLX258*.....	<b>\$192.50</b>
<b>WL93</b> Omni Condenser Sub-mini Lavalier mic w/TA4F connector #SHWL93.....	<b>\$69.95</b>
<b>WH20TQG</b> Cardioid Dynamic Headworn mic w/TA4F connector #SHWH20TQG.....	<b>\$79.50</b>

**SHURE**  
**PGX-Series**

The Shure PGX Wireless System was created especially for solo vocalist acts, presenters and mobile DJ's who manage their own sound. It's easy to set up and improves performance with innovations such as automatic frequency/transmitter setup, Audio Reference Companding, and more. Synchronize transmitter and receiver frequencies easily with one button push while monitoring signal strength from the multi-colored front panel audio LED. 90 frequencies are available for guitars, instruments, and vocals.

- Patented Audio Reference Companding of 90 different frequencies (single-channel)
- Multi-colored audio level LCD
- Simple one-button system synchronizing and setup
- XLR and 1/4" outputs



<b>PGX14H6</b> Diversity Bodypack System w/WA302 Instrument cable #SHPGX14H6.....	<b>\$449.00</b>
<b>PGX24PG58L5</b> Diversity Handheld System w/PG58 head #SHPGX24PG58*.....	<b>\$379.00</b>
<b>PGX1493J6</b> Diversity Bodypack System w/WL93 lavalier mic #SHPGX1493H6.....	<b>\$419.00</b>
<b>PGX14PG30J</b> Diversity Headset System w/WH20TQG mic #SHPGX14PG30*.....	<b>\$429.00</b>

**Available Transmitters (available in multiple frequencies)**

<b>PGX2Beta58</b> Beta 58 supercardioid handheld #SHPGX2B58*.....	<b>\$219.95</b>
<b>PGX2SM86</b> SM86 cardioid condenser handheld #SHPGX2SM86*.....	<b>\$213.50</b>
<b>PGX24SM58</b> SM58 cardioid handheld #SHPGX2SM58*.....	<b>\$169.95</b>
<b>PGX24PG58</b> PG58 cardioid handheld #SHPGX2PG58*.....	<b>\$153.50</b>
<b>WL93</b> Omni Condenser Sub-mini Lavalier mic w/TA4F connector #SHWL93.....	<b>\$69.95</b>
<b>WH20TQG</b> Cardioid Dynamic Headworn mic w/TA4F connector #SHWH20TQG.....	<b>\$79.50</b>

**SHURE**

**Performance Gear Series - Dual**

#SHPG288PG58M  
**\$549<sup>00</sup>**

The Performance Gear Series is a wireless UHF system with 8 selectable frequencies, consisting of a PG88 dual-receiver chassis and a pair of PG2 handheld microphone transmitters with SM58 cardioid capsules. The system features dual simultaneous operation on independent frequencies, tabletop or rackmount receiver design, and twin-antenna diversity reception for minimized RF dropout and interference. The system is a good choice for school, karaoke, club-date, and presentation applications.



- Dual UHF transmitter/receiver system with simultaneous operation
- 8 user-selectable frequencies • XLR and 1/4" outputs
- Clear diversity reception minimizes dropout

**SHURE**

**Performance Gear Series - Single**

#SHPG24PG58M7  
**\$299<sup>00</sup>**

The Performance Gear Series UHF system offers low-cost frequency-agile wireless microphone technology with a dual-antenna PG4 receiver and a robust PG2 handheld transmitter with a cardioid SM58 capsule. The receiver sports RF-free diversity reception and rackmount capability, and the transmitter capsule is an industry-standard stage vocal microphone. The system is a fine solution for stage, club-date, school, and presentation applications.



- Tabletop or rackmount UHF receiver, SM58 transmitter capsule
- 8 user-selectable frequencies • XLR and 1/4" outputs
- Optional URT rack tray for receiver
- 8-hr AA or rechargeable 9V battery life for transmitter

**AUDIO-TECHNICA**

**2000 Series**

#AUATW2120  
**\$349<sup>00</sup>**



Featuring the handheld ATW-T220 cardioid microphone, the ATW-2120 is a true diversity UHF wireless system that provides the features and sound quality of units costing much more. With a single button press, the ATW-2100 receiver automatically scans the frequencies, searching for the best available channel. Any of its 10 channels may be used together, eliminating confusing frequency groups and other frequency coordination problems. The metal, half-rack receiver features soft-touch controls and an LCD screen with RF and audio level metering.

- All 10 user-switchable channels are compatible for use with multiple systems
- Automatic one-touch frequency scanning
- ToneLock tone squelch system reduces interference
- Rugged metal half-rack chassis with ground-lift switch for hum elimination
- ATW-2110 bodypack system accepts instruments or mic line inputs
- XLR and 1/4" outputs

**ATW-2110** bodypack system w/ATW-T210 UniPak transmitter  
#AUATW2110.....**\$299.00**

**AUDIO-TECHNICA**

**3000 Series**

#AUATW3141AD  
**\$499<sup>00</sup>**

The ATW-3141 is a mid-priced handheld wireless system featuring 200 PLL-synthesized channels per band and the Artist Elite AE4100 cardioid dynamic element. Its true diversity system auto-selects the cleanest frequency from both channels and provides advanced digital ToneLock squelch for improved performance. Up to 16 systems may be used simultaneously for a total of 32 systems across two bands.

- 200 selectable UHF channels
- Automatic Frequency Scanning locks on clearest frequency
- Advanced Digital ToneLock squelch with true diversity operation
- LCD screen with step-through menus and transmitter battery-life fuel gauge
- ATW-3110 bodypack system accepts instruments or mic line inputs
- XLR and 1/4" outputs



**ATW-3110** bodypack system w/ATW-T310 UniPak transmitter #AUATW3110AD.....**\$399.00**



**AUDIO-TECHNICA**

**4000 Series**

#AUAEW4240D  
**\$829<sup>00</sup>**

The AEW-4240 is a premium handheld UHF wireless system from the 4000 series. It combines a true diversity AEW-4110 receiver with the AEW-T4100 dynamic cardioid microphone. 200 clear, reliable channels are available utilizing IntelliScan, a feature that automatically finds the best available frequencies on all linked receivers. Audio quality is optimized by providing Digital Tone Lock Squelch and dual-companding circuitry, effectively blocking RF interference while handling high and low frequencies independently.

- 200 selectable UHF channels with true diversity reception
- Link and coordinate multiple receiver channels
- Dual compander circuitry processes high and low frequencies independently
- Receiver and transmitter feature comprehensive LCD screen providing frequency, channel, battery, and signal status
- Rugged, all metal chassis



- Transmitter battery "fuel gauge" with low-battery warning display
- IntelliScan feature automatically locates and sets best available frequencies on all linked receivers
- Cardioid element with superior gain before feedback
- XLR and 1/4" outputs

**ATW-4110** bodypack version with AEW-T1000 UniPak transmitter #AUAEW4110D ..... **\$769.00**



**AUDIO-TECHNICA**

**5000 Series**

#AUAEW5266D  
**\$2399<sup>00</sup>**

The 5000 Series of dual-transmitter UHF wireless microphone systems offer professional sound, diversity reception, and 200 user-selectable frequencies for use in theaters, houses of worship and touring rigs. Comprised of the AEW-R5200 rack mount dual-receiver and a pair of AEW T-6100 handheld transmitters with tight hypercardioid capsules, the system provides dual backlit LCD screens, Dual Compander circuitry and Intelliscan frequency autosearch for optimal reception.

- Dual UHF receiver/transmitter wireless system
- 200 user-selectable frequencies
- XLR and 1/4" outputs
- Networking via RJ45 computer interface
- Diversity reception with Intelliscan auto-search

**SONY**

**UWP-S Series**

#SOUWPS266  
**\$499<sup>95</sup>**

Sony's UWP2 series delivers an affordable, reliable wireless microphone system to the budget-conscious user. It utilizes its Space Diversity design over 188 selectable UHF frequencies to stabilize reception by selecting the strongest incoming signal. With 188 selectable UHF frequencies, Sony's unidirectional dynamic handheld microphone transmitter, and easy-to-access programmable functions, the UWP2 system is truly adaptable to virtually any live PA application.

- Transmitter and receiver provide 188 selectable synthesized UHF frequencies
- 16 System Simultaneous Operation
- Pilot tone squelch
- (PLL) Phase Locked Loop provides minimal interference and dropout
- 5 mW-30 mW switchable RF output power
- LCD screen provides channel and frequency information, battery life, and usage time
- Space diversity operation eliminates signal dropout



- 1/4" phone and XLR outputs are capable of mic and line-level signals

**AKG**  
**WMS40**

The WMS40 is a UHF dual wireless microphone system featuring simultaneous operation of two mic/transmitters, and is comprised of the SR40 dual receiver and a pair of matching HT40 Pro handheld transmitters with cardioid capsules. The half-rack receiver is equipped with twin antennas and LED's, while the transmitters offer tight pickup and an efficient 30-hr. battery life. The system provides an AKG-quality solution for schools, stage, club, and presentation work.

- Cost-effective dual UHF wireless microphone system
- Dual transmitters with tight pick-up pattern
- XLR with switchable output level, 1/4" outputs
- 30-hr. single AA battery life for transmitters



#AKW40PDH54  
**\$349<sup>00</sup>**

**ELECTRO VOICE**  
**RE-2 Series**



The Electro Voice RE2N7A is an affordable dual-diversity wireless system with 1,112 selectable UHF frequencies and EV's patented easy-to-use automatic ClearScan function. The system comes equipped with the popular N/D767A supercardioid dynamic microphone element and ergonomically designed HTU-2 handheld transmitter.

- 1,112 Switchable UHF Frequencies
- ClearScan Automatic Scanning
- 16 Simultaneous System Operation
- Optional RE-510 Condenser Mic Element
- Balanced XLR and 1/4" outputs

##ELRE2N7A  
**\$494<sup>00</sup>**

<b>APD4+</b> 4 output antenna distribution system #ELAPD4 .....	<b>\$399.00</b>
<b>LPA500</b> Log Periodic Antenna that provides 5dB in its direction #ELLPA500 .....	<b>\$239.00</b>
<b>RMS</b> single rack mount kit #TERMS .....	<b>\$40.50</b>

**TELEX**  
**FMR-1000 UHF**

The FMR-1000 series from Telex is a professional UHF diversity wireless system capable of operating up to 16 simultaneous systems with over 950 possible channels. Telex's Advanced ClearScan makes system setup simple with automatic group and channel selections. The FMR-1000 receiver features a parametric EQ for mixerless sound shaping, backlit LCD screen showing the Group/Channel, transmitter battery status, diversity operation, RF and audio level meters, and custom label space. Both handheld and bodypack systems are available.

- Frequency-agile UHF wireless system with over 950 possible channels
- Ideal for permanent installs including houses of worship, government/educational institutions
- Unique battery circuit means there is no wrong way to insert battery (8hr. alkaline battery life).
- Unique sound check allows one person to walk and test system functionality.
- XLR and 1/4" outputs



<b>FMR-1000</b> handheld system with HT-1000 transmitter and N/D767 capsule #TEFMR1000HDA .....	<b>\$1179.00</b>
<b>FMR-1000</b> bodypack system with WT-1000 belt-pack transmitter #TEFMR1000WTA .....	<b>\$1129.00</b>

**SENNHEISER**

**G2-100 Series**

Quickly becoming a favorite among performers, installers, and touring engineers, the Sennheiser Evolution-G2 Series 135 wireless microphone system offers great functionality and performance at an attractive price. The system features 1,140 selectable UHF frequencies, pilot-tone squelch, auto-scanning, and the MD835 dynamic cardioid mic element.

- 1,140 Tunable UHF Frequencies
- AutoScan Function
- 4 Switchable Preset Channels
- Variable Sensitivity Settings
- Variable Level Control

<b>SK100G2A</b> Bodypack transmitter designed for the EW100 system #SESK100G2A.....	<b>\$227.50</b>
<b>ME2</b> Omnidirectional electret-condenser lavalier microphone #SEME2.....	<b>\$129.95</b>
<b>ME4</b> Cardioid electret-condenser lavalier microphone #SEME4.....	<b>\$129.95</b>
<b>ZH100-ANT</b> Pin-style, lavalier clothing clip #SEZH100B.....	<b>\$12.50</b>
<b>NB2</b> Adjustable Headset Boom for lavalier microphones #SENB2.....	<b>\$59.95</b>
<b>A1031-U</b> Wideband passive omnidirectional UHF antenna (pair) #SEA1031U.....	<b>\$139.95</b>
<b>ASP2/NT1</b> Passive antenna splitter kit w/power supply #SEASP2NT1.....	<b>\$483.50</b>
<b>AB2</b> Antenna RF booster module #SEAB2A.....	<b>\$183.50</b>
<b>GA2</b> Rack Kit allows mounting of two receivers in single rack space #SEGA2.....	<b>\$67.95</b>

#SEEW135G2A  
**\$549<sup>99</sup>**



**AUDIO TECHNICA**

**700 Series Freeway**



The 700 Series Freeway is a compact, high-quality UHF handheld wireless microphone system with 8 selectable frequencies and dropout-free diversity operation for the receiver. The ATW-T702 transmitter features switchable RF output power, a dynamic, high-SPL cardioid capsule and a 10-hr. battery life. The system is an excellent low-cost solution for presentation, classroom, and small club wireless microphone requirements.

- UHF handheld wireless microphone system
- 8 selectable frequencies
- XLR and 1/4" audio connectors
- Diversity operation, switchable RF output for transmitters

#AUATW702  
**\$249<sup>95</sup>**

**SENNHEISER**

**G2-300 Series**

The EW365 G2 is a professional UHF handheld vocal performance wireless system consisting of the supercardioid MD865 condenser microphone and SKM300 G2 handheld transmitter. Flexible and powerful, this system gives users 8 switchable presets which are reprogrammable to any of the 1440 available frequencies, peak-hold level, and battery meter status indicators.

- 1440 reprogrammable frequencies to 8 presets
- Auto-scan on all receivers for simple, secure frequency selection
- Pilot-tone squelch for superior frequency lock and rejection
- Robust rack-mountable metal chassis
- Audio signal metering on transmitter LCD screen
- XLR connectors

<b>EW335G2</b> handheld wireless with MD835 cardioid microphone #SEEW335G2A.....	<b>\$879.00</b>
<b>EW322G2</b> bodypack wireless with cardioid lavalier ME4 microphone #SEEW322G2A.....	<b>\$879.00</b>
<b>EW372G2</b> instrument wireless with cable #SEEW372G2A.....	<b>\$849.00</b>

#SEEW365G2A  
**\$999<sup>00</sup>**





**LECTROSONICS****Venue Receiver System**

Providing outstanding audio quality and superior flexibility, the Lectrosonics Venue System is a modular, six-channel, 256-frequency UHF Digital Hybrid Receiver that works with Digital Hybrid and various analog wireless transmitters. The system offers pristine noise-free operation that is achieved through proprietary DSP that digitally encodes audio at the transmitter, sends a 24-bit data stream via an FM wireless link, and decodes it at the receiver. This compander-free operation produces impressive, high-quality results never before achieved in professional performance applications.

- 256 synthesized UHF frequencies per receiver module
- Configurable to suit a multitude of applications
- DSP compatibility mode ensures operation with multiple types of transmitters
- Multiple diversity mode operation
- LCD interface for setup and monitoring
- USB and RS-232 computer interface for setup and operation with Windows based PC's

#LEVRM2122  
**CALL**

**X2 DIGITAL WIRELESS SYSTEMS**  
**XD Series**

Designed specifically for instrument applications, this 24-bit digital system delivers your tone and performance with the sound and feel of a direct wire connection - all at a price that won't break the bank. X2's proprietary digital technology provides superior fidelity as well as eliminating dropouts and interference, including DTV. This system was designed to perform as clean as a cable by eliminating many of the problems associated with analog wireless technology. Gone are the days of the incessant "pumping" and "breathing" effect caused by compander IC's that can squash your tone and prevent the true sound of your instrument from ringing through.

#X2XDS95  
**\$299<sup>99</sup>**

- 24-bit linear AD/DA converters capture your exact performance
- No compander IC's that inevitably squash your sound
- 900 MHz UHF transmission means no DTV or licensing concerns
- Compact "stomp-box" receiver fits in your guitar case
- 9V battery or optional AC adapter means no 220V concerns

**AKG****WMS 450 Vocal Set**

The WMS 450 Vocal Set is a handheld UHF wireless microphone system with diversity reception, 12 preset channels per 1200 carrier frequencies, and a cardioid condenser element for the transmitter. The SR450 receiver features diversity reception and an integrated frequency scan function for optimized reception. The HT450C transmitter capsule offers excellent detailing and high output level. The system is an excellent mid-priced professional presentation and lecture wireless solution.

- UHF handheld wireless system with sensitive condenser transmitter capsule
- 12 selectable preset channels, frequency scanning
- XLR and 1/4" outputs • Antenna diversity operation

#AK450HHSC51  
**\$649<sup>00</sup>**

**AMT****Roam 1 Elite**

Ideal for brass, woodwinds and strings, the Roam 1 Elite is a high-quality universal UHF instrument microphone system that combines an AMT cardioid condenser microphone, its 4-point isolation ring shock-mount, and a Samson wireless system complete with transmitter and receiver. Its contoured frequency response and mounting system delivers a clean, accurate response while minimizing troublesome vibrations and "proximity effects."

- Easy to set up wireless single-channel UHF performance
- AMT AH1 horn microphone with Samson Airline Transmitter and Concert 77 receiver
- Cardioid condenser element • 4-point Isolation Mount absorbs vibration and shock
- Power On, Peak, RF Level, and Receiver Diversity LED's
- Balanced XLR and unbalanced 1/4" outputs

#AMR1EU6  
**\$589<sup>00</sup>**

**AUDIO TECHNICA**

**Freeway 200 Series**

The Freeway 200 wireless series represents a great balance between performance and affordability. Operating with VHF technology, these systems deliver clear natural sound quality, easy setup, and reliable transmission. Each system includes a dual antenna receiver and either a body-pack transmitter or a handheld microphone/transmitter on a specific crystal controlled frequency. With no channels to set or menus to scroll through, this system is both quick and easy to work with and its compact size saves space when mounting multiple systems.

- Reliable performance and durable construction
- Power, RF, and AF peak indicators
- 1/4" output jack and pace saving power supply
- Variable mic trim and On/Standby/Off switch
- Professional locking connector on body-pack



<b>AUATW252T*</b> handheld system .....	<b>\$99.95</b>	<b>AUATW251H*</b> headset system .....	<b>\$144.95</b>
<b>AUATW251LT*</b> lavalier system .....	<b>\$124.95</b>	<b>AUATW251G*</b> instrument system .....	<b>\$99.95</b>

**SAMSON**

**Concert/Airline Combination System**

These single channel UHF systems combine the full sized Samson Concert Series base receivers with the compact line of Airline transmitters to create packages that perform exceptionally well at a fantastic price. Airline transmitters operate on inexpensive and lightweight AAA's that offer 14 hours operation on a single battery and the CR77 receiver features multi-segment audio level, RF level and A/B antenna meters. Outputs are provided for XLR and 1/4" and there are front panel controls for both level and squelch.

- True diversity UHF single channel wireless systems
- Tuned molded antennas for accurate reception
- Small and lightweight Airline transmitters
- Handheld system includes Q7 mic and AX-1 plug-in transmitter
- Lavalier system includes QL5 lav mic and AL1 bodypack



<b>SAAL77HH*</b> handheld system .....	<b>\$259.00</b>
<b>SAAL77PQL*</b> lavalier system .....	<b>\$319.00</b>

**ELECTRO VOICE**

**REV Series**

The REV multichannel UHF wireless series from Electro Voice offers true professional performance and features the ability to support up to 16 simultaneous systems with factory settings or up to 44 systems with custom groups. The advanced ClearScan automatic group and channel selection feature allows quick, simple setup and each receiver's large backlit display keeps you updated on Group/Channel, transmitter battery status, diversity operation, RF, and audio level with space to spare for a custom name. Comfortable handheld and lightweight belt-pack transmitters both feature selectable 5 or 50mW output options.

- Optimized analog audio path for truest sound possible
- Battery level gauge on transmitters and receivers
- Sound Check mode for easy walk testing
- Smart-Battery circuit insures correct battery placement
- Dual receivers feature antenna pass through jacks



<b>ELREVS*</b> single rackmount receiver .....	<b>\$1,359.00</b>
<b>ELREVD*</b> dual rackmount receiver .....	<b>\$1,699.00</b>
<b>ELREVPHD9*</b> handheld transmitter w/ ND967 supercardioid capsule .....	<b>\$469.00</b>
<b>ELREVPHD7*</b> handheld transmitter w/ ND767 supercardioid capsule .....	<b>\$439.00</b>
<b>ELREVPHC5*</b> handheld transmitter w/ RE510 supercardioid capsule .....	<b>\$469.00</b>
<b>ELREVPHC4*</b> handheld transmitter w/ RE410 supercardioid capsule .....	<b>\$469.00</b>

**SHURE****PSM-200 System**

The Shure PSM 200 is a personal, monaural in-ear wireless monitoring system ideal for the working musician. Its unique analog hybrid bodypack receiver, eight selectable UHF frequencies, and auto scanning function ensure users will always have the best available channel at any performance venue.

- 8-Selectable UHF Frequencies
- Channel Scan Mode monitors and selects from clearest, RF-free operating frequency
- Built-In Auto Limiter controls output level reducing noise and distortion
- Two Mic/Line Neutrik Combo Jack Connectors
- Transmitter provides the connector link to the house or monitor mixing console
- P2R Hybrid Bodypack functions as wired or wireless receiver

#SHP2TRE2  
**\$599<sup>00</sup>**

**SHURE****PSM-700 System**

Engineered with a functional feature set that addresses the needs of demanding touring professional musicians, the high-quality Shure PSM 700 stereo in-ear wireless UHF system provides clean, detailed sound reproduction and outstanding performance. Equipped with the P7T rackmount transmitter, rugged P7R bodypack receiver and high-energy dual-driver SCL5 sound isolating ear-buds, the PSM 700 is an excellent choice for personal monitoring in any live performance situation.

- 32 Selectable UHF Frequencies
- Stereo, Mono, or MixMode — control for custom monitor mixes
- Up to 16 Simultaneous System Operation
- Low-mass, high-energy SCL5 Stereo Earbuds Provide Great Accuracy and Isolation
- Pilot Tone Squelch
- Loop out connectors on P7T for multiple mix setups and easy installation
- Durable All Metal Construction

#SHP7TRE3L2  
**\$1999<sup>00</sup>**

**SENNHEISER****Evolution G2-300 Series**

Designed for touring musicians, the Sennheiser EW300IEM-G2 is a high-performance wireless stereo in-ear monitor system with 1,140 user-selectable UHF frequencies, automatic scanning, and high-quality (HDX) noise-reduction circuitry. Providing users with a new level of on-stage monitoring, the frequency-agile, ruggedly-constructed 300IEM system is an ideal choice for reliable wireless performance.

- 4 Factory Preset Channels for quick channel selection
- AutoScan Function
- Sennheiser HDX Noise Reduction
- Stereo Focus Balance Control
- Variable Sensitivity Control
- Switchable High-Boost and Safe Monitoring Mode

#SEEW300IEM2A  
**\$949<sup>00</sup>**

**TELEX****SoundMate SM-2 Base Transmitter System**

Featuring intuitive controls, seamless system integration, and low-noise high-output operation, the Telex Soundmate Personal Listening System is ideally suited for assistive listening in houses of worship, municipal facilities, and environments where ambient noise and poor room acoustics compromise speech intelligibility. The SM-2A system is comprised of the full-featured, frequency-agile ST-300 base transmitter with up to 17 channels of VHF operation and includes four frequency-matched SR-50 single-channel receivers with SEB-1 earbuds.

- 17 Selectable VHF Channels
- Base Transmitter offers versatile connectivity to sound systems, mixers, and dynamic microphones
- Backlit LCD for easy navigation
- Enhanced Dynamic Range feature when coupled with SR-400 receiver provides clearer, more dynamic audio

#TESM2A  
**\$745<sup>00</sup>**

**HED-3** Noise-reduction headphones #TEHED3...**\$58.50** **PST170** Beltpack Transmitter #TEPST170...**\$429.00** **DEB2** Dual Earbud with Cord #TEDEB2...**\$12.95**



**AUDIO TECHNICA**

**M2/M3**

The M2 and M3 wireless in-ear monitor systems deliver high fidelity sound for stage performers who are looking for a clean, articulate stage mix at a comfortable volume level. A Personal Mix function adjusts the volume and mix of two independent signals at the receiver giving you independent level control without having to signal the monitor engineer while performing. The M3 gives you 1,321 selectable UHF channels with automatic frequency scanning, backlit LCD displays on both transmitter and receiver, and a detachable receiver antenna. Alternatively, the M2 operates with 100 selectable UHF channels and provides easy to read LED indicators for monitoring.



**#AUM2IEMS ..... \$599.00**

**#AUM3IEMS ..... \$799.00**

- Built-in defeatable limiter protects your hearing
- Use any number of receivers on the same frequency
- Mini jack input connects an ambient mic or click track
- Adjustable squelch eliminates annoying static
- Proprietary earphones with ear-conforming foam tip (3 sizes)

**SHURE**  
**PSM 400 System**

#SHP4TRE3  
**\$799<sup>00</sup>**



The PSM 400 wireless personal monitor system frees you from the limits of conventional floor wedges and lets you experience clear sound at a moderate volume level. At the center of the system, the P4T transmitter features removable/combina antennas for using multiple units, and selectable frequencies let you choose an open channel in interference prone situations. The lightweight P4R wireless belt pack is made of durable high-impact plastic and is designed for quick and intuitive adjustment while on stage. E3 earphones round things out with several interchangeable insert sizes and styles for a custom fit that maximizes both isolation and comfort.

- Optimum 300 ft. operating range
- Up to 8 hrs. use on a single battery
- 4-segment input LED's on transmitter
- Limiter and high-frequency boost on receiver
- Low profile E3 isolation earphones

**GALAXY AUDIO**

**AS-1000**

#GAAS1000  
**\$399<sup>99</sup>**

With 64 user selectable UHF frequencies to choose from, the Any Spot is a wireless personal monitor system that is effective at eliminating stage noise and allows the user to move freely in the performance space while continuing to hear. This cost-competitive system sports easily accessible front panel controls and features a diversity receiver with Auto-Mute which prevents intermittent static from going to the performer's ears. Simply plug a monitor out jack from your mixing console into the AS-1000, create a desirable mix and it's ready to deliver quality sound.

- UHF diversity operation with true mobility
- Multiple receivers may be used with one transmitter
- Great alternative to bulky floor monitors
- Beltpack transmitter may be switched between mono and stereo
- RCA, XLR and 1/4" inputs on transmitter



**ANCHOR-AUDIO**  
**ALB-40**

#ANALB40  
**\$699<sup>99</sup>**



Anchor's reputation in the world of portable public address is unprecedented, and their assistive listening packages deliver the same dependable performance in systems that are both versatile and durable. They feature lightweight in-ear headphones, a range of up to 300 feet and the ability to support an unlimited number of users. It is ideal for houses of worship, theaters, cinemas, auditoriums, classrooms or any situation where people need to better understand speech, music, or other sounds during a presentation or performance.

- 1 base station transmitter
- Easy setup and operation
- 4 beltpack receivers with headphones
- Base station rackmount kit included
- 16 selectable UHF channels
- Comes with light weight carrying case

**ANALD40** Deluxe system includes handheld wireless microphone ..... **\$1,139.99**

**SHURE****PGX Series****Basic Wireless Handheld Microphone Kit****Kit Includes:**

PGX Series Wireless Microphone System, GM-1W Wireless Mobile Pack, 6ft XLR Cable, Pearstone Rapid AC Charger with 4 Rechargeable "AA" 2900mAh NiMh Batteries, (2) ASWS58 Foam Windscreens, (2) Micro Lavalier Clip Microphone Holder (Black)

**\$399<sup>95</sup>****#SHPGX24BHK, #SHPGX24BJK****SHURE****PGX Series****Basic Wireless Lavalier Microphone Kit****Kit Includes:**

PGX Series Wireless Microphone System, GM-1W Wireless Mobile Pack, 6ft XLR Cable, Pearstone Rapid AC Charger with 4 Rechargeable "AA" 2900mAh NiMh Batteries, (2) Micro Lavalier Clip Microphone Holder (Black), (2) 1400 Series Replacement Windscreens

**\$429<sup>95</sup>****#SHPGX14BHK1, #SHPGX14BJK2****SHURE****PGX Series****Basic Wireless Handheld and Lavalier Microphone Combo Kit****Kit Includes:**

PGX Series Wireless Microphone System, PGX-1 Wireless Microphone Body-Pack Transmitter, WL185 Cardioid Lavalier Microphone, GM-1W Wireless Mobile Pack, 6ft XLR Cable, Pearstone Rapid AC Charger with 4 Rechargeable "AA" 2900mAh NiMh Batteries, ASWS58 Foam Windscreen, (2) Micro Lavalier Clip Microphone Holder (Black), (2) 1400 Series Replacement Windscreens

**\$664<sup>95</sup>****#SHPGX24BCHK, #SHPGX24BCJK****SHURE****PGX Series****Basic Wireless Lavalier and Handheld Microphone Combo Kit****Kit Includes:**

PGX Series Wireless Microphone System, PGX-2 Wireless Handheld Microphone Transmitter, GM-1W Wireless Mobile Pack, 6ft XLR Cable, Pearstone Rapid AC Charger with 4 Rechargeable "AA" 2900mAh NiMh Batteries, ASWS58 Foam Windscreen, (2) Micro Lavalier Clip Microphone Holder (Black), (2) 1400 Series Replacement Windscreens

**\$699<sup>95</sup>****#SHPGX14BCHK1, #SHPGX14BCJK1,  
#SHPGX14BCHK2, #SHPGX14BCJK2****SHURE****PGX Series****Dual Wireless Handheld and Lavalier Microphone Combo Kit****Kit Includes:**

PGX Series Wireless Microphone System, PGX-4 UHF Diversity Wireless Microphone Receiver, (2) PGX-1 Wireless Microphone Body-Pack Transmitter, (2) WL93 Professional Micro-Lavalier Omni Mic (Black), (2) GM-1W Wireless Mobile Pack, (2) 6ft XLR Cable, Pearstone Rapid AC Charger with 4 Rechargeable "AA" 2900mAh NiMh Batteries, ASWS58 Foam Windscreen, (2) Micro Lavalier Clip Microphone Holder (Black), (2) 1400 Series Replacement Windscreens

**\$1069<sup>95</sup>****#SHPGX24BDCH1, #SHPGX24BDCH2****SHURE****PGX Series****Dual Wireless Lavalier and Handheld Microphone Combo Kit****Kit Includes:**

PGX Series Wireless Microphone System, PGX-4 UHF Diversity Wireless Microphone Receiver, PGX-2 Wireless Handheld Microphone Transmitter, 6ft XLR Cable, Pearstone Rapid AC Charger with 4 Rechargeable "AA" 2900mAh NiMh Batteries, ASWS58 Foam Windscreen, Micro Lavalier Clip Microphone Holder (Black)

**\$974<sup>95</sup>****#SHPGX14BDCH2, #SHPGX14BDCH1**

**SHURE****PG Series****Wireless Hand Held Basic Kit****Kit Includes:**

PG24 Handheld Microphone System, GM-1W Wireless Mobile Pack, 6ft XLR Cable, Pearstone Rapid AC Charger with 4 Rechargeable "AA" 2900mAh NiMh Batteries, (2) ASWS58 Foam Windscreens

**\$339<sup>95</sup>****#SHPG24BHK, #SHPG24BKK, #SHPG24BMK****SHURE****PG Series****Basic Wireless Lavalier Microphone Kit****Kit Includes:**

PG Lavalier Microphone System, GM-1W Wireless Mobile Pack, 6ft XLR Cable, Pearstone Rapid AC Charger with 4 Rechargeable "AA" 2900mAh NiMh Batteries, 2x Micro Lavalier Clip Microphone Holder (Black), (2) 1400 Series Replacement Wind-screens

**\$344<sup>95</sup>****#SHPG14BHK, #SHPG14BKK, #SHPG14BMK****SHURE****PG Series****Basic Wireless Handheld Microphone and Lavalier Combo Kit****Kit Includes:**

PG24 Handheld Microphone System, PG-1 Body Pack Transmitter, PG185-TQG Cardioid Condenser Lavalier, GM-1W Wireless Mobile Pack, 6ft XLR Cable, Pearstone Rapid AC Charger with 4 Rechargeable "AA" 2900mAh NiMh Batteries, ASWS58 Foam Windscreens, (2) Micro Lavalier Clip Microphone Holder (Black), (2) 1400 Series Replacement Windscreens

**\$484<sup>95</sup>****#SHPG24BCHK, #SHPG24BCKK, #SHPG24BCMK****SHURE****PG Series****Basic Wireless Lavalier and Handheld Microphone Combo Kit****Kit Includes:**

PG Lavalier Microphone System, PGX2 Handheld Transmitter, GM-1W Wireless Mobile Pack, 6ft XLR Cable, Pearstone Rapid AC Charger with 4 Rechargeable "AA" 2900mAh NiMh Batteries, Micro Lavalier Clip Microphone Holder (Black), ASWS58 Foam Windscreens, (2) Micro Lavalier Clip Microphone Holder (Black), (2) 1400 Series Replacement Windscreens

**\$479<sup>95</sup>****#SHPG14BCKK, #SHPG14BCMK, #SHPG14BCHK****SHURE****PG Series****Dual Wireless Lavalier and Handheld Microphone Combo Kit****Kit Includes:**

PG Lavalier Microphone System, PG4 Diversity Receiver, PGX2 Handheld Transmitter, GM-1W Wireless Mobile Pack, (2) 6ft XLR Cable, Pearstone Rapid AC Charger with 4 Rechargeable "AA" 2900mAh NiMh Batteries, Micro Lavalier Clip Microphone Holder (Black), (2) ASWS58 Foam Windscreens, (2) Micro Lavalier Clip Microphone Holder (Black), (2) 1400 Series Replacement Windscreens

**\$629<sup>95</sup>****#SHPG14BDCHK, #SHPG14BDCKK, #SHPG14BDCMK****SHURE****PG Series****Dual Wireless Handheld Microphone and Lavalier Combo Kit****Kit Includes:**

PG24 Handheld Microphone System, PG4 Diversity Receiver, (2) PG-1 Body Pack Transmitter, (2) PG185-TQG Cardioid Condenser Lavalier, (2) GM-1W Wireless Mobile Pack, (2) 6ft XLR Cable, Pearstone Rapid AC Charger with 4 Rechargeable "AA" 2900mAh NiMh Batteries, (2) Micro Lavalier Clip Microphone Holder (Black)

**\$799<sup>95</sup>****#SHPG24BDCHK, #SHPG24BDCKK, #SHPG24BDCMK**



**SHURE**

**SLX/ULX Series**

The UA844 is a UHF antenna distribution system that allows the expansion of wireless microphone systems by splitting one pair of antennas to multiple receivers. A single UA844 system can support up to four wireless receivers.



- UA844US** Antenna power distribution system (470-900MHz) #SHUA844US ..... **\$344.95**
- UA440** 1/4 wave antenna (744-862MHz) #SHUA440 ..... **\$94.50**
- UA820C** (662-698MHz) #SHUA820C, **UA820D** (554-590MHz) #SHUA820D 1/2 wave antenna ..... **\$37.95**
- PA805WB** Passive directional antenna (470-870MHz) #SHPA805WB ..... **\$209.95**
- UA870WB** Active directional antenna (470-900MHz) #SHUA870WB ..... **\$239.95**
- UA221** Passive antenna splitter #SHUA221 ..... **\$119.95**
- UA830WB** In-Line RF amplifier (470-900MHz) #SHUA830WB ..... **\$139.95**
- UA507** Dual receiver 19" rack mount kit #SHUA507 ..... **\$29.95**

**SHURE**

**UHF/UHF-R Series**

The UA845 UHF Antenna Distribution System is designed for large UHF wireless systems. Each unit allows up to four wireless receivers to use the same two antennas, and the cascade ports allow connection to a fifth receiver or a second UA845. Whenever a signal is split to multiple output ports, there is a loss in signal strength. The UA845 amplifies signals to compensate, ensuring a strong signal to the receivers. Compatible with all Shure wireless microphone receivers operating within a compatible frequency range.



- UA845-US** Wideband UHF antenna (500-900MHz) #SHUA845US ..... **\$719.95**
- UA820A** (774-865MHz) #SHUA820UA, **UA820B** (692-746MHz) #SHUA820UB,
- UA820C** (662-698MHz) #SHUA820C, **UA820D** (554-590MHz) #SHUA820D - 1/2 wave antennas ... **\$37.95**
- PA805WB** Passive directional antenna (470-870MHz) #SHPA805WB ..... **\$209.95**
- UA870WB** (470-900 MHz) #SHUA870WB - Active directional antennas ..... **\$239.95**
- UA830WB** (470-900MHz) #SHUA830WB - In-Line RF amplifiers ..... **\$139.95**

**AUDIO TECHNICA**

**4000/5000 Series**

The AEWDA660D is a UHF active unity-gain antenna distribution system that provides two 1-in/4-out RF channels, and connects a pair of antennas to as many as four diversity receivers. A cascade output is provided as a directional coupler, and an AC pass-through allows daisy-chain AC hookup.



- AEW-DA660D** Antenna distribution system #AUAEWDA660D ..... **\$569.95**
- ATW-A49** Wide-band directional antenna (440-900MHz) #AUATWA49 ..... **\$252.50**
- ATW-A64P** Powered dipole antennas (655-681MHz) #AUATWA64P ..... **\$534.50**
- AT8628A** Dual receiver 19" rack mount kit #AUAT8628A ..... **\$18.95**
- ATWBH1** Antenna bulkhead connector kit #AUATWBH1 ..... **\$29.95**
- AC12** 12' BNC cable #AUAC12 ..... **\$19.95**
- AC25** 25' BNC cable #AUAC25 ..... **\$67.50**
- AC100** 100' BNC cable #AUAC100 ..... **\$202.95**

**ELECTRO-VOICE**

**RE-2 Series**

The APD4+ amplified antenna splitter makes it possible to operate four UHF wireless diversity microphone receivers on four separate frequencies using only two antennas. It also provides a high degree of output isolation, a necessity in multi-frequency systems to prevent intermodulation.

<b>APD4+</b> Antenna/power distribution system (600-780MHz) #ELAPD4.....	<b>\$399.00</b>
<b>LPA 500</b> Log Periodic antenna #ELLPA500.....	<b>\$239.00</b>
<b>ANU-14</b> 1/4 wave UHF antenna (668-746MHz) #ELANU14.....	<b>\$34.95</b>
<b>FA-500</b> 1/2 wave flexible antenna #ELFA500.....	<b>\$49.00</b>
<b>CLA-1</b> (520-565MHz) #TECLA1, <b>CLA-2</b> (565-615MHz) #TECLA2,	
<b>CLA-3</b> (615-660MHz) #TECLA3, <b>CLA-4</b> (660-690MHz) #TECLA4,	
<b>CLA-5</b> (690-752MHz) #TECLA5, <b>CLA-6</b> (725-760MHz) #TECLA6,	
<b>CLA-8</b> (798-865MHz) #TECLA8 - 1/2 wave colinear antennas .....	<b>\$81.00</b>
<b>UAA-500</b> UHF antenna amplifier #ELUAA500.....	<b>\$109.00</b>
<b>RM-D</b> Dual receiver 19" rack mount kit #ELRMD.....	<b>\$49.50</b>
<b>AB-2</b> Universal bracket for 1/2 wave antenna #ELAB2.....	<b>\$52.00</b>



**SENNHEISER**

**Evolution Wireless**

The ASP 2 is a Passive antenna RF splitter and DC distributor that allows a single pair of antennas to feed up to four EM 500 G2, EM 300 G2, or EM 100 G2 receivers. By combining two ASP 2's, an 8-channel system can be operated with only two antennas.\*



<b>ASP2</b> Passive antenna splitter and power supply #SEASP2.....	<b>\$448.95</b>
<b>S54378</b> 1/4 wave 7-section telescoping whip antenna #SES54378.....	<b>\$18.50</b>
<b>S72817</b> 1/4 wave 2-section telescoping whip antenna #SES72817.....	<b>\$12.50</b>
<b>A1031-U</b> Passive omnidirectional UHF antenna (430-960MHz) #SEA1031U.....	<b>\$139.95</b>
<b>A2003-UHF</b> Passive directional UHF antenna (450-960MHz) #SEA2003UHF.....	<b>\$266.50</b>
<b>AB2-A</b> Active antenna booster #SEAB2A.....	<b>\$183.50</b>
<b>AB2-B</b> Active antenna booster #SEAB2B.....	<b>\$183.50</b>
<b>AB2-C</b> Active antenna booster #SEAB2C.....	<b>\$183.50</b>
<b>AM2</b> Antenna mounting kit #SEAM2.....	<b>\$64.95</b>
<b>GA2</b> Dual receiver 19" rack mount kit #SEGA2.....	<b>\$67.95</b>

\*antenna splitter kits available

**AKG**

**WMS 4000 Series**

The PS 4000 is an antenna splitter for setting up UHF multichannel systems with up to four SR 4000 / SR 400 receivers per antenna splitter. It features two rear panel antenna inputs for connecting either SRA 1 passive antennas or SRA 2B or RA 4000 B active antennas with built-in boosters.



<b>PS 4000</b> Multi-coupler splitter (650-870MHz) #AKPS4000.....	<b>\$338.95</b>
<b>RA4000 B</b> Omnidirectional wide-band booster antenna (650-870MHz) #AKRA4000B.....	<b>\$129.95</b>
<b>SRA1</b> Passive, wideband directional antenna (680-945MHz) #AKSRA1.....	<b>\$214.50</b>
<b>AB4000</b> Antenna booster (650-870MHz) #AKAB4000.....	<b>\$176.50</b>
<b>ZAPD-21</b> Antenna combiner/splitter #AKZAPD21BNC.....	<b>\$108.50</b>
<b>ASU 4000</b> Remote power supply #AKASU4000.....	<b>\$166.95</b>

# ANTENNA KITS

These antenna kits are designed to eliminate the confusion involved in purchasing individual wireless components, offering the customer an expertly chosen out-of-the-box solution for multi-system wireless setups. The kits basically eliminate the forest of antennas associated with multiple receiver groups, and the single power distributor concept frees up electric outlets for other gear while powering multiple wireless systems. The result is cleaner reception and power, easier multi-system setup, and a completely professional appearance for either stage or installation applications.

## SENNHEISER

### Wireless Antenna and Power Distribution Splitter Kits

Sennheiser has created complete splitter kits for antenna and power distribution for their popular Evolution G2 wireless microphone series. The kits come in two varieties, one for front-mounting the antennas on a rack, the other for remotely mounting its omni-directional antennas. The kits are available in each of the A, B, and C frequency ranges.



#### Front Mounted Splitter Kit for 4 Sennheiser G2 Systems

<b>A frequency</b> #SEEWANT4FG2A.....	<b>\$897.95</b>
<b>B frequency</b> #SEEWANT4FG2B.....	<b>\$897.95</b>
<b>C frequency</b> #SEEWANT4FG2C.....	<b>\$897.95</b>

#### Remote Antenna Splitter for 4 Sennheiser G2 Systems

<b>A frequency</b> #SEEWANT4RG2A.....	<b>\$1139.95</b>
<b>B frequency</b> #SEEWANT4RG2B.....	<b>\$1139.95</b>
<b>C frequency</b> #SEEWANT4RG2C.....	<b>\$1139.95</b>



#### Front Mounted Splitter Kit for 8 Sennheiser G2 Systems

<b>A frequency</b> #SEEWANT8FG2A.....	<b>\$1399.95</b>
<b>B frequency</b> #SEEWANT8FG2B.....	<b>\$1399.95</b>
<b>C frequency</b> #SEEWANT8FG2C.....	<b>\$1399.95</b>

#### Remote Antenna Splitter for 8 Sennheiser G2 Systems

<b>A frequency</b> #SEEWANT8RG2A.....	<b>\$1642.50</b>
<b>B frequency</b> #SEEWANT8RG2B.....	<b>\$1642.50</b>
<b>C frequency</b> #SEEWANT8RG2C.....	<b>\$1642.50</b>



## SHURE

### HA-8089

The HA-8089 from Shure is a wide bandwidth helical antenna for use with UHF-R receivers, PSM transmitters, and antenna distribution systems for wireless mic and in-ear monitor systems. The additional 14 dBi of gain and wider beamwidth the HA-8089 provides results in a longer operating range for your systems, while depleting the likelihood of unwanted interference.

- 480 to 900 MHz bandwidth range
- Right angle female BNC connector
- 14 dBi of gain
- 50° beamwidth
- Clear polycarbonate construction
- 3 lbs, 14 x 14 x 14" shipping dimensions

#SHHA8089  
**\$449<sup>95</sup>**





**PSC**

**RF Antenna Distribution Amplifiers**

PSC offers a thorough range of antenna distribution amplifiers that cover all of the bases. In run and gun situations, the compact 1 x 4 RF Multi can run for 20 hours on two 9 volt batteries or run on AC power. If you need more flexible routing options and wide band capability, the RF Multi Dual 1 x 8 operates from 450Mhz to 900Mhz. With six sections and 48 BNC connectors, the RF MultiMax! offers total wide band control and flexibility.

- RF MultiMax!** 6 independent splitters in one for ultimate flexibility #PSRFMM..... **\$1895.25**
- RF Multi Dual 1 x 8** Two separate sections of active 1 x 8 splitters in one rack space #PSRFMD1X8..... **\$997.50**
- RF Multi** Portable battery powered 1 x 4 antenna distribution amplifier #PSRFMC1X4..... **\$460.75**



**SHURE**

**Wireless Antenna and Power Distribution Kits from B&H**

Piecing together a complete wireless antenna and power distribution system tends to be a little confusing. In order to simplify the process B&H has created these exclusive kits for Shure SLX and ULX systems. These kits greatly improve the efficiency and reliability of using multiple wireless microphone systems at the same time in one location. They also consolidate the number of antennas needed and eliminate most of the power cords.

- SUADP4** Complete Antenna and Distribution Package for up to 4 SLX and ULX Systems #SHSUADP4..... **\$959.95**
- SUADP7** Complete Antenna and Distribution Package for up to 7 SLX and ULX Systems #SHSUADP7..... **\$1299.95**
- SUADP10** Complete Antenna and Distribution Package for up to 10 SLX and ULX Systems #SHSUADP10..... **\$1649.95**



**AUDIO TECHNICA**

**Wireless Antenna and Power Distribution Kits for 2000/3000 Series Systems**

Putting together a complete wireless antenna and power distribution system tends to be a little confusing. To simplify the process B&H has created these exclusive kits for Audio Technica 2000 and 3000 series systems. These kits greatly improve the efficiency and reliability of using multiple wireless microphone systems at the same time in one location. They also consolidate the number of antennas needed and eliminate most of the power cords.



- 23ADP4** Complete Antenna and Distribution Package for up to 4 AT 2000 and 3000 Systems #AU23ADP4..... **\$744.95**
- 23ADP7** Complete Antenna and Distribution Package for up to 7 AT 2000 and 3000 Systems #AU23ADP7..... **\$1049.95**
- 23ADP10** Complete Antenna and Distribution Package for up to 10 AT 2000 and 3000 Systems #AU23ADP10..... **\$1364.95**

**1x ATW-DA49**  
**2x ATW-A49**

**2x ATW-DA49**  
**2x ATW-A49**

**3x ATW-DA49**  
**2x ATW-A49**

## InfraRed In the classroom

### Infra-red Wireless Systems for the Classroom

Infra-red wireless microphone technology has become an inexpensive and invaluable tool for use in classroom communications. Standard RF communications channels are saturated with cell phone, radio, television and emergency wireless activity in the VHF and UHF bands, often causing severe interference and drop-out. IR reception is impervious to this interference because it's in a completely different frequency range. IR wireless is by definition short-range, line-of-sight (think of your television or hi-fi IR remote) and doesn't penetrate walls – a perfect match for the classroom situation. In a school it is possible to operate multiple systems in adjacent classrooms without interference, and with dual-microphone wireless systems the soft-spoken kid in the back with a question can finally be heard clearly, the first time he asks.

#### AZDEN IR-CS

The IR-CS is a complete 2-channel infra-red wireless classroom communications and monitoring system. The components include the IRR-30P powered, dual channel receiver, the IRN-10 chest-worn microphone transmitter, the IRH-15c handheld microphone transmitter, the IRD-60 IR sensor, and a set of 4 ceiling-mounted ACS-6.5 speakers. Infra-red technology is an inexpensive method of providing localized wireless communication in the classroom, allowing for freedom of movement, complete class coverage, and more dynamic teacher-to-pupil interaction.

#AZIRCS  
**\$1007<sup>95</sup>**



- Complete infra-red wireless system for classroom or presentation room use
- Dual-channel IR receiver/ amplifier
- Handheld and chest-worn microphone transmitters

- Easily-mounted external IR sensor for optimal classroom coverage
- (4) ceiling-mounted speakers with 6.5" woofer and 1" tweeter
- Mounting brackets supplied



#### AZDEN IR-WS

The IR-WS is a complete dual-channel infra-red classroom communications and monitoring system. The components include the IRR-30P powered, dual channel receiver, the IRN-10 chest-worn microphone transmitter, the IRH-15c handheld microphone transmitter, the IRD-60 IR sensor, and a set of 4 wall-mounted AWS-4.5 speakers. Infra-red technology is an inexpensive and increasingly popular means of providing localized, line-of-sight wireless communication in the classroom or at the office, allowing for freedom of movement and clear, complete coverage of the class or audience.

#AZIRWS  
**\$923<sup>95</sup>**

- Complete infra-red wireless system for classroom or presentation room use
- Dual-channel IR receiver/ amplifier
- Handheld and chest-worn microphone transmitters

- Easily-mounted external IR sensor for optimal classroom coverage
- (4) wall-mounted speakers with 4.5" woofer, 1" tweeter, and .50" super-tweeter
- Mounting brackets supplied

#### CALIFONE CLS721-4

The CLS721-4 from Califone is a 4-person VHF wireless headphone listening system designed for classroom applications such as foreign language instruction. The system consists of a VHF transmitter in the 72.1 MHz range, 4 yellow color-coded wireless headphone receivers, an AC adapter, and a 6' audio cable connecting the transmitter to either a computer, multi-media player, or a television monitor. The system offers an effective transmission range of over 100'.

**CLS725-4** blue color-coded 72.5MHz version #CACL57254.....**\$149.95**  
**CLS729-4** green color-coded 72.9MHz version #CACL57294.....**\$149.95**  
**CLS721** yellow color-coded 72.1MHz headphones #CACL5721.....**\$49.95**  
**CLS725** blue color-coded 72.5MHz headphones #CACL5725.....**\$49.95**  
**CLS729** green color-coded 72.9MHz headphones #CACL5729.....**\$49.95**

#CACL57214  
**\$149<sup>95</sup>**

- VHF wireless headphone instructional listening system
- Over 100' transmission range
- Easily expanded for larger groups by adding additional headphones
- Headphones color-coded according to assigned VHF frequency
- Transmitter accepts input from virtually any audio source



Shown with optional cassette player and headphone rack

**ANCHOR AUDIO**  
**TOUR-60**

#ANTOUR60  
**\$1079<sup>95</sup>**

The TOUR-60 is a full six-user wireless tour guide system. It consists of a WB-6000 wireless beltpack transmitter paired with an HBM-60 headset microphone, and six AL-WB wireless beltpack receivers. Earbuds are included for use with each of the receivers. The system uses PLL synthesis for clear, stable audio transmissions. Each of the beltpacks runs on two AA batteries. The system offers a transmission range of up to 300', so listeners can wander away from a guide and still be able to hear everything. The headset has a cardioid microphone with a flexible boom arm for precise positioning.



- Full six-user system
- All beltpacks use AA batteries
- Includes earbuds, though standard jacks let you use any standard headphones
- Up to 300' line-of-sight range
- Cardioid microphone with flexible gooseneck boom



**WILLIAMS SOUND**  
**PFM300/350 Series**

Ideal for use in classrooms, lecture halls, and more, the PFM300 and PFM350 series of personal FM receivers provide high-quality audio in a compact and rugged design. The portable beltpack radio receivers have a range of up to 150' and can operate for up to 60 hours on standard AA batteries. Each receiver in the series uses a standard 3.5mm headphone jack, which allows you to use any set of headphones or earphones, an induction neckloop, or most T-coil equipped hearing aids.

- Compact and portable beltpack FM receivers
- Up to 150' range from transmitter
- Up to 60 hours of operation
- Uses standard AA batteries
- Standard 3.5mm headphone jack

<b>PFM300 [E]</b>	#WIPFM300E.....	<b>\$542.00</b>
<b>PFM300 [G]</b>	#WIPFM300G.....	<b>\$542.00</b>
<b>PFM350 [E]</b>	#WIPFM350E.....	<b>\$585.00</b>
<b>PFM350 [G]</b>	#WIPFM350G.....	<b>\$585.00</b>

**WILLIAMS SOUND**  
**WIR238**

#WIWIR238  
**\$151<sup>00</sup>**

The WIR238 is a perfect solution for wirelessly listening to your TV, CD player, or radio. The system consists of a slim transmitter, and a stethoset receiver. Simply connect the transmitter to the RCA audio outputs of your audio source. It wirelessly transmits the audio to the comfortable stethoset receiver. If your audio source does not have RCA outputs, you can place the included microphone near the speaker. The stethoset features comfortable earbuds, a large volume control, and separate tone and balance controls. The stethoset is easily recharged by docking it with the transmitter.

- RCA connection to a TV, CD player, and more
- Microphone included for sources with no RCA
- Up to 30' line-of-sight range
- Comfortable stethoset earbud receiver
- Independent volume, tone, and balance controls



**WILLIAMS SOUND**  
**IC-1**

#WIIC1  
**\$709<sup>95</sup>**

The IC-1 is a high-quality audio console for dual-language interpreter applications. It allows multiple interpreters to listen directly to an audio program, or to listen to another interpreter while speaking into a microphone at the same time. Multiple IC-1 units can be connected to handle applications with up to four languages. Standard 3.5mm and 1/4" mic connectors are provided, along with 3.5mm headphone jacks. A Williams Sound infra-red or FM listening system is required to use the IC-1.

- Support for dual-language applications
- Multiple units can be linked to support up to four languages
- Mic mute, relay, norm, and key controls
- Standard 3.5mm and 1/4" mic inputs
- 3.5mm headphone outputs
- XLR connectors for floor and relay in & key and norm out



**WILLIAMS SOUND**

**PPAVP**

Ideal for use in schools, theaters, houses of worship, and more, the PPAVP is a full four-user personal PA system. It consists of a slim base station transmitter and four beltpack receivers. The system has 17 user-selectable channels for clear, distortion-free audio. The transmitter accepts audio via the RCA or 3.5mm inputs, and transmits the audio wirelessly up to 500'. Each receiver has an ergonomic design and a large power/volume control. Each beltpack can operate for up to 100 hours on a pair of AA batteries. Standard 3.5mm headphone jacks are compatible with a variety of headphones and earbuds.

- Four-user FM personal PA system
- Slim base station transmitter can fit almost anywhere
- 17 user-selectable channels
- Up to 500' range
- Transmitter accepts mic and line-level signals



#WIPPAVP  
**\$867<sup>00</sup>**

- Receivers operate for up to 100 hours on two AA batteries



**WILLIAMS SOUND**

**PPA375**

Ideal for use in stadiums, theaters, auditoriums, and more, the PPA375 is a full four-user personal PA system. It consists of a base station transmitter and four beltpack receivers. The transmitter accepts audio via an XLR/TRS combo input, and transmits the audio wirelessly up to 500'. An RCA line output is provided for connecting a recorder or monitor. Each receiver has an ergonomic design and a large power/volume control. Each beltpack can operate for up to 100 hours on a pair of AA batteries. Standard 3.5mm headphone jacks are compatible with a variety of headphones and earbuds.

- Four-user FM personal PA system
- Base station transmitter with a large LCD screen
- XLR/TRS input and RCA line output on transmitter
- Up to 500' range
- Ergonomic receivers with 3.5mm headphone jacks
- Receivers operate for up to 100 hours on two AA batteries

#WIPPA375  
**\$935<sup>00</sup>**

- **PPA375PRO** Four-User Personal PA System with Headphones #WIPPA375P.....**\$1064.00**
- **PPA375-00** Four-User Personal PA System #WIPPA37500 .....**\$884.00**

**WILLIAMS SOUND**

**TGS100 One 2 One Series**

The TGS100 One 2 One series of tour guide systems are terrific tools for use in museums, cruise ships, universities, and more. The system can support up to six wireless listeners, and includes one beltpack transmitter and six beltpack receivers. The wireless range of the system is approximately 300', and each of the beltpacks can operate for hours using standard AA batteries. The transmitter has a standard 3.5mm mic input for connecting the included headband microphone, or other standard mics. The receivers have 3.5mm headphone outputs for connecting the included headphones, or any other standard headphones or earbuds.

**\$1254<sup>00</sup>**



- Channel E** 216.325MHz #WITGS100E
- Channel G** 216.425MHz #WITGS100G
- Channel J** 216.625MHz #WITGS100J
- Channel L** 216.725MHz #WITGS100L

- Full six-user wireless tour guide system
- Slim and durable beltpack transmitter and receivers
- Up to 300' range
- Uses standard AA batteries
- Microphone and headphones included
- System carrying case included



**WILLIAMS SOUND**

**TGSPRO720**

#WITGSP720  
**\$1330<sup>00</sup>**

The TGSPRO720 is a complete 10-user wireless FM tour guide system that's ideal for use in museums, cruise ships, universities, and more. The system includes a beltpack transmitter with a headband microphone, 10 beltpack receivers, enough AA batteries to power the beltpacks, and a carrying case. The system's operating range is approximately 150'. Each of the beltpacks has a slim, ergonomic design with easy-to-use controls. Standard 3.5mm headphone jacks allow you to use a variety of headphones or earphones.

- Standard 3.5mm mic and headphone connectors
- Up to 100 hours of operation on two AA batteries
- Up to 150' operating range
- Ergonomic beltpacks with intuitive controls
- Batteries and carrying case included

**CALIFONE**  
**P130-IRSYS**

The P130-IRSYS is a complete infra-red wireless audio system designed for classroom or presentation room use. It's designed much like a portable P.A. system, easy to use and set up, and includes a tamper-proof metal storage case. The system consists of a pair of ceiling-mounted IR receivers (sensors), two passive 3-way array-type speakers, a receiver amplifier, and wireless handheld and headset microphones for clear teacher/pupil Q&A.

- Self-contained classroom IR wireless P.A. system with storage case
- Dual wireless microphone transmitters and dual ceiling mount IR sensors
- Mixer and amplifier with separate mic controls and tone controls
- XLR wired mic and Hi-Z instrument inputs
- Dual field-array speakers with 3 Neodymium magnet-equipped speakers
- Focused sound with even dispersion for speakers

#CAP130IRSYS  
**\$950<sup>00</sup>**



**SENNHEISER**  
**SET 100**

The SET 100 is an infra-red assistive-listening wireless system for televisions consisting of the TI 100 mono transmitter and an RI 100-A monophonic stethophone receiver. The system transmits and receives on the 95kHz IR carrier frequency. The transmitter connects directly to the output of a standard TV or VCR (Plasma TV's are not compatible) and the receiver is equipped with a volume knob and balance and tone controls.

- Monophonic infra-red assistive-listening system for TV's and VCR's
- 435 sq.ft. area coverage
- 95kHz carrier frequency
- Stethophone receiver with latex ear cushions
- RCA and 1/8" mini plug connectors
- Rechargeable battery

#SESET100  
**\$183<sup>50</sup>**

**SET250** 2.4MHz dual battery version #SESET250.....**\$227.95**

**SENNHEISER**  
**SET 810**

The Sennheiser SET 810 is an infrared personal listening system, available in 2.3 or 2.8MHz frequencies, for use with televisions and hi-fi audio systems. The lightweight, adjustable stethoset headphone receiver features a compression driver for consistent playback level and optimized speech intelligibility, and a volume knob. The base transmitter covers a 600 sq.ft. area, with a 40' transmission range, and includes a charging cradle with a spare battery compartment.

- Infra-red personal listening system for televisions with stereo/mono switching
- Adjustable stethoset headphones with volume control
- Auto on/off function, rechargeable receiver battery
- Transmitter with charging cradle, spare battery compartment
- Includes microphone for connection to TV's without audio outputs

#SESET810  
**\$227<sup>95</sup>**



**SET820** black/blue version w/switchable compressor #SESET820.....**\$264.95**



**SENNHEISER**  
**SET 810S**

The Sennheiser SET 810S is an infrared television and hi-fi assistive-listening system designed for use with hearing aid accessories such as induction neck loops and silhouettes. The lightweight bodypack receiver features a compression driver, for consistent playback level and optimized speech intelligibility, as well as a large, easy access volume control knob. The base transmitter covers a 600 sq.ft. area, with a 40' transmission range, and a charging cradle with a spare battery compartment.

- Infra-red assistive-listening system for televisions
- Bodypack receiver neck loop and silhouette audio connectors
- Direct audio input from behind-the-ear hearing aid for receiver
- 2.3 and 2.8 MHz frequency versions
- Stereo or mono operation
- Transmitter includes charging cradle and spare battery compartment

#SESET810S  
**\$247<sup>95</sup>**

**SET820S** black/blue version w/switchable compressor #SESET820S.....**\$264.95**

## NEUMANN KMS105MT

(Black)

#NEKMS105MT  
**\$649<sup>99</sup>**

Bringing Neumann studio quality onto the stage, the KMS105 is a precision-engineered supercardioid handheld condenser microphone that delivers the transparent, detailed performance characteristics required by professional vocalists.

- Transformerless output provides excellent clarity and minimal distortion
- 48V phantom powered
- Rugged steel basket and chassis construction
- 150dB SPL
- 20Hz-20kHz frequency response
- Padded nylon and stand clamp (included)



## SHURE KSM9

#SHKSM9CG  
**\$699<sup>00</sup>**

The KSM9 captures vocal subtlety with extraordinary detail to deliver clear articulation, functional flexibility and precise vocal reproduction for live performance. It exhibits exceptional consistency across all frequencies, providing more gain before feedback, while decreasing proximity effect. With its dual-diaphragm design and switchable polar patterns, this mic is the perfect choice for demanding vocal performances.

- High-performance handheld condenser
- Switchable supercardioid/cardioid polar patterns
- Advanced suspension shock mount
- 50Hz to 20kHz frequency response
- Includes aluminum carrying case

**Champagne-color version #SHKSM9SL \$699.00**

## SHURE SM86

#SHSM86  
**\$179<sup>00</sup>**

Delivering tried-and-true quality at an attractive price, the Shure SM86 is the cardioid condenser relative to the famous SM58. Tailored for live vocal performances, the SM86 combines a wide frequency response and excellent gain before feedback with the tonal characteristics and proven reliability musicians have come to expect from Shure.

- Cardioid polar pattern reduces unwanted background noise
- 48V phantom powered
- Rugged construction ideal for touring situations
- Internal shock mount and two-stage pop filter reduce handling and wind noise
- Sturdy microphone clip and zippered pouch (included)
- 124dB SPL
- 50Hz-18kHz frequency response



## SHURE BETA 87A

#SHBETA87A  
**\$249<sup>00</sup>**

Tailored especially for vocals, the accurate and detailed BETA 87A is a high-quality, supercardioid condenser microphone designed to reproduce all the musical nuances of the live stage performance. Shure has redesigned this microphone by just slightly thickening the handle for a more comfortable feel when hand-held.

- Smooth, rich response
- Ruggedly built for touring
- High gain before feedback
- 48V phantom powered
- Includes the A25D break-resistant swivel adapter
- 140dB SPL
- 50Hz-20kHz frequency response

**Beta 87C** cardioid version of Beta87A

#SHBETA87C ..... **\$249.00**

## AUDIX VX10

#AUVX10  
**\$479<sup>00</sup>**

The high quality Audix VX10 is a natural and detailed cardioid condenser microphone that's ideal for live stage performances. Its smooth uniform response covers a wide frequency range with amazing clarity and realism. It features a 16mm gold vapor diaphragm, a steel mesh grille screen, and the Audix trademark black satin finish.

- Rich sonic clarity in low-mid frequencies
- Extremely versatile in vocal and acoustic instrument applications
- Low-handling noise
- Includes: foam lined wooden carrying case, pouch, mic stand adapter, and external foam windscreen
- Requires phantom power
- 140dB SPL
- 40Hz-20kHz frequency response





**AKG**  
**Elle C**

Ideal for both studio and live performance, the AKG Elle C is a professional handheld cardioid condenser microphone tailored to precisely reproduce the natural tonal characteristics of the female voice. Its elegant in design provides a steel wire-mesh grill and internal elastic suspension, resulting in greater ruggedness and reduced handling noise.

- Professional handheld cardioid condenser microphone
- Highly-detailed response tailored for female vocals
- Steel wire-mesh grill and internal suspension
- 9-52v phantom power required
- 60Hz-20kHz frequency range

**Elle C in silver** #AKELLECS ..... **\$249.00**  
**Elle C in white** #AKELLECW ..... **\$249.00**



**AUDIX**  
**OM7** #AUOM7  
**\$229.00**

The ruggedly built Audix OM7 is a high-quality hypercardioid dynamic microphone that's popular among live PA and touring sound engineers. Its controlled low-gain output stage allows it to handle high volume sources producing a natural, detailed sound, while the extremely tight pickup pattern delivers the accuracy and high gain before feedback required by many of today's aggressive vocalists.

- Natural, detailed characteristic
- Provides exceptionally high gain before feedback
- Low-handling noise
- Dent resistant steel grille
- Mic stand adapter and zippered pouch (included)
- 144dB SPL
- 48Hz-19kHz frequency response



**SHURE**  
**Beta 58A**

Tailored for vocals, the well-built Shure Beta 58A is a supercardioid version of the famous dynamic SM58 microphone. Its smooth, extended frequency response and clean high-output detail deliver the desired sound for both live and studio performances.

- Neodymium magnet for high signal-to-noise output
- Bass roll-off for controlled proximity effect
- Supercardioid polar pattern provides high gain-before-feedback
- Ideal for lead, backup vocals, and spoken word
- 50Hz-16kHz frequency response



#SHBETA58A  
**\$159.00**

**SHURE**  
**SM58-LC**

The Shure SM58 is the world's most widely-used dynamic cardioid microphone. Its legendary reliability, dependability, and near indestructibility have made it the preferred choice of both musicians and engineers for a multitude of "live" and studio vocal applications.

- Frequency response tailored for vocals
- Pneumatic shock-mount system cuts down handling noise
- Effective, built-in spherical wind and pop filter
- Includes break-resistant stand adapter that rotates 180 degrees
- Unidirectional cardioid pickup pattern isolates desired source from unwanted background noise
- 50Hz-15kHz frequency response

**SM58CN** dynamic cardioid mic with 25ft XLR cable #SHSM58CN..... **\$109.00**

**SM58S** dynamic cardioid mic with on/off switch #SHSM58S..... **\$104.00**



#SHSM58LC  
**\$99.00**

**ELECTRO-VOICE**  
**N/D767A**

Designed with the professional stage vocalist in mind, the EV N/D767A is a premium quality, supercardioid dynamic microphone with superior feedback rejection, extremely low handling noise and a high output Neodymium element that gives you the clarity and detail you need. Electro-Voice's VOB technology counteracts the tendency of most microphones to get "muddy" and "boomy" by reducing unwanted resonant peaks in frequency response.

- Supercardioid polar pattern
- Warm-Grip handle for comfort and lower handling noise
- High gain before feedback
- Multi-stage shock mount
- Patented low-frequency roll-off filter
- 70Hz-22kHz frequency response

#ELND767A  
**\$129.00**



## AKG C535 EB

#AKC535EB  
**\$299<sup>00</sup>**

The C 535 EB is a handheld cardioid condenser microphone with many of the characteristics of AKG's best studio condensers. It has a slight 2dB rise in the 7-12 kHz range, giving vocals added presence. A four-position switch on the mic provides a useful combination of output and low frequency level contours.

- Versatile cardioid condenser
- Operates on phantom powering from 9-52 Vdc
- 4-position switch tailors output level and bass response
- 137dB SPL
- Includes SA41/1 stand adapter
- 20HZ-20kHz frequency response



## AUDIO TECHNICA MB4K

#AUMB4K  
**\$89<sup>95</sup>**



The Midnight Blues Series MB4K is a handheld cardioid condenser designed for studio-quality vocal and instrument applications at a low price. This price/performance leader features: battery/phantom operation, an on/off switch, rugged all-metal construction, soft-touch finish, and extended response for smooth, natural sonic characteristics.

- Affordable, studio-quality handheld microphone
- Battery/phantom operation for maximum versatility
- Corrosion-resistant, gold-plated XLRM-type connector
- Extended response for smooth, natural sonic characteristics
- Includes: AT8405a stand clamp, 5/8"-27 to 3/8"-16 threaded adapter, and soft protective pouch
- 137dB SPL
- 80Hz-20kHz frequency response

## AKG D5

#AKD5  
**\$99<sup>00</sup>**

The D5 is a dynamic vocal microphone for the stage with a super-cardioid pickup pattern. The capsule is equipped with an internal dual-shockmount that minimizes handling noise, and the tight polar pattern effectively eliminates off-axis noise and feedback problems.

- Super-cardioid handheld dynamic stage microphone
- Patented Varimotion diaphragm for enhanced vocal reproduction
- Shock capsule for enhanced protection from handling noise
- Steel wire-mesh grill
- Matte grey-blue finish
- 147dB SPL handling
- 70Hz-20kHz frequency response
- Includes SA45 microphone adapter and carrying bag



## ELECTRO-VOICE N/D 967

#ELND967  
**\$199<sup>00</sup>**



The N/D967 is a supercardioid dynamic microphone designed for high gain-before-feedback performance and extremely low handling noise. Ideally suited for live vocals, the N/D967 features an optimized neodymium alloy magnet for enhanced output sensitivity, superior multistage shock mounting, and a unique removable front grille assembly and pop filter for easy cleaning. The N/D 967 also uses a humbucking coil to cancel hum from lighting and power sources.

- Optimized response for live performance
- Ultra-High gain before feedback
- EV-exclusive personality switch shapes sound
- "Warm Grip" handle provides comfortable feel
- Includes: stand adapter and zippered case
- 50Hz-13kHz frequency response

## BEHRINGER UltraVoice XM8500

#BEXM8500  
**\$199<sup>99</sup>**

The UltraVoiceXM8500 is a handheld cardioid dynamic vocal microphone with excellent sound rejection from the rear and sides, making it less prone to feedback. It features a smooth mid-frequency presence, internal shock mounting to reduce handling noise, a two-stage pop filter, and a tough steel mesh windscreen.

- Dynamic vocal microphone with smooth mid-frequency presence
- Cardioid characteristic minimizes background noise and feedback
- Super-rugged, reliable metal construction and electromagnetic shielding
- Two-stage pop filter minimizes breath and pop noises
- High-level balanced output
- Low distortion for a super-clean sound
- Includes stand adapter
- 50Hz-15 kHz frequency response



**M-AUDIO****Aries**

The Aries is a professional cardioid condenser microphone designed for stage/live sound applications. M-Audio's proprietary internal shock-mounting technology allows the Aries to deliver studio-quality fidelity while minimizing handling noise. Its cardioid polar pattern rejects background sound and minimizes feedback while handling the high SPL's of concert environments.

- Studio-quality condenser
- Class-A FET electronics provide high output and low noise
- Internal shock mount minimizes handling noise
- Integrated internal pop filter minimizes wind and pop noises
- Solid brass capsule with evaporated gold diaphragm
- Includes: stand mount and vinyl carrying case
- 134dB SPL
- 20Hz-20kHz frequency response

#MAACM  
**\$169<sup>00</sup>**

**SAMSON**  
**Q7**

The Q7 is a Samson's top-of-the-line Neodymium handheld dynamic microphone designed for live performance and studio applications. Its tight supercardioid pattern has excellent off-axis rejection, minimizing feedback problems and background noise. The Q7's internal shock mount helps reduce handling noise and protects the microphone element from the rigors of stage use .

- Supercardioid handheld microphone
- Neodymium dynamic mic element for high output gain
- Multi-axis, shock-mounted element
- Two-stage internal pop filter
- Includes stand adapter and carrying case
- High SPL response
- 80Hz-12kHz frequency response

#SAQ7  
**\$89<sup>00</sup>**

**SHURE**  
**55 SH/II**

The 55 SH/II cardioid dynamic microphone provides the Shure classic UNIDYNE II design coupled with modern acoustic components to meet today's performance standards. It is ideal for public address, theater/stage sound systems, or other sound applications where a stand-mounted microphone with a classic look is desirable.

- Classic appearance, modern performance
- Frequency response tailored for speech, vocals and instrumental music
- Shock-mounted cartridge minimizes stand-transmitted noise
- Self-tensioning swivel mount, Built-in ON/OFF switch • 50Hz-15kHz

#SH55SH2  
**\$167<sup>95</sup>**

**SENNHEISER****MD 431-II**

The MD 431-II is a top-quality supercardioid dynamic microphone designed for live vocals. A nearly frequency-independent polar pattern offers incredibly high gain before feedback and provides uncolored off-axis response. It features a noiseless, magnetic reed on/off switch that is recessed in its handle, and has internal electronics for refining its proximity effect.

- Dynamic, supercardioid stage vocal mic
- Exceptional feedback rejection
- Hum compensating coil reduces electrical interference
- Integral pop filter
- Includes MZA 4031 stand adapter
- 40Hz-16kHz frequency response

#SEMD4312  
**\$429<sup>50</sup>**

**SHURE**  
**PG58 (XLR)**

The PG58 is a cardioid dynamic microphone tailored to accentuate the clarity of lead and back-up vocals. This attractively-priced microphone picks up the most sound from in front of the microphone, and some sound from the sides, making it less susceptible to feedback in high-volume settings.

- Neodymium magnet for high output level
- Internal shock mount for reduced handling noise
- Hardened steel mesh ball grille that resists wear and abuse
- Integral "pop" filter
- Includes: 15-ft. cable, stand adapter, and storage bag • 60Hz-15kHz

#SHPG58XLR  
**\$59<sup>00</sup>**





**BEYERDYNAMIC****M 88 TG**

The M 88 TG's hypercardioid pickup pattern and high sound pressure rating make it an ideal choice for a wide variety of vocal applications where off-axis rejection is paramount. Its extended frequency range gives this dynamic mic an accurate response with exceptional bass reproduction, perfect for voice, kick drums, and other high output instruments.

- Dynamic, hypercardioid handheld microphone
- Allows high volume before feedback
- Known choice for voice, kick drums and woodwinds
- Fast response for accurate transient reproduction
- Includes: microphone clamp and storage bag
- 30Hz-20kHz frequency response



#BEM88TG  
**\$399<sup>00</sup>**

**EARTHWORKS****SR20**

The SR20 is a cardioid condenser performance microphone that is marked by its clean on-axis pickup and smooth uncolored off-axis response. It will accurately capture a voice with the same precision and quality up to 90 degrees off-axis, giving users the same pristine sound quality at the front and side of the microphone. The forgiving yet highly intelligible quality of this mic make it superb for vocals and spoken word. A removable windscreens allows the SR20 to be used to capture choirs, musical instruments, and amplifiers.

- Condenser, cardioid performance mic
- Forgiving uniform off axis response
- Highly intelligible with low handling noise
- Removable windscreens assembly
- 50Hz to beyond 20kHz frequency response



#EASR20B  
**\$619<sup>00</sup>**

**BEYERDYNAMIC****Opus 69**

The Opus 69 is a supercardioid handheld dynamic vocal microphone that offers comfortable handling, rugged construction, and a sleek design. This mic has the ability to withstand high sound pressure levels, making it suitable for the close miking of musical instruments or speaker cabinets. Its tight pattern helps to suppress feedback and reject other instruments on stage, producing a rich, clear signal that lets you concentrate on your vocal performance.

- Dynamic, supercardioid handheld microphone
- Excellent isolation of unwanted sound
- Aluminum shaft with matte black finish
- Includes: mic clamp and storage bag
- 35Hz-16kHz frequency response



#BE069  
**\$199<sup>00</sup>**

**RODE****S1**

The Rode S1 is designed specifically for "no compromise" live vocal performance, but has also found a place in the studio where the performer wishes to hold the mic during recording for a more dynamic performance. This supercardioid condenser features a sophisticated high-pass filter to dramatically reduce undesirable low-frequency background and handling noise. The multi-stage mesh head filters breath, wind, and plosive noise without affecting sensitivity or frequency response.

- Condenser, supercardioid handheld mic
- Attractive satin-nickel finish with ergonomic design
- Rugged all-metal construction and low handling noise
- Custom designed integral "plosive" screen
- Ergonomically weighted and balanced
- 20Hz to 20kHz frequency response



#ROS1  
**\$299<sup>00</sup>**

**SENNHEISER****e840**

Designed to cut through high on-stage sound levels, the e840 is fitted with a hum-compensating coil to help reduce electromagnetic interference. It efficiently suppresses sounds emanating from outside its pickup angle while providing the performer with a predictable and easy-to-control response. The e840's internal shock mounting prevents handling noise and damage to the microphone element when accidentally dropped or hit on stage.

- Cardioid, dynamic stage mic
- Excellent vocal projection
- Highly insensitive to feedback
- Frequency-independent directivity
- Includes: MZQ mic clamp and protective carrying pouch
- 40Hz-18kHz frequency response



#SEE840  
**\$129<sup>99</sup>**

**SENNHEISER****e835**#SEE835  
**\$99<sup>99</sup>**

The e835 is a dynamic vocal stage mic designed with a uniform frequency pick-up pattern that maintains its signal quality when moving on and off axis during performance. This cardioid mic features a gentle presence boost to even out tonal response, ensuring clarity and projection under demanding stage conditions. Its minimal proximity effect provides consistently clear bass with intelligible performance whether singing closer to or further from the capsule.

- Cardioid, dynamic handheld stage mic
- Rugged and reliable metal construction
- Shock-mounted capsule
- Includes: protective pouch and microphone clip
- 40Hz-16kHz frequency response

**Threepack 835** pack of (3) mics, clips and pouches #SEE8353K... **\$119.99**  
**e835-S** same model with silent on/off switch #SEE835S..... **\$109.00**

**AUDIX**  
**OM5**#AUOM5  
**\$159<sup>00</sup>**

The OM5 is a dynamic vocal microphone that is highly regarded by artists and engineers for its ability to produce quality sound at very high sound pressure without distortion or feedback. It is naturally attenuated at 120Hz to reduce boominess and handling noise, and the mid-range is tailored for clarity and presence (making it easier for the vocals to be heard both in the mains and monitors).

- Dynamic, hypercardioid performance microphone
- Very Low Mass capsule technology yields exceptional transient response
- Durable construction with a dent-resistant spring steel grill
- Includes: clip and zippered microphone carry pouch
- 48Hz-19kHz frequency response

**SENNHEISER****e845**#SEE845  
**\$139<sup>99</sup>**

Extended high frequency response and a supercardioid pick-up pattern give the e845 the ability to deliver smooth warm tonal characteristics and an extended dynamic range at higher volumes. It's consistent on/off axis and proximity response help to maintain even sound quality while moving, providing greater on-stage freedom. The full metal construction and extensive internal shock mounting make this performance mic a top choice for stage use.

- Supercardioid, dynamic performance mic
- Metal construction means greater durability
- Hum compensating coil reduces interference
- Full dynamic range with excellent signal quality
- Superior magnet keeps mic stable regardless of climate
- 40Hz-16kHz frequency response

**e845-S** same model with silent on/off switch #SEE845S..... **\$149.99**

**AUDIX**  
**OM2**#AUOM2  
**\$99<sup>00</sup>**

The OM2 is a hypercardioid dynamic live performance mic with a transformerless design, ideal for vocals, spoken word, and instrument miking. It has the same well-balanced, comfortable profile as Audix's high-end touring vocal mics, and features a low reflective black e-coat finish, a dent-resistant spring-steel grille, and sound pressure handling capabilities in excess of 140dB.

- Dynamic, hypercardioid handheld mic
- Equally usable on vocal artists, spoken word, and instruments
- Great for coffeehouses, small-to-medium clubs, and outdoor festivals

- Exceptional performance at a breakthrough price
- 50Hz-16kHz frequency response

**OM2-s** same model with on/off switch  
 #AUOM2S ..... **\$119.00**

**SENNHEISER****e865**#SEE865  
**\$269<sup>95</sup>**

The e865 is a lead vocal condenser microphone designed for live performance applications. Its smooth supercardioid polar pattern rejects feedback with low, off-axis coloration, and its well-designed element withstands sound pressure levels of up to 150 dB. This rugged mic provides detailed 40Hz-20kHz reproduction, superb transient response, and an all-metal housing with a steel grille.

- Supercardioid, condenser professional stage mic
- Rugged, robust all-metal housing and steel grille
- Comfortable, ergonomic design with responsive performance
- Includes mic clip and protective pouch
- 40Hz-20kHz frequency response

**e865-S** same model with silent on/off switch #SEE865S... **\$279.00**



**CAD  
22A**#CACAD22A  
**\$31<sup>95</sup>**

The 22A is a dynamic cardioid microphone designed with professional qualities in mind but priced for the budget-conscious vocalist and musician. It features a frequency response covering the audible range necessary for accurate natural sound, and a uniform cardioid polar pattern that reduces annoying feedback when used in close proximity to sound reinforcement speakers and monitors. Also, the built-in presence boost provides the additional "punch" needed in sound reinforcement.

- Cardioid, dynamic handheld mic
- On/off switch with recessed button
- Die-cast zinc alloy housing with "soft feel" finish
- Multi-stage blast filter minimizes wind and breath noise
- 60Hz-15kHz frequency response

**25A** supercardioid, 50Hz-16kHz version #CACAD25A..... **\$44.95**

**SENNHEISER  
e935**#SEE935  
**\$169<sup>00</sup>**

The e935 is a very durable dynamic microphone with a high signal output and dependable construction for many hours of hard stage use. Its cardioid pickup pattern provides both insulation from other on-stage sounds and a forgiving response for the performer. Built for excellent results day in and day out, this microphone was made for the working musician who needs a mic that's rugged and can endure long hours of live performance.

- Cardioid, dynamic stage mic
- Low sensitivity to impact and handling noise
- High signal output helps cut through the mix
- All-metal construction is rugged and reliable
- 40Hz-16kHz frequency response

**CROWN  
CM-200A**#CRCM200A  
**\$259<sup>95</sup>**

The Crown CM-200A is a cardioid condenser microphone designed for professional vocal and instrumental use. It offers studio quality sound, yet is rugged enough to withstand hard professional use in the field. An upper midrange "presence peak" adds intelligibility and an added boost to help cut through any stage mix. This outstanding performance mic is complemented with handsome styling and a comfortable balance along with a wide frequency range and smooth response.

- Cardioid, condenser handheld vocal mic
- Unidirectional polar pattern reduces feedback and background noise
- Rugged aluminum housing with steel grill
- Foam windscreen to reduce popping and wind noise
- 80Hz-15kHz frequency response

**CM-200ASW** same model with on/off switch #CRCM200ASW..... **\$299.50**

**CAD  
C195**#CAC195  
**\$99<sup>99</sup>**

The wide and flat frequency response of the C195 gives it a natural transparent sound while the cardioid pickup pattern minimizes annoying feedback and reduces the pickup of unwanted off-axis sounds. A transformerless electronic design provides optimal low frequency response and low distortion. Its "Flex-Form" hardened steel grille screen adamantly retains its shape while it greatly reduces any risk of adverse performance caused by a bent or dented ball screen.

- Cardioid, dynamic handheld stage mic
- Internal shock mounting reduces handling noise
- Internal multistage pop filter and steel grille
- Supplied with zippered pouch and swivel mount
- 50Hz-18kHz frequency response

**D189** supercardioid, neodymium 50Hz-16kHz version #CAD189..... **\$89.99**

**AUDIO-TECHNICA  
MB 1k/c**#AUMB1KC  
**\$44<sup>50</sup>**

A perfect introductory performance mic, the high-output MB 1k/c is designed for lead, backup, or choral vocals. Supplied with a 15-ft. cable, it features a neodymium magnet structure for maximum output and fast transient response, lockable switch design for silent on/off operation and a corrosion-resistant, gold-plated XLR connector. Its velvety finish provides a secure, comfortable grip and the ultra-soft-touch surface minimizes mechanical noise.

- Cardioid, dynamic handheld performance mic.
- Rugged all-metal construction with silent on/off switch
- Reduced handling noise with anti-shock engineering
- High-output design allows vocals to cut through the mix
- Includes 15-ft. cable and stand clamp
- 80Hz-12kHz frequency response





**AUDIO-TECHNICA****ATM410**#AUATM410  
**\$99<sup>00</sup>**

This cardioid dynamic workhorse is designed for smooth, natural vocal reproduction and low noise. Equipped with a neodymium magnet for high output and a multi-stage grille design for excellent protection against plosives, the ATM410 is built to stand up to life on the road. Its cardioid polar pattern reduces pickup of sounds from the sides and rear, maximizing isolation from other sound sources and minimizing feedback.

- Cardioid, dynamic performance mic
- Excellent off-axis rejection for minimum feedback
- Multi-stage grille offers excellent protection against plosives
- Rugged, all-metal design and construction for years of trouble-free use
- 90Hz-16kHz frequency response

**SAMSON****R11**#SAR11Q  
**\$23<sup>00</sup>**

The R11 is an affordable dynamic mic ideal for vocal performance, karaoke, public speaking, and DJ. It features a hypercardioid polar pattern for maximum feedback rejection and a neodymium magnet for the higher output required in today's live performance applications. It is equipped with a conveniently placed on/off switch, and a triple-plated multi-stage windscreen and noise filter that removes pops, sibilance, and onstage noise.

- Dynamic with a hypercardioid polar pattern
- Transformerless design with low impedance voice coil
- Neodymium magnet for high output
- Multi-axis shock mount to minimize handling noise
- Neoprene transformer cover for the reduction of microphonics
- 50Hz-15kHz frequency response

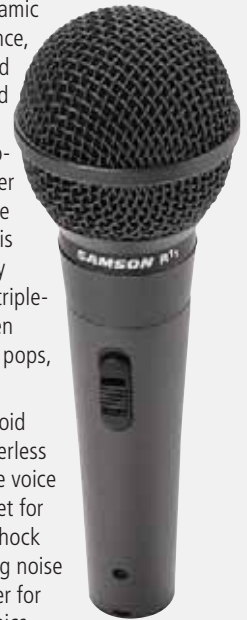
**R11** three-pack containing (3) R11's#SAR11.....**\$69.00****AUDIO-TECHNICA****ATM610**#AUATM610  
**\$139<sup>00</sup>**

Tuned for clear, detailed, extended-range reproduction of lead and backup vocals, the ATM610 dynamic vocal mic is equipped with a rare earth neodymium magnet, a tight hypercardioid polar pattern, and multi-stage grille design. The microphone features an innovative dual-wall floating construction; the back-cavity assembly "floats" inside the handle shell, providing outstanding isolation from handling noise.

- Hypercardioid, dynamic handheld stage mic
- Tight polar pattern helps isolate performer and reduce feedback
- Corrosion-resistant contacts from gold-plated XLR connector
- Includes Quiet-Flex stand clamp for flexible microphone positioning
- Clear sound, rock-solid durability, and aesthetic design
- 40Hz-16kHz frequency response

**SAMSON****Q8**#SAQ8  
**\$129<sup>00</sup>**

The Q8 is a handheld dynamic microphone designed for both live performance and recording applications. Extremely sensitive, it employs a tight super-cardioid pattern to reduce feedback and is capable of handling audio signals with high sound pressure levels. The versatile Q8 is well suited to a wide variety of vocal and instrumental tasks on stage and in the studio.

- Supercardioid, dynamic mic geared for live performance
- Excellent on vocals, acoustic instruments, percussion and amplifiers
- Rejects signals not originating from directly in front of the mic capsule
- Includes: mic stand clip and carry case
- 50Hz-16kHz frequency response

**AUDIO-TECHNICA****ATM710**#AUATM710  
**\$169<sup>00</sup>**

With its remarkable clarity, the ATM710 condenser microphone is designed for studio-quality performance on stage. It is equipped with an integral 80Hz hi-pass filter that provides easy switching from a flat frequency response to a low-end roll-off position that reduces the microphone's sensitivity to popping in close vocal use. The ATM710 is also equipped with a switchable 10 dB pad that lowers the microphone's sensitivity, providing higher SPL capability.

- Cardioid, condenser stage mic
- Excels in venues with controlled stage volume or in-ear monitoring
- Condenser design for studio-quality performance
- Integral 80 Hz HPF switch and 10 dB pad
- 40Hz-20kHz frequency response



**AUDIX****D4**

The Audix D4 is a hypercardioid dynamic microphone that utilizes an entirely new capsule specially designed to capture high SPL instruments with extended frequencies below 100Hz. Ideal for stage or studio use, the D4 captures a truer image of the original sound than previous generation kick drum mics. It has a flat response down to 63 Hz, with a slight bump at 80Hz, and a gentle roll-off below 40Hz.



- Compact design great for close microphone placement
- Excellent gain before feedback
- Zippered pouch and stand adapter (included)
- 144dB SPL • 38Hz-19kHz frequency response

**ELECTRO-VOICE****N/D468**

Designed primarily for use on instruments, the Electro-Voice N/D468 is a supercardioid dynamic microphone capable of handling high SPL's while delivering smooth and accurate audio. Its unique pivoting head and functional design ensures audio engineers the best possible microphone placement on percussion, horns, and both acoustic and electric guitars.

- High-output Neodymium mic capsule
- Durable non-reflecting black finish
- Supercardioid pattern effectively rejects background noise
- Superior high-level handling
- Zippered pouch and stand adapter (included)
- 30Hz–22kHz frequency response

#ELND468  
**\$199.00**

**SHURE****SM57-LC**

The Shure SM57 is the industry standard instrument microphone. Its legendary versatility and durability earned it the worldwide reputation as a stage and studio workhorse.



- Frequency response contoured for clean instrument reproduction
- Unidirectional cardioid pickup pattern isolates desired source from unwanted background noise
- Excellent for snare drums, guitar/bass amps, brass and other high SPL sound sources
- Pneumatic shock-mount system cuts down handling noise
- 40Hz–15kHz frequency response

**BLUE****Ball**

Striking in appearance and revolutionary in operating principal, the Ball is a high-quality, cardioid, phantom-powered dynamic microphone featuring Blue's Class-A discrete low noise amplifier circuitry. Its smooth frequency response and rich tonal consistency is a result of being designed with greater proximity effect and off axis rejection making the Ball an ideal choice for drum overheads, backing vocals, and acoustic or electric guitars.

- Integrated fully positional stand mount adapter
- 48V phantom powered

- Sturdy, high-impact plastic
- 146dB SPL
- 35Hz–16kHz frequency response

**AKG****D112**

The AKG D112 is a rugged, dynamic cardioid kick drum microphone that delivers the punch, definition, and low-end impact needed for the most demanding drummers. It handles even the heaviest-hitting drummers, handling up to 160dB SPL with no audible distortion. The D 112 is also an excellent choice for use with bass cabinets, trombones, etc.

- Large-diaphragm dynamic microphone for bass instruments
- Ultra-low distortion
- Built-in windscreen and stand adapter
- Solid and powerful response below 100 Hz
- Narrow band presence rise at 4 kHz
- 168dB SPL
- 20Hz–17kHz frequency response

#AKD112  
**\$219.00**



**SHURE****Beta 56A**

The Beta 56A is a supercardioid dynamic microphone specifically designed for close miking snare drums, tom-toms, percussion instruments, guitar amplifiers, brass instruments, and woodwinds. Its extremely uniform supercardioid pickup pattern provides high gain before feedback and excellent rejection of unwanted noise. A built-in dynamic locking stand adapter with an integral XLR connector simplifies installation.

- Dynamic instrument ideal for drums, amps, brass, and woodwinds
- Uniform supercardioid pattern
- Advanced pneumatic shock-mount system
- Compact design reduces stage clutter
- Neodymium magnet for high signal-to-noise ratio output
- Hardened steel mesh grille resists wear and abuse
- Includes: 5/8"–3/8" (Euro) thread adapter, carrying bag
- Frequency response: 50-16kHz



#SHBETA56A  
**\$159<sup>00</sup>**

**SHURE****Beta 57A**

The Shure Beta57A is an all purpose supercardioid dynamic microphone that delivers great clarity and detail on vocals, acoustic instruments, and both guitar and bass amplifiers. Its high output and musically-tailored frequency response makes the Beta57A an invaluable tool in any engineer's microphone toolbox.

- Ideal for stage or studio
- Neodymium high-output element
- Mic stand adapter and zippered pouch (included)
- Supercardioid pattern ensures high gain before feedback
- 50Hz–16kHz frequency response



#SHBETA57A  
**\$139<sup>00</sup>**

**BLUE**  
**8-Ball**

With its unique and versatile spherical design, the BLUE 8-Ball is a cardioid condenser microphone that features Blue's highly-regarded Class-A circuitry, which is both open and warm. On stage or in the studio, the high-volume capable 8-Ball delivers the full, rich timbre of vocals, percussion, and acoustic instruments.

- Well-suited for vocals, percussion, guitar, and overhead miking

- Adjustable swivel mount adapter for improved versatility
- 48V phantom power
- 150dB SPL
- 35Hz–20kHz frequency response

#BL8BALL  
**\$99<sup>00</sup>**

**SENNHEISER****MD421-II**

The Sennheiser MD421 is a large-diaphragm dynamic microphone known for its warm, robust sound, and durable build. An industry standard among musicians and engineers worldwide, the MD421 is the mic of choice for use on toms, saxophones, and other percussive instruments.

- Handles extremely high sound pressure levels
- Cardioid pattern effectively isolates desired source
- Five-position bass roll-off switch
- 30Hz–17kHz frequency response



#SEMD4212  
**\$379<sup>00</sup>**

**SHURE****Beta 52A**

With its high output Neodymium element, the Shure Beta 52A is an extremely rugged, supercardioid kick drum microphone that delivers the articulated bass response today's contemporary drummer expects.

- Excellent gain before feedback
- Advanced shock system minimizes noise
- Built-in locking adapter and XLR connector for easy setup
- 174dB SPL
- 20Hz–10kHz frequency response



#SHBETA52A  
**\$189<sup>00</sup>**



**AUDIX****D2**

The D2 from Audix is a dynamic hypercardioid microphone that excels at capturing the warmth of percussive instruments. Its body is compact for easy positioning, its capsule designed to withstand loud sound pressure levels for close placement to drums, horns, and woodwinds. Ideal for use in live venues and recording studios both large and small, the D2 will deliver a big punchy sound.

- 48Hz to 18kHz frequency response
- Noise-rejecting true hypercardioid polar pattern
- Lightweight and durable solid aluminum construction
- Ideal for toms, kickdrums, hand drums, brass and woodwinds
- 144dB maximum sound pressure level



#AUD2  
**\$129<sup>00</sup>**

**SHURE****520DX**

The 520DX "Green Bullet" microphone produces a unique sound that has become legendary amongst harmonica players, and its unique shape allows it to fit comfortably in the hands. It features a volume control knob at its base for easy adjustments during a live performance, and an attached cable with a standard 1/4-inch phone plug is perfect for connecting to a high-impedance device.

- Dynamic, omnidirectional harmonica microphone
- High impedance 1/4" output for connection to instrument amplifiers
- 20-ft. two conductor shielded cable with standard 1/4-inch phone plug
- Instantly recognizable green and chrome finished die casting
- 100Hz-5kHz frequency response



#SH520DX  
**\$109<sup>95</sup>**

**AUDIX****i5**

The i-5 is designed with a cardioid polar pattern, allowing it to focus on the particular instrument that is being miked without picking up other instruments or ambient noise on stage. With a smooth and uniform frequency response and the ability to handle sound pressure levels in excess of 140dB, this versatile mic can be used for a wide variety of applications.

- Cardioid, dynamic instrument mic
- Excellent utility mic for both stage and studio
- Precision-cast zinc alloy body and grille for durability
- Handles high SPL's without distortion
- 50Hz-16kHz frequency response

#AUI5  
**\$99<sup>00</sup>**

**SENNHEISER****e609 Silver**

Able to withstand high SPL's without distorting, the e609 Silver's flat-profile capsule facilitates extremely close miking of guitar cabinets and is also exceptional for drum miking and tight placements, like toms. Its supercardioid design improves isolation in live sound reinforcement and recording applications while its increased output and wider frequency response improve performance. Its sound inlet basket, made of refined steel, is distinguished by a unique silver address side.

- Supercardioid, dynamic instrument mic
- Hum-compensating coil reduces electrical interference
- Metal construction for years of hard use
- Includes protective pouch and mic clip
- 40Hz-18kHz frequency response

#SEE609  
**\$109<sup>00</sup>**

**SENNHEISER****e602II**

The e602II is a dynamic microphone especially suitable for use with kick drums, bass guitar cabinets, tubas, and other low-frequency instruments. Its lightweight, high-performance voice coil construction delivers fast transient response and the low frequency extension and mid band attenuation produce an ultra-smooth pre-shaped signal. The microphone is ideal for direct use on the most problematic bass signal sources.

- Cardioid, dynamic bass instrument mic
- Lightweight aluminum body for stable boom-arm positioning
- High-grade voice coil performance
- Excellent isolation from other on stage or studio signals
- Included protective pouch and integral stand mount
- 20Hz-16kHz frequency response

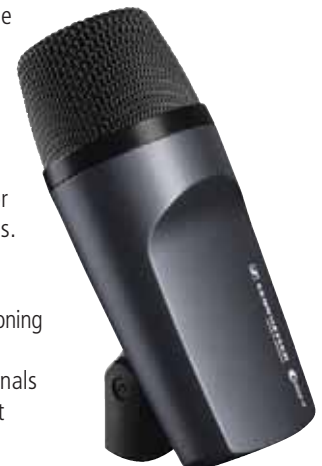

#SEE602II  
**\$159<sup>00</sup>**

**AUDIO TECHNICA****ATM250**

Excellent with high SPL's, the new ATM250 hypercardioid dynamic is tailored for kick drum, percussion, brass, and other highly-dynamic instruments. Its rich, warm low-frequency response gives the microphone excellent presence. The microphone is equipped with a rare earth neodymium magnet and a tight hypercardioid polar pattern. It includes a professional isolation clamp to provide secure mounting, versatile positioning, and effective dampening of unwanted mechanical noise.

- Hypercardioid, dynamic instrument microphone
- Big, warm low-frequency response with excellent presence
- Polar pattern reduces pickup of sounds from the sides and rear
- Handles very high SPL's at close range
- 40Hz-15kHz frequency response



#AUATM250  
**\$179<sup>00</sup>**

**CAD****TSM411**

The TSM411 is a percussion/general purpose microphone that incorporates an all new "duo-point" suspension. This technology provides remarkable shock isolation and ballistic stability, which is very important for successful reproduction of sound sources originating from percussion instruments such as tom toms, snares, cymbals, congas, and guitar and keyboard amps. A rubber-clad soft swivel is also included for mounting the TSM411.



#CATSM411  
**\$69<sup>99</sup>**

- Supercardioid, dynamic general purpose instrument mic
- Compact design is perfect for difficult mic placements
- Tight pickup pattern rejects unwanted neighboring sounds
- Neodymium element offers increased clean output at high SPL's
- 50Hz-15Khz frequency response

**AUDIO TECHNICA****ATM250DE**

The ATM250DE dual-element instrument microphone features cardioid condenser and hypercardioid dynamic capsules combined in a single housing. The innovative use of two polar patterns is ideal for kick drum: the hypercardioid dynamic element focuses tightly on the aggressive attack of the beater, while the condenser captures the round tonalities of the shell. The elements are positioned in a perfect phase relationship, something practically impossible to achieve with two separate microphones.

- Dual cardioid/hypercardioid dynamic elements
- Perfect for kick drum, guitar amps, and instrument use
- Includes single 5-pin to two 3-pin XLR dual shielded cable
- 40Hz-20kHz condenser and 40-15kHz dynamic frequency response

#AUATM250DE  
**\$299<sup>00</sup>**

**CAD****e60**

The e60 is designed specifically for use as an instrument microphone and is great for virtually all acoustic, wind, and amplified instruments. One of this mic's most popular uses is as an overhead for drums, yet it also excels at miking stringed instruments such as acoustic guitars. It also features a four-position roll-off switch for extended "tuning" of the frequency response and a -10dB pad to adjust the output level of the microphone by 10dB accordingly.

- Cardioid, condenser instrument microphone
- 16mm, 24k gold-sputtered condenser capsule
- 4 position hi-pass filter - flat, 40Hz, 80Hz, and 120Hz
- Durable black "leather feel" urethane housing with black grille screen
- 30Hz-20kHz frequency response

#CAE60  
**\$199<sup>00</sup>**

**AUDIO TECHNICA****ATM650**

The ATM650 is a versatile addition to the Artist Series and features a new multi-stage flat grille design for precise positioning close to the sound source. Equipped with a neodymium magnet for high-output performance, it has a frequency response tailored for clear sound reproduction of guitar cabinets, snare, and percussion. Its innovative dual-wall floating construction greatly reduces handling noise.

- Hypercardioid, dynamic instrument microphone
- Neodymium magnet for improved output and transient response
- Excellent isolation of desired sound source
- Rugged, all-metal design and construction for years of trouble-free use
- Includes Quiet-Flex stand clamp and protective pouch
- 80Hz-17kHz frequency response

#AUATM650  
**\$99<sup>00</sup>**



**SHURE****Beta-98H/C**

The Beta98H/C is a high-quality cardioid condenser instrument microphone designed to reproduce the full frequency range of brass, woodwinds, strings, and percussion accurately. Its integrated gooseneck, ratcheting swivel joint, and isolation shock mount allows it to be easily positioned while reducing unwanted instrument noise. The Beta98H/C handles even the highest sound pressure levels with smooth, uncolored results.

- Tailored frequency response for open, natural sound
- Design allows optimal microphone positioning
- Cardioid pattern provides excellent gain-before-feedback and noise rejection
- Compact and lightweight for low visibility
- 143.5dB SPL • 20Hz–20kHz frequency response



#SHBETA98HC  
**\$209<sup>00</sup>**

**SHURE****Beta-98D/S**

The Beta98D/S is a premium supercardioid condenser instrument microphone designed to stand up to the highest sound pressure levels produced by toms, snares, hats, and congas. It's ideal for both live and studio applications and excels in providing an ultra-uniform response with superior gain-before-feedback and noise rejection. The flexible gooseneck allows for any number of mounting configurations, supplying limitless sound options.

- Natural sound with ultra-wide dynamic range
- Interchangeable microphone cartridges with different polar patterns
- Excels in studio recording applications
- Supercardioid pattern provides superior rejection of off-axis sound
- 160dB SPL • 20Hz–20kHz frequency response



#SHBETA98DS  
**\$229<sup>00</sup>**

**AUDIO-TECHNICA****ATM350**

The ATM350 is a condenser instrument microphone designed for clip-on, close-miking situations involving brass, kit drums, percussion, saxophones, and even piano. The cardioid pick-up pattern minimizes off-axis noise and ambience, and the unusually high SPL capacity of the microphone ensures clean, distortion-free, full-range sound reproduction. Audio-Technica makes some of the best-sounding, durable, and value-laden mics on the market.

- Clip-on condenser microphone for brass, percussion, piano and saxophone
- Cardioid pick-up pattern with good off-axis rejection
- 145dB SPL • XLR connector, battery or 48V power
- 30Hz-20kHz frequency range



#AUATM350  
**\$249<sup>00</sup>**

**AUDIX****ADX 20i**

The ADX 20i is a multi-purpose cardioid condenser microphone designed to handle a variety of clip-on applications. Especially effective on brass, the ADX 20i benefits from a wide frequency response and low-noise electronic circuitry, delivering a tone that is smooth and warm, not typical of microphones this size. Its high-tension spring clamp and multi-position gooseneck optimize the placement of the mic element.

- Ideal multi-application cardioid condenser instrument microphone
- Durable machined brass housing • Element capsule is designed for easy replacement
- Foam windscreen included • 130dB SPL • 40Hz–20kHz frequency response

#AUADX20I  
**\$149<sup>00</sup>**

**AUDIX****Micro-D**

The Micro-D is a very easy-to-use, low profile miniature condenser microphone. Its modular design allows for the use of three different clips and two different capsules, providing a smooth, uniform response for a variety of applications including drums, percussion, instrument cabinets, vocals, and acoustic instruments. The stock Micro-D has a hypercardioid pattern and can handle sound pressure levels up to 140dB.

- Very compact and versatile miniature condenser microphone
- Modular system can use 3 different clips or 2 different capsules
- Housed in an aluminum ring with a rubber shock-mount system
- Includes phantom power adapter, D-vice gooseneck clip, and stand thread adapter
- 140dB SPL • 40Hz–20kHz frequency response



#AUMICROD  
**\$189<sup>00</sup>**



**AUDIX****F-90**

The F-90 is a compact gooseneck condenser microphone designed for use with drums, percussion, and instruments in live sound and live broadcast applications. Its durable, built-in steel clamping system makes it simple to attach to the rims of drums, percussion instruments, and a variety of other instruments such as sax, trumpet, and trombone.

- Miniature instrument condenser microphone
- Cardioid pick-up pattern
- Flexible gooseneck fits into very tight places
- Frequency Response: 50Hz–18kHz
- 135 dB SPL
- Includes: phantom power adapter, integral clamp, cable, windscreen, and carrying pouch
- Machined aluminum housing

#AUF90  
**\$99<sup>00</sup>****AMT**  
**S15G**

The S15G is a condenser microphone system specifically designed for acoustic guitar. The pick-up pattern on the microphone is designed to achieve higher gain before feedback, while the element captures the best sound quality possible. The mic can be positioned to accommodate the player, and it includes a belt-pack that powers the microphone. The S15G is an essential tool for musicians that require a natural sound on stage.

- Powers with 9V battery or phantom power
- Includes a hard shell protective case
- Can be integrated into a wireless system
- 50Hz–18kHz frequency response
- 140dB SPL
- Microphone weighs only 44 grams

#AMS15G  
**\$562<sup>40</sup>****AMT**  
**System 1**

The System 1 is a professional miniature cardioid condenser clip-on microphone, designed for use with high-SPL brass, saxophone, and percussion instruments. Shock-mounted onto an isolation ring, the microphone pick-up pattern exhibits excellent off-axis rejection, and is secured to a universal clamp with an adjustable gooseneck. The System 1 is attached to a belt-pack preamp which provides phantom power.

- Miniature condenser instrument microphone
- Cardioid pick-up pattern
- 50Hz–18kHz frequency response
- 120dB SPL
- 9V battery or phantom power
- Universal clamp, flexible isolation ring for mount

#AMS1  
**\$343<sup>00</sup>****SENNHEISER****E 608**

The E 608 is a high performance supercardioid clip-on instrument microphone designed to provide clean, high-output audio from woodwinds, brass, and drums. It features metal construction and a reinforced glass-fiber casing with extensive damping and shock mounting, protecting the mic element from physical damage and excessive noise and vibration. The neodymium magnetic structure delivers high output and low-noise audio regardless of climatic conditions.

- Supercardioid instrument microphone with hum-compensating coil
- Rugged, reliable build includes metal and high-strength, glass-fiber construction
- Natural tone ideal for high output woodwind, brass, and percussion recordings
- Clamp and gooseneck mounting simplifies capsule placement • 40Hz–16kHz frequency response

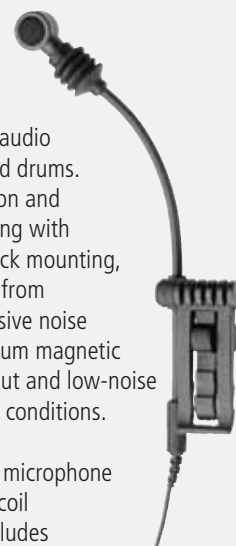
#SEE608  
**\$179<sup>00</sup>****SENNHEISER****E 604**

The rugged E 604 dynamic instrument microphone is designed to reproduce the full frequency ranges of drums, brass, and percussion faithfully with little distortion or noise. Its cardioid pattern and neodymium element reduces off-axis noise while capably handling even the loudest SPL's. Easily mount the E 604 to a mic stand or drum rim with the integral stand mount or clip.

- Dynamic cardioid instrument microphone
- Durable construction makes it ideal for live sound applications
- Integral stand mount and clip
- Designed to mount easily on drum rims or microphone stands
- Greater than 150dB SPL
- 40Hz–18kHz frequency response

#SEE604  
**\$139<sup>00</sup>**

## AUDIX DP-ELITE 8

The DP-Elite 8 drum mic kit is identical to the Audix DP-5A system with the important addition of three SCX1 pencil-style true condenser microphones. With two placed as overheads and the other as a high-hat microphone, the SCX1 is extremely quiet, and its flat response brings a sense of depth to the overall sound of the kit.



#AUDPELITE8  
**\$1999<sup>00</sup>**

- (1) i-5 snare mic • (2) D-2 tom mics
- (1) D-4 floor tom mic • (1) D-6 kick mic
- (2) SCX1-c overhead
- (1) SCX1-hc hi-hat mic
- (4) D-Vice gooseneck clips
- Includes aluminum road case

## AMT A95-4C

This kit contains four handmade AMT A95 drum/percussion microphones in their own foam-lined hard shell carrying case. These are the smallest self-contained drum microphones on the market and offer the most transparent reproduction of sound possible. Their shock-mounted clamp attaches to virtually any drum rim and their rugged construction can withstand the high impact of drum sticks.



#AMA954C  
**\$769<sup>95</sup>**

- Cardioid condenser (4) mic kit
- 30Hz to 20kHz frequency response
- (4) inline preamps with XLR connections
- Anodized aviation aluminum housing
- Drums, toms, snare, and hand percussion
- Includes molded protective case

## EARTHWORKS DK25/L

The Earthworks DK25/L drum mic kit is designed for both live and studio applications and utilizes only two mics for overheads and one for kick drum, with exceptional results. The kit includes three SR25 microphones which feature an extended high-frequency response of 25kHz and can handle up to 145dB SPL. Also included is the KickPad inline pad/EQ processor that gives you an incredible "instant kick drum sound."



#EADK25L  
**\$1839<sup>00</sup>**

- (3) SR25 cardioid condenser microphones
- 50Hz to 25kHz frequency response
- Includes padded aluminum carrying case
- Perfect for live applications • KickPad inline pad/EQ and windscreen

**DK25/R** recording kit with (2) TC25 omnidirectional overheads #EADK25R..... **\$1,839.00**

## AUDIX DP-5A

The DP-5A drum package gives you everything you need for a great-sounding and dependable microphone package. These mics have been designed, assembled, and tested by Audix in the USA and feature protective steel grilles with precision-cast zinc alloy bodies. With their short profile and transparent sound quality, the microphones in this package are easy to maneuver into the perfect spot.



#AUDP5A  
**\$659<sup>00</sup>**

- (1) i-5 snare mic • (2) D-2 tom mics
- (1) D-4 floor tom mic • (1) D-6 kick mic
- (4) D-Vice gooseneck clips
- Includes aluminum road case

## AUDIX FUSION-7

The Fusion 7 represents a great value in an affordable drum microphone package. In addition to the F14 kick drum microphone, this pack features three F10 dynamics for snare and rack toms, one F12 for floor tom, and two F15 condenser mics which are ideally suited for over heads, high hat, and toms. All mics are designed with an integral clip in order to simplify setup and storage.



#AUF7  
**\$399<sup>00</sup>**

- Very affordable drum microphone kit
- Solid Audix build quality
- Compact profile for easy placement
- Perfect for studio or live use
- Packaged in an aluminum carrying case

**SHURE**  
**PGDMK4/XLR**

The PGDMK4 microphone kit is a great alternative if you are trying to gain a more definitive drum sound for your live performances or studio recordings. Shure PG series mics feature many of the same durability and performance attributes of other sure microphones at an attractive price.

- (1) PG52 cardioid dynamic kick drum mic
- (3) PG56 cardioid dynamic snare/tom mics
- (3) A50D flexible yet sturdy drum mounts
- (3) 15 foot XLR cables
- Includes foam-lined carrying case



#SHPGDMK4XLR  
**\$249<sup>00</sup>**

**PGDMK6** adds (2) PG81 overhead mic #SHPGDMK6XLR.....**\$399.00**

**SAMSON**  
**SADK8**

The SADK8 8 piece gives you all of the tools you need to mic a drum kit confidently in a live or studio setting. These cardioid microphones are voiced specifically for each drum, and gold-plated XLR connections insure a low noise path.

- (2) C01 large diaphragm condensers for overheads
- (3) Q-toms with integrated rim mount clip
- (1) Q-snare with rim mount clip
- (1) Q-kick bass drum mic
- (1) C02H mini pencil hi-hat condenser
- Includes rugged road case



#SA8DMK  
**\$299<sup>00</sup>**

**SADK7** (7) piece drum mic set #SA7DMK.....**\$249.00**

**SADK5** (5) piece drum mic set #SA5DMK.....**\$149.00**

**CAD**  
**DMTP-4**



The DMTP4 is one of the most cost effective ways to start dialing in your own drum sound with specialized mountable microphones. The models in this kit are available only in DMTP packs and have been dialed in at the factory for optimum response.

- (2) TM211 cardioid dynamic tom mics
- (1) SN210 supercardioid dynamic snare mic
- (1) KM212 cardioid dynamic kick drum mic
- Compact size for easy placement
- Comes in protective travel case

#CADMTP4  
**\$99<sup>99</sup>**

**SENNHEISER**  
**e604 Microphone Kit**



#SEE6043K  
**\$339<sup>95</sup>**

The tough reinforced glass-fiber body of the e604 is built to take the shocks of being placed directly on a drum rim while simultaneously suppressing impact noise. It can handle SPL's in excess of 160dB and yet deliver clear, low-distortion results. The kit comes with three microphones and is a great way to capture drums, both live and in the studio.

- Pack of (3) dynamic cardioid mics
- 40Hz to 18kHz frequency response
- Shock-mounted capsule and compact design
- Hum-compensating coil reduces interference
- Includes (3) protective pouches

**SHURE**  
**DMK57-52**



#SHDMK5752  
**\$392<sup>95</sup>**

The industry standard for snare drum and a reliable choice for toms, The SM57 features a contoured frequency response that cuts through the mix with exceptional impact, while reproducing sound accurately. The supercardioid Beta 52A is perfect for kick drum and derives its low-end punch from a carefully tailored frequency response.

- (3) SM57 dynamic cardioid microphones
- (1) Beta 52A kick drum microphone
- (3) A56D microphone drum mounts
- Drum mounts reduce clutter and ease setup
- Includes a lightweight, durable carrying case



**AUDIO-TECHNICA**

**AT808G**

With its frequency response custom-tailored for voice, the AT808G is a subcardioid dynamic microphone well suited for use in environments where excessive room noise compromises speech intelligibility. Great for industrial applications, restaurants, studio talkback, and lectern presentations, the AT808G's rugged design provides reliable performance for even the most demanding applications.

- Dynamic 16" subcardioid gooseneck microphone
- High quality talk-back microphone
- Plugs directly into XLR mounting surfaces
- Internal windscreen reduces breath and wind noise
- Subcardioid pickup pattern reduces speech plosives
- 200Hz–5kHz frequency response

#AUAT808G  
**\$122.95**



**AUDIO-TECHNICA**

**U857QU**

The U857QU is a 19" quick-mount gooseneck condenser microphone featuring AT's "UniLine" line-cardioid element (with a tightly-focused 90° acceptance angle). Equipped with "UniGuard" innovations that offer unsurpassed immunity from radio frequency interference, the U857QU accepts interchangeable elements available in cardioid, hypercardioid, and omni polar patterns.

- Quick-mount condenser microphone with "shotgun-style" element
- Superior off-axis rejection
- Ultra-flexible, robust design resists inadvertent repositioning
- 80Hz low-cut filter reduces low-end rumble
- 30Hz–20kHz frequency response

**U857QL** 19" cardioid version  
#AUU857QL.....**\$199.95**

#AUU857QU  
**\$219.95**



**AUDIO-TECHNICA**

**Pro Series PRO47TL**

The PRO47 is a cardioid condenser 15.8" gooseneck microphone designed for use in boardrooms, schools, houses of worship, and more. It mounts easily to any 5/8"-27 stand or the included threaded mounting stud, and features a low-mass diaphragm for superior performance. Self-contained electronics eliminate the need for external power.

- Flat, smooth frequency response
- Quiet, fixed-placement gooseneck
- Permanently-attached cable
- 70Hz–16kHz frequency response

**PRO47T** 12.4" version #AUPRO47T.....**\$129.95**  
**PRO49Q** 13" quick-mount cable-less version #AUPRO49Q.....**\$107.95**  
**PRO49QL** 16.5" quick-mount cable-less version #AUPRO49QL...**\$107.95**  
**AT8416** shock mount for "adapter and quick-mount" goosenecks #AUAT8416.....**\$49.95**

#AUPRO47TL  
**\$129.95**



**COUNTRYMAN**

**Isomax 4RF**

The Isomax 4RF is an ultra-low noise gooseneck microphone with an Active Vibration Isolation system design, available in either cardioid or hypercardioid versions for podium or boardroom use. It features advanced RF technology which eliminates interference from cell phones, computers and faulty electrical sources. The flexible or rigid goosenecks are manufactured in 12", 18", and 24" versions equipped with an XLR connector on the microphone base, and offer a linear 70Hz-18kHz frequency response.

**M4HPRF** hypercardioid version with flexible or rigid 12", 18" and 24" gooseneck #COM4HP5RF\*.....**\$317.50**  
**M4CPRF** cardioid version with flexible or rigid 12", 18" and 24" gooseneck #COM4CP5RF\*.....**\$317.50**



**CROWN**

**LM-300A**

The LM-300A is a 17" supercardioid condenser gooseneck microphone designed to provide a smooth, wide-frequency response for natural reproduction of singing or speaking voices. Its silent adjusting gooseneck effectively reduces mechanical noise and low-end room rumble, while the supercardioid pattern rejects more background noise, room reverberation, and feedback.

- Designed for high-quality speech reproduction
- Two-stage pop-filter reduces breath noise
- Built-in low-cut filter reduces handling noise
- 12-48V phantom power
- 80Hz–15kHz frequency response

#CRLM300A  
**\$316.50**



**ELECTRO-VOICE**

**PolarChoice Satellite**

The PC-Sat-5 is an extremely versatile free-standing 5" gooseneck microphone. Its elegant, low-profile base is capable of housing a Telex of Electro-Voice bodypack wireless transmitter. This, along with multi-pattern versatility, makes the easy-to-use Satellite ideal for flexible microphone placement and maintaining a clean appearance in virtually any installation.

- Consistently smooth voicing across all four patterns
- Free-standing weighted base for reliable stability
- Programmable mute switch
- Bodypack transmitter creates a high-quality wireless microphone
- 50Hz–20kHz frequency response

**PCS12** 12" version #ELPCS12.....**\$429.00**  
**PCS18** 18" version #ELPCS18.....**\$429.00**



**ELECTRO-VOICE**

**RE90P12**

The RE90P12 is a slim-profile podium microphone acoustically designed for high-quality sound reinforcement and public address applications. This 12" gooseneck picks up and reproduces sound naturally from a direct or distant source and can be easily positioned without excessive twisting and turning.

- Small, streamlined appearance
- Uniform cardioid pattern
- Mounts quickly to any lectern, pulpit or podium
- Steel construction reduces noise from RFI
- 70Hz–15kHz frequency response

**RE90P18** 18" version #ELRE90P18.....**\$186.00**  
**CPSM** permanent install shock mount kit #ELCPSM.....**\$22.50**



**SENNHEISER**

**Gooseneck Combo Kits**

Sennheiser offers three microphone capsules and gooseneck options for a variety of applications. The ME34 cardioid, ME35 supercardioid, and unique ME36 directional mini-shotgun elements perform smoothly across all frequencies with the latter two providing superior isolation and detail. All contact points are gold-plated and corrosion-resistant, insuring long-term reliability.

- Cardioid, Supercardioid, and mini-Shotgun elements
- 6", 16", and a special 16" gooseneck with additional top bend
- Cardioid version flexible for most miking applications
- Supercardioid rejects feedback and delivers high isolation
- Mini-shotgun provides detailed direction, high SPL, and lower self-noise

**I15C** 6" cardioid version 40Hz–20kHz frequency response #SEI15C.....**\$266.50**  
**I40C** 16" cardioid version 40Hz–20kHz frequency response #SEI40C.....**\$279.95**  
**I15L** 6" mini-shotgun version 40Hz–20kHz frequency response #SEI15L.....**\$334.95**  
**I42S** 16" top-bend gooseneck supercardioid 50Hz–20kHz freq. response #SEI42S.. **\$296.95**



**SHURE**

**Easyflex EZG & EZG-SE series**

Shure "Easyflex" EZG and EZG-SE Series microphones are miniature gooseneck-mounted electret condenser microphones designed primarily for speech and vocal pickup. Ideal for boardrooms, conference centers, classrooms, and houses of worship, these inexpensive cardioid microphones and are available in four different models.

- Cardioid polar pattern
- Included integrated preamp and foam wind screen
- 50Hz–17kHz frequency response

**EZG/12** 12" gooseneck, locking flange mount #SHEZG12.....**\$118.95**  
**EZG/12SE** 12" gooseneck, side exit #SHEZG12SE.....**\$129.95**  
**EZG/18** 18" gooseneck, locking flange mount #SHEZG18.....**\$118.95**  
**EZG/18SE** 18" gooseneck, side exit #SHEZG18SE.....**\$129.95**



**SHURE**

**Microflex MX412DC**

The MX412 is a 12" gooseneck microphone that is not only fully adjustable, but allows for the interchangeable Microflex condenser microphone element. Available in cardioid, supercardioid, and omnidirectional polar patterns, the interchangeable cartridges deliver a wide frequency response and accurate sound reproduction for a variety of applications.

- Perfect for houses of worship, boardrooms, courtrooms, and conference centers
- Balanced low-noise transformerless output
- Shock mount provides 20dB of isolation from vibration
- Programmable on/off switch with LED indicator
- 50Hz–17kHz frequency response

**MX412DC** 12" desktop cardioid version #SHMX412DC.....**\$243.95**  
**MX412DS** 12" desktop supercardioid version #SHMX412DS.....**\$249.95**  
**MX418C** 18" cardioid version #SHMX418C.....**\$186.50**  
**MX418S** 18" supercardioid version #SHMX418S.. **\$192.50**

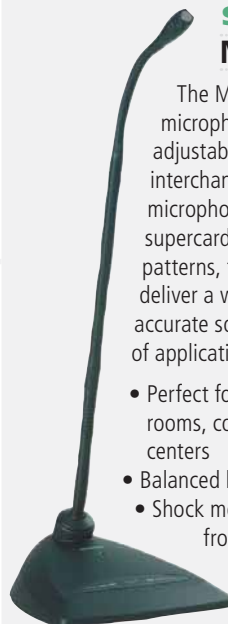

**AUDIO-TECHNICA**

**AT849**

The AT849 is a stereo cardioid condenser boundary microphone featuring two closely-matched elements configured in an X/Y stereo polar pattern. Designed for professional surface-mount applications, it provides the spatial impact and realism of a live sound field for broadcast, recording, and sound reinforcement.



#AUAT849  
**\$348<sup>95</sup>**

- X/Y stereo cardioid condenser
- Minimally visible, low-profile design
- Rugged, die-cast case and non-slip rubber bottom reduces low-end noise
- Switchable low-frequency roll-off
- Each channel requires 9-52V phantom power
- 30Hz–20kHz frequency response

**CROWN**  
**PCC-160**



The Crown PCC-160 is the industry-standard boundary microphone featuring a half-supercardioid electret condenser element whose Phase Coherent Cardioid design and surface mounting provides superior

#CRPCC160  
**\$289<sup>95</sup>**

gain before feedback and sensitivity for a wide, smooth frequency response. The inconspicuous but rugged PCC-160 covers a relatively large boundary surface while reducing the unwanted noise associated with both lectern and stage mounted presentations.

- Small mic capsule ensures phase coherency and clarity
- Rugged, heavy-gauge all steel body withstands rigors of stage use
- Three position "bass-tilt" switch offers flat/boost/cut low-frequency tailoring
- 12-48V phantom power
- 50Hz–18kHz frequency response

**PCC-130** smaller, elegantly designed half-cardioid version (50Hz–20kHz) #CRPCC130.....**\$256.95**

**AKG**

**C 542 BL**

The extremely small C 542 BL is a high-quality omnidirectional boundary microphone that combines high sensitivity and low self-noise with superior sound and rugged design build. Sonically versatile, the C 542 BL delivers a smooth, uniform response that's ideal for recording room environments with instruments.

- Extremely thin, inconspicuous omnidirectional boundary mic
- Very sensitive condenser element with high headroom
- Lightweight, easy-to-place permanently or temporarily
- 9-52V phantom power
- 20Hz–20kHz frequency response



#AKC542BL  
**\$279<sup>00</sup>**

**AUDIO-TECHNICA**

**Pro 44**

The PRO 44 is a half-cardioid unidirectional boundary microphone equipped with a wide-range condenser element for superior performance.

This versatile low-profile microphone's self-contained electronics eliminate the need for external power modules, and is ideal for conference tables, podiums, lecterns, and many other installed-sound uses.



#AUPRO44  
**\$104<sup>50</sup>**

- Low-profile for minimal visibility
- Self-contained electronics eliminates the need for external electronics
- Rugged design and build
- 70Hz–16kHz frequency response

**PRO42** least visible miniature condenser version (70Hz–14kHz)  
#AUPRO42.....**\$96.95**

**AUDIO-TECHNICA**

**U851A**

Designed for surface-mount applications that require high-quality sound reinforcement, the half-cardioid U851A microphone is ideal for professional recording, television, video conferencing, and other critical sound pickup situations. It performs in the most challenging environments and relies on its heavy die-cast case with silicon foam bottom pads to minimize surface vibration and protect its high-quality interchangeable condenser element.

- Low-profile design available in cardioid, hyper, and omni polar patterns
- PivotPoint rotating output connector allows rear or bottom exiting
- UniSteep low-cut filter and UniGuard RFI shielding standard
- Battery of phantom powered
- 30Hz–20kHz frequency response

**U851R** phantom-powered only version  
#AUU851R.....**\$192.50**

**U851RW** phantom-powered only (white)  
#AUU851RW.....**\$192.50**



#AUU851A  
**\$219<sup>95</sup>**



**SAMSON**

**CM11B**

The CM11B is a low profile, surface-mount boundary microphone ideal for conference room tables, alters, or hanging on walls. It features an omnidirectional condenser element with a wide frequency response and internal electronics requiring no external power supply. Its metal, mesh grille top and rubber bottom protect and isolate the CM11B from damage and low-end vibration.



#SACM11B  
**\$99.00**

- Omnidirectional condenser
- Low-profile with onboard electronics and no external power supply
- Mini XLR connector
- Standard 9-52V phantom power
- 30Hz–18kHz frequency response

**CM10B** half-cardioid version (30Hz–18kHz) #SACM10B ..... **\$99.00**

**CM11BW** omnidirectional version (white) #SACM11BW ..... **\$99.00**

**CROWN**

**PZM-185**



#CRPZM185  
**\$189.95**

The PZM-185 (Pressure Zone Microphone) is a hemispherical (half-omni) electret condenser microphone ideal for interviews, broadcast, video production, and lectures. Its low-profile design reduces "mic fright" and clutter, and allows it to be unobtrusively placed on large surfaces such as tables, walls, lecterns, or the floor.

- Ideal for table-top and on-floor placement
- Internal AA battery for phantom power
- Removable boundary "paddle"
- High-impact plastic housing and steel power module

**SG2** inexpensive half-omni condenser mic with 1/8" phone plug #CRSG2..... **\$69.95**

**SHURE**

**EASYFLEX EZB/C**



The Shure EZB microphones are small, surface-mounted electret condenser microphones designed for conference tables, stage floors, and lecterns. Their wide frequency range makes them especially suitable for speech and vocals in sound reinforcement and recording applications. They feature a flat, uncolored sound, sleek, low-profile design, and in-line preamp, allowing a reduction in overall chassis size.

#SHEZBC  
**\$112.95**

- Cardioid condenser boundary microphone
- Flat response with uncolored sound
- In-line preamp reduces visible size of the microphone
- 50Hz–17kHz frequency response

**EZBO** omnidirectional version #SHEZBO..... **\$99.95**

**SANKEN**

**CUB-01**

(shown in grey)



#SACUB01GY  
**\$449.00**

The CUB-01 is a professional boundary microphone that utilizes its unique square-shaped cardioid capsule to enlarge the effective area of the diaphragm significantly, resulting in a sound that is rich and natural. "Full-bodied" narration and dialogue are now reproduced without the unnecessary background noise. This revolutionary design eliminates the need to overdesign the acoustic construction to create cardioid directivity in TV, film, and broadcast applications.

- Ideal for TV and film field shooting, broadcast studios, and conference tables
- Uniquely-designed square cardioid condenser capsule
- Special design overcomes limitations of similar boundary mics
- Incredibly small and light, easy to conceal and attach
- 70Hz–20kHz frequency response

**CUB01BE** beige version #SACUB01BE ..... **\$449.00**

**SHURE**

**MX393/O**

The MX393/O is an omnidirectional boundary condenser microphone, designed for use in boardroom, sound reinforcement, focus-group, and interview applications. The polar pattern allows for 360° pickup with consistent level and frequency response, perfect for large-table conferencing and meetings. The condenser element offers excellent speech clarity, and the microphone is equipped with useful programmable switches for Push-to-Talk, Push-to-Mute, and Push-On/Push-Off functionality.



#SHMX393O  
**\$194.95**

- Compact condenser boundary microphone
- Omnidirectional pick-up pattern
- 50Hz-17kHz frequency response
- 111.5dB SPL
- XLR connector
- 11-52V phantom power
- Programmable switching with LED indicator

**Cardioid Version** #SHMX393C..... **\$207.95**

**Supercardioid Version** #SHMX393S ..... **\$213.95**

**AUDIO-TECHNICA****U853 Series**

The U853 Series is comprised of high-quality cardioid condenser hanging microphones known for their clear, transparent sound and extremely wide frequency response. Ideally suited for stage sound reinforcement, they allow every musical detail to be heard with low distortion and superior RFI rejection. The microphones accept interchangeable elements available in cardioid, hypercardioid, omnidirectional, and the ultra-responsive UniLine line-cardioid polar patterns.

- Cardioid condenser hanging microphone
- Interchangeable elements to permit angle of acceptance from 90° to 360°
- 80Hz UniSteep filter
- Microphones include: windscreen, steel hanger, power module, and stand adapters
- 30Hz–20kHz frequency response

<b>U853R</b> cardioid version with phantom power only #AUU853R .....	<b>\$184.95</b>
<b>U853RU</b> UniLine line-cardioid version with phantom only #AUU853RU .....	<b>\$202.95</b>
<b>U853RW</b> cardioid version with phantom power only (white) #AUU853RW .....	<b>\$184.50</b>
<b>U853A</b> cardioid version battery or phantom-powered #AUU853A .....	<b>\$218.50</b>
<b>U853AW</b> cardioid version battery or phantom-powered #AUU853AW .....	<b>\$218.50</b>

**CROWN****CM31**

The CM31 is a high-quality miniature supercardioid condenser microphone with a smooth, wide-range frequency response that's both clear and open. Ideally suited for hanging above choirs or live studio audiences, the versatile CM31 reliably delivers quality results for recording or broadcast applications.

- Supercardioid electret condenser microphone with built-in electronics
- Ideal for choirs, orchestras, stage production, and more
- 30' permanently-attached cable with XLR connector
- Focused pattern reduces feedback and low frequency roll-off switch reduces rumble
- 12-48V phantom power
- 40Hz–20kHz frequency response

<b>CM31W</b> white version #CRCM31W .....	<b>\$232.50</b>
<b>CM30</b> version w/electronics mountable to standard electrical outlet box #CRCM30 .....	<b>\$218.95</b>
<b>CM30W</b> version w/electronics mountable to standard electrical outlet box (white) #CRCM30W .....	<b>\$214.95</b>

**AUDIO-TECHNICA****Pro 45**

The inexpensive Pro 45 is a wide-range miniature condenser microphone that features a cardioid pickup pattern and unobtrusive design. This versatile microphone is ideal for capturing the voices of people on a church or theatre stage, and for the reproduction of orchestral and choral music. The Pro 45's low-profile look and robust vinyl-coated steel hanger allow it to be positioned inconspicuously over a stage without distracting the audience.

- Wide-range condenser element with low-mass diaphragm for superior performance
- Self-contained electronics eliminate need for external power modules
- Permanently attached 25' cable with XLR male connector
- Includes the AT8146 foam windscreen and unobtrusive steel hanger
  - 134dB SPL (ideal for suspension over choirs)
  - 70Hz–16kHz frequency response

<b>Pro 45W</b> white version #AUPRO45W .....	<b>\$104.50</b>
---	-----------------

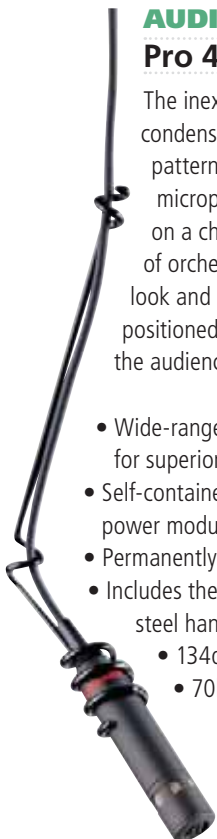
**ELECTRO-VOICE****RE90H**

The RE90H is a very compact back-electret condenser hanging microphone with an extended, flat frequency response and well-controlled cardioid polar pattern. It's specifically designed for live pickup of choirs, instrument, vocal groups, and theater. Exceptional high sensitivity and pattern control make the RE90 ideal for distant sound pickup without feedback or distortion.

- Compact, cardioid condenser hanging microphone
- Shielded pre-amp minimizes electrical noise and RFI
- Highly sensitive, smooth frequency response, ideal for distant miking
  - 25' braided, shielded cable maintains mic position (not rotation)
  - Non-reflective casings
    - XLR connector
    - 9-52V phantom power
    - 75Hz–15kHz frequency response

<b>RE92H</b> premium wide-response cardioid version w/hi-pass filter (40Hz–20kHz) #ELRE92H .....	<b>\$249.00</b>
--	-----------------



## AUDIX ADX-40HC

The ADX-40HC is a miniature hypercardioid condenser designed to hang from an overhead position for professional live sound, music, theater, and broadcast applications. It features a focused pickup pattern that provides maximum rejection of unwanted noise and feedback. The interchangeable capsules are sonically warm and rich, not typical of microphones of this size. They are machined from solid brass and deliver a smooth, uniform response throughout their frequency range. Available in non-reflective black or white.

- Most commonly used for theatrical groups, vocal choirs, and ambient room miking
- Miniature hypercardioid condenser hanging microphone
- Easily interchangeable capsules
- 5-52V phantom powered
- MC40 wire hanger, WS20 external windscreen and 30' cable included
- 40Hz–20kHz frequency response

**ADX40** cardioid condenser version #AUADX40 .....\$209.00

**ADX40W** cardioid condenser version (white) #AUADX40W.....\$219.00

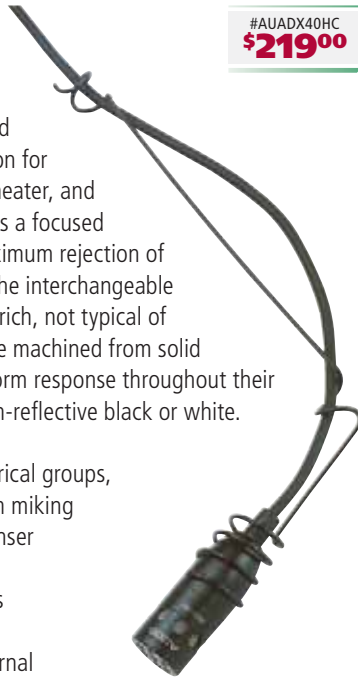

## SHURE Microflex MX202

The Shure MX202 is a miniature electret condenser microphone designed for overhead recording or choirs and performance groups. It's attached to a free-hanging 4" adjustable gooseneck, features interchangeable cartridges and in-line or plate-mounted pre-amps for wide-range, accurate sound reproduction.

- 4" flexible gooseneck attached to 30' mic cable
- Interchangeable Cardioid, Supercardioid, and Omnidirectional cartridge choices
- 11-52V phantom power
- Easy installation and setup
- 50Hz–17kHz frequency response

**MX202BPC** black cardioid version w/plate-mounted pre-amp #SHMX202BPC... **\$167.50**

**MX202BC** black cardioid version w/in-line pre-amp #SHMX202BC.....**\$167.50**

**MX202BS** black supercardioid version w/in-line pre-amp #SHMX202BS.....**\$173.50**



## SAMSON CM12C

The CM12C is an economical miniature hanging condenser microphone designed to be placed over a sound stage with little or no detection. Utilizing the supplied steel hanger, users can easily configure its cardioid element to point toward the sound source, thereby providing a smoother, natural sound and maximum gain-before-feedback. The CM12C's multi-stage windscreen reduces wind noise and artifacts.

- Miniature cardioid hanging mic with sturdy, adjustable steel hanging bracket
- Protected by metal housing with low reflectance, matte black finish
- Included multi-stage windscreen and 30-ft. cable with mini XLR connector
- 9-52V phantom power
- 50Hz–18kHz frequency response



#SHEZOG  
**\$112.95**

## SHURE Easyflex EZO

### Overhead Microphones

The Shure Easyflex Overhead Microphone is a cost-effective condenser microphone for choirs, conferences, performances, and more. It features a wide frequency response and cardioid polar pattern, enabling accurate signal reproduction at both close and distant proximities. A flexible wire mount is included for easy positioning of the microphone.

- Cardioid pattern with wide dynamic range
- High gain-before-feedback
- Includes: adjustable wire mount, in-line pre-amp, 30' cable and windscreen
- 50Hz–17kHz frequency response

**EZO** white color version #SHEZOW..... **\$112.95**





**AUDIO-TECHNICA**

**AT892**

**MicroSet**

The AT892 is a high-quality omnidirectional microphone with an ergonomic under-ear design that's both flexible, lightweight, and features a contoured loop that hooks comfortably behind the ear with or without glasses. Even with its inconspicuous design, vocal reproduction is natural and extremely intelligible, ideal for stage, television, lectures, and houses of worship.

- Omnidirectional condenser headset with secure, comfortable under-ear design
- Wide frequency response with maximum clarity and natural vocal reproduction
- Windscreens, clothing clip, moisture guard and carrying case provided
- 20Hz–20kHz frequency response

- AT892CWTH** beige locking 4-pin version for AT UniPak body-pack wireless #AUAT892CWTH.....**\$299.00**
- AT892CT4TH** beige w/TA4F connector for Shure wireless systems #AUAT892CT4TH.....**\$299.00**
- AT892CT5** black w/TA5F connector for ATW-U101 and Lectrosonics systems #AUAT892CT5.....**\$299.00**
- AT892CTH** beige unterminated version #AUAT892CTH.....**\$289.00**
- AT892CLM3T** beige locking 3.5mm for Sennheiser wireless systems #AUAT892CLM3T.....**\$299.00**



**ELECTRO-VOICE**

**RE97Tx**

#ELRE97TXBE  
**\$299<sup>00</sup>**

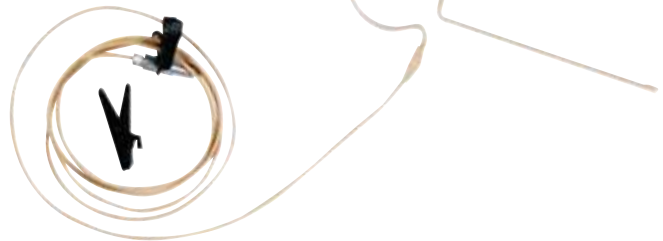

The RE97Tx is an ultra-low profile, omnidirectional condenser headworn microphone designed for use with standard EV and Telex belt-packs. It's intended for houses of worship, theater, corporate AV, and other applications requiring a clean and balanced sound regardless of the microphone position to the source. The RE97Tx design is extremely flexible and easily forms over the ear of the user with the boom shaped to match almost any contour.

- Lightweight, durable, and extremely flexible for precise positioning
- Omnidirectional pattern provides accurate, uniform response
- Moisture resistant, interchangeable for left or right ear
- 50Hz–15kHz frequency response

- RE97TXB** black version of above #ELRE97TXB.....**\$299.00**
- RE97SBE** beige version wired for Shure TA4 bodypacks #ELRE97SBE.....**\$299.00**
- RE97SB** black version wired for Shure TA4 bodypacks #ELRE97SB.....**\$299.00**



**DPA**

**4088**

#DPMMB4088F  
**\$523<sup>50</sup>**

The 4088 is recognized as one of the finest miniature cardioid condenser headband microphones available. Reliable in even the most demanding acoustic environments for open, natural vocals spontaneously, and not the microphone itself—this highly-sensitive, focused design characteristic allows the 4088 to reduce background noise and feedback to an untroubling memory.

- Combines outstanding sound quality, versatility, and visual elegance
- High volume, low distortion ideal for theater and television performance
- Reliable against feedback, acoustic abnormalities, and moisture
- MicroDot connector allows use with virtually any professional wireless system
- 100Hz–20kHz frequency response

- 4088B** black version of above #DPMMB4088B.....**\$523.50**



**COUNTRYMAN**

**Isomax EarSet E6**

The EarSet Isomax E6 is by far the smallest, lightest, and least visible headworn microphone available. It clips directly to your ear, is resistant to moisture and make-up, needs no adjustment for the width of your head, and attaches quickly for easy serviceability. Available in multiple pattern configurations, the virtually invisible E6 is the perfect solution for stage, house of worship and presentation.



- Multiple available patterns effective in tough feedback environments
- Moisture-resistant element with excellent tone quality
- Convenient, minimally-obtrusive design
- Available for use with most wireless transmitters
- XLR connector
- 50Hz–20kHz frequency response

- E6IHW** tan hard-wired omnidirectional version #COE6IHW.....**\$359.95**
- E6IUHW** tan hard-wired unidirectional version #COE6IUHW.....**\$454.95**

**SHURE**  
**WH20XLR**

#SHWH20XLR  
**\$74.95**

Ideal for active microphone users, especially aerobic and dance instructors, the Shure WH20 is a lightweight yet durable cardioid headset microphone that accommodates any head shape or size easily. It is capable of handling high vocal levels without clipping and delivers a smooth, natural response similar to dynamic handheld mics.



- Lightweight and durable without bulky appearance
- Collapsible mic boom for easy storage
- Reliable through temperature and humidity extremes
- XLR connector • 50Hz–15kHz frequency response

**WH20QTR** with right-angle 1/4" connection for any unbalanced mic input #SHWH20QTR.. **\$79.50**

**WH20TQG** with miniature four-pin female 4-pin mini connection #SHWH20TQG ..... **\$79.50**

**SHURE**  
**WBH53**

#SHWBH53B  
**\$299.00**



The WBH53 is a wireless omnidirectional condenser microphone designed for inconspicuous headworn use. It can be exactly positioned on either the left or right corner of the mouth and combines a flexible wire frame with lightweight modular headband and soft earpieces for superior comfort. The Beta 53 mic itself has the sound quality, extended response and performance consistency required for professional productions.

- Headworn omnidirectional condenser microphone
- Provides excellent sound with minimal visibility
- Comfortable, latex-free Dynaflex earforms
- Available with TA4F or no connector for full wireless compatibility
- 20Hz–20kHz frequency response

**CROWN**  
**CM311A**

#CRCM311A  
**\$259.95**

Extremely popular among many of today's top live Pop, R&B, and Country performers, the CM-311A is the industry standard headworn electret condenser microphone. It combines Crown's Differential Cardioid technology with a fully-adjustable, behind-the-ear design, resulting in a truly comfortable headworn mic that effectively isolates the vocal source from unwanted background noise.



- Industry standard headworn microphone
- Crisp, clear vocal response with little unwanted noise • Electronically controlled bass roll-off • XLR connector • 50Hz–17kHz frequency response

**CM311AE** unterminated for wireless transmitter of your choice #CRCM311AE ... **\$229.95**

**AUDIO-TECHNICA**  
**Pro 8Hex**

#AUPRO8HEX  
**\$79.95**

The AT Pro 8Hex is an ideal hypercardioid headset microphone for musicians who need accurate hands-free vocal performance. Its stable, cushioned support provides a comfortable fit, while the pivot-mounted flexible mic boom descends from either the left or right side. Its efficient neodymium element provides a hotter signal without distortion, further isolating the mic from unwanted noise.



- Ideal for guitarists, drummers, keyboardists, and others who need hands-free performance
- Comfortable, stable, less noticeable
- Hi-Energy neodymium element with hypercardioid pattern • Permanently-attached cable between mic and XLR(M) connector
- 200Hz–18kHz frequency response

**PRO8HEcW** 55" cable terminated with locking 4-pin connector for AT UniPak systems #AUPRO8HEcW ..... **\$92.95**

**AUDIO-TECHNICA**  
**ATM75**

#AUATM75  
**\$142.95**



The ATM75 is a professional cardioid condenser headset microphone designed to provide hands-free operation. Its low-visibility headband features a pivot-mounted flexible mic boom and low-noise element that's capable of descending from either side and is battery- or phantom-powered from its belt-mounted power module.

- Professional-quality, front-of-mouth vocal pickup
- Cardioid element effectively isolates the source reducing unwanted noise
- Integrated 80Hz high-pass UniSteep filter
- XLR connector • 100Hz–13kHz frequency response

**ATM73A** side-of-mouth pickup (40Hz–15kHz) #AUATM73A..... **\$181.95**

**ART****MacroMIX 4**

This versatile four-channel line level mixer features both stereo RCA and 1/4" input options with RCA output, providing a simple way of combining multiple sources.

- Active preamplification and mixing circuitry
- Headphone jack for mix monitoring
- Includes 12V power adapter



#ARM4C  
**\$55<sup>00</sup>**

**ART****ProMIX**

Each channel of this three input microphone mixer has both phantom power and low-frequency cut selectable via DIP switches plus a level control.

- (3) low-impedance XLR microphone inputs
- (1) XLR and (1) 1/4" Phones/Aux. output
- Includes 12V power adapter



#ARPM3  
**\$89<sup>00</sup>**

**ROLLS****MX44s**

This unit is designed to mix up to four stereo line-level signals such as instruments, CD players, DVD players, MP3 players, laptop computers and the like, to a single stereo output.

- (4) 1/4" and (4) 1/8" TRS input jacks
- Linear faders and power on LED • Powered by 9V battery



#ROMX44S  
**\$74<sup>95</sup>**

**ROLLS****MX42**

The MX42 is a fantastic passive solution for mixing four RCA-connected devices to a common output, with individual level control for each.

- (4) stereo RCA input pairs
- (1) stereo RCA output pair
- May be used as a stereo 1-in/4-out box



#ROMX42  
**\$54<sup>50</sup>**

**ART****PowerMIX 3**

This simple stereo mixer can accept either mono or stereo signals and mixes them down to stereo or identical L/R mono signals. Its headphone output provides its own level control.

- (3) input channels with individual level and pan control
- (3) sets of left/right unbalanced 1/4" inputs
- Includes 12V power adapter



#ARSM3  
**\$80<sup>00</sup>**

**ART****PowerMIX 1**

The PowerMIX 3 can be used anywhere a compact and simple four-channel passive 1/4" line mixer is needed. There are rotary level controls for each input.

- (4) TS 1/4" phone inputs
- (1) TS 1/4" phone outputs
- Passive operation, no power needed



#ARPM4  
**\$35<sup>00</sup>**

**ROLLS****MX41b**

The MX41b is a four channel, stereo passive mixer for expanding console mixers, mixing instruments, CD or cassette players, or other instruments.

- (4) 1/4" TRS line level input jacks
- (1) 1/4" TRS line level output jack
- Requires no batteries or external power



#ROMX41B  
**\$54<sup>50</sup>**

**ROLLS****MX34 LiveMIX**

The MX34 LiveMIX is a dual-channel microphone preamplifier that features individual level control for each channel, as well as headphone monitoring.

- (2) XLR inputs with Phantom Power
- (1) TRS 1/4" stereo phone output • Powerable by two 9V batteries



#ROMX34  
**\$97<sup>50</sup>**



## BEHRINGER MX400

Whether you are running short on available channels or just looking for a compact line level mixer for your toolbox, the four-channel MX400 is sure to be an excellent solution.

- (4) TS 1/4" mono phone inputs
- (1) TS 1/4" mono phone output
- Includes 12V external power supply



#BEMX400  
**\$19<sup>99</sup>**

## ROLLS MX51 MiniMix 2

The MX51 is a small four-channel mixer that features individual volume controls for each channel and a separate headphone/line output control.

- (2) 1/4" TS and (6) stereo RCA inputs
- (1) stereo RCA output pair, mono signal
- Includes 12V power adaptor



#ROMX51  
**\$58<sup>95</sup>**

## ROLLS MX22A Mini-Mix

The MX22A can combine a single 1/4" input with a stereo pair of RCA inputs, making it perfect for mixing a wireless microphone and CD player.

- (1) TS 1/4" mono phone input
- (2) RCA inputs and (2) RCA outputs
- Great choice for aerobics studios



#ROMX22  
**\$54<sup>50</sup>**

## ROLLS MX54s Pro-Mix Plus

The Pro Mix Plus features three XLR inputs, each with individually switchable phantom power, low cut switches, level control, and pan positioning. Its dual 9V batteries are easily accessible for quick changing.

- (3) XLR microphone inputs with phantom power
- (2) XLR outputs with mic/line level output
- Metal construction with power and clip LEDs



#ROMX54S  
**\$119<sup>95</sup>**

## EDIROL M-10MX

This tiny powerhouse packs loads of inputs into a very portable package with added benefits of 24-bit/96kHz optical and coaxial S/PDIF outputs.

- (6) 1/4" phone and (6) RCA inputs
- (2) 1/4" phone, (2) RCA, Coaxial & Optical digital outputs
- Battery or AC powered (adaptor included)



#EDM10MX  
**\$119<sup>00</sup>**

## ART PowerMIX 2

The PowerMIX II solves the inherent problems of mixing the mono output of a mixer or wireless microphone receiver with recorded music, and sending it all to one mixer channel, a single amplifier input, or a powered speaker.

- (1) 1/4" and (2) RCA line level inputs
- (1) 1/4" stereo and (2) RCA outputs
- Includes 12V power adaptor



#ARM2  
**\$45<sup>00</sup>**

## ROLLS MX56c MiniMix A/V

The MX56c is ideal for A/V presentations where a microphone must be mixed with a variety of sources such as a CD player, MP3 player, or laptop computer.

- (1) x 1/4" TS phone, 1/8" stereo, XLR, stereo RCA inputs
- (1) x 1/4" TRS phone, 1/8" stereo, stereo RCA outputs
- Capable of operating on a single 9V battery



#ROMX56C  
**\$87<sup>95</sup>**

## ROLLS MX28 MiniMIX 6

The MX28 is a three-channel, true stereo mixer designed for keyboards or other stereo line level signal mixing that offers separate level and pan control for each input pair.

- (6) 1/4" TS phone inputs
- (2) 1/4" TS outputs and (2) 1/4" headphone outputs
- Includes 12VDC power adaptor



#ROMX28  
**\$89<sup>95</sup>**

## ALESIS Multimix 12R

#ALMM12R  
**\$299<sup>00</sup>**



The Alesis MultiMix 12R is a 12-channel analog audio mixer equipped with 8 high-gain low-noise balanced mic/line inputs, 2-band EQ per channel, and built-in 28-bit digital effects. Housed in a 3U rackspace chassis, this ruggedly-constructed, small-format mixer is well suited for PA, AV carts, and distributed sound applications.

- (8) balanced XLR and (12) balanced 1/4" line inputs
- (8) Insert points for dynamics processing
- 2-Band EQ per channel and (11) 60mm faders
- Rear-mounted power and 48V phantom power switches
- Easy to use, intuitive layout, and functional design

## TAPCO M50

#TAM50  
**\$44<sup>95</sup>**



The M50 is an ultra-compact 5-channel mixer for desktop A/V production, DJ, school, club, and restaurant applications. The rugged little unit is equipped with an XLR microphone input with 2-band EQ, Main and Control Room outputs, 2 stereo line channels with 3-band EQ, and durable, easy-access control knobs.

- 5-channel compact mixer
- XLR microphone input with 2-band EQ
- Dual 1/4" phone stereo line inputs with 3-band EQ
- Main, Control Room, and headphone outputs
- Very lightweight

## ASHLY MX508

#ASM508  
**\$1260<sup>00</sup>**



The Ashly MX-508 is a high quality eight-input rackmount mixer ideally suited for a multitude of uncomplicated audio applications. Equipped with ultra-low-noise circuitry, transparent mic preamps, and highly responsive tone controls, the MX508 yields outstanding sonic results, flexibility, and performance.

- (8) XLR mic/line Inputs and global 48V phantom power
- Low-noise mic preamp circuitry
- Insert points for creative dynamics processing
- Three-band EQ on each Input
- (2) XLR Transformer-balanced outputs
- (2) TRS 1/4" balanced outputs

## SOUNDCRAFT Compact 4

#SOC4  
**\$99<sup>99</sup>**



The versatile Soundcraft Spirit Compact-4 is a high quality, compact 4-channel mixer with clean, transparent sound meeting the needs of multimedia facilities, small personal performances, and mobile mixing applications.

- (2) balanced low-noise XLR/line inputs with 3-band EQ
- (2) Stereo instrument inputs with switchable RIAA pre-amps for turntables
- 8-segment stereo peak LEDs
- Separate stereo record and mix outputs
- Quality sonic performance
- 48V phantom power

## BEHRINGER XENYX 502

#BEX502  
**\$44<sup>99</sup>**

Simple and compact, the Xenyx series is a continuation of the popular Behringer UB series. The 502 features one mic and line channel with EQ, and two stereo line level channels. It has separate volume controls for the main and headphone outputs. An RCA line input is included to connect a CD or MP3 player, as well as an output for recording. It's an ideal mixer for portable live sound and production.

- (5) total inputs, (1) XLR, (5) line level TRS
- (2) Main outputs TRS
- Stereo RCA line level input and output
- 2-band EQ on mono channel, Pan pot on channels 1, 2/3, 4/5
- 4-segment LED meter





**BEHRINGER**

**UBB1002 Eurorack**

The Behringer UBB1002 is a small-format, 10-channel mixer that provides users with portability and versatility. Featuring 5 ultra-low-noise mic preamps, mono and stereo input channels, two inserts, aux sends, and unique dual powering options, the UBB1002 is ideal for musicians recording at home or performing in small venues.



#BEUBB1002  
**\$99<sup>99</sup>**

- (5) Ultra-low-noise mic preamps with 48V phantom power • Multiple input capability
- Dedicated inserts on all mono channels ideal for dynamics processing
- Stereo channels have separate gain controls for mic/line inputs, allowing both inputs to be active simultaneously • 3-band EQ per channel
- 9V battery or AC powering option

**SOUNDCRAFT**

**Compact 10**



#SOC10  
**\$179<sup>99</sup>**

The Soundcraft Compact 10 is an affordable 10-channel, small-format desktop mixer that offers users intuitive hassle-free operation. The Compact 10's controls and connections are organized to give clear, uncluttered access to all of its functions and inputs, resulting in a versatile work surface ideal for PA, small broadcast, or recording applications.

- (4) High-quality mic preamps with 48V phantom power
- 3-band EQ on all input channels
- On board DI for bass, guitar, and keyboards
- Phono inputs and ground stud for turntable connectivity
- Separate mix, monitor, and record outputs • Extremely easy to use

**SAMSON**

**MDR6**

The Samson MDR6 is a clean, compact 6-channel mixer. Its simple but flexible design includes four Neutrik combo jack inputs, 3-band EQ per channel, and a unique Hard Disk Recording mode that allows easy routing of two channels of audio to and from a computer. Ideal for streamlined computer recording setups and small personal PA mixing.



#SAMDR6  
**\$119<sup>00</sup>**

- (4) XLR 1/4" Neutrik Combo Jack and dual 1/4" input connectors • 3-band EQ section on every input channel
- HDR mode uses 2-track I/O to route channel signal to and from external recorder
- Stereo aux send and return • 48V phantom power

<b>MDR16</b> 16-channel mixer w/24-bit DSP Effects & 7-band Graphic EQ	
#SAMDR16 .....	<b>\$449.00</b>
<b>MDR10</b> 10-channel mixer #SAMDR10 .....	<b>\$299.00</b>
<b>MDR8</b> 8-channel mixer w/24-bit DSP Effects #SAMDR8 .....	<b>\$229.00</b>

**BEHRINGER**

**XENYX 802**



#BEX802  
**\$59<sup>99</sup>**

The Xenyx 802 packs lots of features into a small footprint. With two XLR microphone inputs featuring the redesigned XENYX preamps, and an improved 3-band EQ, plus FX send knobs on every channel, the 802 is equipped for a variety of applications from portable PA, to production sound monitoring and recording. RCA inputs and outputs are included for adding a CD or MP3 player.

- (8) total inputs, (2) XLR, (6) line level TRS
- (2) Main outputs TRS, (2) Control room outputs TRS
- Stereo RCA line level input and output
- 3-band EQ on every channel, FX send knob on every channel • +48V Phantom Power, 4 segment LED meter

**TAPCO BY MACKIE**

**BLEND 6**

An affordable compact 6-channel mixer, the Tapco Blend 6 is a simple solution for adding mic preamps to desktop computer recording.



#TAB6  
**\$99<sup>99</sup>**

It's surprisingly flexible routing provides an ideal monitoring/mixing setup for soundcards, outboard effects and even small performances.

- (2) XLR mic preamps
- (2) TRS input stereo channels
- Lightweight, portable, and ruggedly constructed
- Global 48V phantom power
- 2-band EQ on all channels
- 9-VAC external power supply



**TAPCO**  
**Mix-220FX**

#TAM220FX  
**\$189<sup>99</sup>**



The TapcoMIX-220FX is an affordable small-format mixer that gives big features like built-in 20-bit digital multi-effects, 3-band EQ and overload LED's on each channel, plus the added flexibility of extra alternate output busses. This unit is tough enough for smaller live gigs, churches and schools with easy to understand controls for beginners and pros alike.

- 8 channels with 4 XLR balanced inputs
- Built-in 20-bit digital effects
- Durable solid steel chassis
- Uncluttered control layout for easy use
- 8-segment Main Meters
- RCA CD/ tape I/O • 48V phantom power

**BEHRINGER**  
**XENYX 1204FX**

#BEX1204FX  
**\$169<sup>99</sup>**



With four microphone inputs and the improved XENYX preamps, the 1204FX is a fully-featured compact mixer that's perfect for live sound, recording, and production. A 24-bit onboard effects processor is included to sweeten vocals. A USB audio interface is also included so you can record directly into a PC or Mac. It includes Line level inputs to patch in your MP3 or CD player.

- (12) total inputs, (4) XLR, (12) line level TRS
- (2) Main XLR outputs, (2) Control room TRS outputs, (2) Alt. TRS outputs
- Stereo RCA line level input and output
- +48V Phantom Power, 8-segment LED meter
- USB audio interface included, Mac and PC compatible

**ALESIS**  
**MultiMix 12USB**

#ALMM12USB  
**\$249<sup>00</sup>**



The Multimix 12USB is a high-quality, compact twelve-input mixer that includes a built-in 28-bit digital effects processor and a USB connection for direct integration with a computer. Perfect for audio/video computer workstations, the Multimix 12R provides four microphone inputs with up to 50dB of gain, four mono 1/4" inputs, and four stereo pairs of 1/4" TRS inputs, and includes Steinberg's Cubase LE , a powerful Audio/MIDI recording software package.

- (12) inputs including: (4) XLR mic, (4) mono 1/4", and (4) TRS 1/4" stereo inputs
- Plug-and-play USB operation under Windows XP and Mac OS X
- 28-bit internal effects with over 100 presets
- Musical 3-band EQ, mute, solo, and 2 aux sends on each channel
- Includes Cubase LE software • Stereo 8-segment LED meters

**MACKIE**  
**1202VLZ3**

#MA1202VLZ3  
**\$299<sup>99</sup>**



The Mackie 1202VLZ3 is a 12-channel mixer utilizing Mackie's XDR2 preamps and re-worked channel EQ sections. Its durability, incredibly quiet circuitry and wide dynamic range have made the VLZ series a standard in live, studio, or broadcast applications.

- Inputs: (4) XLR and (4) 1/4" balanced/unbalanced inputs
- (4) 1/4" balanced/unbalanced stereo pairs
- 3-band EQ • Switchable mic/line outputs
- (2) Aux sends • Main, monitor and ALT 3-4 mute switch outputs

**402-VLZ3** Premium 4-channel Ultra Compact Mixer # MA402VLZ3..... **\$99.99**  
**802-VLZ3** Premium 8-channel Ultra Compact Mixer # MA802VLZ3..... **\$199.99**

**MACKIE**  
**CFX12MKII**

#MACFX12MK2  
**\$549<sup>99</sup>**

Well designed for PA applications, the Mackie CFX12 is a 12-channel analog mixer that features high-headroom mic preamps, 32-bit digital effects, and ultra-quiet, low-noise circuitry. Its routing capabilities, outstanding flexibility, clear sound quality and rugged construction give users the rock-solid performance they desire time and time again.



- (8) mic/line mono, and (2) stereo line channels • 4-band EQ on stereo line channels
- True 4-bus design with direct sub outs and L/R assign • (2) Pre/Post Aux sends and internal/external FX level sends on each channel • 32-bit built-in digital effects
- 9-band stereo graphic EQ

**CFX16MKII** 16-channel version of the CFX12 #MACFX16MK2..... **\$649.99**  
**CFX20MKII** 20-channel version of the CFX12 #MACFX20MK2..... **\$749.99**

**ALLEN&HEATH****ZED-14**#ALZED14  
**\$399<sup>00</sup>**

The ZED-14 is a compact 14-channel mixer with a USB interface, musical 3-band EQ's on each channel with swept midrange, 4 Aux sends, and high-quality custom DuoPre mic preamps with exceptional gain range and control. This versatile and flexible mixer has 6 mono and 4 stereo channels, and 3 dedicated USB switches for directing recording to a PC or Mac.

- 14-channel mixer with USB port for desktop or live recording applications
- 13 independent sources, 10 independent outputs
- Selectable USB routing for computer recording, playback, external effects
- Multiple independent monitoring options
- 99 different controls on front panel
- Two-stage mic preamps with huge 69dB of gain range
- (6) XLR inputs, multiple insert points, RCA and 1/4" line inputs
- Cakewalk Sonar LE Windows recording software supplied

**MACKIE****DFX-12**#MADFX12  
**\$249<sup>99</sup>**

The Mackie DFX-12 is a compact twelve-channel mixer equipped with six quality mic preamps, a musical two-band EQ, 32-bit digital effects, and an integrated five-band graphic EQ. Perfect for gigging musicians and small portable PA setups, the versatile DFX-12 can also be used for karaoke applications by utilizing the onboard "Vocal Eliminator" circuit to reduce lead vocals from prerecorded CD's.



- (6) balanced, low-noise XLR mic inputs
- (12) balanced/unbalanced 1/4" line inputs
- Balanced/unbalanced XLR and 1/4" TRS main outputs
- Global 48V phantom power
- (4) mono, (8) stereo, and CD/tape return faders
- Emac 32-bit digital effects with vocal eliminator circuit

**MACKIE****1402VLZ3**#MA1402VLZ3  
**\$429<sup>99</sup>**

The Mackie 1402VLZ3 is a compact, high-quality 14-channel mixer. Its 6 XDR2 mic preamps, incredibly quiet circuitry, and wide dynamic range have made the VLZ series an industry standard for live, studio, and broadcast applications.

- (6) XLR Inputs and 4 1/4 in. Stereo Channels
- 60mm Logarithmic Faders
- 75Hz Low Cut Filter
- (2) Aux Sends
- Separate Control Room/Headphones Volume Controls
- Balanced and Unbalanced Inputs and Outputs
- Switchable XLR mic/line (+4/-10) outputs

**SOUNDCRAFT****Spirit FX16**#SOSFX16RK  
**\$949<sup>00</sup>**

Ideal for a multiple of sound applications, the Spirit FX16 is a high-performance, 16-channel, 4-bus compact mixer. Its 16 UltraMic/line inputs, 3-band "British" EQ, and built-in digital effects offer users outstanding versatility and a well-defined sound.

- (16) XLR mic/1/4" TRS Line Inputs
- 3-band "British" EQ
- (16) Direct Outputs/Insert Points
- Two sub-group outputs
- Separate mono sum output
- 100mm Long Throw Faders
- Custom-designed pots
- Stereo 18dB/octave 100Hz high-pass filter

**BEHRINGER****XENYX 2442FX**#BEX2442FX  
**\$329<sup>99</sup>**

The 2442FX from Behringer is the flagship of the XENYX series of mixers. With a total of 24 inputs, it features a 24-bit onboard effects processor with 100 presets, 4 aux sends on each channel, and four subgroups with separate outputs. It also includes a USB computer audio interface that's PC and Mac compatible. It's the ultimate inexpensive mixer for live sound and home recording.

- (24) total inputs, (10) XLR, (16) line level TRS
- (2) Main XLR outputs, (2) Main TRS outputs, (2) Control room TRS outputs
- (4) Aux sends, (4) subgroups with separate outputs
- +48V Phantom Power, 12-segment LED meter
- USB audio interface included, Mac and PC compatible



## MACKIE 1604VLZ3



#MA1604VLZ3  
**\$899<sup>99</sup>**

Perhaps one of the most widely used compact mixers to date, the ultra-flexible Mackie 1604VLZ3 is a 16-channel, very low noise mixer. It provides 16 high-quality XDR2 mic pre's, inserts, and 1/4" inputs, and a reworked 3-band sweepable-mid EQ on every channel. Its rugged build, combined with a clean and dynamic sound, have made the 1604 an invaluable tool for live sound and recording engineers worldwide.

- (16) XDR2 mic, (16) 1/4" line inputs, and (16) channel insert points • Balanced 1/4" inputs & outputs
- (6) aux sends per channel, aux 1 & 2 pre/post switchable
- (4) subgroups with left & right assigns and (8) direct outs, (4) stereo aux returns • Ideal for live sound PA, studio recording and mixing, and video post-production suites
- Built-in power supply, rack mount kit included

## MACKIE 1642VLZ3



#MA1642VLZ3  
**\$649<sup>99</sup>**

Featuring superior sound quality, flexibility and value, the solidly built Mackie 1642VLZ3 is an ideal general-purpose mixer. Its comprehensive connectivity, routing and monitoring make the 1642 a great, simple-to-use choice for either eight-track location recording or computer-based audio/midi setups.

- High-headroom, extended dynamic range preamps with great clarity and definition • (10) XDR2 mic inputs (8 mic/line, 2 stereo mic/line, and 2 stereo line inputs)
- 3-band EQ on mono channels, and 4-band EQ on stereo channels • Balanced inputs & outputs
- (8) TRS channel inserts • (4) aux sends, (4) stereo aux returns, and (8) direct outs
- (4) subgroups with left & right assigns

## ALLEN & HEATH GL2400-32

Derived from the hugely successful GL2200, the versatile GL2400-32 is a professional 32-channel 4-bus sound reinforcement mixing console. While its new circuit design provides an ultra-quiet mix head amp, improved preamp headroom, and greater EQ responsiveness, the GL2400's dual functionality offers uncompromised mixing for FOH, stage monitors, or both. Affordably priced and expandable, the GL2400-32 is ideal for live music venues and houses of worship.

- (32) XLR mic inputs with insert points • 4-band "British" EQ
- L/R and M outputs with M configurable as LR sum, Wedge, or Aux-Fed Sub or C Master
- (2) stereo grouped channels with XLR mic and dual stereo line inputs
- (6) auxiliary sends, 7 x 4 matrix output • Expandable via Syslink input/output option
- Pink Noise Generator & Test Tone Oscillator

#ALGL240032  
**\$2499<sup>00</sup>**



## SOUNDCRAFT Spirit Live 8



#SOL824  
**\$3599<sup>00</sup>**

The Spirit Live 8 is a 24-channel, 8-buss sound reinforcement mixing console with 24 balanced XLR mic and 1/4" line inputs and 2 stereo line inputs. The mixer features musical 4-band mono-channel EQ's with 2 sweepable mid-range sections, and Soundcraft's UltraMic+ preamps, which provide a wide 66dB of gain. This rugged, compact and affordable console is a viable FOH solution for clubs, small theaters, and houses of worship.

- (24) mono and (2) stereo inputs • (8) subgroup outputs
- Matrix Mixer for enhanced output routing flexibility • 100mm Faders, (6) Aux sends
- (24) Direct outputs on all mono channels • UltraMic+ mic preamps with wide 66dB of gain range • Solo and Mute for all input channels

## SOUNDCRAFT/SPIRIT EPM12

The EPM12 features high build quality, great audio performance and an uncluttered control surface for an attractive price. This 12-channel workhorse is designed with surface-mount technology throughout and uses close-tolerance components for high accuracy and repeatable settings for EQ and gain controls. The highly-transparent GB30 Mic amp (designed by Graham Blyth for the company's 30th anniversary and also used on their larger consoles) features high-resolution adjustment over a wide gain range of 55dB, and provides a stunning +22dB headroom through the board.

#SOEPM12  
**\$429<sup>00</sup>**



- (12) XLR mic and (12) 1/4" TRS phone line level inputs
- (2) Stereo 1/4" TRS phone line level channels • (2) XLR balanced outputs
- 3-band EQ with a swept mid on mono inputs • Ten-segment LED output metering



**SOUNDCRAFT****LX7ii**

#SOLX7224  
**\$1799<sup>00</sup>**

- (32) mono inputs and four stereo inputs/returns
- 4-band "British" EQ
- (6) aux sends, 7-bus
- Group and Mix inserts
- Multi-functional use as either FOH or monitor mix console
- Direct channel outputs allow for connection to multitrack recording devices

Combining the essential features of both live and recording-oriented mixers, the Soundcraft LX7ii series is among engineers' favorites worldwide. Available in 16-, 24-, and 32-channel formats, the rugged LX7 provides clean, wide-range audio from its low-noise preamps, precise 4-band sweepable EQ's per channel, and very flexible routing and monitoring configurations. An ideal console for live music venues, houses of worship, and live/studio recording.

**SOUNDCRAFT****Spirit Live 4<sup>2</sup>**

The Soundcraft Spirit Live 4<sup>2</sup> is a medium-format, 24-input live sound reinforcement console with 20 low-noise, high-gain UltraMic+ preamps, two dual stereo inputs, 4-band "British" EQ, four busses and six aux sends. Its 6x2 output matrix provides outstanding routing flexibility, giving engineers precise control over multi-way speaker systems or additional independent zone or monitor mixes. Combining world-class performance with clear detailed sound quality, the Spirit Live 4<sup>2</sup> is an ideal solution for permanent installations in live performance theaters and houses of worship.



#SOG8824  
**\$4699<sup>00</sup>**

- (20) Balanced XLR UltraMic+/ 1/4" TRS line inputs
- 4-band "British" EQ with (2) swept Mid-frequency bands
- 48V phantom power & Phase Reverse switching on all Mono mic inputs
- 1/4" TRS Insert points on all Mono inputs and Stereo Master output
- (6) Aux Sends, 4 of which are Pre/Post switchable
- Available in 12, 16, 32 and 40-channel frame sets

**ALLEN & HEATH****GL2800-32**

#ALGL2800832  
**\$4999<sup>00</sup>**

- 4 band, 2 sweep EQ section
- 100mm dust protected faders
- (10) Aux Sends, 12x4 Matrix, (8) audio groups with pan and routing, LR and M mix busses
- Dual functionality as FOH or monitor mixer
- Mutes on all fader masters
- 74dB range preamp, 34dB input capability for mic or line

**GL2800848** 48 input version #ALGL2800848.. **\$6999.00**

The GL2800 series from Allen & Heath is an extremely flexible, medium-format, live sound mixing console. It excels in FOH or as a well-equipped multi-output monitor mixer capable of 14 mixes. Delivering premium audio performance and rugged durability, it's been designed to adapt to the changing needs of today's performers and the complexity of managing multiple in-ear monitoring systems.

**SOUNDCRAFT****MPM 12**

#SOMPM122  
**\$549<sup>00</sup>**

The MPM series from Soundcraft focuses on premium sound and build quality. These mixers were designed with flexibility in mind, whether being used as part of a sound installation, a portable PA system, or the front end of a recording setup, the user will have complete control over their sound. Soundcraft is known for delivering excellent-sounding equipment, and this tradition is apparent in the MPM.

- (2) group busses, (3) configurable Aux busses
- 3-band EQ with swept Mid band
- Peak LED and signal present LED
- GB 30 Mic Preamps, 100 Hz High-Pass Filter
- +48V Phantom Power, Insert points, PFL switch
- Universal power supply

**MPM122RK** Same 12-channel version with included rack mount kit #SOMPM112RK ..... **\$579.00**

**MPM202** 20-channel version #SOMPM202.. **\$759.00**

**ALLEN & HEATH****MixWizard3 16:2**

#ALWZ3162  
**\$999<sup>00</sup>**

The compact Allen & Heath MixWizard3 16:2 is a great sounding 16-channel, medium-format mixer. Its modular, slim-line design, transparent mic pre's, and highly responsive 4-band "British" EQ and digital effects, make the MixWizard3 ideal for a wide variety of live sound applications.

- (16) mic/line inputs
- 4-Band EQ with HPF
- Expandable via Syslink II output option
- (16) Direct outputs
- Separate internal power supply module

## YAMAHA 02R-96V2

#YA02R96V2  
**\$9299<sup>00</sup>**

Combining five times the processing power of its predecessor, the pristine preamps derived from Yamaha's flagship console DM2000, and extensive remote functionality control via custom Stage Manager Software, the 56-channel Yamaha 02R96V2 sets the new standard for medium-format digital consoles. It delivers uncompromised 96kHz performance over all channels simultaneously, adds more physical controls for quicker, more intuitive operation, and provides comprehensive routing, dynamics, and effects with full recall automation. A perfect live or studio mixing/recording console.



- (24) balanced 1/4" TRS line, (16) balanced XLR Mic switchable inputs
- 32-bit internal processing with high-quality Compression, Gating, EQ, and Digital Effects per channel
- High-quality effects and dynamics virtually eliminate the need for outboard processing
- I/O expandability via six Mini-YGDAI expansion slots
- Extremely intuitive work surface and GUI for maximum productivity
- Comprehensive Automation and Scene Control
- Mac/PC compatible Studio Manager V2 software allows complete control of console parameters
- Integrated DAW control creates a complete production and mixing environment (surround capable)



## YAMAHA Mini-YGDAI expansion cards For 02R96 & 01V96

<b>Y96K</b> High-performance Waves DSP card #YAY96K.....	<b>\$999.00</b>
<b>MY16AT</b> 16-Channel ADAT I/O Card #YAMY16AT .....	<b>\$449.00</b>
<b>MY16AE</b> 16-Channel AES/EBU I/O Card #YAMY16AE.....	<b>\$579.00</b>
<b>MY16TD</b> 16 TDIF I/O Card #YAMY16TD.....	<b>\$449.00</b>
<b>MY8AD96</b> 8-Channel 96kHz Analog Input Card #YAMY8AD96 .....	<b>\$429.00</b>
<b>MY8AE96</b> 8-Channel 96kHz AES/EBU I/O Card #YAMY8AE96 .....	<b>\$429.00</b>
<b>MY8DA96</b> 8-Channel Analog Output Card #YAMY8DA96 .....	<b>\$379.00</b>
<b>MY8AE96S</b> 8-Channel AES/EBU I/O Card w/sample rate conversion #YAMY8AE96S.....	<b>\$569.00</b>
<b>MY8AT</b> 8-Channel ADAT Light Pipe I/O card #YAMY8AT.....	<b>\$299.00</b>
<b>MY8TD</b> 8-Channel TDIF digital I/O card #YAMY8TD.....	<b>\$299.00</b>
<b>MY8AE</b> 8-Channel AES/EBU digital I/O #YAMY8AE .....	<b>\$299.00</b>
<b>MY4AD</b> 24-bit analog input card via 4 balanced XLR connectors #YAMY4AD.....	<b>\$299.00</b>
<b>MY4DA</b> 20-bit analog output card via 4 balanced XLR connectors #YAMY4DA.....	<b>\$249.00</b>
<b>MY8AD24</b> 24-bit analog input card via 8 1/4" phone connectors #YAMY8AD24.....	<b>\$349.00</b>
<b>MY16mLAN</b> 8-Channel MLAN I/O card #YAMY16MLAN.....	<b>\$389.95</b>

## TASCAM DM-3200

#TADM3200  
**\$2999<sup>00</sup>**

The Tascam DM-3200 is a 48-channel digital mixing console that provides high-resolution, 24-bit/96kHz operation without sacrificing inputs, processing power or performance. This highly expandable and flexible mixer can be used easily as the audio interface for your computer via its optional FireWire interface. Backup/restore of mixer data, meter display, and future expandability is available using Tascam's Mixer Companion software for MAC or PC remote control, making it suitable for professional recording, post-production, film scoring, and installation applications.



- (16) balanced mic/line inputs
- 4-band fully-parametric EQ and dynamics on every channel
- Seamless DAW integration for total control of popular programs
- (24) channels of TDIF and (8) channels of ADAT
- Expansion card slots support optional FireWire, ADAT, AES/EBU, Analog & TDIF cards
- Dedicated cascade port supports cascade of two DM-3200's
- Expanded mix storage using compact flash media

## YAMAHA 01V-96V2

#YA01V96V2  
**\$2199<sup>00</sup>**



The Yamaha 01V96V2 is a full-featured, 24-channel 24-bit/96kHz digital audio mixer designed to integrate easily into today's digital audio workstations. It features a truly dynamic, transparent sound, expandable analog and digital connectivity (surround capable), and fully-automated routing, effects and dynamics suited well for studio production, live sound, and broadcast applications.

- (16) balanced 1/4" TRS line, (12) balanced XLR Mic switchable inputs
- Full automation of routing, 32-bit effects and dynamics
- Easy digital recording workstation integration (ProTools, Nuendo and more)
- ADAT Light Pipe, Tascam TDIF and AES/EBU I/O Expandability
- Layer switching for easy navigation of hidden channels
- Version 2 software features Add-On Effect capability, advanced DAW support and control
- Up to 20-bus configuration capability for a multitude of signal routing options



**ALESIS**

**MultiMix 8 FireWire**

#ALMM8FW  
**\$299<sup>00</sup>**

The MultiMix 8 FireWire is an 8-channel analog mixer with a built-in, 24-bit multi-channel FireWire audio computer interface. It is equipped with 4 high-gain mic/line (XLR and 1/4" balanced) inputs with phantom power, 2 stereo balanced 1/4" line inputs, an aux send (can be sent to onboard or external effects), a stereo aux return and smooth 60mm faders.



- 8-channel mixer with integrated FireWire Interface
- Built-in 28-bit digital effects processor
- 3-band EQ per channel
- 24-bit, 44.1/48 kHz operation w/ high-end A/D and D/A conversion
- Separate 1/4" balanced main and monitor outs, headphone out
- Includes Steinberg Cubase LE software
- Compatible with Mac OSX and Windows XP

**MACKIE**

**TT24**

#MATT24  
**\$5999<sup>99</sup>**

The Mackie TT24 is an extremely flexible 24-bit/96kHz digital medium-format mixer designed specifically to offer the best of both the live and studio worlds. Expansive analog connectivity, easy detection anti-feedback filters, and a single-button press turn this powerful, fully-automatable, DSP-based console into a full-fledged live sound/monitor mixer with complete production-studio quality effects and dynamics. Remote controllable via TT Control software, the TT24 is the ideal mixer package for today's sound professional in clubs, theaters, and houses of worship.



- (24) high-quality mic/line inputs w/4-band Parametric EQ/Comp/Gate
- Quick Mix section featuring 5-inch touchscreen LCD
- Anti-feedback Filters for quick and easy feedback detection and elimination
- 99 snapshots instantly recall levels, dynamics processing, EQ, routing, and mutes
- (12) Stereo Linkable Aux sends with 4-band Parametric EQ and Dynamics Compression that allow up to six stereo in-ear mixes
- USB connectivity for Windows XP/2000 Laptop Operation
- TT Control software for console control and operational monitoring
- Dual console linking option available for up to 96 channels of mixing capabilities
- Four Internal Effects Processors

**Onyx 800R** 8-Channel rackmount Mic preamp  
#MAO800R ..... **\$1099.99**

**MACKIE**

**Onyx 1640**

#MAO1640  
**\$1399<sup>99</sup>**



The Mackie Onyx 1640 is a multifunctional, 16-channel analog hybrid audio mixer that integrates seamlessly into recording and production facilities while presenting itself as the ideal small-to-medium format location recording/live sound console.

Featuring high-quality connectivity via Mackie's Onyx Firewire card option, precision crafted low-noise circuitry, and offering a variety of outputs, the Onyx 1640 is readily adaptable to any high-performance audio application.

- (16) Onyx XLR mic and 1/4" TRS Balanced and Unbalanced Inputs
- 4-bus architecture offers flexible sub-grouping of channels
- Optional 96kHz Firewire Card Allows 18 channels of Digital I/O
- Balanced Direct Out via DB-25 Connection
- "Planet Earth" Switching Power Supply for worldwide use
- Tape I/O, XLR and 1/4" TRS main outputs
- Individual 48V phantom power

**Onyx Firewire Option** #MAOFC ..... **\$449.99**

**MACKIE**

**Onyx 1620**

#MAO1620  
**\$849<sup>99</sup>**



With a great analog sound and optional digital connectivity, the Mackie Onyx 1620 is a high-quality, 16-channel analog hybrid recording console designed to interface easily into a computer via an

optional Firewire interface. Its eight newly-designed Onyx mic preamps and Perkins EQ's are evidence of the care given to deliver consistently better sound and flexibility from input to output than almost any other mixer near its price range.

- (8) Onyx XLR mic and (4) balanced 1/4" Stereo Inputs
- 4-Band Perkins "British" EQ with Dual-Sweepable Midrange
- Optional 96kHz Firewire Card allows 18 channels of Digital I/O
- Balanced Direct Out via DB-25 Connection
- "Planet Earth" Switching Power Supply for worldwide use
- Individual 48V phantom power
- Selectable Instrument Inputs on Channels 1 & 2

**Onyx 1220** 12-channel version #MAO1220 ..... **\$549.99**  
**Onyx Firewire Option** #MAOFC ..... **\$449.99**



## TECHNICS SL-1200 MK2

#TESL1200MK2  
**\$449<sup>00</sup>**

Since 1978, the SL-1200 MK2 has built a solid reputation for being an incredibly durable piece of equipment that promises to keep the music playing no matter what you throw at it. Its heavy aluminum body and thick rubber base make it impervious to vibration. The platter itself is an integrated component of its direct-drive motor, increasing its resiliency and making speeds more accurate.

- Accurate quartz locked pitch adjustment 16%(+/-8)
- High-torque/low-speed motor, starts and stops in 0.7 seconds
- Variable pitch, 33 1/3 and 45 RPM
- Cartridge not included
- Industry standard DJ turntable
- Dust cover, headshell, rubber platter mat, and 45 RPM adapter included
- Cartridge and stylus (needle) not included
- 26.5 lbs, 17-27/32" x 6-25/32" x 13-31/32"



## TECHNICS SL-1210M5G

#SL-1210M5G  
**\$599<sup>95</sup>**

The SL-1210M5G incorporates all of the classic characteristics that have made the 1200 the standard for DJ worldwide, while adding a few more useful improvements over the original. The pitch is controlled digitally, insuring accuracy from deck to deck. The brake speed is adjustable, the lamps have been replaced with long life blue LED's, and the black brushed steel body is easy on the eyes.

- Classic quartz direct-drive
- Silver Technics head shell
- Adjustable electronic brake speed
- 33 1/3 and 45 RPM
- Easily replaceable pitch controller
- Tonearm and cabling produces better sound
- High torque for fast start times
- Cartridge and stylus (needle) not included
- 25.74 lbs, 17-27/32" x 6-25/32" x 13-31/32"



## TECHNICS SL-DZ1200

#TESLDZ1200  
**\$799<sup>95</sup>**

Designed from the ground up to bring the look and feel of a classic SL-1200 turntable into the digital realm, the SL-DZ1200 features a familiar feeling direct-drive motor with a 10" spinning platter. Play back and scratch CD's, MP3's, and AAC's on a disc or in the SD memory card slot. You can sample and loop a portion of the music playing quickly with "in" and "out" pads, and even edit and overlap the samples.

- Same quartz crystal direct-drive as the classic SL-1200
- (4) illuminated cue pads
- Forward/reverse instantly play backwards on the beat
- 12.8 lbs, 43/8" x 1239/64" x 13"
- Change tempo with changing pitch
- Adjustable brake and start up times
- Central display shows BPM, elapsed + remaining time, song data



## NUMARK X2

#NUX2  
**\$999<sup>95</sup>**



The X2 has answered the call for an integrated DJ deck featuring both a professional vinyl turntable, and a CD/MP3 player with looping and scratching capabilities. It features a beat detection for CD, full MP3 support with scratching, looping, and pitch control, adjustable start and brake, storage for 3000 cue points, instant forward & reverse, and an anti-shock buffer for continuous playback.

- Ability to play vinyl and CD's at the same time
- Interchangeable S and straight tone arms
- Scratch CD's and MP3's with vinyl platter simultaneously
- Sample and loop on the fly
- (3) Outputs: dedicated phono, CD, and switchable
- Illuminated output bay
- Adjustable brake and start up times
- Cartridge and stylus (needle) not included
- 25.4 lbs, 458(L) x 357(W) x 150(H) mm

## NUMARK TTXUSB

#NUTTXUSB  
**\$399<sup>95</sup>**

The TTXUSB is an old-school vinyl turntable with powerful high-tech capabilities. It features an adjustable ultra high torque motor, as well as adjustable startup and brake times. It has a Key Lock feature, which allows you to change the tempo of the record without affecting pitch. It comes complete with a USB output and EZ Vinyl Converter software that allows you to easily transfer your records to a computer.

- 33, 45, and 78 RPM
- 27.7 lbs, 370mm(W) x 460mm(D) x 135mm(H)
- Interchangeable S and straight tone arms
- Output switchable between phono and line
- Includes USB output and EZ Vinyl Converter software
- Adjustable brake and startup times
- Head shell included, cartridge and stylus (needle) not included
- Illuminated output bay
- Super-bright LED target light and strobe



## ART 311

The 311 is an affordable 2-way stereo crossover with an additional subwoofer output for low-end sound reinforcement. It effectively utilizes 24dB/octave state-variable, Linkwitz-Riley filters that ensure properly phased outputs at all frequencies. Each channel features independent high and low output level controls with a 30Hz low-cut switch for eliminating low-end rumble.



#AR311  
**\$89<sup>00</sup>**

- Stereo 2-way crossover
- State-variable 24dB/octave Linkwitz-Riley filters
- Independent high and low output level control
- Subwoofer output with independent level and frequency controls
- XLR and 1/4" I/O



- Outputs assignable to any input
- Crossover, EQ, Delay & Limiter functions
- Programmable by front panel, PC, or MIDI
- Intuitive user interface

- Parametric EQ: full bandwidth, 1/64th to 4 octave range
- (4) Balanced XLR inputs
- (8) Balanced XLR outputs

## ASHLY Protea 4.24C

#AS4.24C  
**\$1435<sup>00</sup>**

Ideal for live or fixed installations, the Ashly Protea 4.24C is a fully-programmable, ultra-functional, digital crossover/system processor. The Protea gives professional engineers all the processing power necessary to control even the most challenging concert venues effectively.

## ASHLY XR2001

#ASXR2001  
**\$360<sup>00</sup>**

The XR2001 is a precision stereo 3-way/mono, 4/5-way crossover system that's flexible enough to be used in a wide variety of sound systems. Based on a powerful state-variable circuit, the XR2001 features a 24dB/octave filter with independent, infinitely variable adjustments of the crossover frequencies, guaranteeing that two adjacent frequency band outputs remain in phase.

**XR1001** stereo 2-way version switchable to 3-way mono #ASXR1001.. **\$240.00**

**XR4001** stereo 4-way version #ASXR4001..... **\$425.00**



- Stereo 3-way/mono, 4/5-way crossover with 24dB/octave filters
- Ideal for Concert Sound, Night Clubs, Houses of Worship and more
- Exclusive Response Control reduces inherent inaccuracies in typical loudspeakers
- XLR and 1/4" connectors

## BEHRINGER Super-X Pro CX3400

#BECX3400  
**\$129<sup>99</sup>**



The CX3400 is an active frequency crossover capable of 2/3-way stereo or 4-way mono operation. Each band features two 24dB Linkwitz-Riley filters and individual Limiters. Each output provides polarity switches for simple run-time compensation of various horn and driver types, while the built-in delay enables flexible time alignment adjustments.

- Stereo 2/3-way or 4-way mono crossover
- 24dB filters with Limiters
- Individual output control for all bands
- Switchable 25Hz filter on inputs for low-end protection
- Balanced XLR I/O

**CX2310** 2-way stereo and 3-way mono version #BECX2310..... **\$89.99**

## DBX Drive Rack PX Processor

#DBPX  
**\$399<sup>95</sup>**



The Drive Rack PX is a processor specifically tailored for powered speaker applications. It is equipped with Feedback Elimination, Dual 28-band Graphic EQ, 120A Subharmonic Synthesizer, Stereo Multi-band Parametric EQ, Stereo PeakStopPlus Limiters, and a Compressor. This easy-to-setup unit provides Auto-EQ, and AFS Wizards, and out-of-the-box support for a host of JBL and other popular powered speakers.

- Powered Speaker Optimizer
- (2) channel XLR In/Out
- (2) channel XLR Sub Output
- 24-bit ADC/24-bit DAC
- Full graphic LCD display
- 25 user programs / 25 factory programs
- Includes M2 measurement mic

## DBX DRIVERACK PA

#DBPA  
**\$499<sup>98</sup>**

The dbx DriveRack PA is one of the most comprehensive loudspeaker management systems available. Its vast array of integrated sound processors give engineers the tools necessary to achieve a new degree of sonic control.

- Dual 28-band Graphic EQ
- Classic dbx Compressor
- 120A Sub-harmonic Synthesizer
- Alignment Delay
- Stereo Multi-band Parametric EQ and Output Limiting
- (4) Balanced XLR inputs
- (8) Balanced XLR outputs



#DBRTAM  
**\$99<sup>95</sup>**

## DBX DRIVERACK RTA-M

Designed to take advantage of the analyzing features of the DBX DriveRack System, the DBX RTA-M is a highly accurate, flat-measurement microphone. Ideally suited for contractors and engineers in need of precision measurements in permanent install and live sound applications.

- Flat response, omni-directional electret condenser mic
- 15V phantom power
- 22Hz-22kHz frequency response

## DBX DriveRack 220i

#DB220I  
**\$599<sup>95</sup>**

The DriveRack 220i is a 24-bit System Processor that provides a full complement of audio tools for both system and microphone processing. It features Advanced Feedback Suppression (AFS), equalization, dynamics processing, matrix mixing, and bandpass filters. Its intuitive DriveWare software GUI provides Configuration and Control of modules, accessing, editing, and saving of them as part of the program for future recall.



- 24-bit, 2-channel programmable System Processor
- Affordable, multi-purpose audio processor for permanent install applications
- Powerful EQ's on both inputs and outputs
- Outputs offer Time-Alignment Delay, Polarity and Phase control
- Balanced XLR and Euroblock I/O

## DBX DriveRack 480

#DB480  
**\$2999<sup>95</sup>**



The DriveRack 480 is a high-quality EQ and Loudspeaker Management System designed to optimize every aspect of sound systems. The four independent channels of processing power include EQ and Crossover Filters, Real Time Analyzers, Delays, and Dynamics, all of which are controllable via the included dbx Professional Products Interactive DriveWare software. Its flexible operation provides engineers an ideal solution for superior live and install sound.

- 24-bit/48kHz EQ and Speaker Management System
- Dual Real-time Audio Analyzers, Time Alignment, and Speaker Alignment Delays
- Compressor/Limiter on every output
- 31-band graphic or 9-band parametric EQ on every input
- Balanced XLR connectors

## DBX DriveRack 4800

#DB4800  
**\$3749<sup>95</sup>**



The DriveRack 4800 is a professional, customizable 96kHz DSP-based system processor designed to control functions from Signal Routing, EQ and Bandpass Filters, to classic dbx Dynamics and Advanced Feedback Suppression. Combining multiple control surfaces with standard analog and digital I/O, the 4800 delivers the superior audio quality, flexibility, and intuitive control required for even the most discriminating engineers of major live or permanent install sound systems.

- Complete 96kHz Equalization and Loudspeaker Management System
- Full Bandpass Filter, Crossover and Routing Configurations
- Selectable DSP inserts on I/O for Compression, Limiting, Feedback Suppression
- 31-band graphic/9-band parametric EQ on each input, 6-band parametric EQ on output
- Ethernet HiQnet networking and control
- 4 x 8 analog/digital XLR/AES/EBU I/O

**DriveRack4820** tamper-proof version of above #DB4820 ....**\$2999.95**



**ELECTRO-VOICE****Dx38**#ELDX38  
**\$1288<sup>00</sup>**

The Dx38 is an ideal professional sound system processor for integrating room influence, speaker positioning, and parameter settings seamlessly. Utilizing its custom RACE (Realtime Acoustic Cluster Editor) software, the Dx38 model's loudspeaker responds within specific venue measurements and applies the appropriate settings for both simple and complex systems, ensuring an accurate basis to begin system tuning.

- 24-bit/48kHz System Processor with 48-bit internal processing
- Custom RACE software allows extensive control of parameters
- High/low-pass filters with Butterworth, Linkwitz-Riley and Bessel slopes
- (5) filters per input, (4) filters per octave
- Independent Compressors, Limiters, and Time-Alignment Delays
- 2 x 4 XLR I/O configuration with two additional outputs as Direct Outputs

**QSC****DSP-30**#QSDSP30  
**\$519<sup>00</sup>**

The DSP-30 is a 24-bit computer configurable Digital Signal Processor that combines 2-channel processing with a simple two-button, eight-preset selection interface. Its powerful processor provides a wide range of useful system tools including speaker crossovers, time-alignment delays, EQ, mixing, and dynamics control. All processing is assigned dynamically via "drag-and-drop" tools, eliminating the restraints of conventional "fixed-signal" processors.

- 24-bit, 2-channel Configurable Digital Signal Processor
- PC-based Signal Manager software configures multiple processing functions
- Rugged design with simple two-button, eight-preset selection interface
- Graphic representation of DSP resources
- Balanced XLR and 1/4" Combo inputs

**DBX****223**#DB223  
**\$149<sup>99</sup>**

With a majority of its adjustment switches on the back panel, the straightforward dbx 223 is a tamper-proof, 2-way stereo or 3-way mono crossover designed to avoid system changes that could inadvertently destroy a system. The switches provide for system configuration, crossover frequency range, and subwoofer mono summing. Level controls and filter cuts are dedicated to the front panel.

- Stereo 2-way or mono 3-way crossover
- 24dB/octave Linkwitz-Riley filters (flat response)
- Low frequency summed subwoofer output
- Phase reverse switches on all outputs
- Balanced 1/4" TRS connectors

**223XL** same as above w/XLR connectors #DB223XL ..... **\$179.95****234** 2/3-way stereo or 4-way mono version #DB234..... **\$199.95****234XL** XLR version or 234 #DB234XL ..... **\$229.95****RANE****AC22B**#RAAC22B  
**\$375<sup>00</sup>**

The AC22B is a professional 2-way stereo/3-way mono crossover designed with Linkwitz-Riley filter alignments to reduce phase difficulties. The identical phase characteristics on the low- and high-pass outputs, combined with the precise 24dB/octave roll-off slopes, results in proper acoustic summing and frequency ranges that aren't driven past their limits, thereby minimizing distortion and speaker fatigue and improving overall system performance.

- Professional 2-way stereo/3-way mono crossover
- Linkwitz-Riley filter alignment with 24dB/octave slopes
- Mono subwoofer switch and output
- Infrasonic, Ultrasonic, and RFI filters
- Balanced XLR I/O

**AC23B** 2/3-way stereo or 4/5-way mono version of above #RAAC23B..... **\$469.00****RANE****RPM2**#RARPM2  
**\$639<sup>00</sup>**

The RPM2 is a 24-bit DSP-based System Controller with a simple drag-and-drop setup. It utilizes any Ethernet-equipped PC running Windows to draw the system you need without any signal flow restrictions, resulting in superior signal processing flexibility. The RPM2 provides 48-bit internal processing for simple or complex tasks such as Parametric and Graphic EQ's, Automatic Gain Control on inputs, stereo compression, output Limiters, Time-Alignment Delays, and more.

- 24-bit System Controller with 48-bit internal DSP processing
- Drag Net control software provides superior signal-processing flexibility
- Signal flow and critical settings easily viewable from one screen
- Versatile Input Port for remote control via voltage
- Balanced Euroblock I/O with 10Base-T Ethernet control

**SABINE****Graphi-Q2 GRQ-3122**

The GRQ-3122 is a powerful 2-channel, 24-bit digital sound system

processor that combines, into one package, eight indispensable audio products with hands-on analog controls. Utilize the precise parametric EQ, steep crossover filters, time-align your speakers, control system dynamics via digital limiting/compression, and finally, add extra gain and automatic feedback control for ultimate flexibility and audio quality.

- 24-bit Multi-function System Processor with 32-bit internal DSP
- 31-band Digital Graphic EQ w/faders and switchable 6 or 12dB range
- Steep crossover slopes with Bessel, Linkwitz-Reilly and Butterworth filters
- Remote control software manages every function with Bypass and Active matrix
- Balanced/unbalanced TRS/XLR input, Balanced XLR output

**GRQ3122S** same as above with blank face and RS-232 control #SAGRQ3122S... **\$899.99**



#SAGRQ3122  
**\$1049<sup>99</sup>**

**SHURE****DFR22**

The DFR22 is a professional 2-channel system audio processor designed to provide over 10 powerful DSP processes, applied in any order, to any input or output. Utilizing Shure's intuitive setup software, processing block changes and control are easily accomplished in real-time with a simple "drag and drop." This customizable system utilizes up to 16 precision, adaptive notch filters that automatically seek out and reduce problem frequency bands while maintaining the highest audio quality.

- 24-bit Audio Processor and Feedback Reduction
- Precision EQ's, Alignment Delays, Sub Processor, Ducker, Auto Gain Control, and more
- Interface features Design and Live Modes for creating configurations without a computer
- Computer, AMX, or Crestron controller capability • Modular signal processors

**SHURE****P4800**

The P4800 System Processor is a flexible, remote-controlled 24-bit digital audio processor that provides all the necessary functions between the mixers and amplifiers in small-to-medium sized sound systems. Its 4 x 8 matrix mixer and Graphical User Interface allow users to route audio from any input to any output while easily placing EQ's, Alignment Delays, Dynamics, and more at any point in the signal path. Presets can be set up to optimize multiple configurations for multiple audio applications.

- 24-bit System Processor with full 4 x 8 matrix mixer and 128 presets
- 2- to 5-way Crossovers, Ducker, Digital Feedback Reduction, Automatic Gain Control
- Parametric and Graphic EQ
- System control via software and Contact closures, MIDI or RS232 commands
- (2) block terminals included for I/O

#SHP4800  
**\$1822<sup>95</sup>**

**SAMSON****S3-Way**

The S3-Way is a 2/3-way stereo crossover that's even switchable for 4-way mono use. Each output provides a Mute switch for individual frequency band monitoring and a phase switch to invert the phase of the output. To improve system performance and phase response, a time-alignment Delay section with up to 2ms of delay is incorporated into the global section along with a variable threshold Limiter, CD function (for constant directivity horns) and High-Pass Filter.

- Full-featured stereo 3-way, Mono 4-way electronic crossover
- Phase switches invert the phase of individual outputs
- Adjustable low-frequency delay for time alignment
- 4-segment LED input meters
- Precision Linkwitz-Riley 24dB/octave filters
- Balanced XLR I/O

**SXOVER** two-way adjustable electronic crossover w/Mono Low Switch #SASXOVER ..... **\$49.00**

#SAS3W  
**\$169<sup>00</sup>**

**TC ELECTRONICS****XO24**

Ideally suited for fixed and live install applications, the XO24 is a powerful DSP-based digital speaker management controller that instantly improves the quality of your audio. It incorporates a unique routing engine with "one-click" architecture, configurable as a 2-, 3-, or 4-way speaker management system. Four bands of parametric EQ are available on the inputs and outputs, while limiting, independent delay lines and infinitely-variable crossovers are present on each channel; truly a precision tool for speaker tuning.

- 2 X 4 System Management Controller with intuitive signal-flow based interface
- 4-band parametric EQ on I/O
- Route any input to any output
- Independent speaker alignment and digital limiters on outputs
- Balanced XLR I/O and digital RCA S/PDIF

#TCX024  
**\$799<sup>00</sup>**

**BEHRINGER**

**Europower EP2500**

#BEEP2500  
**\$349<sup>00</sup>**



The EP2500 is an inexpensive 2-channel power amplifier designed to deliver up to 2400 watts of power. Primarily designed for live music applications in small- to mid-sized venues, the EP2500 provides reliable performance with a high-current, low-noise transformer, efficient back-to-front ventilation, independent limiters, overload protection, and high-power resistors.

- 2400-watt capacity bridged mono, 450 watts stereo into 8-ohms
- Designed for installs in small- to mid-sized venues
- Independent protection limiters and selectable 30/50Hz filters
- Ventilation includes air filter with auto-adjusting vari-speed fan
- Balanced XLR and 1/4" inputs, binding posts, and Neutrik Speakon outputs
- 36 lbs

**Europower EP1500** 1400-watt version #BEEP1500.....**\$299.99**

**ASHLY**  
**PE Series**

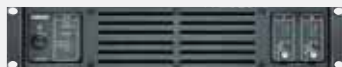

The PE Series offers professional power amplifiers designed to provide superior performance with a high power-to-weight ratio. They can be set up, controlled, and monitored through the built-in Ethernet port using the included Protea software. Ideal for both portable and install applications, each amplifier features extensive control capabilities and delivers onboard processing, including a selectable subsonic filter, clip-limiter, and input-sensitivity selector.

- DSP controllable amplifiers with high power-to-weight ratio
- Optimized for cool operation, modularity, compatibility, and performance
- Optional Protea DSP cards for additional advanced processing
- Capable of DC voltage control of inputs (volume control)
- XLR, TRS, and Euroblock inputs, model-dependent outputs

**PE800** 400 watts/channel @ 4 ohms #ASPE800 ... **\$1010.00**

**PE1200** 600 watts/channel @ 4 ohms #ASPE1200 ..... **\$1195.00**

**PE1800** 900 watts/channel @ 4 ohms #ASPE1800 ..... **\$1425.00**

**PE2400** 1200 watts/channel @ 4 ohms (can drive 70V systems) #ASPE2400..... **\$1720.00**

**PE3000** 1500 watts/channel @ 4 ohms (can drive 70V systems) #ASPE3000..... **\$2105.00**

**PE3800** 1900 watts/channel @ 4 ohms (1700-watts @ 70V) #ASPE3800..... **\$2480.00**

**ALESIS**

**RA-500**

#ALRA500  
**\$379<sup>00</sup>**



The RA-500 is a 500-watt power amplifier that produces 150 watts per channel into 8-ohms. It's designed to match more closely the power needs of almost any passive speaker or studio monitor in project and commercial recording studios, broadcast and post-production control rooms. Convection cooling effectively dissipates heat build-up without any fan noise, eliminating the chance of missing hard-to-hear audio details.

- 500 watts bridged @ 8-ohms, 250 watts/channel @ 4-ohms
- Quiet, cool operation for stable, extended performance
- For use with multiple applications including studios, video-post, and lounges
- Rugged, convection-cooled design in 3U size
- Balanced XLR-1/4" inputs, unbalanced RCA inputs, binding post outputs

**RA300** 300-watt version of above #ALRA300 ..... **\$279.00**

**RA150** 150-watt version of above #ALRA150..... **\$199.00**

**ART**

**SLA2**

#ARSLA2  
**\$299<sup>00</sup>**



The SLA2 is a 200-watt power amplifier designed for pro, project, and home studios use. It's ideal for powering small- to mid-sized studio monitors and is housed in a slim, single-spaced design that's both convection and "smart" fan-cooled (fan speed adjusts with temperature), providing an ample cooling system for warmer environments.

- 200 watts/channel @ 8-ohms
- Clean, simple interface with tamper proof faceplate
- Low-profile design with SmartFan Silent Cooling System
- Ideal for studio and small restaurant/lounge installs
- XLR, Euroblock and 1/4" inputs, binding post outputs

**SLA1** 100-watt version of above #ARSLA1 ..... **\$239.00**

**BEHRINGER**

**A500**

#BEA500  
**\$199<sup>99</sup>**



The A500 is a 500-watt, convection-cooled reference amplifier designed for use in recording studios, post-production

facilities and HiFi lounge applications. Stable, noise-free operation provides accurate audio with a wide dynamic range and little or no distortion. There are multiple connectivity choices that offer maximum flexibility for all levels of users.

- 160 watts/channel @ 8-ohms, 230 watts/channel @ 4-ohms
- Convection-cooled for silent operation and efficient, long-term use
- Precise level meters and clip indicators
- Independent thermal overload protection
- Balanced XLR-1/4" inputs, RCA inputs, binding post and 1/4" TS outputs



**QSC**  
**GX5**

The QSC GX5 is a power amplifier delivering 500-watts at 8 Ohms, designed for smaller-venue sound reinforcement applications. This sturdy workhorse weighs only 26 lbs, and is equipped with XLR and 1/4" inputs. The outputs are on Speakon, 1/4" or Binding Post connectors. The GX5 is equipped with a special crossover switch for subwoofer integration, and proprietary GuardRail overload protection circuitry.



#QSGX5  
**\$399<sup>99</sup>**

- True B-class biasing circuitry with high thermal efficiency
- Class H system with lightning-fast rails for consistent power output
- Full amplifier and load protection
- Detented Gain controls, front panel LED indicators
- Optimized performance with 4 Ohm and 8 Ohm speakers

**GX3** 300-watts@8 Ohms #QSGX3.....**\$299.99**

**CROWN**  
**D-75A**



#CRD75A  
**\$564<sup>50</sup>**

The D-75A is an ideal amplifier for moderate power applications such as recording or broadcast studio near-field monitoring, video post production, or small paging systems. The highly reliable convection-cooled design operates silently and coolly, while still protecting against circuit shorts and spikes. A variety of loads can be used for maximum system flexibility.

- 55 watts/channel @ 4 ohms
- Powerful AB+B class circuitry yields maximum efficiency with minimal distortion
- Ideal for mobile/studio monitoring and low/mid-level paging systems
- Convection-cooled design reduces maintenance costs and environmental effects
- Compact, single-spaced unit with precise detented level controls
- Balanced/unbalanced XLR-1/4" inputs, terminal block bare-wire outputs

**D45** 35-watt version of above #CRD45.....**\$427.95**

**CROWN**  
**CTS8200**

Specially engineered for installed sound applications, the Crown CTS8200 is an 8-channel power amplifier with an output design that offers outstanding reliability and performance. Its lightweight Switch Mode power supply combines efficient power handling, selectable constant voltage or low-impedance operation, and advanced fault/protection circuitry, making the CTS8200 an ideal choice for integrated and distributed audio applications.



#CRCTS8200  
**\$3512<sup>00</sup>**

- 160 watts @ 8 ohms per channel/540 watts @ 8 ohms bridged mono single Ch. pair
- FIT (Fault Isolation Topology) isolates faults within affected channels
- Selectable constant-voltage (70V/100V) or low-impedance (4/8 ohm) operation for each channel pair
- 36.6 lbs

**CTS-8200USP/CN** factory installed 3rd Generation DSP module

#CRCTS8200USP.....**\$5321.00**

**CTS-8200VCA** factory-installed VCA-MC Module for remote level control of each channel

#CRCTS8200VCA.....**\$3750.00**

**ELECTRO-VOICE**

**CP Series**



Built to be both lightweight and powerful, the CP Series uses the best Class-AB (CP1200) and H output design to deliver excellent audio performance, reliability, and operational safety. The amplifiers are reliable, highly efficient, and engineered to limit distortion and clipping during audio bursts capable of damaging most speaker systems.

- Highly efficient, lightweight design
- Class-H technology provides fast voltage switching and less power dissipation
- Complete electrical and thermal overload protection
- 3-speed, front-to-back cooling fans
- Balanced XLR I/O

**CP1200** 400 watts @ 4 ohms

#ELCP1200.....**\$890.00**

**CP1800** 600 watts @ 4 ohms

#ELCP1800.....**\$950.00**

**CP2200** 800 watts @ 4 ohms

#ELCP2200.....**\$1100.00**

**CP3000S** 1100 watts @ 4 ohms (switch-mode power/just 18 lbs.) #ELCP3000S.....**\$1690.00**

**ELECTRO-VOICE**

**Q-Series**



The Q-Series are 2-channel power amplifiers designed for mobile or smaller installations that require clean, reliable performance within a budget. Features include extensive internal circuitry and output protection with high-quality limiters, front-panel LED status, rear-mounted, dB-scaled level controls, and a rugged, zinc-plated steel housing.

- 2-channel, convection-cooled power amplifier
- Built-in limiter with sophisticated input/output comparators
- Normal dual-channel or parallel operation
- Quiet, 3-speed temperature-sensitive fans
- Electronically balanced XLR I/O

**Q44** 450 watts @ 4 ohms #ELQ44.....**\$690.00**

**Q66** 600 watts @ 4 ohms #ELQ66.....**\$790.00**

**CROWN**  
**CDi Series**

The rugged and lightweight Contractor Digital



Intelligence Series amplifiers offer an almost unmatched value in their class. They are capable of driving low-impedance, 70-140V loads, and provide powerful audio DSP features such as preset crossover frequencies, EQ, limiting, compression, delay, and a subharmonic synthesizer. Other professional features include removable Phoenix-style inputs, barrier strip outputs, a universal switch-mode power supply, and of course, an accurate, uncolored sound with extremely low distortion.

- Extremely versatile amplifiers with a low noise, uncolored sound
- Integrated DSP with front-panel LCD display
- Advanced thermal and overload protection circuitry
- Universal switch-mode power supply
- Speaker presets for crossover frequencies, EQ, limiting, compression, delay, and subharmonic synthesizer
- HiQnet software control capability
- Barrier strip connectors for low-Z, 70-140V outputs, Phoenix-style inputs

**CDI1000** 500 watts/channel @ 4 ohms or 70V #CRCDI1000.....**\$1013.00**  
**CDI2000** 800 watts/channel @ 4 ohms or 70V #CRCDI2000.....**\$1373.00**

**CROWN**  
**XLS Series**



The affordable XLS Series amplifiers are designed with musical sound reinforcement in mind. Identical in design except for power and weight, they possess professional features such as balanced XLR inputs, precision detented level controls, extensive protection and diagnostic capabilities, and flow-through ventilation from front to back. They can operate in either Dual or Bridge-Mono mode and provide six front-panel LED's to indicate signal, clip, and fault for each channel.

- Affordable sound reinforcement amplifiers for clubs, bars, and DJ rigs
- Independent precision level controls and front-panel power switch
- LED's provided for signal, clip, and fault indication
- Efficient forced-air fans prevent excessive thermal build-up
- Electronically-balanced XLR inputs; touch-proof binding posts, and Speakon outputs

**XLS202D** 200 watts/channel @ 8 ohms #CRXLS202D.....**\$299.00**  
**XLS402D** 300 watts/channel @ 8 ohms #CRXLS402D .....**\$399.00**  
**XLS602D** 380 watts/channel @ 8 ohms #CRXLS602D.....**\$499.00**  
**XLS802D** 500 watts/channel @ 8 ohms #CRXLS802D .....**\$599.00**

**CROWN**  
**I-T6000**

#CRIT6000  
**\$3359<sup>95</sup>**



The Crown I-Tech series marks a revolutionary breakthrough in amplifier technology. The IT6000 provides engineers with an extensive array of high-resolution 24-bit/96kHz integrated Digital Signal Processors, up to 6000 watts @ 8 ohms bridge-mono of clean uncompromised power, and advanced computer network connectivity. For live sound, touring, and permanent installations the IT6000 is the professional choice.

- 1500 watts @ 8 ohms stereo/5000 watts @ 4 ohms bridge-mono
- System computer controls crossover, delay times, limiter thresholds, EQ, and monitors thermal capacity
- AES/EBU digital inputs
- 24-bit/96kHz Cirrus Logic A/D-D/A converters
- RJ-45 TCP/IQ network connectivity for complete DSP control
- 28 lbs.

**I-T8000** 2100 watts @ 8 ohms stereo/7000 watts @ 4 ohms bridge-mono #CRIT8000 .....**\$7762.00**  
**I-T4000** 1250 watts @ 8 ohms stereo/3600 watts @ 4 ohms bridge-mono #CRIT4000 .....**\$5050.00**

**QSC**  
**PL Series**

The QSC PL Series is a group of lightweight power amplifiers with high power output capacities, designed for



use in live touring or fixed-installation audio applications. Their high-efficiency Class H output circuitry reduces AC consumption and necessity for cooling, and the PowerLight switchmode power supply guarantees stable output with improved audio performance.

- 2-channel high-power touring and installation amp
- Dataport installed for digital remote control/processing
- User-defeatable clip limiting and selectable LF filters per channel
- Comprehensive level, mode, and signal indicators
- XLR and 3-pin detachable terminal block inputs
- Speakon and 5-way binding post outputs

**PL325** 500-watts@8 Ohms #QSPL325.....**\$1253.00**  
**PL340** 800-watts@8 Ohms #QSPL340 .....**\$1633.00**  
**PL380** 1500-watts@8 Ohms #QSPL380.....**\$2375.00**

## CROWN XTi Series



Built for professional portable PA applications, the XTi Series amplifiers offer advanced DSP and high power output capabilities from their rugged, lightweight designs. All units feature an LCD screen with DSP presets for crossover points, EQ, limiting, delay, and a subharmonic synthesizer. Performance is monitored and aided via useful function indicators, a switch-mode power supply, proportional speed, fan-assisted cooling, and internal circuit protection.

- Designed for high-quality professional mobile PA applications
- Extremely accurate, uncolored sound with ultra-low distortion
- Integrated DSP with front panel LCD screen
- Advanced circuit protection guards against overheating, overloads, shorts, and more
- XLR inputs, Speakon and binding post outputs
- Switch-mode universal power supply
- Speaker presets for crossover frequencies, EQ, limiting, and delay

**XTI4000** 1200 watts/channel @ 4 ohms (shown) #CRXTI4000...**\$999.00**  
**XTI2000** 800 watts/channel @ 4 ohms #CRXTI2000.....**\$699.00**  
**XTI1000** 500 watts/channel @ 4 ohms #CRXTI1000.....**\$499.00**

## ASHLY TRA-Series



The TRA Series are convection-cooled amplifiers that combine great sound, efficient performance, simultaneous low impedance, and transformer-coupled 70/100V output. Every TRA amplifier utilizes a switch-mode power supply, Class-D circuitry and provides a compact, lightweight powering solution needing little or no maintenance. Its rear panel features Euroblock inputs, level controls, screw terminal outputs, and selectable switches for input sensitivity, high-pass filter, and normal or bridged mode operation.

- Highly efficient, precision install amplification
- Simultaneous low impedance and transformer-coupled 70/100V output
- Ultra-quiet, convection-cooled amplifiers with switchable power supplies
- 6-segment signal level LED's for each channel
- Extensive protection circuitry
- Euroblock inputs/screw terminal outputs

**TRA2075** 75 watts/channel @ 4 ohms stereo, 70V and 100V  
 #ASTRA2075.....**\$630.00**  
**TRA2150** 150 watts/channel @ 4 ohms stereo, 70V and 100V  
 #ASTRA2150.....**\$715.00**

## EAW CAZ800

#EACAZ800  
**\$299<sup>00</sup>**

Part of the CAZ Amplifier Series, the CAZ800 is a two-channel, 800-watt power amplifier designed for permanent install applications, including houses of worship, commercial offices, hotel ballrooms and paging systems. It provides two variable-speed fans for cool operation, switchable low-cut filters for tighter bass response, and switchable limiters with LED's for reliable protection from output spikes and hard clipping, ultimately increasing the life span of the amplifier.



- 250 watts/channel @ 8 ohms, 300 watts/channel @ 4 ohms, 800 watts bridged into 4 ohms
- Designed for commercial install use
- Low-noise/low-distortion design
- Switchable component protection limiters on both channels
- Balanced/unbalanced 1/4" TRS and XLR inputs
- Screw terminal outputs

**CAZ1400** 1400 watt version of above, 450 watts/channel @ 4 ohms  
 #EACAZ1400.....**\$529.00**  
**CAZ2500** 2500 watt version of above, 750 watts/channel @ 4 ohms  
 #EACAZ2500.....**\$495.00**

## MACKIE M-2000

#MAM2000  
**\$749<sup>99</sup>**



The M-2000 is a high-efficiency stereo power amplifier that delivers 2000 watts of clean power from a standard 120/240V outlet. Its Adaptive Slewing technology and Fast Recovery circuitry gives it super-low distortion specs and incredibly fast transient response. It is equipped with the most advanced protection circuitry available, including thermal protection, output DC offset protection, input slew protection, extensive output stage protection.

- 325 watts per channel @ 8 ohms stereo, 2000 watts bridged @ 4 ohms
- XLR/TRS input combo connectors, plus barrier strip
- (3) Speak-on locking output connectors
- Baker Clamp-based Fast Recovery circuitry
- Built-in Limiter
- 2U, 14-gauge steel chassis

**M3000** 475 watts per channel @ 8 ohms Stereo, 3000 watts  
 bridged @ 4 ohms #MAM3000.....**\$899.99**  
**M4000** 650 watts per channel @ 8 ohms Stereo, 4000 watts  
 bridged @ 4 ohms #MAM4000.....**\$999.99**



**MACKIE**  
**FR Series**

The Mackie FR Series is a group of rugged, low-cost power amplifiers with high power output capacities, designed to fit the budgets of schools and smaller houses of worship as an audio installation solution. These fan-cooled amps offer quiet operation with extremely low noise and distortion, a no-nonsense user interface and an elegantly simple front panel.

- 2-channel low-noise installation amplifier series
- Durable housing with front panel handles
- Stereo, dual mono, and bridged mono operating modes
- Overload, overheating, and short-out protection circuitry
- Power, signal and overload LED indicators
- XLR and 1/4" inputs, Speakon and binding post outputs



- FR-800** 300-watts@4 Ohms #MAFR800 .....**\$299.99**
- FR-1400** 450-watts@4Ohms #MAFR1400.....**\$399.99**
- FR-2500** 750-watts@4Ohms #MAFR2500 .....**\$499.99**



**QSC**  
**RMX 4050HD**

#QSRMX4050HD  
**\$1399<sup>00</sup>**

Well suited for both touring and fixed install applications, the QSC RMX4050HD is a heavy-duty, high-performance amplifier that provides up to 4000 watts of power for today's demanding professional sound engineer.

- 850 watts @ 8 ohms stereo/4000 watts @ 4 ohms bridged mono
  - 5-way binding posts and Neutrik Speakon outputs
  - Selectable low-frequency filters
  - Internal overload protection • 68 lbs
- RMX 2450** 500 watts @ 8 ohms stereo/2400 watts @ 4 ohms bridge-mono #QSRMX2450..... **\$629.00**
  - RMX 1850HD** 360 watts @ 8 ohms stereo/1800 watts @ 4 ohms bridge-mono #QSRMX1850HD..... **\$529.00**
  - RMX 1450** 280 watts @ 8 ohms stereo/1400 watts @ 4 ohms bridge-mono #QSRMX1450 ..... **\$429.00**
  - RMX 850** 200 watts @ 8 ohms stereo/830 watts @ 4 ohms bridge-mono #QSRMX850..... **\$319.00**

**QSC**  
**PLX 3602**

#QSPLX3602  
**\$1199<sup>99</sup>**

Delivering a full, detailed response, the QSC PLX 3602 is an affordable, heavy-duty amplifier that delivers up to 3600 watts of low-noise output power. QSC's PowerWave technology efficiently manages its power handling capabilities while providing reliable, high-level audio performance, making it ideal for touring rigs and PA installations.

- 800 watts per channel @ 8 ohms stereo/3600 watts @ 4-ohms bridge-mono
- Balanced 1/4" TRS & XLR inputs
- Neutrik Speakon and 5-way binding post outputs
- 21-position, front-panel gain controls
- Advanced thermal management system for efficient heat dissipation & cooling
- 21 lbs

- PLX-1802** 330 watts per channel @ 8 ohms stereo #QSPLX1802..... **\$799.99**
- PLX-2502** 450 watts per channel @ 8 ohms stereo #QSPLX2502 ..... **\$899.99**
- PLX-3102** 600 watts per channel @ 8 ohms stereo #QSPLX3102 ..... **\$999.99**



**ROLLS**  
**RA200**

#RORA200  
**\$309<sup>95</sup>**

The RA-200 is a stereo power amplifier that delivers 70 watts per channel into 8-ohms. Its fanless, convection-cooled design makes it ideal for studio monitoring and small lounge/sound reinforcement applications. It features a bridging switch, one-second power-up delay and a MOSFET output stage that is thermal and fault protected, preventing momentary shorts and overloads from affecting audio output.

- 70-watt stereo amplifier, 100 watts @ 4 ohms
- MOSFET drivers in a voltage and current gain circuit
- Front-panel input controls with LED power output meters
- Overload and fault-protected outputs
- Universal power supply for worldwide use
- 1/4" and RCA inputs, 1/4" or dual-banana outputs

- RA235** convection-cooled with 35 watts/channel, ideal for low-level monitoring #RORA235..... **\$187.50**

**SAMSON**  
**Servo 600**

#SASA600  
**\$299<sup>00</sup>**

The Servo 600 is a 600-watt power amplifier designed to perform equally well in the studio or in small PA applications. Components are protected via a 4-stage power protection, and large 10-segment, tri-colored LED meters allow users to view ideal output levels clearly before clipping.



- 300 watts/channel @ 4 ohms, 600 watts bridged mono @ 8 ohms
- Ideal for use with larger studio monitors or restaurant/lounge PA systems
- 4-stage power protection • 1/4" and RCA inputs, 5-way binding posts and 1/4" outputs

<b>Servo300</b> 300-watt version of above #SASA300.....	<b>\$219.00</b>
<b>Servo200</b> 200-watt version of above #SASA200.....	<b>\$189.00</b>
<b>Servo120a</b> 120-watt, single-space, fanless version of above #SASA120A.....	<b>\$179.00</b>



**SAMSON**  
**SX-2800**

#SASX2800  
**\$549<sup>00</sup>**

The SX-2800 provides up to 2800 watts of clean, crisp audio with an impressive dynamic range and low-distortion output, ideal for mid-sized and larger venues. Its unique stable bipolar circuit design serves to minimize heat overload by preventing the amplifier from applying power unnecessarily, increasing overall power efficiency.

- |   |                 |  |   |
|---|-----------------|--|---|
| <b>SX3200</b> 750 watts @ 8 ohms #SASX3200..... | <b>\$649.00</b> | • 700 watts/channel @ 8 ohms, 2800 watts bridged mono @ 4 ohms | • High-current power supply with user-resettable circuit breaker  |
| <b>SX2400</b> 550 watts @ 8 ohms #SASX2400..... | <b>\$499.00</b> | • Protection relay circuitry and dual forced-air cooling fans  | • Combo XLR-1/4" inputs and 5-way binding post or Speakon outputs |
| <b>SX1800</b> 400 watts @ 8 ohms #SASX1800..... | <b>\$389.00</b> |  |   |
| <b>SX1200</b> 300 watts @ 8 ohms #SASX1200..... | <b>\$299.00</b> |  |   |

**TAPCO**  
**Juice Series J-2500**

#TAJ2500  
**\$399<sup>99</sup>**

Designed to meet the rigorous performance standards of mid-to-large sound reinforcement applications, the high-powered J-2500 power amp provides 2500 watts of clean, reliable power. It features a Mode Select switch for choosing between mono/stereo and bridged mono operation, a 30Hz subsonic filter, stringent circuit protection, and multiple connectivity choices for maximum convenience.



- 750 watts/side @ 4 ohms, 575 watts @ 8 ohms
- Switchable limiters on both channels
- Signal present and overload LED's
- Dual variable-speed fans with back-to-front airflow
- XLR and 1/4" inputs, Speakon, and binding post outputs

<b>J1400</b> 1400-watt version of above #TAJ1400.....	<b>\$299.99</b>
<b>J800</b> 800-watt version of above #TAJ800.....	<b>\$229.99</b>



**YAMAHA**  
**P7000S**

#YAP7000S  
**\$699<sup>00</sup>**

Ideal for traveling ministries, club musicians, and mobile sound companies, the Yamaha P7000S is an affordable, lightweight amplifier that delivers up to 3200-watts of power. The P Series amplifiers are integratable with Yamaha's Club Series speakers, and are equally well suited for use with any existing PA sound system.

- 750 watts per channel @ 8 ohms stereo/3200 watts @ 4 ohms bridged mono
- Yamaha Speaker Processing switch
- Filter switch (Sub Woofer/ Low Cut/Off)
- S/N ratio 104dB
- Balanced XLR and TRS 1/4" inputs
- 5-way binding posts, Neutrik Speakon and 1/4" TRS outputs
- Variable Speed cooling fans
- 26.5 lbs

<b>P5000S</b> 525 watts per channel @ 8 ohms stereo #YAP5000S...	<b>\$599.00</b>
<b>P3500S</b> 390 watts per channel @ 8 ohms stereo #YAP3500S...	<b>\$499.00</b>
<b>P2500S</b> 275 watts per channel @ 8 ohms stereo #YAP2500S...	<b>\$399.00</b>

**TOA ELECTRONICS**

**ER3215**

The ER3215 is a powerful and light-weight handheld megaphone with a detachable microphone and strap, enabling over-the-shoulder transport. Both the main body and the handheld microphone feature volume control and an on/off switch. The powerful amplifier and horn allow the user to project his voice up to 1300 feet through noisy environments.

- 23 watts of max power
- Antibacterial treatment
- Powered using (6) "C" batteries
- 9-hour operation time
- 5-year warranty
- 2.5 lbs



#TOER3215  
**\$78<sup>00</sup>**

**TOA ELECTRONICS**

**ER520S**

The ER520S from TOA Electronics is a compact and light-weight handheld megaphone. Its durable red resin construction and 800-foot voice projection make it useful in situations where you need your presence felt both audibly and visually. A powerful siren is included that can project over 1000 feet. A neodymium microphone improves voice clarity.

- 10 watts max output
- Antibacterial treatment for handle and mouthpiece
- Powered using (8) AA batteries
- 8-hour operation time
- 5-year warranty • 23 oz.



#TOER520S  
**\$55<sup>50</sup>**

**CALIFONE**

**PA-15 Megaphone**

The PA-15 is a durable 15-watt megaphone designed for crowd communication in both indoor and outdoor environments. It operates on 6 rechargeable Ni-Cad D batteries and effectively covers a range of 1000 feet. Ideal for training drills, police crowd control, and on-set direction.

- 15 watts of power
- Up to 1000 feet of coverage
- Rugged ABS construction
- Powered via (6) rechargeable Ni-Cad D batteries
- Convenient carrying strap included
- Special announcement siren



#CAPA15  
**\$49<sup>95</sup>**

**PA-8** 8-watt version of above capable of reaching 500 feet #CAPA8..... **\$39.95**

**ANCHOR AUDIO**

**Little Big Horn Megaphone**



The LBH-30 is an easy-to-use, easy-to-store megaphone built from a high-impact ABS resin construction. It weighs just 4 pounds with batteries installed, features efficient circuitry for extended battery life, and projects loud and clear up to a quarter mile.

- 30 watts output
- Battery-powered using (8) C-size 1.5V alkaline
- 10-14 hours operation time
- Special emergency siren
- Re-entrant horn speaker type
- 117dB max SPL • 3.3 lbs

#ANLBH30  
**\$120<sup>00</sup>**

**CALIFONE**

**PA-285AV**

Designed as an "in-the-field" personal monitoring solution with portable audio recording devices, the PA-285AV is also ideal for solving miniature PA requirements for tours and guides. It's inexpensive, battery-powered, and supplies a belt-clip, headset microphone, and 5 watts of power.

- 5-watt, 3.5" woofer
- On/Off, volume and tone controls
- Light yet durable, weighing only 19 oz
- Power on and charging LED indicators
- Recessed desktop tripod mount located on bottom of unit
- 19 oz.



#CAPA285AV  
**\$82<sup>95</sup>**

**PA-282AV** 2-watt version of the PA-285AV above #CAPA282AV..... **\$59.95**



**CALIFONE****PA Pro PA 10A**

The PA-Pro PA10A is an ultra-portable wireless PA system ideal for schools, meetings, tour groups, and crowd-control applications. This versatile system is powerful enough to be used for up to 150 people and is equipped with a built-in rechargeable battery, a wireless mic/belt pack transmitter and separate tone & volume controls.

- For crowds of 150
- Power output: 20 milliwatts
- Lightweight transmitter and belt-pack transmitter
- Internal storage space for transmitter, charger, and mic
- Built-in carrying handle
- Telescoping antenna
- 6-hour battery life (8-hour recharge time)
- Rugged ABS plastic casing
- 5 lbs (without batteries)

#CAPA10A  
**\$174.95****PA 10B** 210.250 MHz frequency version #CAPA10B.....**\$174.95****OKLAHOMA SOUND****PAW-90x**

The PAW-90x is a compact personal PA/wireless microphone system designed for business meetings, conferences, and classroom applications. This extremely portable system includes a rechargeable receiving station (average battery life 8 hours per charge), a wireless transmitter with a lavalier microphone, and a compact carrying case.

- Rechargeable personal PA system
- Output power: 7 watts
- Operating distance from receiver is 200'
- Includes Lead Acid rechargeable battery
- Volume and Tone controls
- Transmitter includes belt clip or fits in pocket
- Optional Handheld & Headset Microphones
- 4.5 lbs

#OKPAW90X  
**\$214.95****AMPLIVOX SOUND SYSTEMS****S610A**

The S610A, known as the Half-Mile Hailer Megaphone, is a D-cell-powered portable P.A. system packing a 50-watt output, a Multimedia amplifier with separate tone and volume controls, and a dynamic microphone with a coiled cable. The amp's Aux input allows for integrating audio playback devices and even a laptop computer for presentation purposes, and the AmpliVox people guarantee a 5000-person coverage or up to half-mile range.

- 50-watt portable sound system with Megaphone and coiled-cabled microphone
- Weather-proof casing
- (3) microphone inputs for dynamic, condenser, and wireless mics
- (2) speaker outputs
- (10) D-cell battery operation with 200-hr. battery life

#AMS610A  
**\$343.95****CALIFONE****PA-300 Plus**

The PA-300 Plus is a portable, self-contained, 2-way, 30-watt amplified PA system designed as an inexpensive presentation, lecture, and classroom audio solution. It features both balanced XLR and unbalanced 1/4" inputs with a line level in and out for attaching CD players, tape decks, and other portable devices.

#CAPA300P  
**\$159.95**

- 30-watt powered speaker with 5.25" woofer and 0.5" tweeter
- Portable, rugged design
- Bass and Treble tone controls
- 1/4" unbalanced phone out
- AC power supply
- 60Hz-20kHz frequency response
- 10 lbs

**PA-300PQ kit** comprised of PA300 speaker, PADM-515 mic, 15-ft. mic cable, MB-300 mounting bracket, and TP-30 speaker stand #CAPA300PQ.....**\$295.95**

**ANCHOR AUDIO****PB-25**

The PB-25 Minivox PA system is a portable, battery-powered sound system weighing in at only 5.5 lbs. It runs for 24 hours on nine C cell alkaline batteries, and is equipped with a handheld microphone with 6" coiled cable, a 1/4" Lo-Z mic input and a 3.5mm line level input for CD and tape players.

#ANPB25  
**\$260.00**

- Ideal solution for tour guide and presentation use
- Lightweight and compact
- Lo-Z 1/4" Mic input
- For crowds of 150
- 15-watt amplifier w/ 5" high-efficiency speaker
- VHS Wireless option available
- Frequency response: 100 Hz- 12 kHz
- Optional rechargeable battery kit
- 5.5 lbs

**CC-25** optional nylon carrying bag #ANCC25.. **\$37.00**

**ANCHOR AUDIO**

**Mega-6000**

#ANM6000  
**\$546<sup>00</sup>**

The Mega-6000 MegaVox Pro is a compact, portable voice amplification system designed for presenters addressing crowds of 3000 or more. It is equipped with a 22-watt amplifier and a high-efficiency re-entrant horn driver. The unit is supplied with a dynamic handheld microphone, a signal alert button and a built-in rechargeable battery (with a 10-hour battery life).



- Ideal for auctioneers, coaching, and law enforcement
- (2) 1/4" mic inputs, (1) 1/4" line input & output
- Dynamic handheld microphone with coiled cable
- True AC/DC-120/220 power supply
- Handheld or stand mountable
- Rugged, durable injection-molded case
- 15 lbs

Configurations including wireless receivers are available for this system.

**AZDEN**

**APS25B**

#AZAPS25B  
**\$199<sup>95</sup>**

The versatile APS25B from Azden is a portable powered speaker system with 20-watts of power. It provides the ability to operate from a rechargeable battery or AC power. You can use a wired microphone or add one or two wireless modules. With a line level input for background music and output for an additional speaker, the APS25B is a unique solution for presentations, meetings, and events.

- 20 watts from its 5.25" woofer and 1" tweeter
- For crowds up to 200 people
- Optional VHF, UHF, and Infrared wireless modules
- 1/4" mic input, line level RCA I/O
- Wall-mount bracket included
- 11.35 lbs



- APS-25** same as above without battery power capability #AZAPS25 ..... **\$159.95**
- APS-IR** single channel infrared plug-in module #AZAPSIR ..... **\$199.95**
- APS-VR** single channel VHF plug-in module #AZAPSVR..... **\$109.95**
- APS-UR** single channel UHF plug-in module #AZAPSUR ..... **\$199.95**

**ANCHOR AUDIO**

**AN-130**

#ANAN130BK  
**\$184<sup>00</sup>**



At just 8.5 pounds, the AN-130 is the ideal PA solution for corporate presentations and lectures. Designed to cover up to 100 people, it features 30 watts of power, a magnetically-shielded 4.5" carbon fiber speaker, and a rugged injection-molded case built to handle all the wear and tear portable PA's receive.

- 30 watts of power from a 4.5" woofer and 1" dome tweeter • 1/4" low-Z mic and line inputs/(2) RCA line level inputs • 101dB max
- Front panel bass and treble tone controls
- 65Hz-18kHz frequency response • 8.5 lbs

- AN-130W** same as above in white #ANAN130. **\$184.00**
- AN-130U1** same as above with built in UHF wireless system and remote control #ANAN130U1 ..... **\$339.00**

**ANCHOR AUDIO**

**Explorer Pro EXP-6000**

#ANEXP6000  
**\$795<sup>00</sup>**



Designed for crowds of 800+ people, the EXP-6000 is a portable sound system featuring a high-efficiency amplifier and full-range speaker. Ideal for schools, corporate trainers, and houses of worship, the EXP-6000 is equipped with two universal mic inputs, a built-in rechargeable battery and a "voice-over" music feature.

- 6.5" woofer & high-output horn tweeter
- For crowds of 800+ • 60 watts AC mode/30 watts DC mode • (2) XLR mic inputs, 1/4" & RCA I/O • Rapid-charger circuitry (60min. charge time)
- Durable, injection-molded case • True Universal AC/DC-120/220V power supply • 23 lbs

- EXP-6000U1** same as above with a single UHF receiver #ANEXP6000U1 ..... **\$1057.00**
- EXP-6000U2** same as above with two UHF receivers #ANEXP6000U2 ..... **\$1319.00**
- EXP-6001** passive companion speaker for the Explorer Pro system #ANEXP6001... **\$75.00**
- SC-50** 50-foot speaker cable for the EXP-6001 #ANSC50..... **\$33.00**
- SS-550** heavy duty speaker stand for EXP-6000 and EXP-6001 #ANSS550..... **\$123.00**
- WH-6000** 16-channel handheld wireless UHF microphone #ANWH6000..... **\$319.00**
- WB-6000** 16-channel UHF body-pack transmitter (mic not included) #ANWB6000 ... **\$240.00**
- LM-60** clip-on lapel microphone for WB-6000 #ANLM60 ..... **\$79.00**
- HBM-60** headset microphone for WB-6000 #ANHBM60 ..... **\$79.00**
- HC-1620** travel/storage hard-shell case with rollers #ANHC1620..... **\$257.00**
- NL-EXP** fitted durable nylon storage cover #ANNLEXP..... **\$37.00**

**GALAXY AUDIO****PA 5X140**

The PA 5X140 is a feature-laden powered personal monitor capable of delivering 100 watts of continuous audio from its 5" full-range speaker. Unique level-sensing balanced 1/4" and XLR inputs each have their own volume controls and are routed through the built-in compressor/limiter and 3-band EQ, allowing a more controlled dynamic sound with minimal distortion. Ideal for on-stage monitoring of vocals, keyboards, and more.

- 100 watts of power from fluid-cooled Neodymium 5" full-range speaker
- Compressor/limiter and 3-band EQ
- H-Class amplifier with low- and high-voltage output for increased efficiency and cooler operation
- Both 1/4" and XLR inputs sense mic or line level (SmartALIC circuitry)
- Speaker and RCA outputs
- Short circuit limiting and thermal protection
- 115Hz-18kHz frequency response



#GAPA5X140  
**\$299<sup>99</sup>**

**ANCHOR****AN-1000X**

Designed for classroom, presentation, and even studio monitoring applications, the AN-1000X is a 2-way, 50-watt portable PA speaker with a powerful clean sound, magnetic shielding, and full complement of connectivity, making it ideal for both consumer and professional audio/video needs.

- 50-watt, 4.5" woofer and dome tweeter capable of reaching up to 400 people
- Easily accessible front panel bass, treble, and volume controls
- Magnetically shielded for use near projectors and video monitors
- XLR, 1/4" and RCA inputs with 1/4" speaker out
- 65Hz-20kHz frequency response
- 9.5 lbs

#ANAN1000X  
**\$382<sup>00</sup>**

**REMOTE AUDIO****Speak Easy v2**

The Speak Easy v2 is a portable direct-communication solution designed for directors and actors or producers and musicians. Essentially a lightweight (4 lbs) battery-powered monitor with a front panel volume control, the speaker sports a pair of balanced XLR dynamic mic and mic-level inputs and a line-level RCA input on the rear will accept wireless feeds and other unbalanced signals.

- 9V or remote battery-powered portable monitor speaker
- Front panel volume control and power LED
- Loudness and frequency response optimized for application
- Push-to-talk button
- XLR input #1 for balanced +4dB signals
- XLR input #2 for mic level signals
- RCA input for unbalanced -10dB signals



#RESEV2  
**\$239<sup>00</sup>**

**ROLAND****CM-30**

The CM-30 is a self-contained 3-channel monitor with 30 watts of power. Featuring a single XLR microphone input and two stereo inputs, it's ideal for musicians who need to monitor themselves on stage, as well as amplify a voice for presentations with background music. Two of these units can be linked for additional power and I/O.



#ROCM30  
**\$175<sup>00</sup>**

- 30 watts of power from its 6.5" 2-way coaxial speaker
- Front panel EQ control
- Headphone jack with independent volume knob
- Stereo RCA and 1/8" mini-plug auxiliary inputs
- Handles five simultaneous inputs
- 12.6 lbs

**OKLAHOMA SOUND CORP****PRA-6000**

#OKPRA6000  
**\$399<sup>95</sup>**

The PRA-6000 is a 50-watt, all-in-one, battery-powered PA system with an integrated CD player and tape recorder. Built into a rugged rolling case with a telescoping handle, it offers three microphone inputs and EQ controls. The cassette deck is capable of recording the performance/presentation as it happens.

- 3-channel, 50-watt system
- 8" woofer, 4" tweeter
- Built-in rechargeable battery
- Reach audiences up to 500 people
- Wired handheld microphone included
- 35 lbs

**PRA-7000** 100-watt, 10" woofer version with included handheld wireless system #OKPRA7000 ..... **\$779.95**

**PRA-TRD** Tripod stand to mount 6000/7000 systems at ear level #OKPRATRD ..... **\$64.95**

**PRA-6** Wireless tie-clip lavalier microphone with beltpack transmitter #OKPRA6 ..... **\$89.95**

**PRA-7** Wireless headset microphone with beltpack transmitter #OKPRA7 ..... **\$114.95**



**CALIFONE**

**Power Pro PA-916**

The Power Pro PA-916 is a complete self-contained sound system equipped with two built-in wireless mic receivers, a fully-programmable CD player and a variable-speed cassette recorder/player. Designed to provide sound coverage for crowds up to 1000 people, the PA-916 is an ideal for schools, government facilities, presentations/conferences, athletic events, house of worship, and A/V applications.



#CAPA916  
**\$1069<sup>95</sup>**

- Easy-to-use, portable sound reinforcement solution
- Total power: 90 watts • 10" woofer & horn tweeter
- (2) XLR/1/4" mic inputs with volume controls, (2) XLR outputs • (2) 16-channel UHF wireless mic receivers
- Built-in CD player and cassette player/recorder
- 100-240VAC universal power supply and 12V lead acid battery • 52 lbs

*Configurations including wireless transmitters, companion speakers and stands are available for this system.*

- PA-916B** basic package #CAPA916B .....**\$1234.95**
- PA-916D** deluxe package #CAPA916D .....**\$1754.95**
- PA-916A** wireless package #CAPA916A ...**\$1936.95**

**ANCHOR AUDIO**

**Liberty LIB-6000H**

The LIB-6000H is a portable 50-watt sound system designed to provide sound coverage for crowds up to 1000 people. It is equipped with two universal XLR Mic inputs, a built-in rechargeable battery and built-in limiter protection circuitry lowers distortion and increases intelligibility.

- 8" woofer and titanium dome compression driver
- For crowds of 1000+ • (2) XLR Mic inputs
- 1/4" speaker output, 1/4" line output, 1/4" line input
- Durable, injection-molded case • Speech Projection switch
- Bass and Treble controls • True Universal AC/DC-120/220V power supply • 44 lbs



#ANLIB6000H  
**\$1245<sup>00</sup>**

- LIB-6000HU1** same as above with a single UHF receiver #ANLIB6000HU1.....**\$1472.00**
- LIB-6000HU2** same as above with two UHF receivers #ANLIB6000HU2..... **\$1717.00**
- LIB-6000HCU** same as above with a CD player and a single UHF receiver #ANLIB6000HCU ..... **\$1703.00**
- LIB-6000HCU2** same as above with a CD player and two UHF receivers #ANLIB6000HCU2 ..... **\$1834.00**
- WH-6000** 16-channel handheld wireless UHF microphone #ANWH6000.....**\$319.00**
- WB-6000** 16-channel UHF body-pack transmitter (mic not included) #ANWB6000 ...**\$240.00**
- LM-60** clip-on lapel microphone for WB-6000 #ANLM60 ..... **\$79.00**
- HBM-60** headset microphone for WB-6000 #ANHBM60 ..... **\$79.00**
- LIB-6001** passive companion speaker for the Liberty system #ANLIB6001 .....**\$326.00**
- SC-50** 50-ft. speaker cable for the EXP-6001 #ANSC50 ..... **\$33.00**
- SS-550** heavy-duty speaker stand for LIB-6000 and LIB-6001 #ANSS550..... **\$129.00**
- NL-6000** fitted durable nylon storage cover for the Liberty system #ANNL6000... **\$41.00**
- HC-1650LX** travel/storage hard-shell case with rollers #ANHC1650LX..... **\$257.00**

**FENDER**

**Passport PD-150**



#FEPPD150  
**\$499<sup>99</sup>**

The PD-150 is a completely self-contained portable 150-watt PA system designed to provide audio for presentations, school programs, lectures, or any application requiring sound for up to 300 people. Its stereo powered amplifier and 4-channel mixer is protected from physical damage and the elements by a black luggage-style molded case, all under 28 lbs in weight.

- 150 watts for up to 300 people • Simple setup and operation with unique one-touch controls and EQ contour
- 5.5" woofers and dual arrayed 2.75" tweeters per cabinet
- 4-input mixer (3) mic/line (1) mono/stereo
- P-51 microphone with clip, cables, and carrying pouch
- Durable black luggage-style carrying case
- Operates on AC or Passport DC power accessories

**ANCHOR AUDIO**

**Beacon BEA-6000**

The Beacon sound system is a lightweight portable speaker array with eight 4.5" mid-range speakers and three 8" woofers. It provides 120° of coverage at distances of up to 500', and is equipped with (2) universal Mic inputs and a "voice-over" music ducking function. The Beacon's durable case features both wheels and a retractable handle.

- Ideal solution for adding voice and music to presentations
- For crowds of 5000+
- (8) 4.5" mid-range speakers, (3) 8" woofers
- (2) XLR mic inputs, 1/4" line I/O, stereo RCA I/O
- Deploys to a height of 6 feet
- Built-in voice-over music ducking
- True AC/DC-120/220V power supply



#ANBEA6000  
**\$1711<sup>00</sup>**

- BEA-6000C** same as above with a built-in CD player #ANBEA6000C.....**\$1879.00**
- BEA-6000U1** same as above with a single UHF receiver #ANBEA6000U1..... **\$1879.00**
- BEA-6000U2** same as above with two UHF receivers #ANBEA6000U2..... **\$2047.00**
- BEA-6000CU1** same as above with single UHF receiver and CD player #ANBEA6000CU1..... **\$2047.00**
- BEA-6000CU2** same as above with two UHF receivers and CD player #ANBEA6000CU2..... **\$2215.00**

**ALESIS****TransActive Mobile**

The TransActive Mobile is a portable 15-watt P.A. system equipped with a universal iPod docking station designed for party and event use or one-person musical gigs. The ruggedly-constructed all-aluminum housing features built-in retractable handles and a pair of wheels to facilitate a busy event schedule. The two-way speaker setup provides enhanced bass response and 150' of coverage.

- Portable 15-watt P.A. system with universal iPod docking station
- 2-way speaker with enhanced bass response, recessed stand adapter
- XLR/TRS combo mic in, 1/4" TS instrument in, Stereo RCA Aux inputs
- iPod dock connector, iPod charge selector
- (3) input channel gain knobs, Master Volume knob
- Dynamic microphone and cable supplied
- Built-in rechargeable battery with 6-hr. life



#ALTM  
**\$299<sup>00</sup>**

**PEAVEY****Messenger**

The Messenger from Peavey is fully functional 100-watt compact PA system that folds-up into a carry-on size case. Designed for ease of use and rapid set-up, the lid of the unit acts as a lectern during presentations. All of the necessary cables and a handheld microphone are included and have a dedicated compartment for storage within the system.

- 100 watts total power from its 4" woofers and 1" tweeters
- 5-band EQ with Feedback Locating System
- Split-Track mix functionality for Karaoke
- (2) XLR Mic inputs, (1) 1/4" mic/line input, (1) RCA stereo input
- Cables and handheld microphone included
- 24.8 lbs.

#PEMESSENGER  
**\$399<sup>95</sup>**

**MACKIE****SRM150**

The SRM150 is an extremely portable active loudspeaker system that features a built-in 3-channel mixer and delivers 150 watts of high-output, Class-D power. Its compact size and high power punch make it a perfect choice for an amazing number of possible applications. Not only is it an excellent loudspeaker system for compact PA applications, but it also offers unparalleled performance as a personal monitor. In addition to stand mounting, this solidly-made unit was designed to provide the proper monitoring angle when used in traditional floor wedge and tabletop placement. The rear panel Thru jack provides connectivity for an extra powered monitor, or for sending a mic level output to the front of house system.

- Portable high-output active loudspeaker system
- 3-channel mixer with 3-band active EQ
- Two high-headroom Mackie Mic/line preamps with 48V phantom power
- Dedicated stereo channel for keyboards, CD, MP3, iPods, etc.
- Complete system protection with built-in limiter



#MASRM150  
**\$299<sup>99</sup>**

**FENDER****Passport P-80**

The Passport P-80 is a lightweight portable sound system suitable for use in lecture or club date applications, serving crowds of up to 150 persons. The system sports a convenient luggage-style foldaway design for simplified transportation and setup, and features a built-in mixer with 9 inputs and a digital reverb. The AC power supply supports multiple voltages for international use.

- Portable self-powered P.A. system with luggage-style folding design
- 80 watts power, 4-channel mixer
- (4) 6.5" speakers, 2 per cabinet
- (2) XLR microphone inputs
- Global and individual channel EQ's
- Dynamic handheld microphone with 18' cable, (2) 20' speaker cables

#FEPP80  
**\$399<sup>99</sup>**

**FENDER****Passport Deluxe PD-500**

Designed for musicians on the go, the PD-500 is a portable sound system that features an 8-channel mixer, powerful 500-watt amplifier, patented Feedback Killer, digital effects, and 48V phantom power. Each speaker cabinet contains two ultra-efficient 8" neodymium speakers, a titanium compression driver, and horn that provide increased performance with decreased weight.

- Portable 8-channel PA system with 500-watt Class D amplifier and dual 8" woofers
- Designed for musical performance and presentations for audiences ranging from 500-800 people
- Docking Connector for Passport Wireless receiver
- 6/2 mic/line channels with level, FX send, Monitor, Pan, EQ and 20dB pad
- (2) P-51 Mic Kits are included containing a dynamic mic and cable
- 53 lbs

#FEPPD500  
**\$1399<sup>00</sup>**

**SOUNDCRAFT**  
**GIGRAC 600**

#S0GR600  
**\$399<sup>00</sup>**



The GIGRAC 600 is a 600-watt stereo P.A. mixer/amplifier with 8 phantom-powered mic/line combo inputs, 2-band per-channel EQ, and a master 7-band graphic EQ before the mix output. The unit features internal reverb, chorus, effects processing, and a removable protective outer shell—allowing rack-mounting. Compact and robust, the GIGRAC is a feature- and value-laden P.A. alternative for gigging musicians, small houses of worship, and school auditoriums.

- 600-watt stereo powered mixer
- (8) XLR/1/4" combo inputs with phantom power
- Built-in multi-effects engine
- Flexible tabletop or rack-mount design
- Main, Record and Monitor outputs

**SAMSON**  
**XM410**

#SAXM410  
**\$299<sup>00</sup>**



The XM410 is a lightweight 400-watt powered mixer designed for small venue, DJ, and AV presentation applications. It is equipped with six Mic/Line inputs, 3-band EQ on each channel, 24-bit digital effects and 7-band graphic EQ's on both the main & monitor sections. This unit is built into a high-impact ABS cabinet with carrying handles.

- Output power: (2) x 200 watts or 400 watts bridged
- (6) Mic/Line inputs w/ XLR & 1/4" connectors
- RCA inputs & outputs for CD or tape players
- 24-bit DSP w/ 100 presets
- 3-Band EQ on each channel • 40 lbs

**XM610** 600-watt version #SAXM610 .....**\$399.00**  
**XM910** 900-watt version #SAXM910 .....**\$499.00**

**YAMAHA**  
**EMX-512SC**

#YAEMX512SC  
**\$569<sup>00</sup>**



The EMX-512SC is a high-quality two-channel powered mixer that provides 500 watts per channel, built-in graphic EQ and 16 top-quality Yamaha SPX effects. It features a power mode switch that allows it to operate as a stereo amplifier or as two independent amplifiers; one channel for the mains, and the other to drive a separate monitor mix.

- 8-channel (4 stereo/4mono) powered mixer
- (8) XLR inputs, (1-4 w/ phantom power)
- Inputs for instrument and line sources
- Output power: (2) x 500 watts
- One-knob compression on mono channels
- Yamaha Speaker processing
- 22 lbs

**EMX-312SC** 300-watt version #YAEMX312SC .....**\$469.00**  
**EMX-212S** 200-watt version (no compression) #YAEMX212S .....**\$369.00**

**SOUNDCRAFT**  
**GIGRAC 1000ST**

#S0GR1000ST  
**\$499<sup>00</sup>**



The Soundcraft Gigrac 1000ST is an extremely portable, lightweight, stereo, 500-watts-per-channel powered mixer with 8 combo mic preamps, built-in dual 7-band graphic EQ, high-quality digital effects, and rugged carrying case. The Gigrac is an ideal choice for the musician in need of true "plug & play" performance at an affordable price.

- 1000 watts @ 4 ohms
- 48V Phantom Power on Channels 1-4
- Individual Main and Monitor volume controls
- Neutrik Speakon or 1/4" Output Connections
- 20dB Pad on Channels 1-4
- 26.4 lbs

**MACKIE**  
**PPM Series 406M**

#MA406M  
**\$519<sup>99</sup>**



The PPM Series 406M is a flexible 500-watt powered mixer equipped with six Mic/Line inputs with master phantom power and inserts, a built-in effects processor, two independent 9-band EQ's (on mains & monitor outputs), and 3-band EQ's on each channel. It is an ideal choice for small PA, DJ, houses of worship, and AV presentation applications.

- (6) Mic/Line inputs on 1/4" and XLR connectors
- (2) 1/4" Speaker outputs per side
- Power output: (2) x 250 watts
- Power amps switchable as mains or main + monitor
- 32-bit digital effects processor
- RCA stereo tape I/O
- (2) 9-band master graphic EQs
- 32 lbs

**808M** 1200-watt mono version #MA808M .....**\$779.99**  
**808S** 1200-watt stereo version #MA808S .....**\$879.99**



**YAMAHA****STAGEPAS 300**

Providing versatile, convenient sound reinforcement for a wide variety of live sound applications, the self-contained, lightweight, Yamaha STAGEPAS 300 Portable PA System is the ideal presenter/musician travel companion. It combines a removable 8-channel 150-watt stereo mixer, cabinets with 8" woofers and 1" horns, low-noise mic/line inputs, responsive EQ controls, and a unique Speech/Music "Bass Boost" Switch, providing the enhanced low end needed for small DJ/sound reinforcement and live music playback.

- (4) XLR mic and two stereo 1/4" phone/RCA line inputs
- 150 watts x 2 @ 6 ohms • Built-in powered mixer can be used mounted on or off speaker cabinet • Two-way bass-reflex speakers with 8" LF and 1" HF drivers • Convenient speaker storage compartment for included power and speaker cable
- 40 lbs (mixer and two speakers)



#YASP300  
**\$549<sup>00</sup>**

**JBL****E-System15**

A complete, compact sound-reinforcement package suitable for gigging musicians, small performance venues, and traveling ministries, the JBL E-System15 is a choice PA rig for moderate to high-level, high-energy performances. Equipped with the Soundcraft E-8 10-channel mixer (featuring the ever-popular warm "British" sound), two AKG D2000S dynamic hypercardioid microphones, two great-sounding powered EON15-G2 speakers, and all the necessary cabling for a complete, professional mobile sound system.

- (8) low-noise mono mic/line input channels and two stereo line inputs
- 400 watts per speaker • 3-band EQ with sweepable mid-range
- Precision, ultra-linear mic pre-amps
- 15" LF driver, switchable balanced XLR and TRS phone Mic/Line inputs
- 110 lbs (mixer, two speakers, two mics and four cables)

**ES10** Soundcraft 8-channel mixer, two JBLEON10G2 Speakers etc.  
#JBES10.....**\$1379.00**



#JBES15  
**\$1799<sup>00</sup>**

**B-52****Matrix Systems**

The B-52 Matrix Systems are 3-piece active portable P.A. systems designed for small-venue DJ and band performances. The systems feature super-efficient 2- or 3-channel amplification, high-performance compression drivers, limiting and protection circuitry, and, in the case of the Matrix-200, a 5-channel mixer and built-in 24-bit effects.

**Matrix-200 features:**

- (2) 6.5" drivers, 1" phenolic tweeter per speaker • 5-channel mixer, 24-bit built-in effects • (4) XLR mic inputs with phantom power
- 3-band Master EQ section

**Matrix-1000 V2 features:**

- 3-way system with separately-powered subwoofer
- 10" driver, 1" titanium tweeter per speaker, 15" subwoofer
- Built-in 3-channel amplifier • Transport case supplied

**Matrix 2000 features:**

- 3-way system with separately-powered subwoofer
- 12" driver, 1" titanium tweeter per speaker, 18" subwoofer
- Built-in 3-channel amplifier • Transport case supplied

**Matrix-200** 200-watt system #B5M200.....**\$499.99**

**Matrix-1000V2** 700-watt system #B5M1000V2.....**\$849.99**

**Matrix-2000** 1200-watt system #B5M2000.....**\$1499.99**

**PEAVEY****Escort**

The Peavey Escort is a completely self-contained portable PA system. It features a rugged, molded case with handle and wheels that can be transported like carry-on luggage. Inside, you have a 5-channel mixer with effects and two 10" speakers powered by a 150-watt amplifier. Outside, you have storage compartments for microphones, cables and accessories. Ideal for presentations and smaller musical performances, the system comes complete with connecting cables, speaker/mixer stands and a PVi dynamic microphone with cable.

- 5-channel, 150-watt portable PA system with dual 10" speakers and built-in effects • (4) XLR inputs with 15V phantom power, (2) stereo line-level inputs • Convenient package with luggage-style handle and wheels for easy transportation • 5-band graphic EQ with Feedback Locating System
- Each input has bass, treble, and reverb controls • 80 lbs



#PEESCORT  
**\$649<sup>95</sup>**

**MACKIE****SAz Series**

Ideal for mid-sized to larger venues, the SAz Series are professional two-way and three-way active loudspeakers designed to maximize power performance from highly-efficient drivers, specially-calibrated electronics, and custom-designed and tuned cabinets. The 3-way models feature optimized WaveFront horns, providing a more natural sound by eliminating the need for a crossover at the critical vocal frequencies. Advanced electronic crossover filters, time correction, phase alignment, and thermal system protection are standard on all models.



- Highly accurate and powerful 2-way and 3-way loudspeakers with discrete amplification
- Wide dispersion, ultra-low distortion, high frequency horn design
- Power On, Signal Present, Limiter, and Thermal Protection LED's
- Durable, weight-balanced cabinets with multiple carrying handles
- XLR I/O

<b>SA1521Z</b> 400-watt 15" bi-amplified speaker (44Hz–20kHz) #MASA1521Z.....	<b>\$999.99</b>
<b>SA1530Z</b> 1300-watt tri-amplified speaker (38Hz–20kHz) #MASA1530Z.....	<b>\$1399.99</b>
<b>SA1532Z</b> 1300-watt tri-amplified dual 15" speakers (38Hz–20kHz) #MASA1532Z.....	<b>\$1949.99</b>

**ELECTRO-VOICE****SxA Series**

Built for easy transportation, the SxA Series are self-contained, bi-amplified loudspeakers designed for maximum clarity and projection. Both the SxA100 and 250 provide an XLR mic input and built-in two-channel mixer with two-band EQ, allowing for easy connection to keyboards, CD players, microphones, and more. The SxA100 is geared more toward speech reproduction for audio/video presentations, wedding receptions, and houses of worship.

The Sx250 provides a fuller, warmer sound with a higher output that's ideal for DJ's and lounge/bar sound reinforcement.

- Extremely smooth sound reproduction with perfectly-matched, high-current amplifiers
- Extended, high-frequency horns with better throw and control than typical systems
- Ring-Mode Decoupling identifies and dampens acoustic and mechanical resonance
- Well-controlled Limiters prevent clipping and preserve tonal balance
- Built-in 2-channel mixer with EQ and 1/4"/XLR Combo inputs

<b>SXA100P</b> 200-watt, 12" 2-way loudspeaker (65Hz–20kHz) #ELSXA100P.....	<b>\$625.00</b>
<b>SXA250</b> 200-watt, 15" 2-way loudspeaker (55Hz–20kHz) #ELSXA250.....	<b>\$799.00</b>
<b>SXA360</b> 500-watt, 12" 2-way loudspeaker w/Digital Amplification (60Hz–18kHz) #ELSXA360.....	<b>\$1195.00</b>

**YAMAHA****MSR Series**

The MSR Series are versatile, portable all-in-one PA systems that combine a mixer, amplifier, and speaker system into a single unit, perfect for small to medium-sized events, DJ's, lounges and bars. The ultra-compact MSR100 is a perfect stage monitor for keyboards, while the larger bi-amplified MSR400 can be used alone as a main speaker or combined with the powerful MSR800W subwoofer, extending the low-end and providing maximum punch. Rear panel controls include low and high EQ adjustments, 1/4" and XLR inputs with individual level control, and mic/line input pads.



- Versatile, all-in-one designs for monitor or main use
- Amplifiers ideally matched to their speaker components
- MSR400 can be stacked or pole-mounted
- Speakers feature visual clip indicators
- Mic/line level XLR/1/4" inputs with 2-band Master EQ

<b>MSR100</b> 8" 100-watt, two-way speaker (55Hz–20kHz) #YAMSR100.....	<b>\$369.00</b>
<b>MSR400</b> 12" 300-watt, two-way speaker (50Hz–20kHz) #YAMSR400.....	<b>\$549.00</b>
<b>MSR800W</b> 15" 500-watt, subwoofer (40Hz–120Hz) #YAMSR800W.....	<b>\$849.00</b>

**SAMSON****dB500a**

#SADB500A  
**\$449.00**

The dB500a is a bi-amplified, two-way loudspeaker with a custom 15" woofer and highly-efficient Neodymium high-frequency driver capable of providing 500 watts of combined power. Its exclusive Optimax signal processing circuitry and crossover design protects speaker components but doesn't cut out the low end at higher volumes, as similar speakers with variable filters do. The rigid custom cabinet is designed for both main or monitor use, can be easily stacked, pole-mounted, or flown via 10 reinforced fly points.

- 500-watt total power
- Ideal for small clubs/lounges, gigging musicians, worship ministries
- Selectable low-pass controls and Optimax dynamics (compression) included
- Balanced XLR and 1/4" combo inputs, XLR output
- 60Hz–24kHz

<b>dB300a</b> 300-watt, 12" version or above with titanium HF driver #SADB300A.....	<b>\$449.00</b>
<b>dB1500a</b> 1000-watt peak powered subwoofer with 15" speaker (20–200Hz) #SADB1500A.....	<b>\$569.00</b>
<b>dB1800a</b> 1000-watt peak powered subwoofer with 18" speaker (20–200Hz) #SADB1800A.....	<b>\$649.00</b>

**MACKIE**  
**SRM450V2**

#MASRM450V2  
**\$749<sup>99</sup>**

The SRM450V2 is a 2-way 12" bi-amplified P.A. loudspeaker with 400-watts of combined power output, suitable for portable live sound reinforcement and floor stage monitor applications. Ruggedly and ergonomically designed, the speaker features a wide-dispersion horn and Mackie's proprietary Active Electronic time-alignment, EQ and phase correction. The unit's flexible mounting options include pole-mounting, suspension, and vertical or wedge-style stage placement.

- 400-watts total power • 12" woofer, 1.75" horn-loaded titanium tweeter • XLR input, XLR pass-through
- 55Hz-18kHz frequency response • Built-in protection circuitry, limiter and High-pass filter • Lightweight, rugged polypropylene enclosure
- Perforated metal grille with moisture-resistant coating



**SRM350V2** 2-way 10", 195-watt version #MASRM350V2 .....**\$599.99**



**JBL**  
**EON15 G2**

#JBEON15G2  
**\$729<sup>00</sup>**

The multi-purpose JBL EON15 G2 is a bi-amplified, 400-watt PA loudspeaker system featuring a 15" woofer, wide coverage pattern, and detailed high-frequency response. This full-range, lightweight speaker is both versatile and powerful, making it an excellent portable choice for small-venue performances and intimate events.

- 400-watt, bi-amplified 15" loudspeaker
- Ideal for live sound reinforcement, speech, vocal and music playback systems • Dual-purpose designed enclosure doubles as floor monitor
- Balanced XLR and 1/4" mic/line inputs • 39Hz-18kHz

**EON10G2** 175-watt, 10" version (65Hz-18kHz) #JBEON10G2.....**\$549.00**

**EON15P1** original 180-watt, 15" version (47Hz-kHz) #JBEON15P1 .....**\$489.95**

**EONSUBG2** 250-watt, 15" portable subwoofer (40Hz-200Hz) #JBEONSUBG2.....**\$679.00**

**JBL**  
**PRX535**

#JBPRX535  
**\$1239<sup>00</sup>**

The PRX535 is a 3-way, 650-watt active P.A. monitor designed for professional sound reinforcement applications. The speaker features a proprietary DSP controller chip regulating EQ, crossover, dynamic limiting and component optimization. The unit is loaded with a Crown Class B digital amplifier powering a 15" differential-drive woofer, a 6.5" mid-range driver, and a neodymium compression driver mounted into a 90° x 50° radial horn.

- 650-watts total power • 15" woofer, 6.5" midrange, horn-loaded tweeter • XLR/TRS Combo input jack with XLR loop out
- 46Hz-20kHz frequency response
- Sturdy plywood enclosure with DuraFlex finish
- Machine-tooled steel grille with acoustically-transparent foam lining



**PRX525** Dual 15" 2-way, 650-watt version #JBPRX525.....**\$1239.00**

**PRX515** 2-way, 500-watt version #JBPRX515.....**\$1039.00**

**PRX512M** 2-way 12", 500-watt version #JBPRX512M.....**\$929.00**

**RCF**  
**ART 312-A**

#RCART312A  
**\$739<sup>95</sup>**

The ART 312-A is a bi-amplified, 350-watt loudspeaker complete with electronic processing and custom component-matched amplifiers. Housed in a strong, lightweight polypropylene enclosure, the ART 312-A delivers a natural, open sound with smooth, controlled bass, ideal for any high-quality monitoring application.



- 350-watt, 12" loudspeaker
- Electronic EQ, phase alignment, limiter, and protection
- Efficient, wide-dispersion horn driver
- Easy to transport and setup, flyable or pole-mounted
- Balanced XLR/1/4" mic/line input, XLR chain output

**ART310A** 350-watt, 10" version of above #RCART310A.....**\$529.50**

**ART315A** 350-watt, 15" version of above #RCART315A.....**\$774.50**

**BEHRINGER**  
**B212A**

#BEB212A  
**\$229<sup>99</sup>**

Ideal for speech reproduction and smaller lounge/bar sound reinforcement, the affordable B212 loudspeaker combines a 12" speaker, 450 watts of power, and an integrated sound processor with speaker protection. Its versatile ergonomic enclosure is designed to work equally as well stand mounted or as a stage monitor.



- 450-watt, bi-amplified 12" loudspeaker with built-in 2-band EQ • Built-in Limiting amplifier with speaker protection circuitry and clip LED
- Durable, polymer ported enclosure for pole or side-mounting
- Balanced XLR/1/4" inputs, XLR chain output

**B215A** 450-watt, 15" version of above #BEB215A.....**\$279.99**



**JBL****MRX500 Series**

The MRX500 Series passive loudspeakers are designed for live PA and portable DJ applications that require superior full-range audio from a design that's easy to transport, set up, and adjust to almost any room. Advanced cabinet and transducer engineering results in significant weight savings over traditional designs, yet performance, power handling, and ruggedness have been optimized.



- Perfectly-matched transducers and drivers greatly improve sound quality and power handling
- Custom waveguides provide superior, even coverage throughout frequency range
- Dual-angle mount on MRX512M and MRX515 offers increased control, coverage, and clarity
- Advanced mechanical design reduces cabinet weight significantly
- All input and loop-thru connections are made via reliable Neutrik NL4MP connectors

<b>MRX512M</b> 12" 400-watt main/monitor (60Hz–20kHz) #JBMRX512M.....	<b>\$649.00</b>
<b>MRX515</b> 15" 400-watt main (52Hz–20kHz) #JBMRX515.....	<b>\$689.00</b>
<b>MRX518S</b> 18" 500-watt subwoofer (40Hz–200Hz) #JBMRX518S.....	<b>\$649.00</b>
<b>MRX525</b> dual 15" 800-watt main (40Hz–20kHz) #JBMRX525.....	<b>\$949.00</b>
<b>MRX528S</b> dual 18" 1000-watt subwoofer (35Hz–250Hz) #JBMRX528S.....	<b>\$949.00</b>

**ELECTRO-VOICE****Sx Series**

The passive Sx Series comprises professional loudspeakers designed to deliver superior intelligibility and performance in a wide variety of Live Sound, Speech, A/V, DJ, and Institutional Venues. Ring-Mode Decoupling (RMD) provides improved clarity by removing mechanical and acoustic resonance while the VariPath horn extends coverage to areas missed by typical loudspeakers, resulting in a more natural sound that cuts through noisy, reverberant rooms. The Sx Series are extremely portable and offer easy pole mounting or suspension.

- High-power-handling loudspeakers that are open and musical
- VariPath horn drivers deliver better pattern control and projection
- RMD reduces resonance and muddiness, improving vocal and instrument accuracy
- Flexible mounting for install or portable live use
- Neutrik Speakon connectors

<b>SX100+</b> 200-watt, 12" version (60Hz–20kHz) #ELSX100PE.....	<b>\$420.00</b>
<b>SX250</b> 350-watt, 15" multi-angle enclosure (floor monitor use) (50Hz–20kHz) #ELSX250.....	<b>\$590.00</b>
<b>SX300</b> high-powered, 300-watt, 12" version (50Hz–20kHz) #ELSX300E.....	<b>\$580.00</b>
<b>SX500</b> 400-watt, 15" version (43Hz–20kHz) #ELSX500P.....	<b>\$990.00</b>

**SAMSON****Resound Series**

The Resound Series are passive loudspeakers that present an affordable combination of high power handling, advanced crossover design, and quality speaker and cabinet components. Each loudspeaker features a heavy-duty, custom-designed, low-frequency driver for tight, punchy bass and an open-sounding, wide-dispersion horn. The result is a clear, wide sound field, ideal for any kind of live application.



- Clean, articulate sound reinforcement for vocal and music reproduction
- Internal 18dB/octave crossover with high frequency lamp protection
- Ergonomic carrying handles and stand mounts on trapezoidal and monitor enclosures
- Neutrik Speakon and 1/4" inputs and outputs

<b>RS10</b> 10" 2-way, 125-watt loudspeaker (all ratings at 8-ohms except RS215) #SARS10.....	<b>\$149.00</b>
<b>RS10M</b> 10" 2-way, dual-angle 125-watt floor monitor (60Hz–20kHz) #SARS10M.....	<b>\$149.00</b>
<b>RS12M</b> 12" 2-way, dual-angle 175-watt (50Hz–20kHz) #SARS12M.....	<b>\$179.00</b>
<b>RS15M</b> 15" 2-way, dual-angle 225-watt floor monitor (40Hz–20kHz) #SARS15M.....	<b>\$229.00</b>
<b>RS15S</b> 400-watt, 15" subwoofer (40–250Hz) #SARS15S.....	<b>\$299.00</b>
<b>RS18S</b> 400-watt, 18" subwoofer (35–250Hz) #SARS18S.....	<b>\$349.00</b>
<b>RS215</b> 350-watt @ 4 ohm dual 15" loudspeaker #SARS215.....	<b>\$349.00</b>

**YAMAHA****Club V Series**

The Club V Series is the latest in a popular line of quality, value-oriented loudspeakers selected by gigging bands, mobile DJ's, and houses of worship for their rugged durability, professional features, and sonic performance. Available as monitors or mains, they feature cabinets constructed of high-quality particle board, custom-designed drivers with high strength cones and voice coils, and crossover networks that affect sound reproduction minimally while maintaining a full-frequency response.

- Improved low-frequency drivers, power handling and crossover design
- Ideal for any-sized club, lounge, or house of worship
- Integral pole-mount sockets and rugged steel corners
- Custom designed driver components
- Dual Neutrik Speakon 1/4" jacks

<b>SM15V</b> 15" two-way, 500-watt floor monitor (55Hz–16kHz) #YASM15V.....	<b>\$349.00</b>
<b>SM12V</b> 12" two-way, 350-watt floor monitor (60Hz–16kHz) #YASM12V.....	<b>\$299.00</b>
<b>SM10V</b> 10" two-way, 250-watt floor monitor (70Hz–20kHz) #YASM10V.....	<b>\$249.00</b>
<b>SW118V</b> 18" 600-watt subwoofer (30Hz–2kHz) #YASW118V.....	<b>\$399.00</b>
<b>S112V</b> 12" two-way, 350-watt speaker (60Hz–16kHz) #YAS112V.....	<b>\$299.00</b>
<b>S115V</b> 15" two-way, 500-watt speaker (55Hz–16kHz) #YAS115V.....	<b>\$329.00</b>

**MACKIE****S215**#MAS215  
**\$499<sup>99</sup>**

The S215 is a high-output passive loudspeaker designed from the ground up to offer some of the best performance in its class. Its ruggedly-built enclosure incorporates high-quality connectors and a custom 15" woofer and wide-dispersion 1.75" titanium driver, providing the full-range response and clarity required for DJ's, working musicians and live sound reinforcement applications.

- 350 watts @ 8 ohms
- Custom designed cabinet, crossover, and speaker components
- 18mm multi-layer Baltic Birch construction
- Neutrik Speakon and 1/4" inputs • 80Hz–18kHz



**S225** 700-watt dual 15" woofer version (70Hz–18kHz) #MAS225.....**\$749.99**

**S218S** 500-watt 18" subwoofer (38Hz–360Hz) #MAS218S.....**\$599.99**

**SAMSON****dB500**#SADB500  
**\$369<sup>00</sup>**

The dB500 is a passive two-way loudspeaker with a custom 15" woofer and highly-efficient Neodymium high-frequency driver capable of providing 500 watts of combined power. The rigid custom cabinet is designed for both main or monitor use, can be stacked easily, pole mounted, or flown via 10 reinforced fly points.



- 500 watts @ 8 -ohms
- Extensive high-frequency coverage with linear off-axis response
- Speakon input, 1/4" parallel output
- Compact, easy-to-transport with 3 oversized rubber handles • 60Hz–15kHz

**dB300** 300-watt 12" version of above  
#SADB300.....**\$299.00**

**MACKIE****C200**#MAC200  
**\$299<sup>99</sup>**

The C200 is a passive 10" loudspeaker designed to help upgrade DJ's' or gigging musicians' existing powered mixers and amplifiers immediately. They benefit from a precisely-tuned crossover and enclosure design resulting in an open, natural sound uncommon for speakers in this price range. The C200's compact, ergonomic design makes them useful in both pole-mounted or floor monitoring applications.

- 200 watts @ 8 ohms
- Asymmetrical cabinet design for best acoustic response
- Tough, impact-resistant enclosure with sturdy handles
- Neutrik Speakon and 1/4" inputs • 89Hz–20kHz



**C300Z** 300-watt version with 12" woofer 1.75" HF driver (55Hz–18kHz)  
#MAC300Z.....**\$479.99**

**JBL****EON1500**#JBEON1500  
**\$410<sup>00</sup>**

The EON1500 is the passive 15" version of the popular EON Series loudspeakers. Its unique multi-angle enclosure gives them the flexibility to be used in pole-mounted, wall-mounted, or two-angle floor monitor applications. The speaker handles 225 watts of power, features a liquid-cooled titanium diaphragm compression driver and is protected by unobtrusive SonicGuard circuitry.

- 225 watts @ 8 ohms
- Molded one-piece baffle with 60° x 90° constant directivity horn
- Lightweight, ergonomic design ideal for portable PA applications
- Neutrik and 1/4" inputs • 55Hz–16kHz

**TAPCO****TH15A**#TATH15A  
**\$349<sup>99</sup>**

The TH15A is a 2-way bi-amplified 200-watt P.A. loudspeaker, with a 15" woofer and a 1" horn-loaded compression driver housed in a sturdy polypropylene cabinet with a bass-reflex design. The speaker represents a solid investment for bands on a budget, delivering clean, high-powered sound with plenty of low-end thump and smooth, wide high frequency dispersion.



- 200-watts total power • 15" paper cone woofer, 1.75" horn-loaded compression driver
- XLR input • 50Hz-18.5kHz frequency response
- Active crossover, time-alignment and compression
- Angled enclosure for stage monitor use or pole-mounting

**ELECTRO-VOICE****SbA 760**

The SbA 760 is a high-performance, 760-watt, 15" powered subwoofer ideally-suited for the Sx Series loudspeakers. It combines an artful H power amplifier, patented LPN (low-pass-notch) filter, and the PowerMax crossover filter, achieving a higher acoustic output than expected for its size.

- 760-watt, 15" powered subwoofer
- Highly-efficient Class-H amplifier with dynamic limiting
- LPN filter reduces distortion and extends bass response
- XLR combo inputs and XLR thru connectors
- 42Hz–150Hz



#ELSBA760  
**\$1430<sup>00</sup>**

**JBL****JRX118SP**

The JRX118SP is an 18", 300-watt powered subwoofer designed to extend the low frequency performance of full-range systems in live sound and music playback applications. It features a stereo crossover, built-in peak limiter and clearly-labeled connectors, controls and indicators.

- 300-watt, 18" powered subwoofer
- Solid, durable construction made from 3/4" MDF
- Peak limiter with Limiting LED indicator
- 1/4" and balanced XLR connectors • 55Hz–300Hz



#JBXR118SP  
**\$769<sup>00</sup>**

**MACKIE****SWA1801Z**

The SWA1801Z is an active 18" subwoofer driven by a highly-efficient 800-watt amplifier and optimized with electronic control over crossover filters, EQ, and component protection. Its rigid, compact design and ease of portability make it a great choice for most powerful low-end sound applications.

- 18" subwoofer with 800-watt amplifier
- Active Electronic Crossover Network • Balanced XLR I/O
- Simple setup with no need for external crossover • 35Hz–120kHz

**SWA1501** 500-watt, 15" version (36Hz–120kHz)

#MASWA1501 .....**\$1049.99**

#MASWA1801Z  
**\$1399<sup>99</sup>**

**RCF****ART 705 AS**

The ART 705 AS is a professional 800-watt, 15" powered subwoofer designed with a high-current, 2-step class H TAED amplifier that quickly delivers the precise amount of power with very low distortion. An electronic processor section controls system EQ, limiter, and protection functions.

- 800-watt, 15" powered subwoofer
- High-current amplifier with active system processing
- Compact design with 4 system status LED's
- XLR inputs and pass-through connectors • 40Hz–120Hz

#RCART705AS  
**\$974<sup>95</sup>**

**SAMSON****dB1800A**

The dB1800 is a powered 18" subwoofer capable of producing 1000 watts of low-end sound reinforcement. It features a variable active crossover for adding satellite speakers, steel corners, large casters and a pole-mount receptacle. Ideal for both mobile PA and fixed installs.

- 1000-watt, 18" powered subwoofer
- Variable stereo crossover (30Hz–200Hz) with high-pass output
- Heavy-duty rear-mounted casters • Balanced XLR I/O



#SADB1800A  
**\$649<sup>00</sup>**

**dB1500** 1000-watt 15" version #SADB1500A.....**\$569.00**

**YAMAHA****MSR800W**

The MSR800W is a 500-watt, 15" powered subwoofer that extends the bass response of any loudspeaker system easily for maximum impact. Source signals are high-pass filtered and passed on to the main satellite speakers resulting in a more musical, efficient sound system.

- 500-watt, 15" powered subwoofer
- Thick, birch plywood bass-reflex style enclosure
- Master Level and variable Cutoff Frequency controls
- XLR inputs and pass-through connectors • 40Hz–120Hz



#YAMSR800W  
**\$849<sup>00</sup>**



**ELECTRO-VOICE****Sb122**

The Sb122 is a passive 400-watt subwoofer compact enough to fit in your front seat. It's designed to add bass to EV Sx and Zx Series speaker systems and benefits from high-current connectors, a long-throw 12" woofer, and a strong, lightweight composite enclosure.

- 400-watt, 12" passive subwoofer
- One of the most compact, powerful subwoofers available
- Top-mounted pole cup, ergonomic carrying handles and built-in low-pass filter • Parallel Neutrik Speakon connectors • 52Hz–145Hz



#ELSB122B  
**\$359<sup>00</sup>**

**JBL****JRX118S**

The JRX 118S is an 18", 350-watt direct-radiation subwoofer designed to enhance the low-end of full-range sound systems, improving overall efficiency. Ideal for both portable PA and permanent install applications, it features a durable, carpeted enclosure, built-in pole-mount and steel handles.

- 350-watt, 18" passive subwoofer
- Enclosure utilizes advanced adhesives and mechanical fastener technology
- Non-resonant, all-steel handles
- Neutrik Speakon and 1/4" connectors • 55Hz–300Hz



#JBRX118S  
**\$459<sup>00</sup>**

**MACKIE****S218s**

The S218s is a passive 500-watt, 18" subwoofer designed to add greater low end to any existing sound system. It features a bass-reflex enclosure with dual carrying handles and advanced crossover and filter design, eliminating the need for external processing of full-range signals.

- 500-watt, passive 18" subwoofer
- Precise low-end and compact size
- Built-in crossover and low-pass filter
- 1/4" and Neutrik Speakon connectors • 38Hz–360Hz

#MAS218S  
**\$599<sup>99</sup>**

**SAMSON****RS15S**

The RS15s is an affordable 400-watt passive subwoofer that's ideal for mobile DJ rigs or adding extended low end in houses of worship and lounges. It features a heavy-duty, long-throw 15" woofer in a precision-tuned port enclosure, complete with pole-mount socket and rugged carpeting.

- 400-watt, passive 15" subwoofer
- Precision-tuned shelf-port design voiced for articulated bass
- Inexpensive solution for extended low-bass performance
- 1/4" and Speakon inputs with 1/4" satellite thru • 55Hz–150Hz

#SARS15S  
**\$299<sup>00</sup>**

**RS18S** 18", 400-watt passive version (35Hz–250Hz) #SARS18S...**\$349.00**

**TURBOSOUND****TXD-215**

The TXD-215 is a powerful 600-watt, dual 15" passive subwoofer designed for live sound reinforcement and music playback. Its optimally-tuned enclosure features an internal low-pass crossover, flyable rigging points, four flush handles, and three integral pole-mount sockets.

- 600-watt, dual 15" passive subwoofer
- Passive crossover network eliminates need for outside processing
- Heavy-duty casters and metal grille
- Neutrik Speakon connectors
- 40Hz–150Hz



#TUTXD215  
**\$769<sup>00</sup>**

**TXD218** 600-watt dual 18" version (36Hz–150Hz) #TUTXD218...**\$1059.00**

**YAMAHA****SW118V**

The SW118V is a value-oriented, 300-watt passive 18" subwoofer with the ideal low-end extension for bars/lounges, gigging bands, and permanent installs. Its rugged, carpet-covered enclosure features metal corners, a pole-mount socket and all-steel handles.

- 300-watt, 18" passive subwoofer
- High-quality crossover and overload protection
- Efficient, bass-reflex enclosure
- Neutrik Speakon and 1/4" connectors
- 30Hz–2kHz (frequency range -10dB)



#YASW118V  
**\$399<sup>99</sup>**

## ASHLY MX-206

#ASM206  
**\$540<sup>00</sup>**



The 6-channel MX-206 is ideal for both stand-alone and sub-mixing use in broadcast, film, and conference environments where low-level signals need significant gain increases with very low noise or distortion. Each of its six input channels features an XLR mic input, a 20dB pad and 48V phantom power for condenser mic use. Audio is then clearly routed to either a mono XLR or stereo 1/4" TS/TRS output.

- 6-input microphone mixer
- Up to 84dB of gain ensuring full output with low level signals
- XLR inputs, 20dB pads, and phantom power on each input
- Pan and level controls on a single knob
- Left/Right level meters w/clip indicators
- Headphone output with level control

## ASHLY MX-406

#ASM406  
**\$785<sup>00</sup>**



The MX-406 is a professional-grade six-input stereo mic/line mixer that's ideal for both fixed or portable setups. Loaded with features, the MX-406 provides each input channel with XLR combo jacks with inserts, 20dB pad switches, 2-band shelving EQ's, and three-position gain switches for 20, 40, or 60dB attenuation. The stereo and mono outputs are on 1/4" and XLR connectors respectively.

- 6-channel mic/line mixer with XLR combo jack inputs
- 2-band EQ on each input
- Input level and pan control on each input
- Aux line I/O on RCA connectors
- (6) channel inserts for dynamic or effects processing
- Channel clip, phantom power, AC power, and 11-step output level meter LED's

## RANE MLM 42

#RAMLM42  
**\$375<sup>00</sup>**



The MLM 42 is a professional 4-channel mic/line

mixer that easily expands the number of mics for existing gear. Its inputs are balanced XLR or TRS 1/4" and feature both 15V phantom power and 3-band Accelerated Slope full-cut tone controls (an EQ with a steeper slope that reduces interference of nearby frequencies). Each input has an overload indicator and post-mix effects loop that includes wet/dry pan control.

- Ideal for commercial installs, live sound, and DJ mixer (Mic) expansion
- Features four high-quality dedicated mic preamps and line inputs
- Line and mic inputs are balanced XLR and TRS 1/4"
- RCA, XLR & TRS 1/4" balanced parallel outputs (selectable mic/line)
- Steep, 3-band Accelerated-Slope tone controls

## SHURE SCM268

#SHSCM268  
**\$249<sup>95</sup>**



Ideal as a standalone or submixer for meeting rooms, houses of worship, broadcast, and educational paging and public address systems, the SCM268 is a very quiet 4-channel microphone mixer with 4 balanced XLR inputs

and a mic/line switchable XLR output. Built-in low cut filters and phantom power allow for low-noise operation of either condenser or dynamic microphones.

- 4-channel mono mic mixer with XLR I/O and 12V phantom power
- (5) aux inputs and (1) aux output on RCA (phono) connectors
- Individual channel level, aux and master controls
- Clean, transformer-balanced circuitry rejects RF interference
- Output level LED

## SHURE SCM410

#SHSCM410  
**\$666<sup>50</sup>**



The SCM410 is a 4-channel automatic mono mixer designed specifically for high-quality boardroom, house of worship, and institution audio mixing. The mixer effectively gates other channels while allowing the intended channel to come through, dramatically reducing noise, feedback, and reverberation. Connections are made via 4 balanced XLR inputs and 1 XLR (mic/line switchable) output. There is also an auxiliary RCA output.

- 4-channel mixer with automatic signal sensing (IntelliMix)
- Automatic gain adjustments when other mics are activated
- Very simple setup and operation for fixed or portable installs
- Adjustable EQ for each channel, master output LED
- (4) XLR inputs, (1) balanced mic/line XLR output, (1) RCA aux output

## RANE MLM 103

The MLM 103 is an 8-channel mic/line level mixer with the first six channels providing 12V phantom power, and switchable between mic/line level operation. All the inputs feature overload indicators, a steep 3-band EQ and selectable output bussing switches. The mic preamps are studio quality and can deliver a clean, wide gain range of 12 to 60dB. Balanced Euroblock connectors on the inputs and outputs make the MLM 103 ideal for high-quality permanent install applications.

- (6) mic/line input channels and (2) dedicated stereo line-level inputs
- Independent output level control
- Direct outputs (pre- or post-mix level)
- 12V phantom power
- EQ and Assign switch security cover included

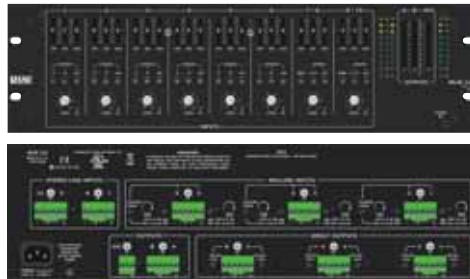

#RAMLM103  
**\$839<sup>00</sup>**

## SHURE SCM800



8-channel mic/line mixer that's perfect for general audio-visual, sound reinforcement, and recording applications. Its single-space design features 2-band EQ's, 48V phantom power, and 1/4" inserts on each channel. The SCM800 inputs and outputs are on block connectors and have appropriate level LED's, including a peak-limiter with LED and threshold adjustment.

- 8-channel balanced mic/line mixer
- Inputs and outputs on block connectors
- Adjustable EQ and roll-off on each channel
- LED indication of channel clipping, master output, and peak-limiting output
- Front-panel headphone output with level control
- Linkable to other systems

## SHURE SCM810

The SCM810 is an 8-channel mono mixer featuring Shure's auto-IntelliMix, a feature that activates only the channels being addressed, minimizing noise caused by other open channels. Its balanced mic/line inputs are on Phoenix block connectors and each channel has its own unbalanced 1/4" output for feeding additional amplifiers or consoles. 48V phantom power and a level-selectable peak limiter allow for greater control of condenser and dynamic mic outputs.

- 8-channel mic/line mixer on balanced Phoenix block connectors
- IntelliMix automatic channel activation
- Adjustable EQ and unbalanced 1/4" outputs on each channel
- One balanced master line/mic level output (Phoenix connector)
- 48V phantom power per channel



#SHSCM810  
**\$1196<sup>95</sup>**

## WHIRLWIND MIX-5S



The MIX-5S is a straightforward single-space rack mixer with four mic/line inputs and a stereo RCA aux input. A phantom power switch is available to power condenser microphones. The controls are simple to operate, and an LED meter provides a visual reference for sound levels. Its main XLR and 1/4" outputs can also be switched from mic or line, making it easy to integrate into different kinds of sound systems.

- (4) mic/line inputs with XLR and 1/4" connectors
- Left and right stereo RCA aux input with level control
- XLR and 1/4" main outputs
- Individual volume, pan, and main output controls
- A single 18V phantom power on/off switch for inputs 1-4

**MIX5** Mono version of the MIX-5S

#WHMIX5 ..... **\$289.95**

## WHIRLWIND MIX-6



The MIX-6 is a compact single-space stereo mixer with professional features and high-quality circuitry. Each of the four mic/line inputs features a low cut filter switch, pan control, and volume knob. A stereo limiter can be engaged on the master output, and a headphone monitor allows you to listen to an aux input, and then add that aux input into the mix. Ideal for professional applications in limited space.

- (4) XLR and 1/4" inputs with mic/line switch
- (2) aux inputs, RCA and balanced or unbalanced 1/4"
- Left and right main outputs have individual mic/line switches
- Stereo limiter switch and dual LED meter display
- A single 48V phantom power on/off switch for inputs 1-4

#WHMIX5S  
**\$319<sup>95</sup>**

#WHMIX6  
**\$649<sup>95</sup>**



## RANE SM 82

#RASM82  
**\$499<sup>00</sup>**



The SM 82 is an easy-to-operate, 16-channel single-space stereo mixer. It is ideally suited as a main mixer of keyboards, sound modules, drum machines, and other line-level signals or as a submixer of larger consoles. Its mere 5 1/4" depth provides a shorter signal path, resulting in a much cleaner overall sound. All eight stereo input channels provide a rotary Level control, a stereo aux Send slider, and a left-to-right Balance control slider.

- (8) stereo input channels (16 mono) 1/4" unbalanced
- Shallow depth provides shorter signal path, improving sound quality
- Fully expandable using 1/4" TRS expand input and output jacks
- Rotary level knob, send, and balance slider on each input channel
- Balanced stereo output
- Stereo aux send and returns

## TOA M-243

#TOM243  
**\$711<sup>00</sup>**



The M-243 is a highly-flexible 6-input mixer, with two mono inputs on either XLR mic or 1/4" line level connectors, and 4 stereo RCA line inputs. Each mono input features an automatic compressor, 20dB pad and high-pass filter. Ideal for multi-zone music and paging in restaurants, bars, health clubs, and conference rooms, the M-243 easily sums and routes mono or stereo signals to any choice of output zones while handling signal priority via switchable automatic muting.

- 6-input mixer with 2 mono and 4 stereo channels
- Output mixing buses with level controls: stereo, mono 1, and mono 2
- 3dB below clip output LED indicator
- Stereo output has separate stereo recording output and bass/treble EQ
- XLR, 1/4" and RCA connectors

## INTER-M PP-9213

#INPP9213  
**\$406<sup>95</sup>**

The PP-9213 is a feature-laden 9-channel mic/line mixer designed to operate equally well as a standalone or main console submixer.



The first two channels of the PP-9213 feature switchable priority ducking and phantom power and include mono XLR and balanced TRS 1/4" inputs. The stereo line inputs on channels 7-9 are balanced 1/4" TRS. Flexible output routing includes two monitor sub outputs, a record output, master insert and output.

- 9-channel mic/line mixer with phantom power and priority ducking
- Ideal for boardroom presentations/meetings, restaurants and bars
- 3-band EQ on each input, 4-band on master out
- XLR master output • 2-space rack that operates on AC or 24VDC power

## NUMARK CM200USB

#NUCM200USB  
**\$299<sup>95</sup>**



The CM200USB from Numark is an affordable 5-channel mixer that's ideal for installations or mobile DJ'ing purposes. It features two USB ports and two included USB cables for playing songs stored on a computer, and also

for recording the mixer's audio back into a computer. It also features multiple microphone inputs, zone outputs with dedicated volume control, fader start capabilities, gains and EQ on every channel, and a replaceable crossfader.

- (2) USB ports for computer connectivity
- (8) line, (3) record player, and (3) microphone inputs
- (2) balanced XLR master outputs
- Record, zone, and master RCA outputs
- 3-band EQ on every channel
- Mac and Windows compatible
- Plug-and-play (no software drivers needed)

**CM100** 4-channel non-USB mixer #NUCM100 ..... **\$179.95**

## ROLLS RM203x

#RORM203X  
**\$254<sup>95</sup>**



The RM203x is a 10-channel line-level mixer featuring nine stereo channels, one XLR mic input, a tape input, a mono auxiliary send and stereo returns. Each channel of this single-space mixer provides a clip LED indicator, signal level, left/right balance and auxiliary level controls. A Master Output section contains the tape input level, auxiliary return level, and master output volume controls.

- Ideal main keyboard/sound module mixer or main console submixer
- (9) stereo inputs and (1) XLR mic input with 12V phantom power
- RCA tape I/O • Headphone output
- Level, Balance, and Aux send controls per channel

**ROLLS****RM70**

The RM70 is a 7-input mic/line mixer featuring 3 XLR mic inputs, 4 stereo RCA line level inputs and balanced 1/4" outputs. Each mic input is switchable between mic/line levels and provides 12V phantom power and LED overload indicators. Featuring talk-over and Music-on-Hold capabilities supplied to Mic1 and Source1 inputs respectively, applications for the RM70 include aerobics classes, Karaoke lounges, restaurants, and bars.

- 7-input mic/line mixer with 12V phantom power
- (3) XLR mic inputs and (4) stereo RCA line level inputs with overload LED's
- Tone and level controls for mic inputs
- Bass, treble, and level control for Source inputs • 1/4" mic/loop insert

#RORM70  
**\$209<sup>95</sup>**

**BEHRINGER****Ultralink Pro MX882**

The MX882 is a multi-purpose device that works as a splitter, line mixer, or level conditioner. Channels can be individually assigned for mixing or splitting and can function simultaneously. Configured as an 8-in 2-out line mixer, 2-in 8-out line splitter or 6-in 6-out direct box, the MX882 provides a short, clean audio path with a wide bandwidth, ideal for home theater, studio, and restaurant/bar installs.

- Flexible mixer, router, and line converter
- 8 x 2 line mixer, 2 x 8 splitter, 6 x 6 direct box
- (4) 8-segment input/output LED's for all channels
- Unbalanced 1/4" and XLR balanced inputs and outputs
- Line matching transformer switches from consumer to pro level and vice versa

#BEMX882  
**\$99<sup>99</sup>**

**ART****Model 418**

Compact, straight forward and easy to operate, the 418 from ART is an 8-channel mic/line mixer that occupies a single rack space. The front panel features a level and tone knob for every input, and a master volume control. The back panel features 8 XLR mic inputs, and 8 unbalanced 1/4" line inputs. A dipswitch allows you to send phantom power to any XLR input. It's an ideal mixer for an audio installation at a church, fitness center, or a business.

- (8) XLR inputs, (8) unbalanced 1/4" inputs
- 12V of phantom power for each individual channel
- Two units can be linked together for 16 channels of audio
- Level and tone control on every channel • Balanced 1/4" TRS output

#ART418  
**\$169<sup>00</sup>**

**RDL****RU-MX5**

The RU-MX5 is ideal for applications needing to mix mic and/or line-level signals easily with the ability for additional expansion. All connections are made using full-size block terminals on the rear panel. Four inputs are mic/line selectable with the fifth being dedicated strictly to line-level sources. Both low- and high-impedance mic signals are supported, and a rear-panel jumper selectively connects the internally-provided 24Vdc phantom voltage to any or all the mic inputs. Ideal for broadcast and audio/video post facilities.

- Compact, 5-input mic/line mixer with superior audio clarity
- Separate unbalanced MIX input allows external audio source to be summed into the mix
- Audio presence and peak LED meters
- Channels 1-4 mic/line selectable, channel 5 line-level input
- Balanced mic and line-level outputs
- Barrier-strip block terminal input

#RDRUMX5  
**\$286<sup>61</sup>**

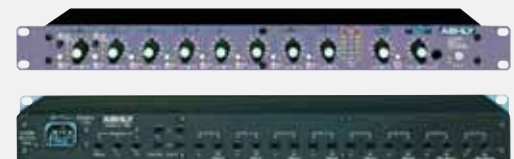
**ASHLY****LX-308B**

The LX-308B is a true stereo 8-channel line-level mixer which can also be used as a 16-channel mono mixer. Each channel features pan and level controls on a single knob, dual balanced 1/4" TRS inputs, and individual mute switch and signal level LED's. The first two channels are switchable between mic and line levels to allow use of microphones directly. The LX-308B provides high-quality audio mixing with precise control.

- 8 stereo channels or 16 mono mic/line mixer
- Great mixer for any line level source in a studio, boardroom, or even broadcast facility
- First two channels accept mic level inputs
- Pre-master sub inputs and outputs for linking
- Peak signal detection and mutes on each channel

#ASLX308B  
**\$515<sup>00</sup>**

## ROLLS MX152

#ROMX152  
**\$109<sup>95</sup>**



The MX152 is a compact mic/line mixer that provides an efficient way to mix sources such as CD players, AM/FM tuners, video players and dynamic or condenser microphones easily. It features two XLR mic inputs with phantom power and three stereo line source inputs. A series of six DIP switches provides important features including phantom power, summing, and ducking, ideal for use in bars and restaurants with jukeboxes and/or paging.

- (2) XLR mic inputs and (3) stereo line level inputs
- Tone controls for each mic input and bass and treble control of source 1 and 2
- Individual level controls for each input
- (6) DIP switches selects phantom power, summing and ducking • Source inputs and main outputs are on RCA connectors

## ROLLS RM67

#RORM67  
**\$199<sup>95</sup>**



The RM67 is a versatile single-rack space audio mixer featuring three XLR inputs and four stereo RCA source inputs. For paging and music priority functions, a convenient Talkover feature has been included on Mic 1 and Source 4. A remote volume jack has been included to connect an external control knob for the master volume control. Ideal for karaoke bars, aerobic studios, clubs, and restaurants, or audio/visual presentations.

- (3) XLR mic inputs with phantom power, (4) stereo RCA inputs
- Tone controls for mic inputs, bass and treble control of source inputs
- Pre-master mix output record capability
- 1/4" balanced outputs
- Remote master volume control jack
- Mic/line switch (30dB pad)
- Mute jack allows external paging
- Mic inserts for processing mic inputs

## AUSTRALIAN MONITOR TX6000

#AUTX6000  
**\$229<sup>95</sup>**

The TX6000 is a straight-forward, 6-channel single space mic/line mixer



featuring 6 XLR mic inputs and dual RCA inputs per channel. It features a mono tape and headphone output, global bass and treble controls, a balanced XLR output with dedicated master level, individual channel level, and global bass and treble controls. Channel muting is available via optional TX3010 or TX3014 cards.

- Ideal for mono club/restaurant PA's and paging systems
- (6) XLR mic inputs with dual RCA line-level inputs per channel
- 7-segment LED displays master output level
- Phantom power provided on all mic inputs
- Master output on single XLR connection only
- Powered via AC or 24VDC

**MX81** 8-channel mono mixer #AUMX81 ..... **\$417.00**

## AUSTRALIAN MONITOR TX8202

#AUTX8202  
**\$540<sup>00</sup>**



The TX8202 is an 8-channel, 1RU rack mount stereo mixer with

direct outputs. The unit is equipped with 4 balanced switchable mic/line channels and 4 stereo auxiliary inputs, and each input channel offers bass, treble, and pan controls. The first 4 channels offer direct outputs for connection to an external recorder, mixing console, or amplifier.

- 8-channel rack-mount mixer with direct outputs
- (4) XLR mic/line channels with +15V phantom power
- (4) 1/4" TRS balanced direct outputs
- Recessed pan controls
- Vox Muting for Channels 1 and 2

## SHURE SCM262

#SHSCM262  
**\$229<sup>95</sup>**

The SCM262 is a small but versatile six-input stereo mixer designed to combine common audio sources for restaurants, small clubs, health clubs, and educational presentations easily. Some of its flexible features include: defeatable "ducking," a "jukebox mute," phantom power, and balanced/unbalanced inputs and outputs.



- 6-input stereo mixer with XLR, 1/4" TRS and stereo RCA (phone) inputs
- Balanced and unbalanced outputs on 1/4" TRS and RCA (phone) connectors, respectively
- Switchable ducking on mic channels 1 and 2
- Dedicated controls for each input, master, and (global) bass and treble tone levels
- 12V phantom power
- Sturdy, durable build in a 1/2 rack chassis



## SONY SRP-X100

#SOSRPX100  
**\$625<sup>00</sup>**



The SRP-X100 is an audio mixer designed for educational and business applications. It features a total of 9 stereo and mono input channels with flexible routing to Master, Sub, and Record outputs. When activated, a unique Separate Switch routes mic signals to the Sub output while Line outputs are fed to the Master only. Each input combines extended frequency response and headroom with low-noise performance.

- 12-channel mic/line mixer w/phantom power
- (2) XLR mic inputs w/100Hz high-pass filter, (3) stereo RCA line inputs
- (4) mic/line switchable XLR inputs w/100Hz high-pass filter
- Master XLR outputs switchable to mono
- 30dB headroom on mic inputs
- Selectable voltage switch

## BEHRINGER Eurorack Pro RX1202FX

#BERX1202FX  
**\$199<sup>95</sup>**



The 1202FX is a versatile 12-channel rack-mount mixer designed for use in keyboard rigs,

as a multi-track monitor-mixer, or in fixed audio/visual installations. It features 8 mono channels with low-noise mic preamps, line inputs, inserts, and two stereo line-level channels. The mixer also features 24-bit digital stereo effects with 100 presets, 48V phantom power, and 2-band EQ with clip LED per channel.

- 12-channel, rack-mount mic/line mixer with 24-bit digital effects
- Ideal for keyboard, multimedia and small PA setups
- Channel controls include 60mm faders, Pan, FX, Mon, EQ, and Gain
- 8 channels of high-headroom mic preamps, line inputs, and inserts
- Internal switch-mode power supply

## RDL RU-MX4L

#RDRUMX4L  
**\$286<sup>61</sup>**

The MX4L is an ideal choice for mixing unbalanced and balanced line-level signals. Each of the 4 input channels feature balanced XLR connections and unbalanced phono (RCA) input jacks. The unit provides one balanced output, switchable for mic or line level, and an unbalanced Line Output and Direct Input. The unbalanced Line Output may be chained to another RM-MX4L's Direct Input for additional mixing capabilities. Front-panel LED's show each inputs signal and clip status.



- High-quality 4 x 2 Audio Line Mixer
- Ideal for studio and broadcast use
- Convert balanced signals to unbalanced and vice-versa
- Switchable mic or line-level XLR output
- (4) XLR and (4) RCA (phono) inputs

## BEHRINGER Eurorack Pro RX1602

#BERX1602  
**\$109<sup>99</sup>**

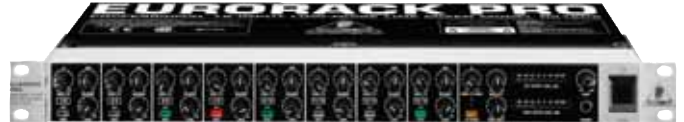

The RX1602 is a multi-purpose, 16-input line-level mixer designed for live or studio keyboard, track monitoring, FX-return sub-mixing, and so on. Each channel features balanced TRS line inputs for individual stereo or mono use, dedicated Balance, Send, and Level controls (+4/-10dB selectable). A double-function LED "mute" switch also provides signal level and clip information.

- 16-input balanced, high-headroom, line-level mixer
- Ideal for multiple keyboard and drum machine setups
- Low-noise design with transparent audio quality
- Dedicated Balance, Level, and Send controls per section
- Global Mon/FX send, dedicated Main left/right output controls

## ART Model 416

#AR416  
**\$129<sup>00</sup>**



Ideal for small musical performances, lounges/bars, and aerobic presentation/instruction, the Model 416 is a 6-channel Personal Mixer that easily combines 6 sources — 3 balanced mic/line inputs and 3 stereo line inputs — into a single stereo line-level mix. It features phantom power on each individual mic channel, allowing the use of condenser microphones, and is capable of patching into external effects processors when necessary. A master 2-band EQ manages overall tonal quality.

- 6-channel Personal Mixer with phantom power and effects send
- Effects loop control with bypass switch
- (3) RCA stereo input channels with separate volume controls
- (3) XLR balanced mic/line inputs with separate volume controls
- 1/4" effect sends with stereo returns

**MODEL418** 8-channel mic/line mixer w/phantom power, XLR and 1/4" inputs, individual direct outs and tone controls per channel #AR418 .....**\$129.00**

## RANE MLM82A

#RAMLM82A  
**\$419<sup>00</sup>**



Ideal for small studio and broadcast setups, the Rane MLM82A is an 8-input Mic/Line mixer featuring 4 XLR mic/line switchable inputs and 4 stereo paired 1/4" TRS phone balanced line inputs. The stereo paired inputs feature mono switches for mono operation and can be routed left/right via assignable A/B channels. The unit provides up to 60dB of gain for microphones with 15V phantom power available for condensers.

- Ideal for small sound reinforcement, DJ mixer mic expansion, commercial installs
- Each individual stereo pair input can be routed mono
- Individual Level/Gain Trim controls and Signal/Overload indicators for each Mic/Line input
- Mix outputs may be padded down to Mic level
- (4) balanced XLR inputs mic/line switchable, (4) TRS stereo pair inputs, XLR outputs

## ROLLS RM64

#RORM64  
**\$209<sup>95</sup>**



The Rolls RM64 is a zone mixer capable of routing 6 inputs of audio to 4 independent areas easily. It features 2 XLR mic inputs that automatically "duck" the (RCA) line level inputs for easy paging. All outputs are on balanced XLR connectors and a 1/4" remote volume jack provides external volume control capabilities. Banquet rooms, DJ rigs, and restaurant/night clubs will appreciate its ease of use and quick setup.

- 6-input channel mixer with (2) XLR mic and (4) stereo RCA line level inputs
- Each input can be routed to any combination of output
- (4) balanced XLR zone outputs
- 12V phantom power
- Front panel level and zone output selection switches
- Recessed DIP switches prevent accidental zone setting changes
- Individual remote volume control jacks

## SYMETRIX Zone Mix 760

#SY760  
**\$1199<sup>00</sup>**



The Zone Mix 760 is a professional 12-in/6-out zone mixer for paging and background music applications in hotels, clubs, restaurants, and convention rooms. It is equipped with four mic/line Euroblock connectors and eight RCA stereo pairs for input of CD, DVD, TV, and other devices and provides six Euroblock outputs. The unit offers built-in compression, feedback elimination, filtering, EQ, AGC, and an Ethernet port for Windows-based computer setup.

- 12-channel/7-zone stereo input/output mixer
- Ideal for hotel, club, and convention installations
- (4) mic/line Euroblock, 8 stereo RCA inputs
- (6) Euroblock outputs, Ethernet connector for PC setup
- Comprehensive internal processing, AGC
- Compatible with Symetrix Adaptive Remote Control wall panels

## SAMSON S-Zone

#SASZONE  
**\$349<sup>00</sup>**



The S-Zone is a 4-channel, single-rack zone mixer featuring 2 balanced mic and 4 balanced

aux/line inputs with a unique front panel control section that allows you to assign any of the four inputs to any of the four zones with just the push of a button. Intuitive user controls consist of front panel input and output volume controls, independent 2-band EQ, and an onboard speaker and headphone jack for selectable zone monitoring.

- 4-channel/4-zone stereo input/output mixer
- Ideal for commercial installs requiring priority ducking with flexible routing capabilities
- Solid, reliable Euroblock connectors
- Independent volume control, stereo/mono switch selector and zone assignment buttons
- Remote volume control
- On-board speaker and headphone monitoring

## ALLEN&HEATH GR2

#ALGR2  
**\$1099<sup>00</sup>**



The GR2 is a 9-in/4-out dual-zone mixer for paging, presentation, and background music for hotel, restaurant, and boardroom installations. The ergonomically-designed rack mount piece offers easily-accessed level, pad, and trim controls, along with phantom power switching. Equipped with XLR, RCA, and Phoenix input connectors and RCA and Phoenix hard-wire outputs, the flexible unit offers stereo and mono zone outs and independent paging and mic expander inputs.

- 9-channel/dual-zone rack- or desk-mounted installation mixer
- Flexible front-panel controls for customized venue applications
- Independent paging and microphone inputs
- XLR, RCA, and Phoenix input connectors
- Stereo and mono zone outputs, dedicated Aux out

## CROWN Commercial Audio Series Pre-Amp/Mixers



The Commercial Audio Series pre-amplifier/mixers are designed for use in a wide range of commercial applications including schools, hospitals, factories, restaurant/retail, fitness facilities, A/V boardrooms, and small offices. Any input can be routed to any output and easily configured for paging, security, background music, evacuation instructions and more; these pre-amp/mixers can be combined with other Commercial Audio Series amplifiers and mixer-amplifiers.

- Ideal for commercial and industrial use
- Balanced Phoenix-style mic/line input/output
- Built-in four-tone generator
- Multiple priority muting configurations
- RCA signal input, mixer configuration switch

**14M** (4) input (1) output version #CR14M ..... **\$294.00**  
**28M** (8) input (2) output version #CR28M ..... **\$405.00**

**INTER-M**  
**PX-0288**

#INPX0288  
**\$1179<sup>95</sup>**

The PX-0288 from Inter-M is a complex yet easy-to-use audio mixer featuring 8 individual



zones of selectable audio with optional remote controllers. Its 8 inputs offer RCA connectors for audio. The audio can then be selected and shared among the eight zones. An internal speaker allows you to monitor the audio in each zone. It includes an input for a paging microphone. Optional remote stations connect via Cat-5 cable for long cable runs.

- (8) RCA and (1) XLR input, (8) balanced outputs
- Bass and Treble control on each output
- Level control for 8 zones
- Optional wall-mount remotes
- Internally recordable digital voice file

**LM-88A** Program selector, volume control, mic and line inputs with gain control #INLM88A.....**\$135.95**

**PS-88A** Program selector and volume control #INPS88A.....**\$131.95**

**INTER-M**  
**PP-9214**

#INPP9214  
**\$423<sup>95</sup>**

Inter-M's PP-9214 is a 2-zone mixer with 8



mono and 2 stereo inputs. Every input features a gain control knob on the front panel. Each channel has a zone-select button to send its audio to zone 1 or 2. The two master outputs are controlled by faders with an illuminated level display for metering. The first eight channels have both mic and line inputs.

- 2-zone mixer with simple routing
- 3-band EQ on each output
- +20V phantom power
- Main and record outputs
- Priority inputs for chimes

**ROLLS**  
**RM68**

#RORM68  
**\$279<sup>95</sup>**



The RM68 is a versatile 9-input dual-zone mixer designed for restaurants, hotels, schools, churches, even factories. 3 XLR inputs and 6 RCA line-level inputs are available with the first mic input featuring a talk-over function that's activated automatically when a source is present. Each input has its own level control, while the output zones feature their own Bass, Treble, and Master level controls.

- 9-input mic/line mixer with automatic talk-over function
- Mic and Source inputs 1-3 share Volume sliders 1-3
- (2) separate zones with (6) assignable inputs and individual level controls
- (3) XLR balanced mic inputs with 12V phantom power
- RCA and 1/4" stereo inputs

**RM64** 4-zone version w/2 mic inputs, talk-over, 4 balanced XLR outputs, 1/4" Remote Volume Jack #RORM64.....**\$209.95**

**ART**  
**Model 405**

#AR405  
**\$169<sup>00</sup>**



The Model 405 is a 5-zone Distribution Amplifier designed to remotely adjust the volume of multiple powered speakers or amplifiers, individually or in groups. It features 2 balanced stereo source channels that are routed to 5 zones, making it possible to adjust complete system components with just one set of controls. Each of the Zones has its own level control for the selected source and provides Source, Clip, and Mono LED indicators.

- 5-zone Distribution Amp with mono/stereo operation
- Typical applications include clubs, restaurants, offices, and retail establishments
- Each zone channel features source 1 and 2 level controls
- LED indicators show Source selection, Clip, and Mono operation
- All connections made with balanced XLR connectors

**ALLEN & HEATH**  
**GR05**

#ALGR05  
**\$799<sup>00</sup>**



The GR05 is a high-quality, 4-zone mixer designed with a flexible architecture which allows easy custom configurations to suit the installation requirements exactly. Its simple interface, operated easily by a non-technical staff, controls the two microphone and three stereo line inputs from the front panel or remote level controls. Ducking, EQ, and muting can be configured and more I/O may be added utilizing the optional expander system.

- 5-input, 4-zone mixer with ducking
- Front-panel level controls
- Signal present LED's
- Lock Out System for reduced tampering
- (2) balanced XLR mic inputs, (3) stereo level-matching RCA

**AUSTRALIAN MONITOR**  
**ZRM4**

#AUZRM4  
**\$666<sup>95</sup>**

The ZRM4 is a professional zone mixer that features 6 mic/line



switchable XLR and 6 stereo RCA input channels which are routable to any combination of 4 zones. Each input provides level, bass and treble controls, phantom power, and high-pass filters with input one designated as the paging/priority input. Each output has a balanced XLR connector with individual level control.

- Great for restaurants, bars, and commercial/industrial establishments
- Versatile, 4-zone routing mixer
- Input and output LED's provide visual routing and status LED's
- Remote VCA control per output
- (6) XLR and (6) stereo RCA inputs, (4) XLR outputs



## INTER-M PA-935

The PA-935 from Inter-M is a compact powered mixer with microphone, line-level,

and telephone paging port inputs. The controls are simple to operate, and the screw terminal I/O offers flexibility for the installer. Inputs two and three can be switched between mic and line while the main mic input and telephone input feature priority muting capabilities for paging purposes.

- 35 watts of power • Bass and treble EQ controls
- 600-ohm telephone port • Screw terminal mic inputs
- Rack mount kit included



#INPA935  
**\$231<sup>95</sup>**

## INTER-M A-120

The A-120 from Inter-M is a 120-watt amplifier with an integrated microphone

and auxiliary line mixer. Its mono output terminals can be tapped to power either conventional 4-ohm speakers or larger 70/100V systems. The main microphone input features a voice-activated priority muting system for paging over the background music from the auxiliary inputs, a handy feature in a sound installation for a business.

- 120 watts of power • Bass and Treble EQ controls
- Level controls for all 5 inputs • Automatic voice-activated muting
- 2-space rack mount kit included



#INA120  
**\$324<sup>95</sup>**

## INTER-M ACR-120M



#INACR120M  
**\$919<sup>95</sup>**

Inter-M's ACR-120M is a powered mixer, an AM/FM receiver, and a 3-disc CD player all

rolled into one. The mixer offers 3 XLR mic inputs and a single auxiliary input. The main microphone input features voice-activated priority muting with a manual four-tone chime option. It can be wired for 4 ohm or 70V sound systems and includes A and B speaker buttons, making it a versatile center piece for businesses and restaurants.

- 120-watt output power • Bass and treble EQ controls
- A and B speaker zones • Voice-activated paging
- 3-space rack mount kit included

## INTER-M SYS-2240M



#INPA2240M  
**\$1279<sup>95</sup>**

The SYS-2240M from Inter-M is a combination mixer/music player that's ideal for restaurants and businesses. All of the bases are covered with five mic inputs, two auxiliary inputs, a dual cassette deck, and a three disc CD player, both of which fea-

ture continuous-play functionality. When operating in 70V mode it offers ten individually selectable speaker zones. Mic inputs one and two feature voice-activated priority muting.

- 240 watts of power • 7-band graphic EQ • Digital AM/FM tuner
- Four-tone paging chime • 6-space rack mount kit included

## INTER-M PAM-120

The PAM-120 from Inter-M is a 120-watt powered microphone mixer that offers multiple options for select sound modules. Out of the box it's a fully-functional PA system offering 6 XLR mic inputs with phantom power and priority muting for paging functionality, as well as a five-zone speaker selector. Easily-installable modules are available to add an AM/FM tuner, a CD player with repeat, and a cassette deck separately.

- 120 watts of power • 3-band EQ on each channel
- 4-tone announcement chime • Optional Cassette, CD, and Tuner modules
- 3-space rack mount kit included



#INPAM120  
**\$599<sup>95</sup>**

## ROLLS MA2355



#RAMA2355  
**\$287<sup>95</sup>**

The MA2355 is a single-space mixer/amplifier designed for installs that require an efficient way to mix 2 microphones with 3 stereo source inputs. It features 2 XLR mic inputs, 12VDC phantom power, Source and Mic tone controls, and Priority Ducking on Mic channel 1 and Source 3. Its amplifier delivers 35 watts of power into 8 ohms and features a fault-protected output with clip indication LED.

- 5-input, 35-watt mixer/amplifier with Priority talk-over
- Single-space, convection-cooled design for small installation applications
- Independent level and output controls with inserts on each output channel
- Stereo pre-Master record output • (2) XLR mic inputs, (3) stereo (RCA) line inputs, spring-loaded terminal outputs

**MA1705** mono version for driving 70V systems #ROMA1705.. **\$287.95**

**PAM-T** AM/FM digital tuner module with 30 memory presets .... **\$135.95**

**PAM-CDA** CD player module with repeat functionality..... **\$383.95**

**CROWN**

**Commercial Audio Series Mixer/Amplifiers**

These high-quality mixer/amplifiers provide 4-ohm and constant-voltage outputs (70/100V). Inputs can be sent to any outputs and are protected with advanced output current limiting, DC protection, circuit breaker/fuse, and thermal protection. Sound systems can be upgraded easily if the facility expands. General applications include schools, houses of worship, fitness facilities, restaurant/retail, and small offices.

- Ideal for commercial and industrial use
- Provides 4-ohm and constant-voltage outputs for 70/100V outputs
- Blue signal, green presence, and red clip LED indicators, Master Output control
- Balanced Phoenix-style and dual RCA inputs/ch., touch-proofed screw-terminal speaker outputs



<b>140MPA</b> 4 x 1 w/40-watts per channel, Music-on-Hold, Paging input, VOX threshold #CR140MPA.....	<b>\$299.99</b>
<b>180MA</b> 4-input 80-watt version #CR180MA.....	<b>\$415.00</b>
<b>280MA</b> 8-input dual 80-watt version #CR280MA.....	<b>\$600.00</b>
<b>1160MA</b> 4-input 160-watt version of 180MA #CR1160MA.....	<b>\$532.00</b>
<b>180A</b> 80-watt amplifier-only version #CR180A.....	<b>\$310.00</b>
<b>280A</b> 2 x 2 80-watt amplifier-only version #CR280A.....	<b>\$445.00</b>
<b>1160A</b> 80-watt dual, 160-watt mono amplifier-only version #CR1160A.....	<b>\$432.00</b>

**CROWN**

**XM-Radio Mixer-Amplifier**



The Crown 180MAX PACK is ideal for adding a professional business music system to your place of business. Simple and affordable, the 180Max PACK integrates an XM Radio tuner and quality 4-input, 80-watt mixer-amplifier into one unit. The XM tuner receives satellite radio stations with digital sound quality and utilizes the front-panel LCD screen to display channel data (channel number, name, artist, and song title), 16 station presets, and signal strength.

- Cost-effective, easy-to-use professional business music system
- XM-Radio satellite tuner with 4 JBL Professional Control 15T 2-way speakers
- Ideal for offices, warehouses, restaurants, bars, and retail stores
- Built-in priority muting when microphone is being used
- Accepts mic/line and telephone signals (phantom power included)
- Balanced Phoenix-style mic/line inputs and touch-proofed screw-terminal speaker outputs

**180MAX** same as above without JBL Control speakers #CR180MAX. **\$499.00**

#CR180MAXPACK  
**\$699<sup>00</sup>**

**ATLAS SOUND**

**CP700**



The CP700 is a 2-channel professional contractor power amplifier with 240-watts per side at 8 Ohms and a built-in 70.7V transformer output-

ting 350-watts per side. The unit features independent power supplies for maximized channel separation, soft-clip limiting, and rear-mounted stepped attenuators. The amp works equally well in applications ranging from clubs and restaurants to paging and foreground music systems.

- 2-channel power amplifier with 70V transformer
- Stereo, bridge and parallel operating modes
- Short-circuit, thermal and DC-offset protection
- Toroidal output transformers for extended HF response
- (2) XLR and barrier strip balanced inputs
- (2) XLR loop-through and (2) spade lug output connectors

#ATCP700  
**\$554<sup>95</sup>**

**SONY**

**SRP-X500P**

The SRP-X500P is a Digital A/V Powered Mixer that provides a cost-effective solution for integrating seven major



presentation devices into one easily configurable unit. An RGB/video switcher, audio mixer, wireless tuner slots, power amplifier, feedback reducer, and EQ are instantly accessible from the front-panel layout, delivering high-quality A/V presentations while eliminating complicated operations and difficult installation procedures.

- 24-bit/48k 4-channel digital powered A/V mixer
- (4) XLR mic, (6) stereo RCA, (3) composite, (2) component inputs
- (4) RCA, (1) composite, (1) component, (2) screw terminal, (2) 70V screw terminal outputs
- Low (280-watt) and high (240-watt 70V) impedance modes
- 2 optional wireless tuner units selectable from Sony UWP-X or WRU-806A/806B Series
- Windows-based management software included

#SOSRPX500P  
**\$1500<sup>00</sup>**

**SONY**

**SRP-X700P**

The SRP-X700P is a feature-laden, six-in-one digital audio and video switcher/router/amplifier capable of handling modern



presentation sources such as PC graphics, wireless/wired microphones, DVD playback, and surround-sound audio. The supplied PC applications, X700P Manager and User Control Panel provide control of audio routing and processing tools, video machine control and routing, and up to two Sony WRU-806 wireless tuner units, integrating a high-quality wireless system into the presentation system.

- 200 watts total power
- Ideal for conference rooms, lecture theaters and other presentation applications
- Accepts (3) RGB/component, composite and S-video inputs
- Selects (1) RGB/component, composite and S-video output
- (6) mic inputs w/phantom power, (2) wireless inputs and line inputs
- Feedback reducer, EQ, compressor/limiter and automatic mixing and routing

#SOSRPX700P  
**\$2495<sup>00</sup>**

**TOA ELECTRONICS**

**900 Series**

The 900 series from Toa is an extremely flexible mixer/amplifier system capable of accomplishing an array of audio tasks in a background music/paging sound system. The mixer itself is simple. The front panel has eight volume knobs, a master volume knob, and a switch to turn off the bass and treble controls. The rear of the unit has eight empty slots that allow you to choose from over 50 plug-in modules to satisfy the demands of your particular system. Your needs will be met whether you need a standard microphone input, additional line level outputs, or a buzzer/yelp tone generator. The speaker output screw terminals are also flexible, allowing the option of 4-ohm, 8-ohm, 25V, or 70V operation.

- Use any combination of plug-in modules to customize a system
- Individual channel, master output and EQ controls, and a low cut filter
- Thermal protection circuitry protects the unit from damage
- Powering-up delay cuts the outputs and protects speakers
- Rear-panel AC outlet to power another piece of equipment
- Five year warranty, optional rack-mount kit available



- TOA903MK2**  
30-watt version .....**\$457.50**
- TOA906MK2**  
60-watt version .....**\$637.50**
- TOA912MK2**  
120-watt version .....**\$766.50**

**ELECTRO VOICE**

**MA-1206**



#ELMA1206  
**\$369<sup>95</sup>**

The MA-1206 is a 60-watt mixer/amplifier with 12 inputs and a telephone paging port. Screw termi-

nals are available for 25V, 70V, and 100V distribution systems, as well as 4-ohm loads. Inputs 1 – 10 feature XLR combo connectors and can be switched from line level to mic level with 24V of phantom power. A line level output completes the unit, making it easily expandable and ideal for professional background music/paging systems.

- 60 watts of power
- Bass and treble EQ controls
- 2 Auxiliary inputs
- Telephone paging input terminal
- Rack mount or tabletop

**MA-1212** 120-watt version #ELMA1212.....**\$495.00**

**ELECTRO VOICE**

**MA-606**



#ELMA606  
**\$309<sup>95</sup>**

The MA-606 is a 6-input mixer/amplifier with 60 watts of power. Four of the inputs can be switched from

mic to line, and two aux inputs are available for background music. Cost-effective and reliable, the MA-606 is designed for smaller 25V, 70V, and 100V distributed sound systems. It features a paging input that mutes all other sound sources, a useful feature in a sound installation for a business or a church.

- 60 watts of power
- Bass and Treble EQ controls
- Level controls for all 6 inputs
- Telephone paging input
- Automatic muting circuit with threshold adjustment

**TOA ELECTRONICS**

**A-9060DH**

The modular A-9060DH Digital Matrix Mixer/Amplifier combines



#TOA9060DH  
**\$973<sup>50</sup>**

a 60-watt amplifier, modular matrix mixer, and powerful digital signal processor into one compact unit. Its design makes it ideal for multi-zone paging, music distribution, and room-combining applications. Combine modules to perform both simple and complex mixing/zone-paging applications with additional DSP.

- Modular mixer/amplifier with 60 watts @ 25/70V, 4/8 ohm and line level
- Built-in DSP with 10-band parametric EQ, compressor and 8-level ducking
- Telephone zone paging, automatic mic mixing, and ambient noise control

- D001T** dual mic/line input w/DSP module #TOD001T .....**\$138.00**
- T001T** dual line output w/DSP module #TOT001T .....**\$109.50**
- ZP001T** telephone zone paging module #TOZP001T.....**\$123.00**
- C001T** I/O control #TOC001T.....**\$91.50**

**TOA ELECTRONICS**

**A-706**

The A-706 is 9-channel, 60-watt mixer/amplifier for paging and background music



#TOA706  
**\$597<sup>00</sup>**

in schools, restaurants, lounges, and other similar venues. It features 6 mic/line inputs with mic trim control and 23VDC phantom power, 2 aux inputs, and one 900-series module slot for accommodating the input module of your choice. It has outputs for 25-70V and 4 ohm systems. Auto-mute provides voice-activated priority muting, selectable via rear-panel switches.

- Customizable 9-channel, 60-watt mixer/amplifier
  - High-quality design and build with customizable inputs
  - Overheating and short-circuiting protection
  - Balanced Phoenix I/O, RCA pre-amp, and record output
- A-712** 120-watt version #TOA712 .....**\$676.50**
  - A-724** 240-watt version #TOA724 .....**\$907.50**



**AUSTRALIAN MONITOR**

**AMIS120P**

#AUAMIS120P  
**\$402<sup>00</sup>**

The AMIS120P is a versatile 120-watt power amplifier with 100V, 70V, and 4- and 8-ohm isolated transformer outputs on barrier strip connectors. Designed for install applications, it is equipped with a balanced line level XLR input (with a parallel output to feed additional power amps), screwdriver accessible gain control on the rear panel, and a front-panel signal indicator LED.



- (1) balanced line level XLR input
- Power Output: 120 watts
- 100V, 70V, and 4- and 8-ohm isolated transformer outputs
- Amplifier may operate from mains power or 24V DC
- Rear panel recessed gain control
- Current limiter protection
- 26.45 lbs

**AMIS250P** 250-watt version #AUAMIS250P..... **\$717.00**

**TOA**

**BG SERIES**



The BG Series Mixer/Amplifiers are ideal for a wide variety of installed sound applications such as paging, music distribution, and messaging on-hold. This series features two models, BG-115 (15-watts) and BG-130 (30-watts), each with one paging input for microphone or telephone and two auxiliary

inputs for music or other line-level sources. Accessories include optional rack and wall-mount kits and volume control security knobs to protect settings.

- Small and lightweight housing that can be desk- or rack-mounted
- MIC/TEL page & Program inputs (screw terminal)
- Dual RCA Auxiliary inputs
- 25/70V & 4-ohm speaker outputs(screw terminal)
- Auto-Mute/External mute functions
- Music-On-Hold output
- Bass/Treble tone controls
- Rear panel AC convenience outlet

**BG-115** 15-watt version #TOBG115.. **\$208.50**    **BG-130** 30-watt version #TOBG130.. **\$243.00**

**TOA**

**P-912 MK2**

#TOP912MK2  
**\$655<sup>50</sup>**

The P-912 MK2 is a modular single-channel power amplifier designed for paging,



background/foreground music distribution and music/message-on-hold applications. A single module slot allows you to arrange custom configurations easily using TOA plug-in modules with an extensive array of features and connector types. This amplifier's outputs include transformer-isolated 25V, 70V, and 8-ohm plus a direct low-impedance mode if non-transformer operation is required.

- Modular Single Channel 120-watt Power Amplifier
- 25V, 70V, and 8-ohm speaker outputs
- Single expansion slot for TOA plug-in modules
- Master Volume control & low-cut switch
- Volume control security knob included
- Rear-panel AC convenience outlet

**P-906 MK2** 60-watt version #TOP906MK2..... **\$541.50**  
**P-924 MK2** 240-watt version #TOP924MK2 ..... **\$1140.00**

**CROWN**

**180MA**

#CR180MA  
**\$415<sup>00</sup>**



The 180MA is a versatile single channel 80-watt amplifier designed for commercial and industrial installation applications. These high-value amplifiers provide both 4-ohm and 70V/100V outputs on touch-protected screw terminal connectors. The 180MA is equipped with balanced Phoenix-type connectors for input, preamp line out, and VCA output control.

- Ideal for background music, paging, and security applications
- Power output: 80 watts
- Balanced Phoenix-type inputs
- Touch-protected screw terminal speaker outputs
- Detented master volume control
- Auxiliary 24VDC power input
- LED clip and presence indicators
- Includes: Detachable rack ears, Phoenix-type connectors, spade lugs
- 26.0 lbs

**1160MA** 160-watt version #CR1160MA ..... **\$532.00**

**CROWN**

**280MA**

#CR280MA  
**\$600<sup>00</sup>**



The 280MA is a dual-channel, 80-watt amplifier designed for two-zone background music, paging and security applications. This affordable installation amplifier provides two channels of both 4-ohm and 70V/100V outputs on touch-protected screw terminal connectors. The 280MA is equipped with balanced Phoenix-type connectors for inputs, preamp line outs and VCA output control.

- Ideal for commercial and industrial applications
- Power output: 80 watts
- (2) balanced Phoenix-type inputs
- Touch-protected screw terminal speaker outputs
- (2) detented master volume controls
- Auxiliary 24VDC power input
- LED clip and presence indicators (per channel)
- Includes: Detachable rack ears, Phoenix-type connectors, spade lugs
- 30.3 lbs

**AUSTRALIAN MONITOR  
AMIS120**

#AUAMIS120  
**\$543<sup>50</sup>**



The AMIS120P is a 4-channel, 120-watt mixer/amplifier with four universal input channels (with separate level controls), and 100V, 70V, and 4- and 8-ohm isolated transformer outputs. It features a six-position speaker zone selector, a built-in, four-tone generator, and VOX muting.

- (4) XLR mic inputs, (4) stereo RCA auxiliary inputs
- Power Output: 120 watts RMS
- Phantom power on all mic inputs
- 100V, 70V, and 4- and 8-ohm isolated transformer outputs
- 6-position, push-button speaker zone selector
- Built-in, 4-tone generator module
- Insert point on rear panel
- Amplifier may operate from mains power or 24V DC.
- 26.45 lbs

**AUSTRALIAN MONITOR  
AMIS250**

#AUAMIS250  
**\$840<sup>00</sup>**



The Amis250 is a 6-channel, 250-watt mixer/amplifier with six universal input channels (with separate level controls), and 100V, 70V, and 4- and 8-ohm isolated transformer outputs. It features a three-band EQ (Bass, Middle and High), a built-in four-tone generator, and VOX muting.

- (6) XLR mic inputs, (6) stereo RCA auxiliary inputs
- Power Output: 250 watts RMS
- Phantom power on all mic inputs
- 100V, 70V, and 4- and 8-ohm isolated transformer outputs • 3-band EQ
- Built-in 4-tone generator module
- Insert point on rear panel
- Amplifier may operate from mains power or 24V DC.
- 33 lbs

**AUSTRALIAN MONITOR  
AMIS60**

#AUAMIS60  
**\$450<sup>00</sup>**



The AMIS60 is a comprehensive 4-channel, 60-watt mixer/amplifier designed to drive 70V or 8-ohm audio systems in restaurants, commercial retail, and institutional installs. It features 4 universal input mic/line channels with both XLR and dual (RCA) connectors, a telephone input jack for paging, and insert point for external processing. A six-position, push-button speaker zone selector with over-riding "all call" is located on the front panel. Each of the six zone selectors, switch the 70V speaker line output to 6 separate speaker zones. An announcement Tone Generator, VOX muting, phantom power, and circuit protection are standard.

- 4-channel, 60-watt mixer/amplifier with (4) XLR and (4) dual RCA inputs
- 70V and 8-ohm output including a balanced 700mV XLR output for feeding up to 6 amplifiers
- Six front panel zone selector buttons • Built-in four tone announcement generator
- Current limiting for overload and overdrive conditions • Master Bass and Treble EQ control

**TOA  
BG-1060**

#TOBG1060  
**\$517<sup>50</sup>**



The BG-1060 is a 5-channel, 160-watt mixer/amplifier designed for background/foreground music distribution, paging and music/messaging-on-hold. It offers three inputs: Microphone/Telephone(selectable), program (pgm), and auxiliary (aux). Speaker outputs include 25V/75V and 4 ohm on screw terminal connectors (with protective cover).

Speaker outputs include 25V/75V and 4 ohm on screw terminal connectors (with protective cover).

- Microphone input (w/phantom power) on balanced screw terminals • Power output 60-watts
- Switchable 600/10k-ohm telephone input • Auxiliary inputs on dual-RCA connectors
- 25V, 70V, and 4-ohm speaker outputs • Voice-activated auto-mute function • Bass/Treble tone controls • 900 series modular expansion port • Optional rack mount kit • 14.11 lbs

- BG-1015** 15-watt version #TOBG1015.....**\$255.00**
- BG-1030** 30-watt version #TOBG1030.....**\$366.00**
- BG-1120** 120-watt version #TOBG1120.....**\$565.50**

**TOA  
DA Series DA-250FH**

#TODA250FH  
**\$1329<sup>00</sup>**



The DA Series amplifiers are digital multi-channel amplifiers designed for multi-zone distributed speaker systems and professional sound applications. They operate more efficiently than typical amplifiers, consume less energy—producing less heat—and are compact and lightweight. Each channel is provided with its own power supply and precise gain calibration attenuator for superior reliability and performance throughout the life of the unit.

- High impedance version 4 x 250-watts (70V), 2 x 500-watts bridged (140V)
- Built-in Limiter and high-pass filter • Extremely efficient Class D design with low energy use and heat output • Compact single rack-space design
- Electronically balanced inputs, terminal screw outputs

- DA250F** low impedance version of above 250W/ch. 4-ohms, 170W/ch. 8-ohms #TODA250F.....**\$1329.00**

**QSC**  
**ISA Series**

The ISA Series ("Ti" versions) are versatile power amplifiers



designed for distributed audio system systems. These 3 RU amplifiers provide isolated 25, 70, and 100V outputs, XLR & Euroblock inputs, and barrier strip outputs. The ISA Series amplifiers are a cost-effective power solution for any permanently installed sound system.

- 25, 70, 100V, and low-impedance outputs available simultaneously
- Simple barrier strip output connection
- Selectable high-pass filters
- Independent defeatable clip limiters
- Front-panel indicators include power, signal, and clip
- Automatic variable-speed fan
- ISA300Ti 44 lbs., ISA500Ti 49 lbs., ISA800Ti 57 lbs

<b>ISA300Ti</b>	300 watts(70V) 200 watts(25V)	#QSISA300Ti.....	<b>\$509.00</b>
<b>ISA500Ti</b>	500 watts(70V) 300 watts(25V)	#QSISA500Ti.....	<b>\$599.00</b>
<b>ISA800Ti</b>	800 watts(70V) 500 watts(25V)	#QSISA800Ti.....	<b>\$759.00</b>

**ROLLS**  
**MA1705**



#ROMA1705  
**\$287<sup>95</sup>**

The MA1705 is a 70V mixer/amplifier designed for installation applications. The single rack space unit provides a compact and efficient way to mix up to three audio sources with up to two microphones. Priority talk-over (ducking) is provided on microphone one for paging, and on source three for a jukebox, telephone, etc.

- (2) XLR microphone inputs with phantom power
- Power output 70-watts
- Tone controls for each microphone input
- Three stereo Source inputs (mixed to mono)
- Drives 70V speakers directly
- Priority ducking on Mic Two and Source One
- Fault protected power amp
- Balanced 70V line output
- Spring-loaded output terminals
- 5.5 lbs.

**ROLLS**  
**MA2152**

The MA2152 is a flexible 2-space mixer/amplifier that can be used with 4-, 8-, or



#ROMA2152  
**\$434<sup>95</sup>**

16-ohm speakers or 70V systems without the need for additional transformers. It provides two XLR Microphone inputs, three sets of stereo RCA inputs and 1/4" output options including full stereo, mono 70V, and dual mono 25V.

- (2) XLR microphone inputs with phantom power
- Power output: 70 Watts RMS per channel @ 8-ohms
- Tone controls for each microphone input
- Three stereo RCA Source inputs
- Drives 25V or 75V lines directly
- Priority ducking on Mic One and Source Three
- Bass and Treble controls on Sources One and Two
- Stereo pre-master level Record output
- Fault protected power amp
- 12 lbs

**ROLLS**  
**RA170**

#RORA170  
**\$187<sup>50</sup>**



The RA170 is a single-space mono amplifier designed especially for the installation contractor. It is equipped with both RCA and 1/4" unbalanced inputs, and 70V speaker outputs are provided via spring-loaded terminals (no transformer is required for speaker connection). The output circuitry is protected from momentary shorting and excessive load by a specially designed protection circuit.

- Balanced 70V line output
- Power output: 70 watts
- Mono RCA or 1/4" unbalanced input
- Spring-loaded output terminals
- Front panel: Power indicator LED, volume control, and 2 Clip LED's
- Fault-protected output
- No transformer required for speaker connection
- 5.5 lbs

**AUSTRALIAN MONITOR**  
**AMIS120XL**

#AUAMIS120XL  
**\$675<sup>00</sup>**



The Amis120XL is an 8-channel, 120 watt mixer/amplifier with eight universal input channels (with separate level controls), and 100-volt, 70-volt and 4- and 8-ohm isolated transformer outputs. It features a built-in, four-tone generator module, a three-band EQ (bass, middle, and high), and multiple levels of VOX muting.

- (8) XLR mic inputs, (8) stereo RCA auxiliary inputs
- Power Output: 120 watts RMS
- Phantom power on all mic inputs
- 100V, 70V and 4- and 8-ohm isolated transformer outputs
- External VCA control
- Built-in, 4-tone generator module
- Insert point on rear panel
- Amplifier may operate from mains power or 24V DC.
- 26.45 lbs



## RANE MA4

#RAMA4  
**\$1099<sup>00</sup>**



The MA4 is a 4-channel, 100-watt (per channel) amplifier designed for installation applications like music & paging systems and small conference rooms. This space-saving unit is only 1U and weighs only 8 lbs. Its advanced dynamics control algorithms adapt to changes in temperature, load impedance, and sensitivity setting, ensuring signal integrity at all times. The optional MT 4 multichannel transformer is available for 70V/100V distribution.

- (4) balanced inputs on Euroblock connectors
- (4) Euroblock output connectors
- Power Output: 100 watts x 4
- Optional 4-channel 70V/100V transformers in 1U chassis (MT 4)
- Adjustable high-pass filters and remote level controllable
- Remote fault reporting and redundancy switching
- 8 lbs

**MT4** optional 4-channel 70V/100V transformer  
#RAMT4 ..... **\$289.95**

## INTER-M QD4240

#INQD4240  
**\$503<sup>95</sup>**



The QD4240 is a four-channel power amplifier that's capable of operating in stereo, dual mono, and bridged mono modes. Each channel has an individual volume control knob and warning lights for peak and signal protection. The inputs are XLR and 1/4" combo jacks, and speaker wire connects via rugged five-way binding posts. Soft-start protection circuitry will prolong the life of your sound system, making it ideal for businesses, churches, and restaurants.

- 4-ohm quad 40 watts/ch, 8-ohm quad 60 watts/ch, 8-ohm bridged mono 120 watts
- Power, signal, protection, and clip indication lights
- Stereo, bridged, and parallel operation modes
- Front-panel handles and internal cooling fans
- 2RU rack space enclosure

## INTER-M PA-935

#INPA935  
**\$231<sup>95</sup>**



The PA-935 is a compact, 3-channel desktop mixer powered by an internal 35-watt, 70V amplifier, designed for music and paging use with fixed-speaker installations in professional, commercial, or school offices. The unit is equipped with three 1/4" microphone inputs and two 1/4" auxiliary line inputs for stereo playback devices, and features additional telephone inputs for music-on-hold and paging requirements.

- Self-powered, 3-channel music/paging mixer
- 35-watt, 70V amplifier for fixed-installation speaker setups
- 1/4" and telephone connectors
- Variable output impedance
- Large easy-access volume/gain and bass/treble tone controls

## INTER-M PA-2000

#INPA2000  
**\$495<sup>95</sup>**



The PA-2000 is a 60-watt integrated mixer/amplifier designed for install applications. It provides six input channels (with adjustable

input sensitivity from mic to aux Level), a five-band graphic EQ, a four-note chime, five speaker selector switches, a telephone paging input, and priority muting. The PA-2000 can be configured for 4-ohm/8-ohm or 25V/70V/100V output.

- (5) balanced screw-terminal inputs and dual RCA inputs
- Output power: 60 watts
- Mono 4/8-ohm or 25V/70V/100V output
- Priority muting via external contact or voice activation
- Built-in 5-band EQ
- 4-note chime and siren button
- 5-zone speaker selector switches
- Optional input connector plates: XLR, 1/4" phone or RCA
- 24.3 lbs

**PA-4000** 120-watt version #INPA4000 ..... **\$519.95**

## INTER-M A-120

#INA120  
**\$324<sup>95</sup>**



The A-120 is a 120-watt public address amplifier designed for basic install applications such as restaurants, classrooms, retail stores, and small offices. It provides three balanced microphone inputs, two auxiliary inputs and mono 4-ohm or 70V/100V output. Priority Vox muting is available on the Mic 1 input; overriding music for paging.

- Versatile and easy to use
- (3) XLR-1/4" TRS combo mic inputs (no phantom power), (2) auxiliary inputs
- Output power: 120 watts
- Mono 4-ohm or 70V/100V outputs
- Level controls for Mic 1, 2 & 3, Aux 1 & 2, Master
- Bass and Treble Controls
- Voice-activated priority muting
- 2 rack space (rack mount kit included)
- 27.6 lbs.

**A-60** 60-watt version #INA60 ..... **\$284.95**

## INTER-M PA-2312

#INPA2312  
**\$531<sup>95</sup>**

The PA-2312 from Inter-M is a 120-watt amplifier for 70/100V distributed audio systems. There are 2 female XLR inputs and 2 male XLR outputs to pass the audio to additional amplifiers; a high-pass filter to protect speakers and a ground lift switch to prevent hum. Dual level control knobs in front with an LED display with signal and protective circuitry indicators.

- Power output: 120 watts
- Automatic thermal protection circuitry
- 2-speed cooling fan
- 3 rack space
- 24VDC power connection for field use



## INTER-M PA-9348

#INPA9348  
**\$798<sup>50</sup>**

The PA-9348 is a heavy-duty, single-channel, 480-watt power amplifier. It features a balanced XLR input with adjustable gain from -12dB to 0dB and an XLR output link for using additional amplifiers. Complete circuit and component protection is provided through automatic thermal circuit protection, a two-speed cooling fan, and a switchable high-pass filter.

- Single-channel, 480-watts @ 4-ohms 70V
- "Idling" circuitry protects against thermal runaway
- Front panel LED's indicate output level of -40dB, -10dB, clipping, and circuit protection
- Ground-lift isolation switch
- 24VDC capable powering

## INTER-M PM-9208

#INPM9208  
**\$255<sup>95</sup>**

The PM-9208 from Inter-M provides visual and audible monitoring of the amplifier or speaker line signals of up to 8 separate 70/100V audio feeds. It features a 10-segment LED meter for each input and an internal speaker. The passive speaker gets its power from the distributed audio system or amplifier, while the LED meters require separate 24VDC power.



- 5-step attenuation to match different amplifier levels
- Built-in monitor speaker
- Channel selection and attenuation switches
- Screw terminal inputs
- Requires 24VDC power

## ROLLS RA2100b

#RORA2100B  
**\$288<sup>95</sup>**



The RA2100b is an inexpensive 200-watt installation amplifier built to drive 4- or 8-ohm speakers and 25-70V systems. It's built ruggedly, and its convection-cooled steel chassis includes special transformers, a fused power line, and a fault-protected MOSFET output stage, protecting against occasional power fluctuations. Additional features include RCA inputs, LED power meters, and a one second turn-on delay, protecting against transient spikes.

- 200-watt stereo/mono amplifier capable of 25-70V line operation
- Intuitive, easy setup and usage
- MOSFET drivers in a voltage and current gain circuit
- Convection-cooled for reduced operating noise
- Front-panel volume control and LED power meters
- Dual (RCA) inputs, 1/4" and banana-style output

## ATLAS SOUND AA120

#ATAA120  
**\$349<sup>00</sup>**



The AA120 is a powerful 120-watt mixer/amplifier designed with unique features for today's commercial business audio environments. This 6-input unit provides extensive muting and output options along with a very unique bridge in/out feature, allowing multiple amplifiers to be combined without the need for external relays. VCA control is included and may be assigned to the BGM input or for the entire amplifier.

- 6-input, 120-watt mixer/amplifier
- Bridge in/out circuit with balanced link for small room combining systems
- Special low-cut filter bypasses front-panel bass control to allow for paging horns
- Remote or Vox mute capabilities, music-on-hold, background music and paging
- (5) mic inputs, stereo Aux input, tape/dual-line and pre-outs (Phoenix and RCA connectors)

**SYMETRIX****371 SPL Computer**#SY371  
**\$499<sup>00</sup>**

The 371 SPL Computer is ideal for commercial and retail applications where sound system audio levels need to raise or lower automatically in response to changes in ambient noise conditions. It's designed for foreground music and paging, ensuring that music and announcements are clearly audible, but not too loud. Simply step through the LCD menu guide, set the acoustic environment parameters and then set the response characteristics.



- Proprietary AmbiSense responds to environmental noise changes
- External mic measures noise changes
- 3 operational modes (Active, History, Bypass)
- Adjustable SPL vs. program level ratio
- Gain and Ducker controls
- Control mono or stereo signals through Euroblock connectors

**SYMETRIX****322 DSP Engine**#SY322  
**\$599<sup>00</sup>**

The 322 DSP Engine is a 24-bit multifunction signal processor designed to provide all the processing generally needed between a mixer and a power amplifier in smaller sound systems. Delays, Compressors, Filters, Parametric EQ's, and more are easily combined utilizing a simple drag-and-drop application editor within the 322 Designer control software, increasing system flexibility and overall performance.

- 2-in 2-out 24-bit multifunction DSP signal processor
- Provides the processing of multiple units in a single tamper-proof rack
- Controlled via RS232 port and Symetrix 322 Designer software (PC)
- Easy drag-and drop-setup of processing blocks with 4 user presets
- Filters, Dynamics, EQ, Crossover, Mix & Send, Speaker Alignment, and Signal Generator
- Euroblock I/O

**BOGEN COMMUNICATIONS****GS250**#BOGS250  
**\$882<sup>95</sup>**

The GS250 is a 250-watt amplified mixer designed for use with public address installation systems. The deluxe unit comes with an internal 10-band graphic equalizer, an Apex Aural Exciter for improved speech intelligibility, and 4 dedicated XLR inputs with individual gain controls. The mixer also includes a telephone input with voice-activated muting.



- 250-watt powered mixer with 4 XLR inputs
- (2) switchable mic/aux or mic/telephone inputs
- Tape outputs
- Individual gain controls for all inputs
- Bal/unbal 8 Ohms, 25V, 25VCT, 70V, and 4 Ohm direct output impedances

**ASHLY****SRA Series**

The SRA Series are efficient, convection-cooled amplifiers that provide superior sound quality and little maintenance after install. Each utilizes a switch-mode power supply and Class-D circuitry, providing a compact, lightweight and modest powering solution. Its rear panel features Euroblock inputs, screw terminal outputs, and selectable switches for input sensitivity, high-pass filter, and normal or bridged mode operation.

- Ultra-quiet, convection-cooled amplifiers with switchable power supplies
- Front-panel level attenuators, signal present and clip LED's
- Extensive protection circuitry
- Euroblock inputs/screw terminal outputs
- Remote power turn-on/off and adjustable turn-on delay up to 8 seconds

**SRA4075** 4-channel, 75-watt/channel @ 4-ohm #ASSRA4075.....**\$630.00**  
**SRA4150** 4-channel, 150-watt/channel @ 4-ohm #ASSRA4150.....**\$715.00**

**ASHLY****TRA-Series**

The TRA Series are convection-cooled amplifiers that combine great sound, efficient performance, simultaneous low impedance and transformer-coupled 70/100V output. Every TRA amplifier utilizes a switch-mode power supply, Class-D circuitry, and provides a compact, lightweight powering solution needing little or no maintenance. Its rear panel features Euroblock inputs, level controls, screw terminal outputs, and selectable switches for input sensitivity, high-pass filter, and normal or bridged mode operation.

- Simultaneous low impedance and transformer coupled 70/100V output
- Ultra-quiet, convection-cooled amplifiers with switchable power supplies
- 6-segment signal level LED's for each channel
- Extensive protection circuitry
- Euroblock inputs/screw terminal outputs

**TRA4075** 4-channel, 75-watt/channel @ 4-ohm #ASTRA4075.....**\$830.00**  
**TRA4150** 4-channel, 150-watt/channel @ 4-ohm #ASTRA4150.....**\$900.00**



**DBX**

**ZonePro 640**

The ZonePro 640 is an advanced 6 x 4 Digital Zone Processor that features flexible signal routing, powerful DSP processing and multiple control interfaces for Commercial Audio applications. Ideal for a variety of commercial applications, the 640 provides not only the necessary processing tools for high-quality audio, but an intuitive Routing module for Primary Source Selection and Source Ducking for Paging and Priority Override.



- 6 input 4 output 24-bit/48kHz Digital Zone Processor
- DSP includes: Compression, Limiting, Feedback Suppression, Gating, Filtering, EQ, and Autowarmth
- Wall Panel Control, programmable Real Time Clock, RS-232 control
- ZonePro designer software included for system setup and monitoring
- Euroblock (mic/line) and RCA (source) inputs, Euroblock outputs

<b>ZONEPRO641</b> same as above w/tamper-proof front panel #DBZP641 .....	<b>\$849.95</b>
<b>ZONEPRO1260</b> 12 x 6 version w/Ethernet control and wider dynamic range #DBZP1260.....	<b>\$1349.95</b>
<b>ZONEPRO1261</b> tamper-proof version of 1260 #DBZP1261 .....	<b>\$1149.95</b>

**ACCESSORIES**

- |  |   |   |  |  |   |
|--|---|---|--|--|---|
| <p><b>ZC1</b><br/>programmable volume zone controller for user-selected volume range<br/>#DBZC1 ..... <b>\$59.95</b></p> | <p><b>ZC2</b><br/>programmable vol. &amp; mute zone controller for volume range and zone muting<br/>#DBZC2 ..... <b>\$59.95</b></p> | <p><b>ZC3</b><br/>panel switch for changing Programs, Scenes, Sources or Mic Page Assignments<br/>#DBZC3 ..... <b>\$69.95</b></p> | <p><b>ZC4</b><br/>changes Programs, Scenes, Sources, or Mic Page Assignments from up to 4 contact-closure switches<br/>#DBZC4 ..... <b>\$74.95</b></p> | <p><b>ZCBOB</b><br/>breakout box allows parallel or "home run" wiring of zone controllers<br/>#DBZCBOB .. <b>\$89.95</b></p> | <p><b>ZCFIRE</b><br/>an interface to Fire Safety systems<br/>#DBZCFIRE.. <b>\$74.95</b></p> |
|--|---|---|--|--|---|



**LECTROSONICS**

**DM1624**

#LEDM1624  
**\$3548<sup>95</sup>**



The DM1624 is a powerful 16 x 24 digital audio processing, mixing, routing management system. Its primary application is for sound reinforcement, boardrooms, houses of worship, hotels, and other applications with multiple microphones and loudspeakers. Any of the 16 mic/line inputs can be routed to any or all 24 outputs, passing through multiple DSP filters, an automatic digital feedback eliminator, compressor and digital delay. Gain is adjustable from -69 to +20dB in 1dB steps at each crosspoint.

- (16) mic/line inputs, (24) line outputs (8 outputs are mic/line switchable (5-pin Phoenix))
- 6 filter stages plus compressor, feedback eliminator and delay on each input
- 9 filter stages plus compressor, limiter, and delay on each output
- USB and RS-232 interfaces for setup, LecNet2 control software included
- Digital I/O (RJ45) for "daisy chaining" multiple units

<b>DM1612</b> 16-in/12-out version #LEDM1612.....	<b>\$2893.95</b>
<b>DM812</b> 8-in/12-out version #LEDM812.....	<b>\$2078.50</b>

**LECTROSONICS**

**DM84**

#LEDM84  
**\$1799<sup>95</sup>**



The DM84 is a Digital Matrix Processor that offers an 8-in/4-out mic/line digital matrix architecture in a stackable configuration. Loaded with features, the DM84 provides extensive signal and control capabilities for any sound system with multiple microphones and loudspeakers. The full compliment of filters, feedback eliminators, compressors, limiters, and delays are available on every channel input and output, each of which has its own front-panel level control with activity LED's.

- 8-in/4-out automatic matrix mixer (5-pin Phoenix I/O)
- Ideal for houses of worship, conference rooms, hotels, courtrooms
- Extensive control capability built-in with intuitive command structure
- 6 filter stages plus compressor, feedback eliminator and delay on each input
- 9 filter stages plus compressor, limiter, and delay on each output
- USB and RS-232 interfaces for setup, LecNet2 control software included

**EAW**

**DX Series**

#EADX810  
**\$1749<sup>00</sup>**



Designed for a variety of installations such as houses of worship, hotels, multi-zone paging/music systems, and convention centers, the powerful DX810 is a versatile DSP-based digital audio mixer and signal processor that provides powerful control of all system functions. The supplied software easily configures control groups with instant recall of all parameters including compression, delay, crossover points, and EQ. Its inputs are optimized to provide an extended dynamic range for both mic and line levels.

- 8 x 10 Digital Matrix Mixer w/32-bit DSP and 24-bit A/D
- True Room combining (up to 16 combinations)
- Inputs feature: Level/Peak metering, Gating, Compressor, 2-band High/Low EQ w/parametric Mid
- Outputs feature: Level/Peak metering, 31-band Graphic/8-band Parametric EQ, Compressor, Delay
- Balanced I/O on Phoenix-style connectors

<b>DXRVC</b> assignable remote volume control for any gain point #EADXRVC.....	<b>\$59.95</b>
<b>DXSW4</b> assignable remote switch control for I/O muting and preset recall #EADXSW4 .....	<b>\$59.95</b>

## ASHLY 4.24D

#AS4.24D  
**\$1155<sup>00</sup>**



The 4.24D combines a flexible 4 x 8 distribution amplifier and powerful audio processing capabilities into a single-spaced unit with all balanced Euroblock I/O. Each input has gain controls, high/low shelf filters, 6-band parametric EQ, and can be assigned to any output. Each output sets the crossover frequencies, has a programmable 4-band parametric EQ, high/low shelf filters, output gain, and a compressor/limiter for speaker protection. Programming is simple; connect to a Windows PC and utilize the included system software for your own configuration.

- 4 x 8 Audio Distribution Processor
- Inputs can be assigned to any output and utilize built-in DSP
- Crossover, EQ, delay and limiter functions
- LED indicators for signal and clip/limiter
- Euroblock connectors with 80-260V operation

## ATI AUDIO DA 1008-1

#ATDA10081  
**\$1149<sup>95</sup>**



The DA 1008-1 is a professional 1-in/8-out distribution amplifier designed to provide up to 26dB of balanced output, free of hum and RF interference. Its higher output, low-noise performance is capable of driving longer lines, eliminating frequency rolloff and distortion from mismatched load impedances. The unit provides an input clipping LED and level LED meter with three selectable 0VU settings, allowing you to set nominal line levels and monitor peak headroom.

- 1 x 8 distribution amplifier with 26dB of gain
- Professional-quality audio for audio/video installations • Front-panel headphone jack, metering or auxiliary ninth output
- Actively balanced outputs with LED output clipping indicator • Superior RF and hum protection with full short circuit isolation
- Reliable barrier block connectors for easy servicing

## APHEX 120A

#AP120A  
**\$279<sup>00</sup>**



The 120A by Apex is an easy-to-operate distribution amplifier that

effectively routes a single input to four outputs. Connections are made via servo-balanced XLR connectors, and its simple control panel provides individual output level controls and a signal/clip LED indicator. The wide frequency response of the unit helps maintain the audio performance quality with little or no noise or coloration.

- Ideal for any application requiring transparent routing of audio signals
- 1 x 4 distribution amplifier with individual level control
- Compact, rugged half-rack design allows both portability and convenience
- Wide dynamic range and frequency response with maximum gain before noise level
- Servo-balanced XLR input and outputs

## SYMETRIX 581E Distribution Amplifier

#SY581E  
**\$499<sup>00</sup>**



The 581E is a very flexible distribution amplifier with 4 balanced inputs and 16 balanced outputs. The one input, four output sections are independent of each other, but can be combined to accommodate stereo sources or route a single mono source to all 16 outputs. A 4-LED level meter on each input assists in setting up ideal input and output operating levels, each of which can be controlled individually.

- Ideal for Broadcast, Installed Sound, and Post Production
- Very low noise, high-performance audio distribution amplifier
- Flexible 4-input, 16-output routing capabilities
- All inputs and outputs on balanced detachable terminal blocks
- Input and output level individually controlled

## INTER-M PO-9106

#INPO9106  
**\$319<sup>95</sup>**



The PO-9106 from Inter-M features a single line-level XLR input and 6 line-level XLR outputs, giving you the ability to distribute a single audio signal to multiple balanced outputs. The front panel features independent level controls and peak warning lights for each channel. Inter-M has included a 24VDC battery connection for remote field use.

- Transformer-isolated balanced XLR outputs
- Electronically balanced XLR input • Level control on every channel
- LED peak lights • Occupies a single rack space

**AUSTRALIAN MONITOR****AMIS26**#AUAMIS26  
**\$309<sup>95</sup>**

The AMIS26 is a 2-input, 6-output low-noise distribution amplifier that provides both balanced and unbalanced operation with selectable sensitivity for the inputs and outputs. Each input can be routed to any individual output via front-panel DIP switches and displays its signal strength using 4 segment LED meters, an ideal affordable solution for a wide range of installation needs.

- 2 x 6 distribution amplifier with adjustable sensitivity selection
- Input levels can be cut or boosted up to 15dB
- Output levels can be attenuated up to 60dB
- Inputs and outputs made via XLR or RCA connectors
- Inputs and outputs can operate either balanced or unbalanced
- Switchable 24V phantom power per input

**ROLLS****RA 63S**#RORA63S  
**\$149<sup>95</sup>**

The RA 63 is an inexpensive 1-in, 6-out distribution amplifier featuring a straightforward design with balanced screw terminal type connections on both the inputs and outputs. Output levels for channels 1-6 are on the front panel and are accessible via screwdriver controls, reducing tampering of channel levels. 12V terminals are provided for low-voltage amplifiers, and an additional 20dB of gain is provided to the output from a front panel switch.

- 1 x 6 distribution amplifier with balanced screw terminal connections
- Recessed screw-type level controls reduce tampering
- 12V terminals allow for use in commercial settings with low voltage amplifiers
- 20dB output gain switch on front panel

**WHIRLWIND****DA-2**#WHDA2  
**\$415<sup>95</sup>**

The DA-2 is a high-quality distribution amplifier capable of switching between a mono 1 x 8 or stereo 2 x 4 configuration.

It features individual level controls and LED indicators for each output, a dedicated master volume control, and headphone output. All inputs and outputs are on balanced XLR connectors and provide high-output, high-headroom audio for professional installs.

- 1 x 8 mono or 2 x 4 stereo distribution amplifier
- All inputs and outputs on electronically-balanced XLR connectors
- Red clip and green signal present LED indicators
- Rugged, durable build quality, ideal for mobile or install use
- Headphone output with dedicated level control • 22dB of headroom

**RANE****DA-216S**#RADA216S  
**\$415<sup>00</sup>**

The DA-216S is a 2-in/16-out distribution amplifier for music and paging applications in multi-zone fixed installations. The sleek, flexible rack-mount unit is outfitted with 3-pin terminal blocks for all inputs and outputs, and each input offers mic/line switching and selectable phantom power. The outputs may be assigned to either or both input signals, and zones can be set up as music or paging only, or both.

- Multi-zone distribution amplifier for music and paging
- 3-pin removable terminal blocks for all I/O's
- Overload LED's and 15V phantom power for inputs
- Screwdriver controls for all I/O's prevent unauthorized level changes
- Universal power supply for worldwide use
- Simultaneous 600-Ohm load drive for all outputs

**RANE****DA26**#RADA26  
**\$459<sup>00</sup>**

The DA26 is an all-in-one solution for mixing, amplifying, and routing audio to multiple outputs. It features a balanced line input with Automatic Gain Control, a priority mic/line paging input with an adjustable threshold/ducker amount, and 6 balanced outputs, all on Euroblock connectors. The balanced outputs provide loudness compensation and distribute full-range, high or low-pass program music.

- 1 x 6 distribution amplifier with dynamics and crossover control
- Mic/line priority paging and balanced line level inputs
- Adjustable ducker range and automatic gating threshold
- Automatic Gain Control handles audio levels and dynamics
- Remote control of zone levels without affecting paging level



**ELECTRO VOICE**

**EVID 3.2**

The EVID 3.2 is a passive surface mount installation speaker system featuring dual 3.5" woofers and a 0.75" tweeter capable of handling 150 watts of power. Its durable ABS enclosure includes a zinc-coated grille for internal component protection, and weather-resistant treated woofers with a symmetrically located tweeter. The speakers are full range and attach easily to a variety of locations via the (SAM) Strong-Arm-Mount, allowing for a high degree of horizontal and vertical directivity.

- Dual 3.5" woofers with 150 watts of power
- Well-suited for home theater and post-house monitoring
- Unique cabinet design • Cast aluminum mount (SAM)
- 85Hz–20kHz frequency response • 3.3 lbs (each)

**EVID E3.2T** transformer isolated version for 70V/100V use  
 #ELE32T ..... **\$200.00** pair  
**EVID 3.2TW** white transformer isolated version of EVID 3.2  
 #ELE32TW ..... **\$200.00** pair

#ELE32  
**\$200.00** pair



**ELECTRO VOICE**

**EVID 6.2**

The EVID 6.2 is a passive surface mount installation speaker system featuring dual 6" woofers and a 1" titanium tweeter capable of handling 300 watts of power. These full-range speakers perform like much larger speakers, feature a durable, weather-resistant ABS enclosure, and attach easily to a variety of locations via the (SAM) Strong-Arm-Mount, allowing for a high degree of horizontal and vertical directivity.

- Dual 6" woofers with 300-watts of power
- Ideal for larger areas such as airports, stadiums, shopping malls
- Titanium tweeter with efficient Neodymium magnet and waveguide control • Cast-aluminum mount (SAM)
- 62Hz–20kHz frequency response • 12 lbs (each)

**EVID 6.2T** transformer isolated version of above  
 #ELE62T ..... **\$490.00** pair  
**EVID 6.2TW** white transformer isolated version of above  
 #ELE62TW ..... **\$490.00** pair

#ELE62  
**\$490.00** pair



**ELECTRO VOICE**

**EVID 4.2**

The EVID 4.2 is a passive surface mount installation speaker system featuring dual 4" woofers and a 1" titanium tweeter capable of handling 200 watts of power. The speakers are full range and attach easily to a variety of locations via the (SAM) Strong-Arm-Mount, allowing for a high degree of horizontal and vertical directivity; ideal for restaurants, bars, and bistros.

- Dual 4" woofers with 200 watts of power
- Unique cabinet design
- Superior control of mids and highs
- Cast-aluminum mount (SAM)
- 65Hz–20kHz frequency response • 8.5 lbs (each)

**EVID 4.2T** transformer isolated version of above  
 #ELE42T ..... **\$290.00** pair  
**EVID 4.2TW** white transformer isolated version of EVID 4.2  
 #ELE42TW ..... **\$290.00** pair

#ELE42  
**\$270.00** pair



**ELECTRO VOICE**

**EVID 12.1**

The EVID 12.1 is a passive 12" subwoofer capable of handling up to 350 watts of power. It is designed to be ceiling or wall mounted, preferably in a corner, and features four speaker outputs for stereo pairing or independent satellite speakers. Ideal for restaurants, bars and meeting/event facilities, the EVID 12.1 provides the low bass performance for which Electro-Voice has been known for years.

- Unique 12" dual voice coil accepts Left/Right stereo low end sources
- 175 watts per voice coil, 350 watts total
- Wall or ceiling mounted
- Built-in passive stereo crossover
- 40Hz–140Hz frequency response
- 40 lbs.

**EVID 12.1W** white version of the above  
 #ELE121W ..... **\$380.00**

#ELE121  
**\$380.00**



**ELECTRO VOICE**

**EVID 12.1P**

The EVID 12.1P is a professional 300-watt powered subwoofer featuring an efficient 12" speaker that produces smooth, deep bass down to 42Hz. Although capable of being used in multiple configurations, the 12.1P is optimized for integration with Electro-Voice EVID Series installation loudspeakers and can be mounted easily into corners or suspended via supplied bracket hardware.

- Powered 300-watt 12" subwoofer
- Full-range line-level output and high-pass output on back panel
- Side/Front angled design improves low frequency dispersion
- Variable active 12dB/octave crossover
- XLR I/O • 42Hz–160Hz frequency response
- 49 lbs.

**EVID 12.1PW** white version of the above  
 #ELE121PW ..... **\$639.00**

#ELE121P  
**\$639.00**



**JBL**  
**Control 1 Pro**

The Control 1 Pro is a professional loudspeaker system ideal for both professional and residential applications. Its rugged polypropylene enclosure houses a 5" woofer and a 0.75" dome tweeter with standard spring-loaded speaker terminals on the rear. The cabinet is magnetically shielded for safe use near video monitors, making it a great choice for video editing suites and post-production facilities.

- 150-watt power handling
- Compact two-way speaker system
- SonicGuard protection circuitry to prevent overloads
- 5" woofer and 0.75" tweeter
- 80Hz-20kHz frequency response
- Ball and socket mounting bracket included for versatile positioning
- 4 lbs (each)



#JBC1PROB  
**\$154.95** pair



**JBL**  
**Control 5**

Designed to reproduce audio accurately for a variety of applications, the Control 5 is a passive monitor with a 6.5" woofer and 1" titanium tweeter. Its 175-watt power handling provides sufficient capability to be used effectively for audio/video post, broadcast, and even restaurant and bar installs. Optional hardware allows the magnetically-shielded cabinet to be mounted easily on walls near video monitors without fear of interference.

#JBC5B  
**\$423.50** pair

- 175-watt power handling with a 6.5" woofer and 1" tweeter
- Internal circuit protection
- Optional mounting hardware
- 75Hz-20kHz frequency response
- 10 lbs. (each)

**Control 5W** white version of above  
#JBC5W.....**\$413.50** pair

**JBL**  
**Control 23**

Capable of handling 50 watts of power from its 3.5" woofer and 0.5" tweeter, the Control 23 is the smallest monitor of JBL's Professional Control Contractor Series. Perfectly suited for subtle indoor/outdoor foreground, background, and music paging applications, the Control 23 features weather-resistant components and a unique InvisiBall mounting design, providing superior vertical and horizontal coverage, even in harsh environmental conditions.

#JBC23B  
**\$169.95** pair

- 50-watt power handling with a 3.5" woofer and 0.5" tweeter
- Secure adjustable mounting system
- WeatherEdge provides added protection from outdoor elements
- 85Hz-22kHz frequency response
- 4 lbs (each)

**Control 23W** white version of above  
#JBC23W.....**\$169.95** pair  
**Control 23TB** transformer isolated version of above  
#JBC23TB.....**\$194.95** pair



**JBL**  
**Control 25**



Designed for both indoor and outdoor applications, the rugged, weather-resistant Control 25 is an extremely versatile speaker capable of handling 150 watts of power from its 5.25" woofer and .75" titanium tweeter. Mounting, security, and coverage adjustments are easily made via InvisiBall mounting hardware. Ideal for theme parks, health clubs, small bars, and restaurants.

#JBC25B  
**\$239.50** pair

- 150-watt power handling with a 5.25" woofer and 0.75" titanium tweeter
- Excellent vertical and horizontal coverage adjustability
- WeatherEdge provides added protection from outdoor elements
- Overload protection circuitry
- 80Hz-16kHz frequency response
- 5 lbs (each)

**Control 25W** white version of above #JBC25W.....**\$239.95** pair  
**Control 25TB** transformer isolated version of Control 25  
#JBC25TB.....**\$259.95** pair

**JBL**  
**Control 25AV**



Designed with the same professional features as the Control 25 including WeatherEdge weather resistance and InvisiBall mounting hardware, the AV adds video shielding, a 60-watt transformer, and increased power coverage and frequency response for use in small clubs, restaurants, and post-production audio/video facilities.

#JBC25AVB  
**\$299.95** pair

- 200-watt power handling with a 5.25" woofer and 0.75" tweeter
- 60-watt transformer for 70V/100V use
- Shielded for use near video monitors
- Sonicguard overload protection
- 70Hz-23kHz frequency response
- 9 lbs (each)

**Control 25AV-WH** white version of above  
#JBC25AVWH.....**\$298.50** pair

**JBL****Control 28**

The versatile Control 28 features an 8" woofer and 1" titanium tweeter capable of handling 175 watts of power. Its InvisiBall mounting and WeatherEdge harsh element protection allow the Control 28 to be used both indoors and out, making it especially well suited for restaurants and clubs with outdoor decks/patios, amusement parks, and health clubs.

- 175-watt power handling with an 8" woofer and 1" tweeter
- WeatherGuard weather-resistant enclosure
- Secure InvisiBall mounting system • SonicGuard overload protection
- 60Hz–16kHz frequency response • 12 lbs (each)

**Control 28T60B** multi-tap transformer version for 70V/100V use  
#JBC28T60B.....**\$409.95** pair

**Control 28T60W** same as above in white  
#JBC28T60W.....**\$409.95** pair



#JBC28B  
**\$382.95** pair

**JBL****Control 29AV**

The Control 29AV is a video-shielded, 300-watt professional indoor/outdoor monitor designed to provide smooth, high-fidelity audio with increased dynamic range and output coverage. Its rotatable 110° x 85° horn allows for either vertical or horizontal mounting. Combining higher output, InvisiBall mounting, WeatherGuard element protection, and SonicGuard circuit protection, the Control 29AV is ideal for midsize venues in any environment.

- 300-watt power handling with an 8" woofer and 1" compression driver
- Computer-optimized cabinet and horn design with wide dispersion and high output
- Supports both vertical and horizontal mounting
- Ideal for indoor/outdoor use • 40Hz–19kHz frequency response
- 27 lbs (each)

**Control 29AV1W** same as above in white  
#JBC29AV1W.....**\$304.95** each



#JBC29AV1B  
**\$274.95** each

**JBL****Control 30**

The Control 30 is a three-way, high-output speaker featuring a rugged, molded, high-impact polystyrene shell that is perfect for a wide variety of applications. Weather resistance has been maximized, making it suitable for both indoor and outdoor placements, and the 10" Fiberglass/Kevlar woofer will stand up to the most demanding installations. It features a top-quality 150-watt multitap transformer for 70V/100V line distribution systems with a bypass for use as an 8-ohm speaker.

- 500-watt power handling with 10" woofer
- Includes JBL Invisible Mounting Kit
- 1" tweeter with Titanium diaphragm • 5" symmetrical mid-high frequency horn
- 38Hz–17kHz frequency response

**Control 30-WH** white version of above #JBC30W.....**\$591.95** each



#JBC30B  
**\$591.95** each

**TOA****F-10**

The F-10 is a unique surface mount speaker that features a triangle cabinet design that easily mounts into corners of a room, blending seamlessly into its environment. Its 4" full-range woofer can handle up to 45 watts of continuous power, and is sealed in an acoustically-dampened, airtight enclosure. Great for institutional paging systems, background music in restaurants, or surround satellites.

- 45-watt power handling from its 4" woofer
- Wide range of mounting choices
- Optional transformer
- 100Hz–18kHz frequency response
- 3.3 lbs (each)

**F-10W** white version of above  
#TOF10W.....**\$133.50** each



#TOF10B  
**\$133.50** each

**TOA****F-160**

The F-160 is a surface mount foreground/background speaker designed to provide maximum efficiency with a flat frequency response. It can be mounted either vertically or horizontally with optional brackets and provides up to 150 watts of continuous power from its 5" woofer and 1" tweeter. All internal components are protected by a rigid polypropylene enclosure with circuit protection, ideal for restaurants, bars, and institutional applications.

- 150-watt power handling from its 5" woofer and 1" dome tweeter • Flat response when mounted in half-space environments (corners)
- Vertical or horizontal mountable
- Internal circuit protection
- 100Hz–20kHz frequency response • 7.3 lbs (each)

**F-160W** white version of above  
#TOF160W.....**\$130.50** each  
**F-160GM** isolated transformer version for 70V/100V use #TOF160GM.....**\$156.00** each



#TOF160G  
**\$130.50** each



**TOA**  
**F-240**

#TOF240G  
**\$199.50**  
each

Similar in design to the F-160, the F-240 surface mount speaker features a larger 6.25" woofer and 1" titanium dome tweeter with a constant directivity horn. The larger woofer handles the same 150 watts of continuous power, but it provides an overall wider frequency range. Its titanium dome tweeter also gives the added advantage of a smoother high-frequency response.

- 150-watt power handling from its 6.25" woofer and 1" titanium tweeter
- Optional vertical or horizontal mounting
- Rigid polypropylene enclosure
- Internal circuit protection • 65Hz–20kHz frequency response • 10.8 lbs (each)



**F-240W** white version of above  
#TOF240W ..... **\$199.50** each  
**F-240GM** isolated transformer version  
for 70V/100V use #TOF240GM ..... **\$213.00** each

**TOA**  
**HB-1**

#TOHB1  
**\$352.50**



The HB-1 is a flush-mount, 240-watt passive subwoofer designed to enhance low frequencies in commercial, residential, and retail sound systems. It features a heavy-duty 8" woofer in a tuned port enclosure that acts as its own heat sink, and a bandpass filter design eliminating the need for an external crossover. It is ceiling or wall-mountable and also features a paintable grille and optional matching transformer for connecting to a distributed speaker system.

- 240-watt power handling from its 8" woofer
- Adds smooth bass extension to a variety of speaker systems
- Bandpass design eliminates external crossover
- Ceiling or wall-mounting capability
- Solid, vibration-free steel enclosure with paintable grill
- 45Hz–200Hz frequency response

**TOA**  
**F-160GM**

#TOF160GM  
**\$156.00**

The F-160GM is a 2-way surface mount installation speaker suitable for paging and background music applications. The bass-reflex polypropylene enclosure houses a 5" cone woofer and a 1" dome tweeter for a smooth, wide frequency response, along with a built-in 70.7/100V transformer providing multiple taps up to 30 watts. The speaker may be horizontally or vertically mounted.

- Up to 30-watt power handling capacity
- Multi-tap 70.7/100V transformer
- Vertical or horizontal mounting
- Internal overload protection circuitry
- 100Hz–20kHz frequency response
- 8.6 lbs (each)



**F-160WM** white version of above  
#TOF160WM ..... **\$156.00**

**GALAXY AUDIO**

**Chameleon Micro Spot PM-B**

#GAMSPMB  
**\$79.99**  
each

The Chameleon Micro Spot was originally designed for courtroom applications, yet is ideal for fixed installation applications such as paging systems and boardrooms. Standard features include a universal wall/ceiling bracket and a 70-volt transformer with 6 adjustable taps of .9w, 1.8w, 3.7w, 7.5w, 15w, 30w, and a 16-ohm position. The 16-ohm position is a transformer bypass that allows the user to step around the transformer and use the Chameleon Micro Spot as a 100-watt speaker.



- 100-watt power handling
- NEOLITE Neodymium 5" driver
- Mounts to any wall, ceiling, table or other surface
- Black case with cloth-covered ABS grill
- 150Hz–18kHz frequency response

**Galaxy Audio Chameleon Micro Spot PM-W** white version of above #GAMSPMW ..... **\$79.99** each

**TOA ELECTRONICS**  
**H1**

#TOH1  
**\$99.95**

The H1 is a passive 2-way installation speaker designed as an attractive alternative to the standard mounting-speaker "box" presentation. The molded curves of the unit minimize sound reflection and present a subtle, sensuous appearance, appealing to architects and interior designers wishing to match functionality with ambience. The speaker is loaded with three woofers and a soft-dome tweeter, and sports a steel and ABS resin enclosure.



- Attractive, molded interior design speaker
- (3) 2" woofers, 1" Balanced-dome tweeter
- 120Hz–20kHz frequency response • 85dB SPL
- Rotating speaker design for optimal coverage
- Built-in overload protection
- Mounting hardware included

## TOA F-505

The F-505 is a passive 240-watt bass-reflex speaker system that's designed for both mobile and permanent install applications. It delivers a smooth extended frequency response and uniform 60° x 40° dispersion pattern from its 8" woofer and constant directivity horn. The F-505 is built from a low-foam polypropylene enclosure that ensures improved acoustic characteristics and durability, while the built-in circuit protection guards against overloads.

- 240-watt power handling from its 8" woofer and horn driver
- Ideal for small PA and recorded music playback in restaurants, lounges and institutions • 1/4" phone jacks may be converted to XLR
- Constant directivity horn delivers well-controlled coverage
- 70Hz–20kHz frequency response • 16.5 lbs (each)

**F-505W** white version of above #TOF505W.....**\$673.50**  
**F-605G** 360-watt version with 12" woofer (grey) #TOF605G..**\$1128.00**



#TOF505G  
**\$673<sup>50</sup>**

## TOA BS1030

The TOA 1030's are 90-watt paging/background speakers designed for both indoor and outdoor applications. They can be mounted easily, vertically or horizontally, and are enclosed in an ABS resin cabinet with steel mesh grille for added weather resistance. Ideal for a variety of applications, the 1030's feature a multi-tap transformer for use in environments such as audio/visual facilities, retail stores, institutions, and indoor/outdoor restaurant music/paging systems.

- 90-watt power handling capability from its 4.75" woofer and 1" dome tweeter
- Multi-tap transformer for 70V/100V use
- Bass-reflex design for extended frequency response and volume
- Simple vertical or horizontal mounting
- Paintable ABS weather-resistant enclosure
- 80Hz–20kHz frequency response • 5.5 lbs (each)

**BS1030W** white version of above #TOBS1030W.....**\$114.00**



#TOBS1030B  
**\$114<sup>00</sup>**



## ELECTRO-VOICE ZX1i-90

The ZX1i-90 is a passive full-range, 2-way indoor/outdoor installation loudspeaker, with a durable all-weather enclosure and water-resistant steel grille, housing an 8" woofer and a 1" compression driver in a rotatable horn. The speaker features a snap-on surface mount and a coverage pattern suitable for long-throw and cluster install applications.

- 200-watt continuous power handling
- 8" woofer, 1" tweeter in 90° x 50° rotatable horn
- Optimized for long-throw and cluster applications
- Integrated snap-in mounting bracket
- Weather-resistant polymer enclosure and 18-gauge steel grille
- 18.5 lbs. (each)

#ELZX1190  
**\$337<sup>50</sup>**

## AZDEN APS 25

The APS 25 is a compact and versatile powered speaker designed for either wired or wireless operation. It provides 20 watts of power to its 5.25" woofer and 1" wide dispersion tweeter, suitable for corporate meetings, educational, and commercial applications. Either one or two UHF/VHF infrared wireless modules may be used, and multiple systems can operate in a single venue without interference.

- Powered wired/wireless speaker system with 20 watts of power
- VHF (169-213MHz) 30 fixed frequencies
- UHF (794-806MHz) 63 user-selectable frequencies
- 1/4" mic level input, unbalanced RCA line level input/output jacks
- Master and tone controls
- Speaker may be stand or wall mounted
- 65Hz–18kHz frequency response

#AZAPS25  
**\$159<sup>95</sup>**



## QSC AD-S52

The AD-S52 is a passive full-range surface mount speaker capable of both indoor and outdoor operation. It features a weatherproof 5.25" woofer, 1" neodymium tweeter, and built-in dynamic power protection ensuring its usage in multiple environments including hotels, restaurants, lounges, and multimedia facilities. This great-sounding speaker has a sleek, rugged design that can be mounted flush to the wall or ceiling via the included ball-mount adapter.

- 60-watt power handling from 5.25" woofer and 1" tweeter
- Vented enclosure design for greater volume with extended bass
- Durable, injection-molded enclosure is weather resistant
- Dual 5-way binding power connections
- 60Hz–20kHz frequency response

**AD-S52T** transformer tap version for 70V/100V use #QSADS52TB.....**\$294.00**

#QSADS52B  
**\$256<sup>00</sup>**

**QSC**  
**AD-S82H**

The AD-S82H is a professional, high-output loudspeaker that's ideal for indoor and outdoor environments. It mounts securely and easily thanks to QSC's IntelliDock docking station, combining all the required components, wire, and speaker positioning into a single housing, independent from the enclosure. The AD-S82H's 8" woofer and 1" compression driver deliver an accurate, detailed sound regardless of the mounting configuration.

- 240 watts of power from its 8" woofer and 1" compression driver
- Advanced Directivity Rotatable Waveguide (60° x 90°)
- Full-range power protection circuitry
- Transformer taps for 70V/100V use
- 80Hz–21kHz frequency response

**AD-S82** 110-watt version with smaller voice coil and 1" titanium tweeter #QSADS82B.....**\$159.00** each

#QSADS82HB  
**\$254.60**  
each



**QSC**  
**AD-S282H**

The AD-S282H is a high-powered, full-range permanent install speaker provided with the best features of the Acoustic Design Series: weather-resistant transducers, a rotatable waveguide enclosure for improved accuracy, and versatile mounting options allowing for both vertical and horizontal mounting. Dual 8" woofers and a 1" compression driver deliver 450 watts of continuous power to indoor and outdoor environments.

- 450 watts from dual 8" woofers and 1" compression driver
- Ideal for hotels, restaurant/lounges and convention facilities
- Weather-resistant woofers for both indoor and outdoor use
- Wide 90° x 60° dispersion pattern on either horizontal or vertical axis
- 80Hz–27.7kHz frequency response

**AD-S282HT** built-in transformer for 70V/100V use #QSADS282HTB.....**\$639.00** each

#QSADS282HB  
**\$599.00**  
each

**EAW**  
**SMS3**

The SMS3 is a compact loudspeaker ideal for permanent install business music systems. Its lightweight, weather-resistant enclosure can be installed easily via supplied wall-mount brackets. The SMS3 contains a 4.75" carbon-fiber woofer and 0.5" mylar dome tweeter that produces a smooth, natural tone with impressive coverage for a speaker of its size.

- 60 watts of constant power from 4.75" woofer and 0.5" tweeter
- Built-in transformer for 70V/100V use
- Adjustable rotary switches for wattage, voltage, and 4-ohm operation
- Lightweight, durable UV/weather-resistant enclosure
- 150Hz–20kHz frequency response

**SMS4** 120-watt version with 5" woofer and circuit protection #EASMS4.....**\$135.00**

**SMS5** 175-watt version with 0.75" horn loaded tweeter and banana inputs #EASMS5.....**\$148.00**

#EASMS3  
**\$99.95**



**ATLAS**  
**SM52-B**

The SM52-B is a 2-way, surface-mount speaker designed for use in both indoor and outdoor environments. It's ideal for commercial, professional, and residential installs requiring full-range foreground or background music. Up to 100 watts of continuous power is provided from its 5.25" and 1" dome tweeter. A rugged C-shaped mounting bracket allows for both vertical and horizontal mounting, optimizing audio coverage.

- 100 watts of power from 5.25" woofer and 1" tweeter
- Designed with components to withstand the harshest environments
- High-frequency WaveGuide provides smooth, even coverage
- Internal circuit protection against overload
- 1/4" and 5-way binding post inputs
- 85Hz–20kHz frequency response

**SM52-W** white version of above #ATSM52W.....**\$178.95**

**SM52T-B** 30-watt transformer version for 70V/100V use #ATSM52TB.....**\$212.95**

#ATSM52B  
**\$178.95**



**ATLAS**  
**SM82-B**

The SM82-B is a high-powered, full-range loudspeaker designed to provide superior performance in both indoor and outdoor installations. It combines a highly efficient 8" woofer and 1" titanium driver to provide 150 watts of continuous power. It's designed to install vertically or horizontally with ease, and features weather-treated and tested components capable of withstanding harsh environments.

- 150 watts of continuous power from 8" woofer and 1" tweeter
- Excellent for pool areas, outdoor restaurants, sports clubs and lounges
- High-frequency circuit protection and accurate wave guide coverage
- Easy-to-mount with included C-shape mounting bracket
- 65Hz–20kHz frequency response

**SM82-W** white version of above #ATSM82W.....**\$159.95**

**SM82T-B** 60-watt transformer version for 70V/100V use #ATSM82TB.....**\$194.95**

#ATSM82B  
**\$159.95**





**ELECTRO-VOICE****EVID C4.2**

The EVID C4.2 is a compact ceiling-mount speaker designed to fit into tight areas while delivering a smooth, full-range response. Its 4" woofer and .75" tweeter are housed in an esthetically pleasing steel enclosure that can handle up to 80 watts of power and can operate in 8-ohm or 70V/100V applications. An easy 3-point mounting system and ported design allows easy installs and surprising bass response from such a small package.

- 80-watt handling capacity from 4" woofer and .75" tweeter
- Either 70V/100V or 8 ohm operation are standard
- Ported, steel cabinet design with interior dampening and passive crossover
- Built-in overload protection • 65Hz–20kHz frequency response
- 6 lbs



#ELC42  
**\$164.95**

**ELECTRO-VOICE****EVID C8.2**

The EVID C8.2 is a professional ceiling-mount speaker with a specially-tuned enclosure that delivers high-quality audio with an outstanding bass response and smooth, controlled coverage from its 8" woofer and 1" waveguide coupled tweeter. The design handles 100-watts of power and reproduces frequencies from 50Hz to 20kHz.

- 100 watts of power from 8" woofer and 1" tweeter
- Ideal for more dynamic audio in lounges/bars, restaurants, and retail establishments
- Paintable, dampened steel enclosure with overload protection and built-in crossover
- 70V/100V operation capability
- 4-point flush mounting system • 50Hz–20kHz frequency response
- 11 lbs



#ELC82  
**\$228.95**

**EVID C8.2LP** low-profile version for shorter clearances #ELC82LP... **\$228.95**

**EVID C8.2HC** same as above with "Pattern Control" #ELC82HC.... **\$333.95**

**ELECTRO-VOICE****205 Series**

The 205-8A is an economical 4", full-range speaker designed for improved high-frequency dispersion and intelligibility of speech and program music. It's capable of handling 10 watts of continuous power and mounts on any standard 4" ceiling speaker baffle. Any standard back enclosure with a diameter of 5.5" and depth of at least 4.5" will do; however, a deeper enclosure will increase its low-frequency response.

- 10 watts of continuous power from 4" full-range woofer
- Ideal for paging systems and background music
- Front or rear-mountable against either surface of its mounting flange
- Acoustically transparent dome and center-mounted free edge cone improves intelligibility
- 90Hz–18kHz frequency response • 2.0 lbs

**205-4T** 4-watt transformer tap version of above #EL2054T..... **\$25.95**

**205-8T** 8-watt transformer tap version of above #EL2058T..... **\$29.95**

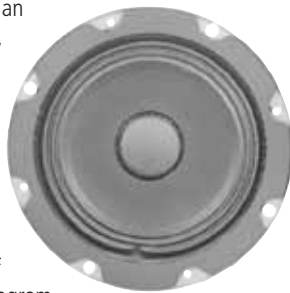

#EL2058A  
**\$19.95**

**ELECTRO-VOICE****309 Series**

The 309-8A is a 2-way, 16-watt ceiling install speaker with an 8" woofer and wide dispersion cone tweeter. Its dual magnet construction allows each speaker to be structurally, magnetically, electrically, and mechanically independent of each other. This allows the components to work together to produce smoother sounding audio as a complete, highly-efficient system.

- 16-watts of continuous power handling from 2-way 8" system
- Great for paging and background music in offices, restaurants, and retail establishments
- Front- or rear-mountable against either surface of its mounting flange
- 85Hz–18kHz frequency response
- 3.3 lbs

**309-4T** 4-watt transformer tap version #EL3094T..... **\$35.95**

**309-4TWB** 4-watt transformer tap version with supplied baffle #EL3094TWB..... **\$49.95**

**309-8T** 8-watt transformer tap version #EL3098T..... **\$39.95**

**309-8TWB** 8-watt transformer taps with supplied baffle #EL3098TWB..... **\$56.95**

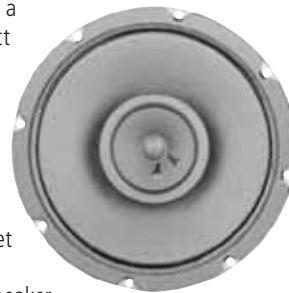

#EL3098A  
**\$29.95**

**ELECTRO-VOICE****405 Series**

The 405-8H is a high performance full-range loudspeaker designed to provide the best possible performance from a speaker this size. Its die-cast aluminum frame and heavy-gauge steel magnetic structure allow the compact 4" speaker to be ceiling or wall mounted and provide 16 watts of clear, intelligible speech and music reproduction.

- 4 watts of continuous power from a full-range 4" speaker
- Higher-quality components for extended life and superior performance
- Front or rear-mountable against either surface of its mounting flange
- Ideal for retail establishments, hospitals, and institutions
- 60Hz–15kHz frequency response
- 2 lbs

**405-4T** 4-watt transformer tap version of above #EL4054T..... **\$53.95**



#EL4058H  
**\$38.95**

**ELECTRO-VOICE**

**409 Series**

The 409-8E is an 8", 2-way loudspeaker system that provides superior performance with high temperature voice-coil assemblies that are coaxially mounted with a wide-dispersion tweeter. The single section crossover network is centered at 2500Hz and allows for 6dB of attenuation of each element outside their normal operating range. The unit's response is smooth, articulated, and delivers ideal characteristics for either background or foreground music.

- 32-watt, 8" speaker system
- Dual magnet structure coaxially mounted
- Front- or rear-mountable against either surface of its mounting flange
- 85Hz–18kHz frequency response
- 2.8 lbs

**409-8T** 8-watt transformer tap version of above #EL4098T..... **\$69.95**

**409-16T** 16-watt transformer tap version of above #EL40916T.. **\$76.95**

**409-32T** 32-watt transformer tap version of above #EL40932T.. **\$65.95**

#EL4098E  
**\$44.95**



**ELECTRO-VOICE**

**EVID C10.1**

The EVID C10.1 is a 10", 150-watt ceiling mount subwoofer designed to augment the low-frequency response of any EVID ceiling speaker. The system utilizes a passive crossover network for correct bandpass frequency response and can operate from 8 ohms to 70V/100V. It's capable of delivering high-output audio with a wide dispersion and includes a tile bridge for use in a wide range of ceiling constructions.

- 150 watts of continuous power from 10" woofer
- Integrated ported enclosure for extended bass response
- ABS baffle and bezel with zinc-plated steel rear enclosure
- Convenient front baffle wattage tap adjustment switch
- Low pass crossover network with overload protection
- 45Hz-180Hz frequency response
- 15.5 lbs

#ELC101  
**\$314.95**



**JBL**

**Control 24C Micro**

The 24C Micro is a self-contained 4.5" 2-way professional ceiling speaker that is ideal for low-to-medium volume paging and background music in restaurants, commercial offices, and retail establishments. It includes an 8-watt multi-tap transformer for additional system expandability, and is easy to install without requiring above-ceiling access. Backcan, grille, support bracket, and tile rails are supplied.

- 30 watts of continuous power from 4.5" woofer and .5" tweeter
- Smooth, full-range frequency response
- Supplied with grille, backcan, and tile rails for quick install
- Similar mid/high frequency voicing for mixing and matching models within zones
- 85Hz–25kHz frequency response
- 3.6 lbs

**Control 24CT** Micro- 8-watt transformer tap version of above #JBC24CTM..... **\$129.95**

**Control 24CT** MicroPlus, high-performance 25-watt transformer tap version #JBC24CTMQ ..... **\$174.95**

#JBC24CM  
**\$119.95**



**JBL**

**Control 24C**

The Control 24C is a professional ceiling-mounted speaker that produces a wide frequency response with low distortion. The 4" woofer and .75" titanium tweeter are housed in a computer-optimized ported enclosure that delivers a warm, full-range sound capable of handling up to 80 watts of continuous power. Its internal components are protected by JBL's non-invasive SonicGuard protection, ensuring long-time system reliability and quality.

- 80-watts continuous power handling from 4" woofer and .75" tweeter
- 16-ohm impedance allows multiple speaker use without constant voltage system
- High sound level capability with 130° coverage
- All installation components included and no ceiling access required
- 80Hz–20kHz frequency response
- 6 lbs

**Control 24CT** 30-watt transformer tap version #JBC24CT..... **\$199.95**

#JBC24C  
**\$184.95**



**JBL**

**Control 26C**

The Control 26C is a premium ceiling-mount loudspeaker for background and foreground music sound systems in upscale hotels, casinos, and restaurants. It features a coaxially-mounted 6.5" woofer and wide-dispersion .75" titanium tweeter capable of handling 150 watts of continuous power. All the required install materials are provided, and as with most Control Series ceiling speakers, ceiling access is not required.

- 150 watts of continuous power from 6.5" woofer and .75" tweeter
- Input connection is conveniently provided on a removable locking connector
- 16-ohm impedance allows multiple speaker use without constant voltage system
- Superior performance for upscale commercial and retail establishments
- 75Hz–20kHz frequency response
- 7.5 lbs

**Control 26CT** 60-watt transformer tap version #JBC26CT ..... **\$264.95**

**Control 26DT** speaker assembly of above, made to fit standard 8" backcans #JBC26DT ..... **\$194.50**

#JBC26C  
**\$232.50**

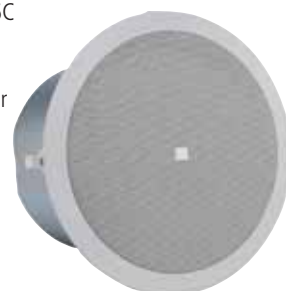

## JBL Control 19CS

#JBC19CS  
**\$348<sup>50</sup>**

The Control 19CS is a powerful 8" ceiling mount subwoofer designed to enhance the fidelity and frequency response of Control Series loudspeakers. This 200-watt subwoofer utilizes proprietary technologies to produce deep bass from its low-profile design. No external crossover or amplifier channel is necessary to run the 19CS in-line with an existing sound system.



- 200-watt power handling capability from 8" woofer
- Unique Nested Chamber design provides high output and natural low pass characteristics
- SonicGuard overload protection
- Linear Dynamics port design produces extended bass output
- 42Hz–200Hz frequency response
- 12 lbs

**Control 19CST** 60-watt transformer tap version #JBC19CST.....**\$379.95**

## TOA F-122CU

#TOF122CU  
**\$126<sup>95</sup>**

The F-122CU is a premium full-range 5" ceiling mount loudspeaker that delivers a powerful 120 watts of continuous power with an impressive 180° dispersion pattern, reducing the overall number of speakers necessary to complete an install. All components feature overload protection and are enclosed in a low-profile metal backcan with paintable grille, ideal for small and medium-sized commercial venues, including airports, museums, and schools.



- 120 watts of continuous power from 5" full-range loudspeaker
- Built-in, 30-watt 25V/70V transformer with 8/16 ohm direct modes
- Convenient front baffle power tap selector switch
- Unique diffuser provides wide, off-axis, high-frequency response
- 70Hz–20kHz frequency response
- Optimized equalization with 900 Series module

## TOA F-2852C

#TOF2852C  
**\$142<sup>50</sup>**

Ideal for high ceiling applications, the powerful F-2852C provides 180 watts of continuous power from its coaxial 6.5" woofer and dome tweeter. Its extended bass response and wide dispersion can be attributed to its particular bass-reflex design and special high frequency diffuser. A built-in, 30-watt transformer allows 70V/100V operation and even direct 8/16 ohm modes, selectable from a convenient front baffle switch.



- 180 watts of continuous power from 6.5" woofer and dome tweeter
- 120° dispersion pattern
- Selectable 8- or 16-ohm operation
- Easy install with 3-point quick-mount system (mounting C-ring included)
- Built-in, 30-watt transformer for 70V/100V operation
- 60Hz–20kHz frequency response

**F-2352C** 5", 120-watt version of above with 170° coverage #TOF2352C .....**\$108.00**

**F-2322C** full-range design version of F-2352C #TOF2322C .....**\$91.50**

## TOA F-1522SC

#TOF1522SC  
**\$57<sup>00</sup>**

The ultra-compact F-1522C ceiling-mount loudspeaker features a 4", full-range driver with a 160° dispersion pattern. It can handle 18 watts of continuous power and provides a 6-watt transformer for 70V/100V operation with 8/16 ohm direct modes. The low-profile design has a paintable grille, four pole push-terminal input connectors, and installs easily via a 3-point quick-mount system.

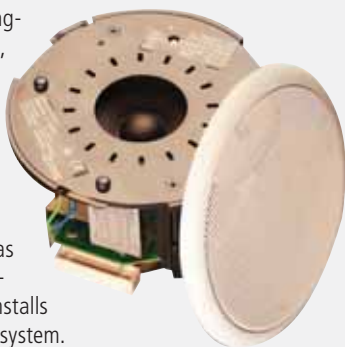

- 18 watts continuous power from 4" full-range speaker
- Extremely compact — just over 4" deep
- Front baffle power tap selector switch
- Dust cover protects components
- Built-in 6-watt 70V/100V transformer with 8/16 ohm direct mode operation
- 65Hz–18kHz frequency response

## TOA PC-3CL

#TOPC3CL  
**\$105<sup>00</sup>**

The PC-3CL is a completely sealed 3.5" splash-resistant speaker designed for high-humidity, high-temperature environments. Its chemical-resistant grille and ABS enclosure make the speaker ideal for clean rooms, hospital operation rooms, bath, and wet sauna rooms. Its power is rated at 3-watts and 1-watt, dependent on the transformer tap used.



- 3 watts of power from 3.5" full-range cone driver
- Completely sealed ABS enclosure with chemical-resistant grille
- Full-range speaker employs a plastic film diaphragm for moisture resistance
- Transformer taps at 1.5 and 0.5W
- Temperature range -4° F to +140° F
- 150Hz–20kHz frequency response



**ATLAS**  
**SD72W**

#ATSD72W  
**\$19<sup>95</sup>**



The SD72W from Atlas is an individually sold dual cone in-ceiling speaker with a white powder coat baffle. It comes with a factory installed 25/70.7 V line matching transformer with tap selections ranging from .25 to 5 watts, making it ideal for paging or background music applications. The baffle has concealed speaker mounting studs and 4 standard mounting holes. It has a treated paper cone for lower harmonic distortion.

- Matches sonic character of the C-Series
- Screw mount hardware included
- 25 watts peak, 15 watts RMS
- Primary Taps (Watts) .25, .5, 1, 2, & 5
- 105° dispersion (2kHz Octave Band, -6dB Points) • 4.7 lb shipping weight, 2 7/8 (Depth) x 8 1/8" (Diameter)
- 45Hz-19kHz frequency response

**SD72WV** With baffle-mounted volume control  
#ATSD72WV ..... **\$19.95**

**TOA ELECTRONICS**  
**PC-671R**



#TOPC671R  
**\$40<sup>50</sup>**

The TOA PC-671R is a 15-watt flush-mount ceiling speaker with an 8" cone driver and an integrated 25/70V transformer. The transformer housing offers a robust steel core that prevents saturation at maximum power. The speaker is only 2.5" in depth, facilitating placement in partitions and other shallow areas, as well as ceilings. The white, gridded speaker also features a corrosion- and contaminant-resistant baffle, and comes with a 5-year warranty.

- 15-watt ceiling mount speaker with flush-mount design
- 8" cone driver, built-in 25/70V transformer
- Built-in 25/70V transformer with steel core
- Corrosion-resistant interior baffle
- Durable ABS resin enclosure
- 90Hz-16kHz frequency response
- 3.5 lbs.

**ATLAS**  
**IS125CS**

#ATIS125CS  
**\$44<sup>95</sup>**

The IS125CS is an all-in-one, pre-assembled drop-in speaker system that saves time and money on installation costs. Each speaker drops easily into the speaker system grid and is made from a perforated metal that blends well with acoustic ceiling tiles. The IS125CS delivers 25-watts of power and operates on 25V/70V systems, ideal for use in institutional applications using large numbers of loudspeakers.



- 25 watts of continuous power
- "Drop-in" speaker system saves install time, reducing labor costs
- Durable, metal grille blends well with acoustic ceiling tiles
- 1' x 2' drop-in ceiling speakers are packaged with two systems per box
- Standard conical backcans included

**IS139CS** 16-watt version of above  
#ATIS139CS ..... **\$69.95**  
**IS149CS** 10-watt version of above  
#ATIS149CS ..... **\$64.95**

**BOGEN COMMUNICATIONS**  
**Metal Box Speaker Series**

The MB8T series are all-steel off-white enclosures with an 8" full range speaker and a built-in adjustable 4 watt multi-tap transformer designed for ceiling or wall mounting. The SL models feature a 12.5° downward angled face, and the VR models include a recessed volume control at the center of the grille. There are tap selection wires corresponding to power settings for both 70V and 25V constant voltage speaker systems.

- Full range 8" speaker cone
- Multiple taps at 4, 2, 1, 1/2, 1/4, 1/8 watts
- Mounting hardware included (toggle bolts, screws, wire crimps)
- 4-Watt maximum output power
- 100° dispersion, 9 lbs
- 110Hz-15kHz frequency response

**MB8TSLVR** Downward angled version with volume control  
#BOMB8TSLVR ..... **\$64.95**  
**MB8TSQ** Non-angled version #BOMB8TSQ ..... **\$44.95**  
**MB8TSQVR** Non-angled version with volume control  
#BOMB8TSQVR ..... **\$64.95**



**ATLAS**  
**FASUB70**

The FASUB70 is a passive, 200-watt, 8" subwoofer designed to enhance the sound fidelity of commercial and retail sound systems. Its tuned, ported enclosure and highly efficient, passive crossover system allow the subwoofer to produce extended low frequencies without dedicated amplification. Installation is made easy with supplied C-ring/V-rail tile bridge and dog leg mounting system.

- 200-watt power handling capability from 8" woofer
- 60-watt transformer tap for 70V systems
- Easy installation in drop tile or sheetrock ceilings via included mounting hardware
- Detachable, Phoenix style four-pole connector for easy daisy chaining
- 45Hz-120Hz frequency response
- 14.5 lbs



**WOHLER TECHNOLOGIES****LM30-2D**#WOLM302D  
**\$694.95**

The LM30-2D is a professional AES/EBU 2-channel Level Metering System. It features 2 large 30-segment tri-colored LED bargraphs, ideal for distance viewing in mobile production vehicles, radio studios, and multimedia facilities. Simultaneous VU (bar) and PPM (dot) bargraph display ballistics.

- Professional 2-channel AES/EBU audio level meter
- (2) large 30-segment tri-colored LED bargraphs
- Adjustable bargraph brightness via front panel control
- Custom variations of standard metering scales

**LM60-2D** 60-segment version of above #WOLM602D..... **\$994.95**

**LM30-2** analog version of above #WOLM302 ..... **\$694.95**

**LM60-2** analog 60-segment version of above #WOLM602 ..... **\$994.95**

**WOHLER TECHNOLOGIES****LM106-6**#WOLM1066  
**\$1924.95**

The LM106-6 is a professional 6-channel analog Level Metering System with an ultra-high resolution 106-segment tri-colored LED bargraph. It features sturdy mini-Phoenix connectors, dip switch level calibration, superior dynamic range, and simultaneous displaying of VU (bar) and PPM (dot) ballistics.

- Analog 6-channel in-rack level metering system
- Ideal for mobile or studio surround metering
- Ultra-high resolution 106-segment tri-colored LED bargraphs
- Adjustable front panel brightness control
- 0.5 mid-scale resolution
- Mini-phoenix connector inputs

**DORROUGH****40-A**#D040A  
**\$459.00**

The Dorrough 40-A is a professional analog loudness meter that simultaneously displays, on the same scale, the relationship between average and peak levels and their relative difference, in dB. Users can easily see the stereo mix and avoid common in-phase/out-of-phase problems, resulting in better mixes for stereo/mono broadcast and studio applications.



- Ultra-fast response time with seamless display of average/peak relationship
- 40-segment LED with 1dB resolution
- XLR inputs and 6 DIP switches for function assignments
- "A" scale metering with 14dB of headroom

**40-C** same as above with 20dB headroom scale #D040C ... **\$459.00**

**40-D** dual rack-mount for Dorrough 40A, B, C, P, N and P/S series meters #D040D ..... **\$45.00**

**SM PRO AUDIO****VU8**#SMVU8  
**\$199.00**

The VU8 is an 8-channel, 1RU stand-alone audio VU meter and

headphone monitoring unit. The unit is appropriate for broadcast, studio, and live monitoring applications, allowing for completely passive, unaltered Peak and Average metering expressed in a backlit blue background. A selectable headphone output is available for checking signal on any of the eight channels.

- Multi-channel VU and headphone monitoring unit
- Peak and Average display ballistics
- -20 to +3dB Scale and Calibration controls
- (8) XLR/TRS combo inputs and outputs
- Backlit meters with blue background
- Passive design for unaltered signal metering

**RDL****RU-SM16**#RDRUSM16  
**\$236.76**

The RU-SM16 is a 2-channel audio level meter designed to accept either balanced or unbalanced, high- or low-impedance audio lines. Rear panel jumpers select either peak or average audio level displays for each individual meter. Large tri-colored LED's are used for good visibility, with the upper three (+10, +14, +18) remaining in PEAK HOLD mode.



- 16 tri-colored LED's per channel
- Balanced or unbalanced inputs on full-sized terminal blocks
- Precise Left/Right meter tracking
- Individual channel calibration with selectable peak and average metering

**ATI****BGD200-PPMP**#ATBGD200PPMP  
**\$376.95**

The BGD200 is a 2-channel audio meter with an intense 10-segment LED, visible even in bright sunlight.



It can accept both balanced and unbalanced lines and has selectable zero reference levels at -10, +4 or +8dBu with front panel trimmers for fine adjustment. Simple, two-piece Phoenix style inputs for ease of installation.

- 2-channel, 10-segment multi-colored LED bargraph
- PPM response with Phase indicator
- Ideal for mobile audio/video production
- Balanced bridging inputs

## PHONIC PAA2

The PAA2 is a handheld audio analyzer that provides professional sound engineers with a comprehensive set of tools for determining room characteristics, levels, speaker phase, and more, with immediate feedback regarding the appropriate EQ settings for a given environment, ensuring superior mixes in both live and studio applications.

- 31-band RTA with built-in calibrated measurement mic
- Noise generator, speaker line, and phase generator
- XLR I/O, RS232 (serial) interface for computer operation
- 7-hour continuous battery life



#PHPAA2  
**\$249<sup>99</sup>**

## SAMSON D-1500

The D-1500 is a rack mount Digital Real Time Analyzer that provides

a wide variety of powerful tools for audio measurement applications. Its multi-parameter, digital RTA displays the frequency response and acoustic characteristics of any sound system accurately via its 31-band, 13-segment LED's, ideal for easily creating a flat system response with greater detail and clarity.

- 31-band RTA with adjustable meter resolution and frequency range
- Pristine 24/96kHz audio converters
- Comprehensive Signal Generator
- Capable of simultaneous display of both Peak and VU levels
- XLR I/O, phantom powered measurement mic input

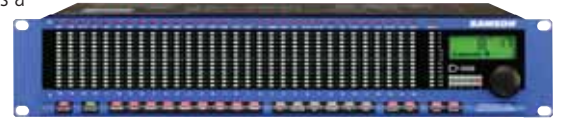

#SAD1500  
**\$249<sup>00</sup>**

## GALAXY AUDIO CM-130



The CM-130 is a compact, lightweight SPL meter featuring a built-in electret condenser microphone and large backlit display with low-, medium-, and high-level range readouts. This 9V battery-operated meter is both inexpensive and accurate, and offers selectable fast and slow response times, AC signal output, and large, easily-accessible selector buttons.

- Lightweight, miniature SPL meter with accuracy to  $\pm 2$ dB
- Built-in electret condenser mic with windscreen
- 30dB dynamic range
- 110 hours of operation using standard 9V batteries
- AC signal output

**CM-140** same as above with higher resolution, dynamic range and accuracy #GACM140 ..... **\$129.99**

#GACM130  
**\$59<sup>99</sup>**

## GALAXY AUDIO CM-150



The CM-150 is a high-quality SPL meter featuring a bright backlit display with 50-segment bar graph indicator. It provides a wide 50dB dynamic range with a resolution of 0.1dB, and can be controlled remotely via its RS-232 interface. The CM-150 can be powered using an AC adaptor or internal 9V battery.

- Accurate SPL meter with 50-segment bar graph indicator
- Low, medium, high, and Auto Ranging Levels (30-130dB)
- 1/2" electret condenser microphone
- Intuitive, easy-to-access function buttons
- Bright, backlit digital LCD screen
- RS-232 interface

#GACM150  
**\$249<sup>99</sup>**

## PHONIC PAA3

The PAA3 is a handheld audio analyzer with an array of useful features. With a 31-band real time spectrum analysis, SPL meter, noise generator, phase detector, and a reverberation time display, among other tools, it's a multifaceted device that can be operated with one hand; a crucial tool in any environment where sound needs to be measured.

- XLR input and output, USB port for PC control
- Built-in microphone
- Line signal measurement
- Large back-lit LCD screen
- Audio test signal CD & software included
- AC adaptor included / 7-hour battery operation



#PHPAA3  
**\$399<sup>99</sup>**

## RANE RA-30



The RA-30 is a professional single space Realtime Analyzer that provides 30 bands of real-time frequency/amplitude information in a 5-LED per band format. The unit serves three functions: Realtime Analyzer with Pink Noise generator, SPL meter, and Stereo VU meter with Peak Hold. It accepts balanced and unbalanced line level signals and provides a high-quality calibration mic for measurements.

- 30-band analyzer with 5 multi-colored LED's per band
- Line or mic level frequency analysis (using Class 2 filters)
- SPL meter with 1dB resolution (selectable weighting)
- 1/4" and XLR I/O

#RARA30  
**\$459<sup>00</sup>**



**BES****Contractor Tool Kit**#BECON200  
**\$429<sup>95</sup>**

The Contractor Tool Kit includes the Fiberfish II Kit, a 0.5" x 72" Auger Piran-flex bit, a 3/8" x 72" high-speed steel flex bit, a 20' fiberglass telescoping pole, an attachment kit, wisp head, flex fish, steering guide and a 1" wood auger bit, all housed in a plastic case.

**Barracuda Fish Tape**#BEBRC100  
**\$64<sup>95</sup>**

This is a heavy-duty carbon steel Fish Tape 100' in length and housed in ABS plastic, featuring an integrated secure-grip puller to prevent kinks and broken tape.

**BES****Bell-3812**#BEBELL3812  
**\$19<sup>95</sup>**

The Bell-3812 is a high-speed Bellhanger's bit for contractors measuring 3/8" x 12". It's made of M2-grade durable steel and features a cross-bore on the bit end for wire-pulling.

**Bell-1212**#BEBELL1212  
**\$19<sup>95</sup>**

The Bell-1212 is a high-speed Bellhanger's bit for contractors measuring 0.5" x 12". It's made of M2-grade durable steel and features a cross-bore on the bit end for wire-pulling.

**MONSTER CABLE****16G x 2 Direct Burial Speaker Cable**#MOCP162DB100  
**\$429<sup>95</sup>**

This color-coded 1000', 16-gauge high-performance cable is used for outdoor audio installations.

**PHILIPS****Spooled Speaker Wire**

This 18-gauge speaker wire is sold on a 100' spool for use in longer home installation runs.

#PHPH62104  
**\$17<sup>95</sup>****STANDARD WIRE****Shielded Speaker Cable**#ST162500SH  
**\$169<sup>95</sup>**

This is a 500' run of premium-grade, shielded 16-gauge/2-conductor speaker cable made for custom audio installations.

**STEREN****Economy Speaker Wire**

This is an 18-gauge, 1000' spool of standard-grade economy speaker cable for audio installations.

#STESW18  
**\$99<sup>95</sup>****BES****Magnafish**#BEMAG6589  
**\$109<sup>95</sup>**

The Magnafish is a magnetic wire-pulling kit with a 60 lb. capacity, comprised of a paddle magnet, pull-string, magnetic wire guide and a blow-molded carrying case.

**FIB-GUD**

This contractor product is a steering guide for flexible shaft bits inside of a wall cavity.

#BEFIBGUD  
**\$19<sup>95</sup>****ACOUSTIC-RESEARCH****Pro II Series 800-Watt Micro-Flat Speaker Wire****\$59<sup>95</sup>**

The Pro II Series of speaker cables is only 0.5mm in thickness, and rated to support either 800-watts or 1350-watts over 50' or 100' lengths. It comes with adhesive backing and features gold-plated terminal blocks.

**PR-391** 50' version #ACPR391 **PR-392** 100' version #ACPR392

**BES****Flexible Auger Bit**#BEAAUG3454  
**\$21<sup>95</sup>**

This is a flexible 0.75" x 54" flexible-shaft auger bit for installation applications, cross-bored at both ends for simplified wire-pulling.

**SCP****Speaker Cable**#SC1625P500  
**\$104<sup>95</sup>**

This 16-gauge/2-conductor speaker cable is color-coded, UL-listed and PVC-insulated. It is available in 500' and 1000' runs for installation applications.

**STANDARD WIRE****Custom Installation Speaker Cable**#ST162500STD  
**\$104<sup>95</sup>**

This is a 500' run of 16-gauge/2-conductor speaker cable made for custom audio installations.

**INTELIX****AVO-A2-PAC-F**#NAVOA2PACF  
**\$132<sup>95</sup>**

Stereo audio Cat5 Baluns interfaces designed to transmit analog audio signals up to 2500' through Cat5 standard structured-pair cabling. A Baluns converts a balanced signal to unbalanced and vice versa.

**AVO-A2-WP-PAC-F**

Stereo Cat5 Baluns wallplate designed to transmit analog audio signals up to 2500' through Cat5 standard structured-pair cabling. A Baluns converts a balanced signal to unbalanced and vice versa.

#INAVOA2WPPAC  
**\$74<sup>95</sup>**

## ATLAS SOUND ADZ502W

#ATADZIW  
**\$124<sup>95</sup>**

This is a 5.25" in-wall audio expansion kit for use with 8-Ohm speaker systems. The package is comprised of two 5.25" speaker systems, a 50-watt impedance-matching volume control, and 100' of 16-2 speaker wire.



## ADZ612C

#ATADZIC  
**\$124<sup>95</sup>**

This is a 6.5" in-ceiling audio expansion kit for use with 8-Ohm speaker systems. The package is comprised of two 6.5" speaker systems, a 50-watt impedance-matching volume control, and 100' of 16-2 speaker wire.



## NXG TECHNOLOGY NX-OVC

#NXNXOVCK  
**\$29<sup>99</sup>**

The NX-OVC is a weatherproof volume control housing unit designed to be mounted on an exterior wall or other flat surface. It provides protection from rain, splashing and spray for exterior volume controls near pools, saunas, or patios.



## NX-70VTR

#NXNX70VTR  
**\$13<sup>99</sup>**

The NX-70VTR is a 70V line-matching transformer for music or paging systems. It exhibits minimal insertion loss, wide frequency response, and includes multiple primary taps at 4- and 8-Ohm secondary impedances.



## NXG TECHNOLOGY NX-KP2

#NXNXKP2W  
**\$3<sup>99</sup>**

The NX-KP-2 is a white decorator-style knob replacement kit for NXG's rotary volume control units.



## NXG TECHNOLOGY NX-VCH-8

#NXNXVCHB  
**\$43<sup>99</sup>**

The NX-VCH-8 is a 2-channel, 1-in/8-out volume control distribution hub for large speaker installations. It allows connection of up to 8 volume controls and speaker pairs to a single amplifier.



## STEREN

### Fish Tape with Dispenser

This 100' steel Fish Tape includes a dispenser and is used in construction and installation work to pull wires and cables through walls, ceilings, floors and conduits.

#STFT  
**\$34<sup>95</sup>**



## IDEAL T-Stripper

The T-Stripper is a professional wire stripper featuring all-metal construction, a durable spring mechanism and precision-cut teeth.

#IDTSW  
**\$16<sup>95</sup>**



## ATLAS SOUND DAT8ST

#ATDAT8STW  
**\$28<sup>95</sup>**

The DAT8ST is a 50-watt stereo wall attenuator for 8-Ohm residential speaker systems. It features positive-off and full-power pass-through, and mounts in a one-gang electrical box.



## DAT35ST70W

#ATDAT35ST70W  
**\$36<sup>95</sup>**

The DAT35ST70W is a 25/70.7V stereo wall attenuator for constant-voltage speaker systems. It offers positive-off and full-power pass-through, mounts in a one-gang electrical box and is UL-listed.



## NXG TECHNOLOGY NX-VMS100

#NXNXVMS100W  
**\$35<sup>99</sup>**

The NX-VMS100 is a white 100-watt dimmer-style impedance-matching volume control. The 12-step slider supports from 2 to 16 speaker pairs, and the removable terminal blocks accept up to 14-gauge speaker wire.



## NX-VMS80

#NXNXVM80I  
**\$32<sup>99</sup>**

The NX-VMS80 is a white 80-watt rotary impedance-matching volume control. The 12-step knob rotation supports from 2 to 16 speaker pairs, and the removable terminal blocks accept up to 14-gauge speaker wire.



## HIFI WORKS HFW-WP1

#HIHFWWP1  
**\$12<sup>99</sup>**

The HFW-WP1 is a speaker connection wallplate with 2 sockets, 2 banana-plug receptacles, and a faceplate designed for home audio installations.



## NXG TECHNOLOGY NX-AB2

#NXNXAB2  
**\$29<sup>99</sup>**

The NX-AB2 is a 2-channel, dual-source wall-mount speaker selector switch for multi-speaker home audio applications. It allows a single pair of speakers to be switched between two amplifiers, or vice versa.



## STEREN

### Cable Caddy

This product is designed to support up to 1000' cable reels during cable installations and folds easily for storage and transportation.

#STCC  
**\$49<sup>95</sup>**



## BES LC-1025

#BELC1025  
**\$149<sup>95</sup>**

The LC-1025 is a variable size hole-cutter designed to cut through materials ranging from sheetrock and plaster to brass and aluminum. The unit cuts round holes up to 10 5/8" in diameter and includes 2 adjustable steel and tungsten steel blades.



**OKLAHOMA SOUND**

**Orator,  
Height-Adjusting  
#800**

**\$799<sup>95</sup>**

The Sound Orator #800 is a versatile lectern designed to adjust in height from 42–52". It provides a spacious reading surface, convenient digital timepiece, and a brass reading lamp for even illumination. Ideal for audiences of up to 2000, the Sound Orator #800 features a built-in 40-watt amplifier and four 6" full-range speakers.



- For mid-sized to large audiences, up to 2000
- 40-watt solid state multimedia amplifier
- Adjusts in height from 42–52"
- Wireless-ready (optional transmitter required)
- Includes (1) handheld and (1) lavalier condenser microphone
- 117 Volt AC, 12 V DC w/ optional battery
- Dimensions: 42" (lowered) H x 22" W x 17" D

Available in 4 different laminates:

**Walnut** #OK101PLSW, **Medium Oak** #OK101PLSMO, **Light Oak** #OK101PLSLO, **Mahogany** #OK101PLSM

**OKLAHOMA SOUND**

**Power Plus Lectern #101PLS**

**\$329<sup>95</sup>**

The Power Plus #101 is a contemporary-styled tabletop lectern system designed for mid-sized audiences of up to 900. It is equipped with a 30-watt multimedia amplifier that provides two microphone inputs, one line and aux input, and two line outputs.



- For mid-sized audiences up to 900
- Semi-portable tabletop design
- 30-watt solid state multimedia amplifier
- (1) 8" high-efficiency speaker
- Wireless-ready (optional transmitter required)
- Includes (1) handheld and (1) lavalier condenser microphone
- 117 Volt AC, 12 V DC w/ optional battery
- Dimensions: 14" H x 22" W x 17" D

Available in 4 different laminates:

**Walnut** #OK101PLSW, **Medium Oak** #OK101PLSMO, **Light Oak** #OK101PLSLO, **Mahogany** #OK101PLSM

**OKLAHOMA SOUND**

**#321**

**\$642<sup>95</sup>**

The #321 Folding Lectern is a two-in-one lectern system designed for easy transportation and storage. It consists of the #123 Table Lectern and a folding floor stand that converts the Table Lectern to a full-size floor podium. This versatile solution is equipped with a full-featured 25-watt multimedia amplifier and four 8" speakers.

- For small to medium audiences up to 500
- 25-watt solid state multimedia amplifier
- (4) 8" full-range speakers
- Includes (1) handheld and (1) lavalier condenser microphone
- 117 Volt AC, 12 V DC w/ optional battery
- Dimensions: 44"H x 22"W x 14"D

Available in 2 different laminates:

**Walnut** #OK321W, **Medium Oak** #OK321MO

**#123 folding table lectern only (14"H x 22"W x 14"D)**

**Walnut** #OK123W, **Medium Oak** #OK123MO ..... **\$489.95**

**OKLAHOMA SOUND**

**Table-Top Wood  
Veneer Lectern #950**

**\$1062<sup>95</sup>**



The Wood Veneer Lectern #950 is tabletop system designed for audiences up to 7500 people. Its luxurious exterior design is complemented by a built-in 75-watt multimedia amplifier and four 4" speakers mounted directly on radius corners. An optional base is available (Lectern Base #901), allowing the tabletop system to be used as a full-sized podium.

- For audiences up to 7500
- Deluxe wood veneer finish
- 75-watt solid state multimedia amplifier
- (4) 4" full-range speakers
- Wireless-ready (optional transmitter required)
- Built-in reading lamp and digital timer
- 117 Volt AC, 12 V DC w/ optional battery
- Dimensions: 28"H x 24"W x 20"D

Available in 2 different veneers:

**Mahogany on Walnut** #OK950MW, **Cherry on Cherry** #OK950CC

**Lectern Base #901** Available in 2 different veneers:

**Mahogany on Walnut** #OK901MW, **Cherry on Cherry** #OK901CC ..... **\$799.95**

**AMPLIVOX SOUND SYSTEMS**

**Tabletop Lectern System**

#AMS250WT  
**\$514<sup>95</sup>**

The Table Top Lectern System is a compact amplified lectern solution for boardroom, lecture hall and classroom presentations. The sturdy walnut-finished wooden unit features 50-watts of amplification and a 6"x 8" Jensen speaker, with a crown reach of 1500 p ersons. It is equipped with a handheld dynamic microphone and an adjustable gooseneck stand.



- XLR mic and RCA line inputs, RCA line outputs
- (10) D-cell battery, rechargeable battery or AC operation
- Dynamic mic included
- 6"x 8" Jensen speaker, 50-watt internal amplifier
- Dimensions: 14" H x 24" W x 20" D

**S2500K** Light Oak version #AMS2500K ..... **\$514.95**

**S350WT** Wireless Walnut version with column, casters #AMS350WT ..... **\$824.95**

**S3500K** Wireless Lt.Oak version with column, casters #AMS3500K ..... **\$824.95**

**S350MO** Wireless Med.Oak version with column, casters #AMS350MO ..... **\$824.95**

**S350MH** Wireless Mahogany version with column, casters #AMS350MH ..... **\$824.95**

**S450MH** Mahogany podium version with 2 speakers, casters #AMS450MH ..... **\$824.95**



**OKLAHOMA SOUND****Power Plus Lectern****\$434<sup>95</sup>**

The Power Plus #111 is a mid-sized, contemporary-styled lectern system designed for mid-sized audiences of up to 900. It is equipped with a 30-watt multimedia amplifier that provides two microphone inputs, one line & aux input, and two line outputs. A 14" table-top version (#101PLS) is also available.

- For mid-sized audiences up to 900
- 30-watt solid state multimedia amplifier
- (4) 8" high-efficiency speakers
- Wireless ready (optional transmitter required)
- Includes (1) handheld and (1) lavalier condenser microphone
- 117 Volt AC, 12 V DC w/ optional battery
- Dimensions: 45" H x 22" W x 17" D



Available in 4 different laminates: **Walnut** #OK111PLSW, **Medium Oak** #OK111PLSMO, **Light Oak** #OK111PLSLO, **Mahogany** #OK110PLSM

**OKLAHOMA SOUND****Prestige Lectern #711****\$894<sup>95</sup>**

The Prestige model #711 is a hand-crafted podium with a wide reading surface, a recessed fluorescent lamp and a surface-mounted digital timepiece. Its self-contained solid state multimedia amplifier is equipped with two microphone inputs, one line input for CD & tape playback, and two line output jacks.

- For large audiences up to 3000
- 50-watt solid state multimedia amplifier
- (4) 8" high-efficiency speakers
- Wireless-ready (optional transmitter required)
- Includes (1) handheld and (1) lavalier condenser microphone
- Power Supply: 117 Volt AC; 12 V DC w/ optional battery
- Dimensions: 47" H x 22" W x 18" D
- Unit moves easily on four concealed easy-roll castors

Available in 4 different laminates: **Walnut** #OK711W, **Medium Oak** #OK711MO, **Light Oak** #OK711LO, **Mahogany** #OK711M

**OKLAHOMA SOUND****Floor Sound Lectern #6010****\$593<sup>95</sup>**

The Floor Sound #6010 is designed for audiences up to 2500; ideal for both small and large venues. This executive-style podium is equipped with a 50-watt multimedia amplifier and two 8" high-efficiency speakers. The built-in amplifier is equipped with two microphone inputs, one line input, and two line output jacks.

- For audiences up to 2500
- 50-watt solid state multimedia amplifier
- (2) 8" high-efficiency speakers
- Wireless ready (optional transmitter required)
- Includes (1) handheld and (1) lavalier condenser microphone
- 117 Volt AC, 12 V DC w/ optional battery
- Dimensions: 46" H x 25" W x 20" D



Available in 4 different laminates:

**Walnut** #OK6010W, **Medium Oak** #OK6010MO, **Light Oak** #OK6010LO, **Mahogany** #OK6010M

**ANCHOR AUDIO****Admiral Lectern****System FL-6000**#ANFL6000  
**\$1134<sup>95</sup>**

The Admiral Lectern System serves as an ideal housing for Xtreme, Liberty, or Explorer Pro sound systems. The rich oak cabinet is equipped with a gooseneck electret microphone, a shock mounted mic input and tilt-n-roll casters. It is easily assembled with a Phillips head screwdriver and ships flat in a single box.



- Ideal for conference rooms
- Solid oak console
- Built-in gooseneck electret microphone
- Xtreme, Liberty, or Explorer Pro systems fit into console cabinet
- Dimensions: 45" H x 24" W x 21" D

**LK-LIB** all the features of the FL-6000, plus a built-in Liberty Sound System #ANLKLIB..... **\$2305.00**

**LK-XTR** all the features of the FL-6000, plus a built-in Xtreme Sound System #ANLXTR..... **\$2209.00**

**AMPLIVOX SOUND SYSTEMS****Presidential Plus Lectern System**#AMS450MO  
**\$824<sup>95</sup>**

The Presidential Plus Lectern is a great looking lectern with a built-in sound system and rugged design. It features a powerful 50 watt amplifier that drives two built-in Jensen speakers for a rich sound that projects to audiences of up to 1,500 people. The Presidential Plus Lectern includes additional inputs and outputs, four casters, and is a welcome addition to any lecture hall, auditorium, or conference hall.

- Built-in 50-watt amplifier
- (3) XLR & stereo RCA inputs
- Stereo RCA outputs
- Includes dynamic microphone with 15-foot cable & gooseneck mount
- Powers via AC or optional batteries
- 4 Casters, 2 Locking
- Dimensions: 46.5" x 25.5" x 20.5"

## MONSTER-POWER Pro AVS 2000

#MOPAVS2000  
**\$1699<sup>95</sup>**



The Pro AVS 2000 is a six-outlet rack mount Automatic Voltage Stabilizer designed to maintain constant voltage to audio gear and prevent power-line fluctuations in professional and commercial studios or high-end home theater installs. The unit provides auto-correction for voltage spikes and dips, supporting a wide 80V to 140V range, and, at close to 70 lbs, is built like a tank.

- (4) switched, (2) unswitched power outlets
- Sequential powering with programmable delay prevents on/off pops
- Safety Overload Sensor for extreme overload gear disconnect
- (3) separate meters monitor incoming voltage, amperage draw, voltage correction
- Heavy-duty 12-ft., 12-gauge AC power cord

## MONSTER-POWER Pro 1000

#MOP1000FSPC  
**\$149<sup>95</sup>**



More than a simple power strip, the Pro 1000 is a complete floor-standing power center that uses the same noise suppression and surge protection technology that Monster has made available in their rack-mountable units. This piece is the perfect addition to any performing musician's live rig and can be used to protect sensitive studio gear and mobile systems as well.

- (8) color-coded switched AC outlets
- Current and voltage availability LED bar graph meters
- Ground, wiring fault, and surge protection indicators with alarm
- Aluminum exterior with rubberized end caps
- Heavy-duty, 10-ft. shielded power cord
- Stage 2 isolation filtering with 2775 joule rating

## MONSTER-POWER Pro 7000

#MOP7000RPC  
**\$1499<sup>95</sup>**

The Pro 7000 is a top-of-the-line rack-mountable power management system that delivers clean, balanced AC to your studio environment. Twelve specially-tailored outlets provide isolated surge protection and filtering for analog, digital, high power, and computer-based equipment, giving you maximum rejection of unwanted noise-producing interference.



- (6) switched or unswitched outlet pairs
- Defeatable voltage alarm for over- or under-voltages
- Programmable power-on sequencing
- Ground, Surge, AC Filtering, and Abnormal Voltage LED's
- Extra long 8-ft. PowerLine 300 ultra-high current power cord
- Rear connections for optional Monster FlexLamp
- Stage 5 isolation filtering with a 3145 joule rating

**Monster FlexLamp** gooseneck workspace illumination #MOMPLMPXLR5.. **\$39.95**

## MONSTER-POWER Pro 3500

#MOP3500RPC  
**\$299<sup>95</sup>**



The Pro 3500 is a low-noise, 12-outlet power distribution system in a package perfectly suited to studios, performing musicians, techs, and almost any live or installed

application. Isolation between the digital and analog filtered output sections prevents audible interference from reaching adjacent outlets easily, keeping your system noise down and allowing your gear to sound its best.

- (12) switched rear and (2) unswitched front panel outlets
- Three-stage sequenced AC power turn-on and turn-off
- Digital meter for available voltage and current demand
- Separate digital, analog and high power output sections
- Front and rear connections for optional Monster FlexLamp
- Stage 3 isolation filtering with 2775 joule rating

**Monster FlexLamp** gooseneck workspace illumination #MOMPLMPXLR5..... **\$39.95**

## MONSTER-POWER Pro 2500

#MOP2500RPC  
**\$199<sup>95</sup>**



The Pro 2500 is a single rack space surge protector and AC filtering system that brings Monster quality within reach of anyone in search of clean, noise-free power. The 8 switched rear outlets are color-coded while the front panel offers 2 easily accessible unswitched outlets to make setups quick and painless.

- (8) switched rear and (2) unswitched front panel outlets
- Two-stage sequenced power turn-on and turn-off
- Three-character LED for AC voltage monitoring
- Heavy-duty, 8-ft. PowerLine 200 power cord
- Front connections for optional Monster FlexLamp
- Stage 2 isolation filtering with 2775 joule rating

**Monster FlexLamp** gooseneck workspace illumination #MOMPLMPXLR5..... **\$39.95**

## FURMAN AR-1215

#FUAR1215  
**\$549<sup>95</sup>**



The AR-15 is a professional rack-mounted AC line voltage regulator designed to protect equipment from voltage irregularities such as brownouts or over-voltages, and provide a steady, stable 120 VAC output. The "Extreme Voltage Shutdown" feature senses dangerously high or low voltages and shuts down the output before malfunctions or permanent damage sensitive digital equipment.

- (8) rear panel outlets and one front panel outlet
- Delivers a stable 120  $\pm$ 5VAC whenever the input line voltage is between 97V and 141V • Output capacity: 15 amps
- 10-LED bar graph input voltage meter
- Extreme voltage shutdown indicator LED • Circuit breaker on/off switch

## FURMAN IT-20II

#FUIT202  
**\$1699<sup>95</sup>**



The IT-20II powering system feeds balanced and noise-free AC to your recording studio, broadcast station, or video production facility with failsafe construction and maintenance-free operation.

Balanced power all but eliminates inducted hum between connected devices, while multi-stage voltage suppression and extreme voltage shutdown circuitry protect your investments.

- 20 amp capacity with constant 120V output within capture range • (12) rear isolated ultra-low resistance Hubbell outlets • (2) front GFCI protected 20 amp outlets
- Ground lift switch to eliminate AC hum and ground noise • Provides over 80dB of common mode noise rejection • Protection and voltage overload indicators with voltmeter

**Furman RRM-2** rear rack-mount ears for AR-1230 #FURRM2AR1220.....**\$69.00**

**Furman ADP1520** 20 to 15 amp plug adaptor #FUADP1520.....**\$18.00**

## FURMAN AR-20 II

#FUAR20II  
**\$1399<sup>00</sup>**

The AR-20 II is a professional 20-amp voltage regulator that transforms the irregular fluctuations from your incoming AC into a constant



120V stream, keeping sensitive electronic gear running smoothly. Housed in a sleek and sturdy 2 rack space chassis, it is designed to be a simple and maintenance-free surge suppression system, AC filter, and stable power source.

- 20-amp capacity with optional 15-amp adaptor plug
- (12) rear and (2) front panel regulated outlets
- Three character-selectable voltage/current meter
- Regulation, protection, and extreme voltage indicators
- The only 20-amp regulator with noise filtering

**Furman ADP1520** 20 to 15 amp plug adaptor #FUADP1520.....**\$18.00**

## FURMAN PlugLock

#FUPLUGLOCK  
**\$39<sup>95</sup>**



The PlugLock is an inexpensive outlet strip with outlets spaced widely enough apart for bulky "wall wart" transformers. Easily secure cumbersome power supplies with the locking adjustable clamps.

- Mounts safely out of sight, in the back of your rack
- Can lock regular plugs as well as wall warts
- Heavy-duty, 5-ft. 14 AWG 3-conductor power cord
- Rated for 15 amps with circuit-breaker protection
- Clamps adjust from 0.4"– 2.1" above outlet
- All-steel construction

## FURMAN Power Factor Pro

#FUPFPRO  
**\$379<sup>95</sup>**



Furman's Power Factor Pro Conditioners are specifically designed to provide clean power for guitarist, bassist, and keyboard players. Clubs, bars, and rehearsal rooms are notorious for having less than reliable AC power, and the Power Factor Pro use specialized technologies to optimize it for musician's specific needs. The Power Factor Pro features: Clear Tone Technology, SMP+ (Series Multi-Stage Protection Plus), LiFT (Linear Filtering Technology), and E.V.S. (Extreme Voltage Shutdown) over voltage circuitry.

- 4 Rear outlets • Line Voltage Meter
- Master switch controls all outlets
- Series Multi-Stage Protection (SMP)
- Automatic Extreme Voltage Shutdown (EVS)
- Zero ground contamination circuitry



## RAXXESS PD-800VM



#RAPD800VM  
**\$104.95**

The PD-800VM is a high-quality, economical rack-mounted power conditioner with eight rear-panel outlets, surge/spike protection, and front-panel voltage metering. Featuring two front panel pull-out lights with an on/off switch, the PD-800VM provides a convenient light source for both stage and studio racks.

- (8) evenly-spaced outlets (accepts wall warts)
- 15-amps rating
- Front-mounted circuit breaker
- RFI and EMI surge protection
- 12-ft., 14-gauge power cord

**PD-800L** same as PD-800VM, but without front voltage metering #RAPD800L.....**\$87.50**

**PD-800** same as PD-800L, but without front panel lights #RAPD800.....**\$64.95**

## ALESIS PowerTrip8



#ALPOWERTRIP8  
**\$99.00**

The PowerTrip8 is an 8-outlet single rack space power module that is an ideal control unit for any rackmount system. The fast-acting surge suppression responds in less than a nanosecond and the interference filtering works to prevent radio or electromagnetic waves from entering your system, which would normally cause audible noise.

- (8) outlets with high-voltage surge and transient suppressor
- Front-panel LED voltage meter with bright, clear display
- Two pull-out light bars (with dimmer) illuminate entire rack
- RFI and EMI filtering keep unwanted noise out of your system
- Single rack space makes it an easy addition to your system

## FURMAN PS-Pro II



#FUPSPROII  
**\$319.00**

The PS-Pro II is a rack-mounted power conditioner/sequencer capable of powering up a rack full of equipment in a three-step delayed sequence (the sequence is reversed for power-down). It features comprehensive surge suppression and line noise conditioning, nine outlets, and a BNC jack for attachment of a gooseneck lamp.

- (6) switched outlets (on rear panel), and (3) unswitched outlets (one front, two rear)
- SMP+ (Series Mode Protection Plus) non-sacrificial surge suppression
- LiFT (Linear Filtering Technology) with zero ground contamination
- Extreme voltage shutdown • Capable of remote remote operation
- 10-ft., 12-gauge, heavy-duty power cord

## FURMAN PL-PRO II, PL-PRO D II, PM-PRO II



#FUPLPROII  
**\$319.95**

#FUPLPRODII  
**\$324.95**

#FUPMPROII  
**\$374.95**

The 20-amps PRO II series rack-mounted power conditioners offer Furman's most comprehensive protection from power line-related transient voltages, noise, and wiring faults. These top-of-the-line conditioners all provide eight switched rear-panel outlets and one unswitched front-panel outlet.

**PL-PRO II:** features a 20-segment incoming AC line voltage meter  
**PL-PRO D II:** features an ultra-accurate, front-panel digital AC meter  
**PM-PRO II:** features ultra-accurate, front-panel digital AC and current meters

- PL-PRO II and PL-PRO D II have (2) front-panel retractable lights w/dimmers
- 20-amps rating • SMP+ with Extreme Voltage Shutdown guards against destructive wiring faults • LiFT (Linear Filtering Technology) with zero ground contamination
- Heavy-duty 10-ft., 12-gauge power cord

## FURMAN Merit Series

#FUM10  
**\$39.95**

#FUM8  
**\$54.95**

#FUM8L  
**\$84.95**

#FUM8D  
**\$119.95**



The affordable Merit Series rack-mounted power conditioners/light modules are available in four models, each with eight switched outlets on the rear panel, and an additional one on the front (the M-10, which has ten rear panel outlets only). The M-8L and M-8D feature two slide-out swiveling light fixtures, and the M-8D adds a bright red, three digit LED meter that displays incoming AC line voltage. The M-8 is designed for applications where lights are not required.

- Fast-acting transient voltage suppression and RFI/EMI interference filter
- AC Voltmeter (if present): Range 60 to 150VAC; accuracy  $\pm 2\text{VAC}$
- Separate "Rack Lights" switch and dimmer control knob for lamps (if present)
- Circuit breaker provided with push-button reset
- Maximum output current: 15 amps • Heavy-duty, 6-ft., 14 AWG 3-conductor power cord

**MONSTER-POWER**

**Pro 800**

The Pro 800 is a well thought-out surge protector that fits easily into any gig bag, giving you the assurance of protected AC wherever you may need it. Well-labeled outlets, room for bulky power supplies, and gold-plated contacts for maximum power transfer help put it in a class above the everyday power strip.

#MOP800HPPC  
**\$79<sup>95</sup>**

- (8) color-coded outlets for easy gear identification
- Audible and visible indicators for ground and surge protection
- Flat plug exhibits lower profile
- Heavy-duty, 10-ft. shielded power cord
- Stage 1 isolation filtering with 1850 joule rating



**FURMAN**

**PST-8**



#FUPST8  
**\$135<sup>00</sup>**

The Furman PST-8 is a portable surge protector and AC filtering system that goes well beyond what is

found in traditional power strips. Unlike Furman's latest advances in AC conditioning, ordinary units make use of older technologies that may not only leak voltage to circuit ground, but provide uneven noise filtering. With the PST-8, it is possible to have clean and quiet AC power anywhere.

- (8) linearly filtered outlets, two of which accept wall-wart power supplies
- Highly visible protection-ok and extreme voltage indicators
- Transient voltage surge suppression for telephone, cable, and satellite lines
- Zero ground contamination assures clean power to critical audio/video gear
- Extreme-voltage shut-down circuit prevents AC overload damage

**Furman PST-6** (6) filtered outlet version #FUPST6 ..... **\$85.00**

**HOSA**

**PWA-421**

**IEC Female to 3-Prong male adapter**

The PWA-421 is an adapter that allows any standard 3-Prong extension cord to be turned into an IEC cable for amps, powered monitors, mixers, keyboards, etc.

#HOPWA421  
**\$3<sup>49</sup>**



**HOSA**

**PWD-401**

**Multi-Head Power Cord**

The PWD-401 is a unique power cord that provides an additional 3-Prong outlet from equipment powered by IEC cables, and can be used to clean up racks by daisy-chaining multiple PWD's together.

#HOPWD401  
**\$6<sup>95</sup>**



- 1-ft., 14-gauge cord • 15-amps rating, Voltage rating 125V
- Also available in 2-ft. length (PWD-402)

**MONSTER-POWER**

**Outlets To Go**

**4 Outlets**

#MOMPOTG400WH  
**\$19<sup>95</sup>**



If you are a traveling musician you already know that hotel rooms and makeshift laptop recording locations never seem to offer enough AC outlets to connect all your gear. The Outlets To Go series from Monster allows you to pack more AC connectivity conveniently into an ultra-thin design that you can tote easily in your gear bag. It also includes a FlatProfile Plug and FlatWrap Cord for even more space savings.

- (4) outlet ultra-compact design
- Resettable circuit breaker protection
- Blue illuminated plug indicates On status
- Cord management eliminates dangling cables

**Monster Outlets To Go 6 Outlets** (6) outlet version of above #MOMPOTG600WH ..... **\$29.95**

**MONSTER POWERLINE**

**200 IEC**

**power cord**

#MOPL200PRO8  
**\$49<sup>95</sup>**



- High-performance power connection for A/V components
- 24k gold-plated contacts for maximum conductivity
- 100% mylar foil shield for superior rejection of EMI and RFI
- 8-ft. length

**MONSTER POWERLINE**

**100 IEC**

**power cord**

#MOPL100PRO8  
**\$29<sup>95</sup>**



- Improved power connection for A/V components
- 24k gold-plated contacts for maximum conductivity
- Heavy-duty Duraflex jacket for protection from snags, kinks, and tears
- 8-ft. length

**RADIAL ENGINEERING****J48**

Active direct box ideally suited for studio, broadcast, and stage use.

- Active 48V phantom-powered direct box
- Minimal power draw with high-rail voltage
- Will not choke when driven hard
- Low inter-modulation distortion



#RAJ48  
**\$199<sup>99</sup>**

**RADIAL ENGINEERING****JDI**

High-quality passive direct box for critical recording or live performance applications.

- Jensen Transformer equipped passive DI
- 100% isolation eliminates ground loops
- Virtually zero phase & harmonic distortion
- Exceptional signal handling
- High common mode noise rejection

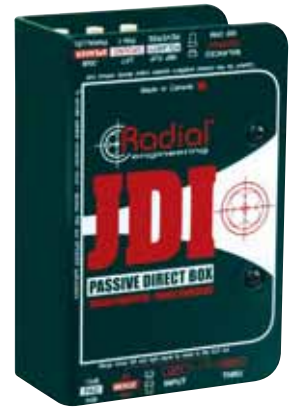

#RAJDI  
**\$199<sup>99</sup>**

**RADIAL ENGINEERING****JPC****Stereo PC-A/V Direct Box**

Stereo direct box specifically designed for use with computer sound cards and consumer electronic products

- Stereo DI for computer sound cards & A/V
- Transformer isolation eliminates ground loops
- Converts -10dB to balanced XLR mic level
- Active drive circuit for long cable runs
- 48V phantom power eliminates batteries

#RAJPC  
**\$199<sup>99</sup>**

**PRO-CO****DB-1**

Passive direct box with speaker/line-level attenuator, high-cut filter, and ground lift switches

- Floating transformer-balanced XLR output for maximum isolation
- SPKR (speaker) mode handles amplifiers up to 600 watts
- High-cut filter reduces distortion
- Ground lift switch eliminates hum and buzz
- Passive design requires no batteries or phantom power

#PRDB1  
**\$99<sup>95</sup>**

**BBE****DI 1000**

A high-quality active/passive DI with built-in Sonic Maximizer, and Jensen output transformer

- Jensen JT-DB-EPC Transformer for warmth and presence
- Purely passive or completely active operation
- Switchable 0/15dB/30dB pad switch
- Ground lift switch
- Balanced XLR Output



#BBD1000  
**\$249<sup>99</sup>**

**PRO-CO****CB-1**

Passive direct box with ground lift switch and high-cut filter

- Single-channel passive direct box
- Floating transformer-balanced XLR output for maximum isolation
- High-cut filter reduces distortion
- Ground lift switch eliminates hum and buzz
- Passive design requires no batteries or phantom power



#PRCB1  
**\$59<sup>50</sup>**

**BBE****DI100X**

Professional-grade active DI box with a built-in Sonic Maximizer processor

- Built-in, full-function BBE Sonic Maximizer
- 15dB pad switch
- Ground lift switch
- Electronically-balanced XLR output
- Recessed switches to reduce the opportunities for damage

#BBD100X  
**\$149<sup>99</sup>**

**BEHRINGER****ULTRA-DI DI100**

Economical, rugged DI Box for stage and studio applications

- Internal battery automatically shuts off when phantom power is connected
- Direct connection of amplifier outputs with ratings of up to 3,000 watts
- Switchable input attenuation
- Ground lift switch

#BED100  
**\$39<sup>99</sup>**



**WHIRLWIND****Direct 2**#WHD2  
**\$132<sup>95</sup>**

Two-channel direct box for converting unbalanced stereo signals from keyboards, CD and tape players, and computer sound cards

- 1/4" parallel wired in/out jacks
- Ground lift switch to help eliminate hum and buzz
- 20dB pad switch for connection to "hot" input signals

**WHIRLWIND****HOTBOX**#WHHB  
**\$126<sup>95</sup>**

High-quality active direct box that operates with batteries or phantom power

- Super-clean front-end circuitry
- 1/4" parallel wired in/out jacks
- Ground lift switch to help eliminate hum and buzz
- Input switch selects between instrument/line or speaker level input signals
- LED indicates "ON" status

**WHIRLWIND****DIRECTOR**#WHD  
**\$82<sup>95</sup>**

Direct Box with 30dB pad and high-cut filter switches for studio or PA applications

- 1/4" parallel-wired in/out jacks
- Ground lift switch helps eliminate hum and buzz
- 30dB pad switch for selecting between line/instrument or speaker level input signals
- Switchable high-cut filter

**COUNTRYMAN****Type 85**#CODB  
**\$159<sup>95</sup>**

High-quality direct box with top-quality components and Class-A circuitry

- Single-ended Class-A circuit
- Internal electronics are molded into a solid epoxy block
- Ground lift switch eliminates noise and buzz
- Pickup mode and Speaker mode switch allows -10dB and -46dB operation
- Powered via phantom or internal 9V battery

**WHIRLWIND****IMP 2**#WHIMP2  
**\$41<sup>95</sup>**

Built ruggedly on the inside and outside, the world-famous IMP 2 DI is found in pro systems everywhere.

- 1/4" parallel wired in/out jacks with XLR output
- Transformer is riveted, not glued, to the chassis
- Professional quality and durability

**BSS AUDIO****AR-133**#BSAR133  
**\$169<sup>95</sup>**

The AR-133 is an active audio direct box and line balancer. The unit is powered by either a 9-volt battery or phantom power.

- Rugged aluminum chassis
- Ground-lift switch
- Input pad switch with switchable 0, -20, or -40dB attenuation
- God for keyboards, amplifiers, or electric guitars and basses

**WHIRLWIND****PCDI**#WHPCDI  
**\$139<sup>95</sup>**

Direct box with RCA connectors designed to interface unbalanced stereo line sources with professional, balanced, low-impedance equipment

- Color-coded RCA phono in/thru jacks
- Color-coded XLR output jacks
- Ground lift switch to help eliminate hum and buzz
- 20dB pad switch for connection to "hot" input signals

**ART****X-DIRECT**#ARXD  
**\$40<sup>00</sup>**

Single-channel phantom or battery-operated active Direct Box

- 1/4" TRS and XLR inputs/ XLR output
- Powered via internal 9V battery or phantom power
- The Input Attenuator switches allow for a wide range of signal levels
- Switchable low-pass filter
- Phase invert switch
- Compact, black, anodized all-aluminum case

## ROLLS SE162

The SE162 Red Square is an instrument direct box/impedance-matching device with a sonic exciter built in.

- (1) 1/4" input and (1) XLR and (1) 1/4" output
- Bypassable sonic exciter with Bottom control
- Definition control adjusts presence



#ROSE162  
**\$82<sup>50</sup>**

## TAPCO DB-1A

The DB-1A is an Active direct box that can be powered either internally by two 9-volt batteries or externally by phantom power from a mixer.

- 1/4" input and (1) XLR output
- Convenient stackable design
- Ground lift helps eliminate buzz and hum



#TADB1A  
**\$49<sup>99</sup>**

## WHIRLWIND EDB1



The EDB1 is an economical direct box offering rugged construction while maintaining exceptional sound quality.

- Pad switch for connection to "hot" signal sources
- Metal construction and quality transformer
- Ground Lift switch to help isolate hum and buzz

#WHEDB1  
**\$28<sup>50</sup>**

## HOSA DIB-307A



The DIB-307A boosts guitar and bass signals up to line level for direct-to-mixer connections via either Low-Z or Hi-Z inputs.

- Amplifier speaker output may be routed to console
- Ground Lift Switch reduces 60-cycle hum.
- Rugged die cast aluminum chassis for durability

#HODIB307A  
**\$79<sup>95</sup>**

## BEHRINGER ULTRA-DI DI20

The ULTRA-DI DI20 is an active 2-channel direct DI-box and splitter that may be powered by 9V battery or phantom power.

- Up to 40dB of input attenuation
- Split mode allows 3-way output
- Ground lift eliminates ground loop problems



#BEDI20  
**\$29<sup>99</sup>**

## RADIAL ENGINEERING Pro48

The Radial Pro48 is a high-performance 48V phantom-powered active direct box designed specifically for higher-output instruments. This box is perfect for battery-powered active basses and acoustic guitars that tend to overload other direct boxes.

- Compact, rugged book-end design
- Increased dynamic range and headroom
- 48V phantom-powered with digital switching



#RAPRO48  
**\$139<sup>99</sup>**

## WHIRLWIND Direct-JT

Whirlwind's top-of-the-line passive DI features the Jensen JT-DB-EPC transformer—world renowned for wide frequency response and superior noise rejection characteristics.

- Extruded aluminum housing
- Thru output passes signal to second destination
- Selectable speaker emulation



#WHDJT  
**\$175<sup>95</sup>**

## WHIRLWIND Direct2-JT

The DIRECT2-JT is Whirlwind's premium passive Dual Direct box, built with Jensen transformers.

- Isolated grounds for each section
- Combine button creates dual inputs per channel
- -20dB pad for handling hot signals



#WHD2JT  
**\$339<sup>95</sup>**

**RADIAL ENGINEERING**

**ProDI**

#RAPRODI  
**\$99<sup>99</sup>**

The Pro DI full-range passive direct box is equipped with custom-made audio transformers for exceptional signal handling without saturation.

- Isolation transformer eliminates noise
- Compact and rugged design
- Ideal for live and studio



**RADIAL ENGINEERING**

**ProD2**

#RAPROD2  
**\$149<sup>99</sup>**

The dual-channel ProD2 delivers exceptional clarity and definition at an attractive price point.

- Very low harmonic and phase distortion
- Made of 14-gauge steel for extreme durability
- Ideally suited for acoustic guitar, bass, and keyboards



**ROLLS**

**ADi6**

#ROADI6  
**\$64<sup>95</sup>**



The ADi6 is an active direct box designed to convert a high-impedance signal and convert it to low impedance.

- Paralleled or Mix Inputs
- Variable Attenuation
- Ground Lift
- Battery or Phantom Power operation

**WHIRLWIND**

**Direct4**

#WHD4  
**\$279<sup>95</sup>**



The Direct4 is a floor-style direct box that houses four completely separate DIs in a single rugged casing.

- Extremely durable casing with solid transport handle
- Isolated grounds for each section
- Filter switch to help reduce amplifier noise and hiss

**BEHRINGER**

**ULTRA-DI DI4000**

#BEDI4000  
**\$79<sup>99</sup>**



The DI4000 is a 4 channel multi-purpose DI for stage and studio applications that features its own internal power supply.

- 8-segment LED level metering
- Switchable High Cut filter on each channel
- Illuminated switches for dark stage environments

**WHIRLWIND**

**HotBox Quad**

#WHHBQ  
**\$479<sup>95</sup>**



The HotBox Quad features 4 channels of super-clean active DI performance in a 1U rack package with built-in power supply.

- Roadworthy construction
- 1/4" parallel wired in/out jacks with XLR output
- Signal and Clip indicators on every channel

**WHIRLWIND**

**MultiDirector**

#WHMLTDIR  
**\$279<sup>95</sup>**



The MultiDirector represents 4 DIs housed in one convenient 1U rack package and is the touring sound standard for passive direct boxes.

- Passive unit requires no power
- -20dB pad available for all inputs
- (4) Color coded XLR outputs

**PRO CO**

**DB-4A**

#PRDB4A  
**\$284<sup>95</sup>**



The DB-4A provides four independent direct box channels in a convenient single rack space unit.

- (4) floating transformer-balanced XLR outputs
- Perfect for keyboards, drum machines, etc.
- Line mode handles signals up to +34dBv



**AUDIO-TECHNICA****AT8801****Single-channel 48V Phantom Power Supply**

The AT8801 provides 48V phantom power for a single microphone.

- Highly-regulated power supply provides a constant voltage source
- Rugged steel case
- Includes a plug-in power module w/6-ft. cable



#AUAT8801  
**\$62<sup>95</sup>**

**AUDIO-TECHNICA****CP8506****Four-channel 48V Phantom Power Supply**

The CP8506 provides 48V phantom power for up to four condenser microphones.

- Highly-regulated power supply provides a constant voltage source
- Rugged steel case
- Includes an attached 6-ft. ground-line cord w/ power switch



#AUCP8506  
**\$139<sup>95</sup>**

**ART****Phantom II****2-Channel Battery-Operated Phantom Power Supply**

The PHANTOM II is a 2-channel portable phantom power supply with XLR connectors that operates on two 9V batteries.

- Two-channel, 12/48V phantom power supply
- Lightweight, portable design
- Ultra-quiet operation

#ARADPP  
**\$60<sup>00</sup>**

**ROLLS****PB224**

The PB224 is a 2-channel portable 48V phantom power supply with XLR I/O connectors, powered by dual 9V batteries or an optional AC power supply.

- Portable battery-operated 2-channel 48V power supply
- Power-on LED
- Clean output, molded plastic battery compartment



#ROPB224  
**\$84<sup>95</sup>**

**ART****PHANTOM III****Single-Channel Phantom Power Supply**

The PHANTOM III is a single-channel phantom power supply with XLR connectors.

- Single-channel, 48V phantom power supply
- Lightweight, portable design
- Ultra-quiet operation



#ARPPS  
**\$50<sup>00</sup>**

**WHIRLWIND****Micpower**

The Micpower allows you to use high quality electret-condenser microphones in direct-to-recorder applications or with mixers lacking phantom power.

- Portable source of 12-18V phantom power
- Features a "Battery OK" LED
- (2) 9V batteries provide about 50 hours of continuous use



#WHMICP1  
**\$98<sup>95</sup>**

**EBTECH****Hum X**

The Hum X filters out unwanted voltage and current in the ground line that cause ground loop hum while simultaneously maintaining a solid, safe ground.

- Works with any 15amp outlet
- Removes ground hum
- Maintains safe ground

#EBHX  
**\$59<sup>95</sup>**

**RADIO DESIGN LABS****AV-HK1X**

The AV-HK1X is a mono transformer isolation module for use with a balanced, low-impedance source and either a low or high impedance load. It breaks noise-producing ground loops.

- Provides isolation in balanced lines
- Ground loop elimination
- XLR input and (1) XLR output

#RAAVHK1X  
**\$100<sup>56</sup>**

**EBTECH**

**HE-8**

8-Channel Hum Eliminator/Line Level Shifter

#EBHE8  
**\$219<sup>95</sup>**

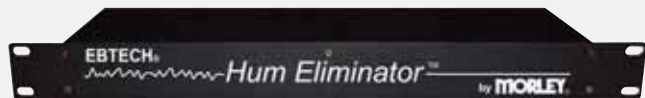

The HE-8 is a rack-mount unit that eliminates 60-cycle hum caused by ground loops, and converts unbalanced lines to true balanced lines.

- (8) 1/4" TRS inputs and outputs
- Eliminates AC hum/60Hz buzz and noise quickly and easily
- Completely passive design
- Converts back and forth between balanced and unbalanced lines

**PRO CO**

**IT-4**

#PRIT4A  
**\$299<sup>95</sup>**

The IT-4 provides 4 high-quality line level output transformers for applications that require a superior degree of electrical isolation.



- XLR and 1/4" phone connectors
- (4) channels in a single rack space
- All connectors accessible from front

**PRO CO**

**IT-1**

#PRIT1  
**\$139<sup>95</sup>**



The IT-1 isolation transformer minimizes interference from lighting dimmers, radio transmitters, and 60Hz AC power wiring.

- True floating transformer isolation
- Can be used as a line level direct box
- Ideal for portable and permanent sound systems

**RADIO DESIGN LABS**

**AV-HK1**

#RDLAVHK1  
**\$91<sup>33</sup>**



The AV-HK1 is a stereo transformer isolation module for use with unbalanced, high-impedance audio inputs. Its use eliminates noise-producing ground loops.

- Provides isolation in unbalanced lines
- Ground loop elimination
- (2) RCA inputs and (2) RCA outputs

**HOSA**

**HEM-331**

#HOHEM331  
**\$91<sup>95</sup>**

The HEM-331 Hum Eliminator is designed to get rid of ground loop problems, such as AC hum or buzz and/or pop noise in any audio system.

- Balanced to unbalanced conversion
- (2) ground lift switches
- (2) TRS phone inputs and (2) TRS phone outputs



**EBTECH**

**HE-2**

#EBHE2  
**\$59<sup>99</sup>**

2-Channel Hum Eliminator/Line Level Shifter

The HE-2 eliminates 60-cycle hum caused by ground loops, and converts unbalanced lines to true balanced lines.

- Stereo 1/4" TRS I/O (includes 4 RCA adapters)
- Eliminates AC hum/60Hz buzz and noise quickly and easily
- Completely passive design
- Converts back and forth between balanced and unbalanced lines



**WHIRLWIND**

**ISO-8**

#WHISO8  
**\$399<sup>95</sup>**



The ISO-8 provides 8 channels of XLR line isolation when a ground lift is just not enough to minimize hum and buzz in your system.

- Balancing and isolation with XLR connectors
- Flat frequency response
- Additional ground lift per channel

**WHIRLWIND**

**ISO-8Q**

#WHISO8Q  
**\$399<sup>95</sup>**



The ISO-8Q is the perfect 8 channel 1/4" phone hum fighter where different pieces of gear are connected across long lines.

- Balancing and isolation with 1/4" phone connectors
- Quality transformers for low distortion
- Single unit rack space design

## JK AUDIO Pureformer

The Pureformer provides hum and noise reduction for sound cards and audio equipment, and removes ground loops and DC paths that can cause hum and signal breakup.

- (2) RCA inputs and (2) RCA outputs
- Durable diecast aluminum construction
- High-quality, 600-ohm audio transformers



#JKPUR  
**\$58<sup>95</sup>**

## ROLLS Buzz Off

The HE18 is a two-channel audio hum and buzz remover that will convert an unbalanced signal into a balanced signal, and vice versa.

- Eliminates ground loop hum and buzz
- Leaves signal grounds connected
- Passive; the unit requires no power.



#ROHE18  
**\$64<sup>95</sup>**

## BEHRINGER MicroHD HD400



The HD400 is a two-channel unit that removes AC hum and noise by safely removing noise-producing ground loops.

- (2) 1/4" TRS phone inputs and (2) 1/4" TRS phone outputs
- Converts between balanced and unbalanced signals
- No inherent signal loss

#BEHD400  
**\$19<sup>99</sup>**

## SAMSON S-Convert



S-Convert is a problem solver for interfacing and level matching consumer and professional audio equipment.

- (2) XLR and (2) RCA inputs with (2) XLR and (2) RCA outputs
- Level control for XLR and RCA inputs
- 18V AC adapter included

#SASCONVERT  
**\$49<sup>00</sup>**

## PRO CO AV-1A

The AV-1A allows the line- or speaker-level outputs of AV equipment to be connected to the microphone inputs of house or portable P.A. systems.

- Better sound from projectors, phonographs and recorders
- Ideal for meetings, lectures, and presentations
- 16-ohm dummy load prevents amplifier damage



#PRAV1A  
**\$123<sup>50</sup>**

## RANE BB22

The BB 22 Balance Buddy converts unbalanced -10dBV consumer level RCA outputs up to balanced +4dBu professional XLR inputs.

- (2) XLR male output and (2) RCA input connectors
- Balanced output allows for longer cable runs
- Adds no additional noise



#RABB22  
**\$149<sup>00</sup>**

## ROLLS DB25

The DB25 is a transformer-balanced, passive direct box that features a Ground Lift switch for hum elimination.



- Selectable 0dB, 20dB or 40dB pad
- (2) 1/4" paralleled inputs (1) XLR output
- Recessed switches

#RODB25  
**\$26<sup>95</sup>**

## ROLLS MB15

The MB15 ProMatch converts consumer level stereo RCA signals to balanced XLR professional line level, and back.



- (2) XLR and (2) RCA inputs
- (2) XLR and (2) RCA outputs
- Each side has stereo level controls

#ROMB15  
**\$59<sup>95</sup>**



## APHEX 228

#AP228  
**\$379<sup>00</sup>**



The 228 is an 8-channel unidirectional level matching interface that connects the output of consumer equipment to the input of professional gear.

- (8) discrete -10dBV RCA inputs
- (8) discrete +4dBu XLR outputs
- Extended Range VU meter

## ART T8

#ART8  
**\$149<sup>00</sup>**



The T8 is a totally passive audio interface that uses 8 transformers to separate input and output signal grounds, thereby isolating two systems and reducing hum and ground-loop noise.

- (8) XLR, 1/4" Phone and RCA inputs and outputs
- Reversible mounting ears
- May also be used as a signal splitter

## WHIRLWIND LM2B

#WHLM2B  
**\$148<sup>50</sup>**



This handy little box can be used to match consumer-grade audio devices (-10dB) to pro equipment (+4dB).

- (2) RCA and (1) 1/8" mini input
- (2) XLR balanced outputs
- Individual left and right level controls
- Included power supply

## WHIRLWIND LM2U

#WHLM2U  
**\$122<sup>95</sup>**



This unit matches the level and provides the conversion from balanced professional-grade devices (+4) to unbalanced devices (-10).

- (2) XLR balanced inputs
- (2) RCA and (1) 1/8" mini output
- Individual left and right level controls
- Included power supply

## RADIAL X-Amp

#RAXA  
**\$199<sup>99</sup>**

The Radial X-Amp is an active re-amping device that allows a pre-recorded track from a line level device to drive two guitar amplifiers or effect pedals simultaneously.

- Allows creative manipulation of recorded guitar track
- Two amps may be driven simultaneously
- LED peak indicator and level control



## RADIAL JD7

#RAJD7I  
**\$1099<sup>99</sup>**

The Radial JD7 Injector is a guitar signal distribution amplifier that allows a guitar signal to drive as many as seven amplifiers simultaneously without loss or coloration.

- Jensen transformers eliminate 60-cycle hum
- May be used as a direct box • 1/4" inputs and outputs provided
- Balanced inputs accept prerecorded signals from mixer



## RADIO DESIGN LABS AV-DC4

#RDAVDC4  
**\$223<sup>25</sup>**

The AV-DC4 is a mono transformer-coupled audio divider/combiner module for use with balanced, low- or high-impedance audio inputs and outputs.

- (4) XLR inputs and (4) XLR outputs
- Mono input can feed up to (3) outputs
- Stereo sources can be combined to mono



## WHIRLWIND Split 6

#WHSPLIT6  
**\$76<sup>50</sup>**



The Split 6 provides a well-built solution for splitting a line level signal up to 6 times for feeding multiple destinations.

- XLR female input wired to (6) XLR male outputs
- Feed multiple powered speakers or split intercom lines
- Microphone level safely split by 2

**PRO-CO****MC-2****2-to-1 Microphone Combiner**

The MC-2 is designed for combining the signals from 2 XLR microphones to 1 XLR mixer input.

- Polarity reverse switch on second input
- Uses Pro Co MBT-2 transformer
- Rugged Uni-box construction



#PRMC2  
**\$124<sup>95</sup>**

**WHIRLWIND****IMP Combiner****2-to-1 Microphone Combiner**

The Whirlwind Microphone Combiner is a 2-input, 1-output XLR signal combiner.

- (2) XLR inputs and (1) XLR output
- Phase reverse switch flips the polarity of Input #2



#WHIMCOM  
**\$94<sup>50</sup>**

**WHIRLWIND****IMP Line Level Combiner****2-to-1 Line Level Combiner**

This unit combines two line level signals into one output, and compensates for the 6dB of gain that occurs when two in-phase signals are combined.

- (2) XLR inputs and (1) XLR output
- Ground lift switch

#WHIMCOML  
**\$107<sup>50</sup>**

**WHIRLWIND****SP1x2****1x2 Microphone splitter**

The SP1x2 provides one direct and one transformer-isolated output, from a microphone level input.

- (1) XLR inputs and (2) XLR outputs
- The transformer isolated output features a ground lift switch

#WHSP1X2  
**\$86<sup>95</sup>**

**WHIRLWIND****SP1x3****1x3 Microphone Splitter**

The SP1x3 provides one direct and two transformer-isolated outputs, from a microphone level input.

- (1) XLR inputs and (3) XLR output
- The transformer-isolated outputs feature a ground lift switch.



#WHSP1X3  
**\$99<sup>95</sup>**

**WHIRLWIND****MLTSP1x2****Multisplitter**

The MLTSP1x2 provides four channels of passive and isolated microphone splitting in a single space rack panel.

- (4) XLR inputs and (8) XLR outputs
- One direct and one transformer-isolated output per channel
- Each isolated output has a front panel ground lift switch.

#WHMLTSP1X2  
**\$317<sup>95</sup>**

**PRO-CO****MS-2****1-to-2 Microphone Splitter**

The MS-2 is designed for splitting the signal from a Low-Z balanced microphone between two mixers.

- (1) XLR input and (2) XLR outputs (Direct and Isolated)
- Isolated output has ground lift switch
- Uses Pro Co MBT-1 transformer

#PRMS2  
**\$99<sup>95</sup>**

**PRO-CO****MS-3****1-to-3 Microphone Splitter**

The MS-3 is designed for splitting the signal from a Low-Z balanced microphone between 3 mixers.

- (1) XLR input and (3) XLR outputs (1 Direct and 2 Isolated)
- Isolated outputs have ground lift switches
- Uses Pro Co MBT-1 transformer

#PRMS3  
**\$122<sup>95</sup>**

**ROLLS****Cable Detective CT 1**

Any musician or sound person knows how difficult it is to maintain cables. The CT 1 provides an efficient way to detect shorted or open cables. The unit tests 1/4" TS, 1/4" TRS, RCA, XLR, and MIDI cables plus cross combinations, preparing you for just about any audio situation. Three front-panel LED's make verification a breeze even in dark stage settings.

#ROCT1  
**\$53<sup>95</sup>****WHIRLWIND****Tester**

This versatile cable tester checks many varieties of audio cable. It tests most cable combinations of XLR, 1/4", or RCA Phono plugs for shorts, opens, and polarity reverse. The hands-free design allows manipulation of the cable to locate intermittents. An On/Off switch is provided, with an LED to indicate sufficient testing power. The included belt clip and compact durable casing ensure that you will be able to use this box anywhere.

#WHT  
**\$76<sup>50</sup>****BEHRINGER****CT100**

Tests XLR, mono, and TRS phone (1/4", 1/8", TT), RCA and MIDI connectors. It shows which input pin is connected to which output pin. Separate LED's indicate proper shield connection and phantom power presence. The CT100 also offers an

installed cable test mode, continuity check, and test-tone generator. This microprocessor-controlled device was designed to ensure fast, reliable problem location, and the included belt clip adds to its versatility.

#BECT100  
**\$29<sup>99</sup>****EBTECH****Swizz Army Cable Tester**

The Swizz Army Tester checks XLR, 1/4", RCA, 1/8", TT & MIDI cables for continuity and intermittent connections. Also detects opens and shorts for each pin. Other features include a test-tone generator (+4, -10, Mic), phantom power detector, grounded XLR shield detector, and cable wiring display. The display

LED's will also stay lit until reset, allowing you to catch intermittent faults that may have occurred too quickly to notice otherwise.

#EBSWIZZCT  
**\$89<sup>99</sup>****HOSA****CBT-375**

The CBT-375 is a one-button, automatic cable tester that makes verifying the continuity of your RCA, 1/4", 3.5mm, XLR, Speakon, and Banana connections quick and easy. Just plug one end of the cable into the right side of the tester, plug the other end of the cable into the left side and push the red button on top of the unit. The LED readout will give you a clear indication of your cable's status. Its durable construction will allow many hours of heavy use.

#HOCBT375  
**\$103<sup>95</sup>****WHIRLWIND****QBOX**

The Qbox is the all-in-one audio line tester ideal for applications such as live sound, maintenance, and installation work. It includes a microphone, a speaker, a test tone generator, outputs for standard headphones, a 1/4" jack for line-in or a 2k Ohm (telephone) earpiece out. A handy clip attaches the Qbox to your belt or equipment rack.

#WHQB  
**\$189<sup>95</sup>****ART****CableCOP**

The Cable COP provides testing for mic cables and patch cords with 2 or 3 conductors, instrument cables with 2 conductors, basic speaker cables with 2 conductors, and MIDI cables comprised of DIN5 connectors using 2 conductors. LED's on the CableCOP will only illuminate when the connected cable completes a circuit. As a result, you're able to tell immediately which cables need to be repaired. An LED may also fail to illuminate if a 3-conductor cable has been wired out-of-phase.

#ARCT  
**\$45<sup>00</sup>****WHIRLWIND****MCT-7**

This diagnostic cable tester has connectors for analyzing almost any type of cable combination. The convenient rotary switch allows testing of each conductor within the cable and can determine the internal wiring configuration. It tests NL4, 5 pin DIN (MIDI), BNC, XLR, TRS, RCA and 3.5 mm types with handy connector diagrams printed on the front panel to aid problem identification. With an all-metal housing, this unit is made for the rigors of heavy stage and studio use.

#WHMCT7  
**\$119<sup>95</sup>**



**AT8202** Selectable 10, 20, or 30dB attenuator in-line XLR barrel #AUAT8202.....**\$43.50**



**CP8201** Low-to-High Impedance Transformer XLR-F to 1/4"-M barrel #AUCP8201.....**\$19.95**



**A10Q, A20, A30** Pad w/ 10, 20, or 30dB attenuation in-line XLR barrels #PRMAX10, PRMAX20, PRMAX30 .....**\$34.95**



**FPSC0010B** Mic to Line Level in-line XLR barrel #PRLMX .....**\$34.95**



**FPSC0010B** Ground Lift in-line XLR barrel #PSAGL .....**\$27.55**



**FPSC0010D** Line to Mic Level Pad in-line XLR barrel #PSALMP .....**\$27.55**



**FPSC0010C** Phase Reversal in-line XLR barrel #PSAPR .....**\$27.55**



**A15LA** Line Output to Low Impedance Mic Input in-line XLR barrel #SHA15LA.....**\$34.95**



**9144PC** Low-to-High Impedance Transformer (150-15K Ohms), XLR-F to 1/4"-M barrel #PR9144PC .....**\$56.95**



**ITX** Isolation Transformer (for 600-Ohm Loads) in-line XLR barrel #PRITXMXF.....**\$57.50**



**PRX** Polarity Reverse in-line XLR barrel #PRPRX.....**\$32.95**



**GLX** Ground Lift in-line XLR barrel #PRGLX .....**\$32.95**



**A15PRS** Bi-Directional Polarity switch in-line XLR barrel #SHA15PRS.....**\$54.95**



**A15BT** Bridging Transformer matches balanced and unbalanced levels XLR barrel #SHA15BT.....**\$39.95**



**LTLIMP** Impedance Transformer in-line XLR-F to 1/4"-M barrel #VWHLTIMP.....**\$18.50**



**IMPHR** Phase Reverse in-line XLR Barrel #WHIMPHR.....**\$25.95**



**A15AS** Selectable 15, 20 or 30dB attenuator in-line XLR barrel #SHA15AS .....**\$38.50**



**A95U** Reversible Line Matching Transformer, XLR Male to 1/4" Phone Female #SHA95U .....**\$32.50**



**A85F** Low-to-High Impedance Mic Matching Transformer, XLR-F to 1/4"-M barrel #SHA85F .....**\$17.50**



**A95UF** Line Matching Transformer (for 75-300-Ohm Mics) XLR- F to 1/4"- F barrel #SHA95UF .....**\$34.95**



**MIT-156** Low-to-High Impedance Transformer In-Line XLR-F to 1/8" stereo mini-M, 18" #HOMIT156.....**\$19.95**



**CYX402** Stereo 1/8" Mini Male to 2 XLR Male, 6 ft. #HOYCSMM2XM6 .....**\$14.95**



**XLRJ2XLRP** XLR Female to 2 XLR Male Y-Cable, 18" #COYCXF2XM .....**\$22.99**



**XLRP2XLRJ** XLR Male to 2 XLR Female Y-Cable-18" #COYXM2XF.....**\$22.99**



**YPP308** Stereo 1/4" Female to 2 Stereo 1/4" Male-6" #HOYCSPF2SPM.....**\$5.95**



**YPR257** Stereo 1/4" Female to 2 RCA Male, 6" #HOYCSPF2RM .....**\$5.50**



**SPPS2PJC** Stereo 1/4" Male to 2 RCA Female, 6" #COYCSPM2RF.....**\$3.95**



**YMP137** Stereo 1/8" Mini Male to 2 Mono 1/4" Female, 6" #HOYCSMM2PF.....**\$5.50**



**YPP118** Stereo 1/4" Male to 2 Stereo 1/4" Female-6" #HOYCSPM2SPF6 .....**\$5.50**



**YPP136** Stereo 1/4" Female to 2 Mono 1/4" Male, 6" #HOYCSPF2PM .....**\$5.50**



**BNP116** Mono 1/4" to dual Banana, 6", (16 gauge) #HOAPF2B16.....**\$17.95**



**GSK116** Mono 1/4" to Speakon, 6", (16 gauge) #HOAPFS16.....**\$15.95**



**GPR104** 1/4" TS Phone Female to RCA Male  
#HOAPFRM ..... **\$2.95**



**SPPJ Mono** 1/4" Phone Male to RCA Phono  
Female #COAPMRF..... **\$2.09**



**GPP273** Stereo 1/4" Phone Male to Angled  
Stereo 1/4" Phone Female  
#HOASPMRASPF ..... **\$7.50**



**GPR123** Mono 1/4" Phone Male to Angled  
RCA Phono Female (pack of 2)  
#HOAPMRARF2 ..... **\$4.95**



**GPM103** Stereo 1/8" Mini Female to Stereo  
1/4" Phone Male #HOASMFSPM..... **\$2.95**



**GPP359** (1) Stereo 1/4" Male Phone to  
(2) Stereo 1/4" Female Phone  
#HOASPM2SPF ..... **\$3.95**



**GMP112** Stereo 1/8" Mini Male to Stereo  
1/4" Phone Female #HOASMMSPF..... **\$2.95**



**GPP290** Mono 1/4" Phone Male to Stereo  
1/4" Phone Female #HOAPMSPF..... **\$3.50**



**SPPMJ** Mono 1/8" Mini Female to Mono  
1/4" Phone Male #COAMFPM..... **\$1.29**



**GPP105** Stereo 1/4" Phone Female to Stereo  
1/4" Phone Female #HOASPFSPF ..... **\$3.50**



**SPPXLRJ** Mono 1/4" Phone Male to XLR  
Female Unbalanced #COAPMXF ..... **\$6.99**



**SPPXLRP** Mono 1/4" Phone Male to XLR  
Male Unbalanced #COAPMXM ..... **\$6.99**



**GXJ183** Stereo 1/4" Phone Female to XLR  
Female Balanced #HOASPFXF..... **\$12.50**



**XLRPSPJ** Stereo 1/4" Phone Female to XLR  
Male Balanced #COAPFXM..... **\$6.99**



**GXP143** Stereo 1/4" Phone Male to XLR Female  
Balanced #HOASPMXF ..... **\$11.95**



**GXJ235** Stereo 1/4" Phone Female to XLR  
Male Balanced #HOASPFXM ..... **\$9.95**



**XLRPPJ** RCA Phono Female to  
XLR Male Unbalanced #COARFXM ..... **\$6.99**



**XLRJPJ** RCA Phono Female to  
XLR Female Unbalanced #COARFXF..... **\$6.99**



**PPXLRP** RCA Phono Male to  
XLR Male Unbalanced #COARMXM ..... **\$6.99**



**PPXLRJ** RCA Phono Male to  
XLR Female Unbalanced #COARMXF..... **\$8.99**



**XLRJBL XLR** Female to XLR Female Balanced  
#COAXFXF ..... **\$8.99**



**XLRPBL** XLR Male to XLR Male Balanced  
#COAXMXM..... **\$6.99**



**GSK116** Mono 1/4" Phone Female to Speakon 6"  
#HOAPFS16 ..... **\$19.95**



**NL4MMXBULK** Speakon Female to Speakon Female  
#HOALSFSF ..... **\$9.95**



**COMPREHENSIVE**

**Audio Adapter Kit & Storage Case**

This audio adapter kit provides a pair of virtually every audio adapter in current use. The kit includes a sturdy plastic storage case with 10 compartments w/ adjustable dividers.

- |  |                               |  |
|--|-------------------------------|--|
| (2) Mini Female Stereo to Mini Female Stereo | (2) Mini Male to Phone Female | (2) Phono Female Stereo to XLR Male (Balanced) |
| (2) Stereo Mini Female to Stereo Phone Male  | (2) Mini Female to Phone Male | (2) Phone Female to XLR Male                   |
| (2) Phono Male Stereo to XLR Male (Balanced) | (2) Mini Female to RCA Male   | (1) Stereo Mini Male to 2 RCA Male (Y-Cable)   |
| (2) Phone Male to XLR Male                   | (4) Phone Male to RCA Female  | (1) Phono Male Stereo to 2 Phono Stereo Female |
| (2) Mini Female to Mini Female               | (2) Phone Female to RCA Male  |  |
| (2) RCA Male to XLR Female                   | (2) Phone Male to XLR Female  |  |
| (2) Mini Male to RCA Female                  | (2) XLR Female to XLR Female  |  |
| (4) Phone Female to Phone Female             | (2) RCA Female to XLR Male    |  |

#COAK  
**\$149<sup>95</sup>**



## SABRA SPK Kit

The Sabra-Som SPK is a complete shock mount and pop filter system including: the SPF pop filter, SSM-1 shock mount, and ST2 dual thread support. The SPF pop filter system is effective at eliminating noise caused by plosives, and the SSM-1 shock mount minimizes vibration-related noise.

#SASPK  
**\$109<sup>95</sup>**



## SABRA SPF Kit

The SPF system features two parallel pop filter rings mounted on an articulated arm for easy, sturdy positioning and placement. This flexible pop filter system is highly effective at eliminating breath noise and plosive sounds.

#SASPF  
**\$59<sup>95</sup>**



#POVAC6C  
**\$59<sup>95</sup>**



## POPLESS VOICE SCREENS

### VAC-6

The Popless Voice Screens VAC-6 is a pop filter/gooseneck combination with dual 6" windscreens for enhanced wind diffusion and pop suppression. It features a 15" gooseneck, and the position of each windscreen can be freely adjusted.

#POVACS 6  
**\$59<sup>95</sup>**



## POPLESS VOICE SCREENS

### VAC-s6

The VAC-s6 is a studio pop filter equipped with: a shock mount clamp, an adjustable 8" mini-gooseneck w/ screen holder, and (2) 6"-diameter screens. The VAC-s6 attaches to any microphone shock mount and its positioning is easily adjustable.

## POPLESS VOICE SCREENS

### VAC-RE20

The Popless Voice Screens VAC-RE20 is a pop filter designed for the Electro-Voice RE20 & RE27 broadcast microphones. It attaches to the Electro-Voice 309/A shock mount (required) and features a ball-and-socket joint for easy positioning.

#POVACRE20  
**\$44<sup>95</sup>**



## RAXXESS POMT

The POMT is a 6" STOP-IT pop filter with a flexible gooseneck and a steel stand clamp. The gooseneck allows for proper placement in front of microphones, and the steel clamp attaches easily to any microphone stand. The POMT is very effective at reducing plosives and breath noise in vocal performances.

#RAPOMT  
**\$24<sup>95</sup>**

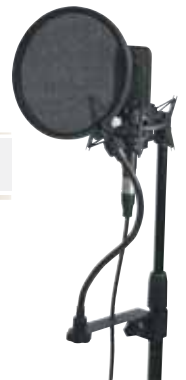

#SHPS6  
**\$29<sup>95</sup>**



## SHURE PS-6

The Shure PS-6 "Popper Stopper" is a pop filter/gooseneck combination that helps reduce noise due to plosive "p" and "b" sounds. It features a 6", 4-layer screen, and includes an adjustable metal gooseneck and a heavy-duty microphone stand clamp.

#SEPS  
**\$39<sup>00</sup>**



## SE ELECTRONICS Studio Pop Screen

The Studio Pop Screen's unique 5 1/4" metal screen is louvered at a slight angle to redirect ultra-low frequency breath blasts, and includes a flexible gooseneck arm and an adjustable stand clamp. The filter does not attenuate high frequencies (as fabric screens do), leaving vocal performances unaffected while reducing annoying low frequency "pops."



**WindTech Series 300** (black) 1 3/8" inside diameter, 1 7/8" depth, 25 colors #WI300.....**\$4.95**

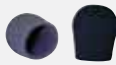

**WindTech Series 900** (black) 1 5/8" inside diameter, 2 1/8" depth, 22 colors #WI900.....**\$4.95**



**WindTech Series 600** (black) 1" inside diameter, 1 3/4" depth, 22 colors #WI600.....**\$4.50**

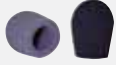

**WindTech Series 5700** (black) 1" inside diameter, 1 3/4" depth, 22 colors #WI5700.....**\$4.50**



**WindTech Series 1100** (black) 1/4" inside diameter, 3/4" depth, 22 colors #WI1100.....**\$3.95**



**WindTech Series 2300** (black) 3/16" inside diameter, Black or Off-white #WI2300.....**\$3.50**



**Tram BWS** windscreen for TR50 lavalier mic #TRBWS.....**\$12.49**



**Countryman E6 Windscreen** (beige) windscreen for E6 earset mic #COE6WSBE.....**\$5.95**



**Sony WS44** windscreen for ECM-44B lavalier mic #SOWS44.....**\$11.95**



**Sony WSU77S** foam windscreen for ECM-77 lavalier mic #SOWSU77S.....**\$9.99**

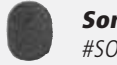

**Sony WSM77S** for ECM-77 lavalier #SOWSM77S.....**\$19.95**



**Sony ADR77B** metal windscreen (6 pack) #SOADR77B.....**\$94.95**



**Sennheiser MZW-66P** (black) velour-coated foam windscreen for ME-66 #SEMZW66P.....**\$64.95**



**WindTech BG-1** (black) 3/4" inside diameter, 7 1/4" depth #WIBG1.....**\$27.95**



**WindTech BG-2** (black) 3/4" inside diameter, 11 1/2" depth #WIBG2.....**\$33.50**



**WindTech BG-3** (black) 3/4" inside diameter, 20" depth #WIBG3.....**\$54.50**



**WindTech Series 1200** (black) 3/4" inside diameter, 1 5/8" depth, 22 colors #WI1200.....**\$4.50**



**WindTech Series 1300** (black) 5/8" inside diameter, 1 1/4" depth, 22 colors #WI1300.....**\$3.95**



**WindTech Series 1500** (black) 3/8" inside diameter, 3/4" depth, 22 colors #WI1500.....**\$3.95**



**WindTech Series 500** (black) 1/2" inside diameter, 1 1/4" depth, 22 colors #WI500.....**\$3.95**



**Rycote WindJammer** (black) furry windscreen for lavalier mics, also available: tan, gray, white #RYWFLB.....**\$25.00**



**Remote Audio MicroCat** (black) high-wind universal lavalier windscreen, also available: tan, gray, white #REMCATB.....**\$25.00**



**Audio Technica AT8116** for MT803 & MT831 lavalier mics #AUAT8116.....**\$9.50**



**Lectrosonics RK150** windscreen for M150 lavalier mic #LERK150.....**\$2.98**



**Sennheiser MZW-2F** foam windscreen for ME2 lavalier mic #SEMZW2F.....**\$5.00**



**Sennheiser MZW-2EW** metal windscreen for ME2 lavalier mic #SEMZW2EW.....**\$12.50**



**Shure A58WS** (black) foam windscreen for ball-type mics #SHA58WSBK.....**\$7.50**



**Shure A2WS** (black) locking foam windscreen for SM57 and 545 mics #SHA2WSBK.....**\$22.50**



**WindTech BG-60** (black) 1" inside diameter, 6" depth #WIBG60.....**\$27.95**



**WindTech BG-70** (black) 1" inside diameter, 11 1/4" depth #WIBG70.....**\$33.50**



**WindTech SG-1** (black) 3/4" inside diameter, 11 1/4" depth #WISG1.....**\$27.50**



**WindTech SG-2** (black) 3/4" inside diameter, 11 1/4" depth #WISG2.....**\$34.95**



**ON-STAGE****MY-251**#ONMY251  
**\$2<sup>95</sup>**

The MY-251 is a unique, elliptical-shaped clip designed to fit most brand name microphones. It has a 5/8"-27 female threaded brass insert and a black-finish base.

**WINDTECH  
MC4**#WINC4  
**\$5<sup>50</sup>**

The WindTech MC4 is an extra-large, heavy-duty wireless mic clip that holds most mics up to 1.75" in diameter, threading is brass inserted US standard 5/8"-27.

**ON-STAGE****MY-110**#ONMY110  
**\$4<sup>95</sup>**

The MY-110 is an unbreakable rubber mic clip designed for straight-style handheld wireless microphones. It has a 5/8"-27 female threaded insert in a black-finish plastic base.

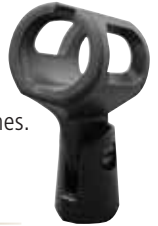
**ON-STAGE  
MY-100**#ONMY100  
**\$4<sup>95</sup>**

The MY-100 is an unbreakable rubber mic clip designed for tapered-styled dynamic microphones. It has a 5/8"-27 female threaded insert in a black-finish plastic base.

**ON-STAGE****MY-200**#ONMY200  
**\$4<sup>95</sup>**

The MY-200 is a spring-loaded clip designed to accommodate a variety of microphone sizes. It has a 5/8"-27 female threaded insert in a black-finish plastic base.

**ON-STAGE  
MY-250**#ONMY250  
**\$2<sup>95</sup>**

The MY-250 is an unbreakable rubber mic clip designed for tapered-styled dynamic microphones. It has a 5/8"-27 female threaded insert in a black-finish plastic base.

**SHURE****A53M**#SHA53M  
**\$37<sup>50</sup>**

The Shure Shock Stopper isolation mount/swivel adapter reduces transmission of mechanical noise and vibration.

**SHURE  
A55HM**#SHA55HM  
**\$34<sup>95</sup>**

Shure's Shock Stopper swivel adapter/isolation mount reduces transmission of noise and vibration, featuring a unique design allowing the mic to be snapped in and out without removing the cable.

**WINDTECH****PG-95**#WIPG95  
**\$6<sup>95</sup>**

The PG-95 is a pistol-grip shotgun microphone clip with a compact, lightweight design. It provides a female 5/8"-27 thread brass insert, and the mic clip angle is adjustable.

**ON-STAGE  
MY-325**#ONMY325  
**\$7<sup>95</sup>**

The MY-325 is a shock-mount mic clip designed to reduce the effects of low-end rumble. It has a 25mm opening for handheld dynamic microphones and a 5/8"-27 female threaded insert.

**ON-STAGE****MY-330**#ONMY330  
**\$7<sup>95</sup>**

The MY-330 is a shock-mount mic clip designed to reduce the effects of low end rumble. It has a 30mm opening for handheld wireless microphones and a 5/8"-27 female threaded insert.

**ON-STAGE  
MY-320**#ONMY320  
**\$7<sup>95</sup>**

The MY-320 is a shock-mount mic clip designed to reduce the effects of low end rumble. It has a 20mm opening for handheld condenser microphones and a 5/8"-27 female threaded insert.

**MIC-EZE****PIG-E-BAK**#MIPB  
**\$34<sup>95</sup>**

The MIC-EZE PIG-E-BAK double mic clamp mounts mics for dual feed and adjusts for phase cancellation. Dual vertical in-line clamp set with a swing type center attachment.

**Min-Eze**#MIMINEZE  
**\$36<sup>95</sup>**

The Min-Eze is an adjustable, dual perpendicular microphone clamp/clip with a trapeze-style center attachment. It features spring-action clamps with extra wide-opening jaws and protective clamp pads.

**ON-STAGE****MY-410**#ONMY410  
**\$23<sup>95</sup>**

The MY-410 is a universal shock mount designed to fit most large condenser microphones (42-48mm). Its die-cast steel adapter is fitted with female 5/8"-27 threads.

**MIC-EZE  
FE5**#MIFES  
**\$36<sup>95</sup>**

The FE5 is an adjustable microphone clamp featuring a 5" gooseneck with spring-loaded, lockable mounting clamps on each end. The clamps open to 2" wide.

**ATLAS  
TM-1**

#ATTM1  
**\$17<sup>50</sup>**

Twin microphone mounts provide for the horizontal attachment of two or three mics onto most stands, goosenecks, and stand adapters.



**ON-STAGE  
MY-500**

#ONMY500  
**\$10<sup>95</sup>**

The MY-500 is a 6" mic extension bar with a 5/8"-27 threaded knob for mounting standard mic clips, and an attachment bracket with tightening knob, to attach to a mic stand.



**K&M  
23500B**

#KM23500B  
**\$27<sup>50</sup>**

K&M fixed microphone support bar measures 8" across and accommodates 2 or 3 microphones.



**ON-STAGE  
MY-700**

#ONMY700  
**\$23<sup>95</sup>**

The MY-700 is a multi-use stereo bar designed to hold up to 6 microphones on 5/8"-27 threaded knobs. Its outside arms can be angled from 0 to 45 degrees.



**ON-STAGE  
MY-550**

#ONMY550  
**\$9<sup>95</sup>**

The MY-550 is a 6" mic extension bar with a 5/8"-27 threaded knob for mounting standard mic clips, and an attachment bracket with tightening knob, to attach to a mic stand.



**WINDTECH  
MPC-10**

#WIMPC10  
**\$14<sup>95</sup>**

The WindTech MPC-10 "C" type, multi-position clamp, fits 1.25" diameter tube or flat surface. The male 5/8"-27 thread insert rotates 90 degrees in three positions. Soft rubber insert prevents scratching.



**WINDTECH  
MA12**

#WIMA12  
**\$9<sup>95</sup>**

The MA12 is ideal for mounting mics to instruments, drums, brass and hard to reach areas and adapts to standard microphone holders.

**ATLAS  
CO1B**

#ATCO1B  
**\$18<sup>50</sup>**

The Atlas CO1B connect-on swivel adapter/clamp facilitates installation of a second mic to any floor or desk stand with 5/8" or 7/8" diameter tubing.



**ON-STAGE  
DM-01**

#ONDM01  
**\$5<sup>95</sup>**

The DM-01 is a clamp designed to securely attach a mic clip to a drum rim. It works with any 5/8"-27 mic clip (black finish).



**ON-STAGE  
DM-50**

#ONDM50  
**\$11<sup>95</sup>**

The DM-50 is a drum rim mic clip that dampens unwanted vibrations when miking drums. It fits 6"-18" drums with rims as tall as 1 3/8" (black powder-coat finish).



**WINDTECH  
DMC-2**

#WIDMC2  
**\$5<sup>50</sup>**

WindTech "C" clamp-style drum clamp, secures microphones to drums and many percussion instruments.

**CAD  
DSM1**

#CADSM1  
**\$19<sup>95</sup>**

The DSM1 is an anti vibration drum microphone mount designed to fit most lug-type drums. It features a quick-release design, rugged die-cast and steel construction.



**ON-STAGE  
TM02C**

#ONTM02C  
**\$3<sup>95</sup>**

The TM02C is a flange mount designed for mounting mic clips to flat surfaces. It has 5/8"-27 female threading, a chrome finish, and it includes mounting screws.



**TM02B** black finish version #ONTM02B ..... **\$3.95**

**ATLAS  
AD12BE**

#ATAD12BE  
**\$8<sup>95</sup>**

The Atlas AD12BE is a surface-mounting flange with a 5/8"-27 threaded fitting to accommodate goosenecks or microphone poles and microphone mounting hardware.



**TM08C**

#ONTM08C  
**\$4<sup>95</sup>**

The TM08C is a flange mount with a rubber base, designed for isolating mic clips from vibration and mounting them to flat surfaces. 5/8"-27 female threading, chrome finish.



**TM08B** black finish version #ONTM08B ..... **\$4.95**

**AUDIO-TECHNICA  
AT8601**

#AUAT8601  
**\$18<sup>95</sup>**

The Audio-Technica AT8601 microphone desk stand is compatible with 5/8"-27 threaded stand clamps.





**AUDIO-TECHNICA**  
**AT8646QM**

#AUAT8646QM  
**\$36<sup>95</sup>**



The Audio-Technica AT8646QM is an integrated mount, fitted with an XLR Female connector for lectern, pulpit, and conference table microphones.



**AUDIO-TECHNICA**  
**AT8416 Mic Shock Mount**

#AUAT8416  
**\$49<sup>95</sup>**

The Audio-Technica AT8416 shock mount effectively isolates mounted microphones from impact vibration and shock handling noise.

**ATLAS**  
**DS-2**

#ATDS2  
**\$27<sup>95</sup>**



The Atlas DS-2 is a desktop mic stand with a square, vibration-isolating base. The stand measures 4" in height and features a threaded pole that accommodates any standard microphone mount.



**ATLAS**  
**DS-5**

#ATDS5  
**\$11<sup>95</sup>**

The Atlas DS-5 is a fixed-height, desktop mic stand with a round cast-iron base that measures 5" high, accommodating any standard microphone mount.

**ATLAS**  
**DS-7**

#ATDS7  
**\$16<sup>50</sup>**

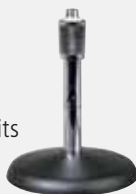

The Atlas DS-7 is a sturdy round-base table stand that is adjustable in height from 8-13 inches and fits all standard mic mounting hardware.



**K&M**  
**23110N**

#KM23110N  
**\$9<sup>95</sup>**

The K&M 23110N low-profile tabletop microphone stand offers sturdy, folding tripod legs and is compatible with standard microphone mounting hardware.

**ON-STAGE**  
**QK2-B**

#ONQK2B  
**\$12<sup>95</sup>**

The QK2-B is a quick-release mic adapter that allows you to quickly interchange a mic/mic clip with a touch of a button (black finish).



**ATLAS**  
**LO2B**

#ATLO2B  
**\$16<sup>50</sup>**



The Atlas LO2B is particularly useful for applications that require the quick removal of stand-mounted mics and features a secure, snap-on fastener and durable, push-button release.

**ON-STAGE**  
**DS7100B**

#ONDS7100B  
**\$6<sup>49</sup>**

The DS7100B is a non-adjustable, round-based desktop mic stand with a 4" fixed-height shaft and a 6" base. It is a great solution for basic tabletop applications.



**DS7200B**

#ONDS7200B  
**\$11<sup>95</sup>**



The DS7200B is a round-base desktop mic stand that is adjustable in height from 9"-13". This stand features a die-cast steel clutch, a removable shaft, and a 6" base. **DS7200C chrome version #ONDS7200C..... \$11.95**

**AKG**  
**ST305**

#AKST305  
**\$207<sup>95</sup>**

The ST305 is a cast-iron tabletop microphone stand with a Neoprene-layered shock-mounted base, measuring 6.25" in height, and accommodating all standard microphone mounting hardware.

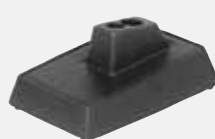

**SHURE**  
**S37A**

#SHS37A  
**\$26<sup>95</sup>**

The Shure S37A low-profile microphone desk stand is designed for use with various Shure swivel adapters and shock mounts, and has a non-reflective, gray-colored finish.

**ON-STAGE**  
**DS300B**

#ONDS300B  
**\$19<sup>95</sup>**

The DS300B is a mini boom desktop stand equipped with the innovative Posi-Lok clutch and a 6" diameter base. The Posi-Lok clutch features 52-locking teeth and an ergonomic knob.



**ON-STAGE**  
**MSA-9500**

#ONMSA9500  
**\$28<sup>70</sup>**



Includes: Posi-Lok clutch, 7", 13", 18" boom attachment, 5/8"-5/8" & 5/8"-7/8" connectors for desktop weighted bases.

**AUDIO-TECHNICA**  
**AT8459**

#AUAT8459  
**\$39<sup>95</sup>**

Audio-Technica 8459 Dual swivels provide an unlimited number of positions for exact mic placement; compatible with 5/8"-27 threaded stands.



**SHURE**  
**A27M**

#SHA27M  
**\$59<sup>95</sup>**



The Shure A27M is a stereo microphone adapter designed to hold two microphones in selectable positions for stereo broadcasting, recording, or sound reinforcement (ideal for flexible independent positioning).

**ATLAS**

**GN Series**

**Flexible Goosenecks**

The Atlas GN-6(E)/GN-13(E)/GN-19(E) are flexible goosenecks in 6", 13", and 19" lengths, respectively, attach to any microphone stand or adapter, and are available in chrome or ebony (E) finishes.

- GN19** #ATGN19.....**\$11.95**
- GN19E** #ATGN19E.....**\$11.95**
- GN13** #ATGN13.....**\$9.50**
- GN13E** #ATGN13E.....**\$9.50**
- GN6** #ATGN6.....**\$5.50**
- GN6E** #ATGN6E.....**\$5.50**



**ON-STAGE**

**MSA9030-06C**

#ONG6C  
**\$2.99**

The MSA9030-06C is a chrome-finish 6" gooseneck with 5/8"-27 male/female threads

**MSA9030-06B** black version #ONG6B.....**\$2.99**



**ON-STAGE**

**MSA9030-13C**

#ONG13C  
**\$4.95**

The MSA9030-06C is a chrome-finish 13" gooseneck with 5/8"-27 male/female threads.

**MSA9030-13B** black version #ONG6B.....**\$3.95**



**ATLAS**

**BE-E**

#ATBEE  
**\$18.50**

The B-EE is a two-section boom arm with an adjustable length of 24"-39", a metal swivel mount with 5/8"-27 threads (black).



**ATLAS**  
**PB21XE**

#ATPB21XE  
**\$43.95**

The PB21XE is an extendable-length boom arm with a fixed 3/4-lb counterweight. Its length is adjustable between 16 1/4"-24 1/2" (black).



**ON-STAGE**

**MSA7040TB**

#ONMSA7040TB  
**\$14.85**

The MSA7040 is a top-mounting, telescoping boom arm adjustable in length between 19"-32" (black).



**ON-STAGE**

**MSA7020B**

#ONMSA7020B  
**\$11.45**

The MSA7020B is a 32" fixed-length, top-mount boom arm (black).



**QUIK-LOK**

**A-113**

#QUA113BK  
**\$32.95**

The A-113 is a 30" fixed-length boom arm with a fast, non-slip boom swivel adjustment and a non-reflective, black enamel finish.



**QUIK-LOK**

**A-291**

#QUA291B  
**\$39.95**

The A-291 is a telescopic boom arm that adjusts from 22" - 40", with a non-slip boom swivel adjustment and a non-reflective, black enamel finish.



**ON-STAGE**

**MSA-9508**

#ONMSA9508  
**\$11.90**

The MSA-9508 is a 7" Posi-Lok mini-boom with a clamp style attachment for floor & desktop stands.



**ON-STAGE**

**MSA-9502**

#ONMSA9502  
**\$8.90**

The MSA-9502 is a Posi-Lok clutch with a 7" mini boom arm, in black finish.

**MSA-9503** 13" version #ONMSA9503.....**\$9.90**



**K&M**

**21110B**

#KM21110B  
**\$29.95**

The 21110B is a telescoping boom arm with counterweight that is adjustable between 18"-30" (black finish).



**K&M**

**21120B**

#KM21120B  
**\$32.95**

The 21120B is an extra-long telescoping boom arm with counterweight that is adjustable between 22"-38" (black finish).



**ON-STAGE**

**MA200**

#ONMA200  
**\$1.95**

The MA200 is a 5/8" male to 3/8" mic screw adapter for use with mic stands with European 3/8" threads.



**ON-STAGE**

**MA100**

#ONMA100  
**\$1.95**

The MA100 is a 3/8" male to 5/8" mic screw adapter for use with mic stands with European 3/8" threads.



**ULTIMATE-SUPPORT**

**MC05**

Round-Base Microphone Stand (black)

#ULMC05B  
**\$27<sup>99</sup>**

The Ultimate Support MC05 microphone stand features a cast-iron round base and an ergonomically-designed clutch for easy height adjustment from 34"-64".



**ULTIMATE-SUPPORT**

**MC-87**

Adjustable Microphone Stand w/Quick-Release Clutch

#ULMC87  
**\$49<sup>99</sup>**

The Ultimate Support MC-87 microphone stand features a quick-release clutch for easy adjustment. The stand is adjustable from 34"-64" and is uniquely designed to allow multiple stands to be stacked and stored effortlessly.



**ULTIMATE-SUPPORT**

**MC-97**

Tripod Microphone Stand w/Boom

#ULMC97  
**\$69<sup>99</sup>**

One-hand clutch and low-profile stackable base allow simple height adjustment and storage of up to six stands. 40"-60" adjustable height.



**ATLAS**  
**MS-10C**

Leader Stand Series Round-Base Microphone Stand

#ATMS10C  
**\$24<sup>95</sup>**

The Atlas MS10C (Chrome) Leader series microphone stand features a round cast-iron base with an adjustable height from 35"-63".



**ATLAS**  
**MS-25**

Heavy-Duty Triangular-Base Microphone Stand

#ATMS25  
**\$119<sup>95</sup>**

The Atlas MS-25 microphone stand features a triangular, cast-iron base for use on stage or broadcast. The stand is adjustable in height from 38"-67".



**ON-STAGE**  
**MS7201B**

Round-Base Microphone Stand

#ONMS7201B  
**\$21<sup>95</sup>**

The MS7201B is a round-base mic stand, adjustable from 34"-60" in height. It features a 9-lb sand-cast base, a steel mid-point locking clutch, and a black powder-coat finish. Base diameter: 10"

**MS7201C** chrome version  
#ONMS7201C..... **\$22.95**



**ON-STAGE**

**MS7600**

Hex-Base Mic Stand

#ONMS7600B  
**\$21<sup>95</sup>**

The MS7600 is a conventional threaded-shaft mic stand with an adjustable height of 34"-60". It features a low-profile design, a uniquely-shaped 9-lb base, and a black finish.



**ON-STAGE**

**MS7625B**

Hex-Base Quarter-Turn Mic Stand

#ONMS7625B  
**\$19<sup>95</sup>**

The MS7625B is a hex-base threadless microphone stand that is easily assembled or disassembled with a quarter-turn clockwise to lock, and a quarter-turn counter-clockwise to remove. It features a low-profile design and a uniquely-shaped 9-lb base.

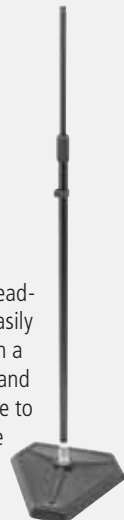

**ON-STAGE**

**MS7625PG**

Pistol-Grip Hex Mic Stand

#ONMS7625PG  
**\$34<sup>95</sup>**

The MS7625PG is a hex-base threadless microphone stand that is easily assembled or disassembled with a quarter-turn clockwise to lock, and a quarter-turn counter-clockwise to remove. It features a pistol grip on the top of the stand for one-handed height adjustment.

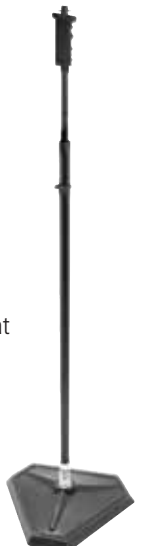



**ON-STAGE**

**MS7700B**

**Euro-Style Tripod Base  
Mic Stand**

#ONMS7700B  
**\$19<sup>95</sup>**

The MS7700B is an extremely stable tripod microphone stand with an adjustable height of 36"-63" and a base spread of 23". It features long foldable legs and a steel mid-point locking clutch.

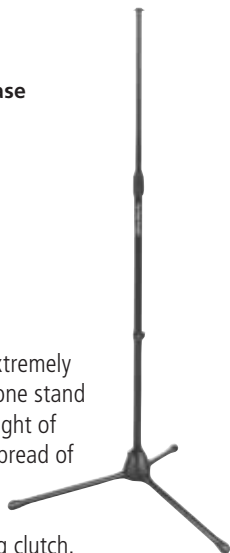

**QUIK-LOK**

**A-300**

**Tripod  
Microphone Stand w/  
Fixed Boom**

#QUA300  
**\$39<sup>95</sup>**

The Quik-Lok A-300 microphone boom stand features a sturdy tripod base with locking legs. The telescoping boom is adjustable in length from 30"-76.2" and the stand height is adjustable from 37.75"-65".



**ATLAS**

**TEB-B**

**Tripod Microphone  
Stand w/Boom**

#ATTEBE  
**\$34<sup>50</sup>**

The Atlas TEB-B a light-weight tripod microphone stand/ boom combo. The stand's height is adjustable from 37"-65", and the boom length between 24"-39" (black).



**K&M**

**21020B**

**Tripod  
Microphone  
Stand w/Boom**

#KM21020B  
**\$74<sup>95</sup>**

The K&M 21020B tripod microphone stand/boom provides lightweight, sturdy support for live sound and recording applications. It has a fixed-length, 32" boom, and its height is adjustable from 35.50"-65".



#ONMS7701B  
**\$28<sup>95</sup>**

**ON-STAGE**

**MS7701B**

**Euro Boom  
Microphone Stand**

The MS7701B is a foldable boom stand with an adjustable height of 36"-63", a boom length of 30" and a base spread of 23". It features a cast-steel mid-point clutch, high impact plastic leg housing, and a removable boom arm.

**MS7701TB adjustable-boom  
version (19"-33")  
#ONMS7701TB..... \$36.95**

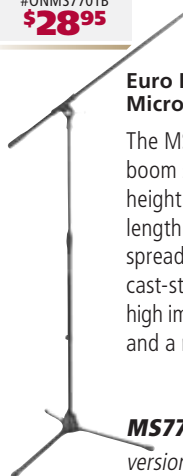

**QUIKLOK**

**A206B**

**Tripod with  
Telescopic Boom**

#QUA206B  
**\$79<sup>95</sup>**

The A206B is a heavy-duty tripod mic stand with an adjustable height of 37.75"-65.25". It features a telescoping boom arm (22"-40"), steel tubing, and high-grade hardware. Base spread: 27.5"

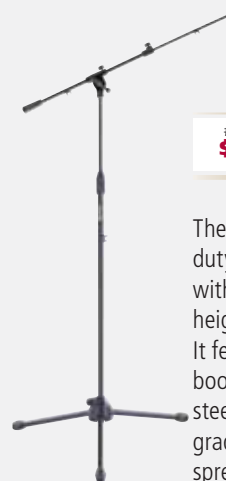

**SHURE**

**S15A**

**Tripod Floor Stand**

#SHS15A  
**\$157<sup>50</sup>**

The S15A is a lightweight tripod floor stand designed for portability. It features 5 telescoping sections with a height adjustable between 3.5 ft. and 14 ft. Carrying case included.



**ON-STAGE**

**SMS7650**

**Hex-Base  
Studio Boom**

#ONSMS7650  
**\$129<sup>95</sup>**

The SMS7650 is a heavy-duty studio boom with a 3-section vertical shaft that is adjustable in height from 38"-80". It features a 22-lb base with removable casters, a 79" boom arm w/counter weight, and a 7" mini-boom adapter.

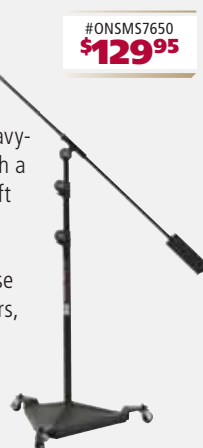

**ON-STAGE**

**SB96+**

**Studio Boom**

#ONSB96P  
**\$103<sup>95</sup>**

The SB96+ is a studio boom stand with a telescoping vertical shaft that is adjustable from 45"-76" in height. It features an extra long telescoping boom (43"-79") with a solid steel counterweight, a 40-tooth boom clutch, and a Posi-Lok mini-boom arm with mic clip.



**ON-STAGE****SS7730****Classic Speaker Stand**#ONSS7730  
**\$44.95**

The SS7730 is a steel/aluminum speaker stand with an adjustable height of 44"-80". It has a 1 3/8" diameter upper shaft (with a 1 1/2" adapter included), a base spread of 32"-48" and a weight capacity of 160 lbs (black).

**ON-STAGE****SS7761B****All-Aluminum Speaker Stand**#ONSS7761B  
**\$44.95**

The SS7761B is an all-aluminum speaker stand with an adjustable height of 44"-80". It has a reversible 1 3/8"-1 1/2" upper shaft (with locking safety pin), folding tripod leg, and a weight capacity of 120 lbs (black).

**ON-STAGE****SS7766****6-Position Speaker Stand**#ONSS7766  
**\$63.49**

The SS7766 Airhead is an aluminum tripod speaker stand equipped with a 6-position push-up locking system, and a pneumatic shock absorber in the center shaft. Its has an adjustable height of 40"-73" and a weight capacity of 100 lbs (black).

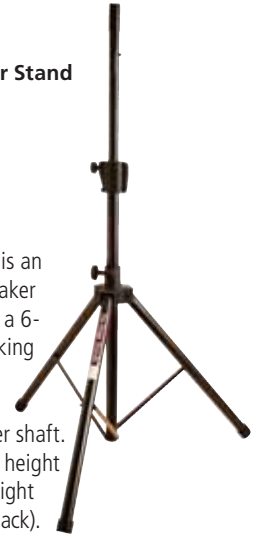
**ON-STAGE****SS8800B+****Power Crank-Up Speaker Stand**#ONSS8800BP  
**\$94.95**

The SS8800B+ is an aluminum tripod speaker stand that can be cranked up by hand or powered up by an electric or cordless drill (drill not included). It has an adjustable height of 47"-80" and a weight capacity of 100 lbs (black).

**ULTIMATE-SUPPORT****TS-80****6'7" Speaker Stand (silver)**#ULTS80S  
**\$79.99**

The TS-80 is a sound reinforcement speaker stand with adjustable height between 3'8" and 6'7". Its load capacity is 150 lbs and it weighs just 6 lbs 4 oz. The base diameter is 47" and it measures just 43.50" x 5.50" when folded.

**ULTIMATE-SUPPORT****TS-90****6'7" Speaker Stand w/Telelock collar (black)**#ULTS90B  
**\$99.99**

The TS-90 is a sound reinforcement speaker stand featuring the unique "TeleLock" collar (that allows one person to set up heavy speakers easily). It has an adjustable height between 3'8" and 6'7" and a load capacity of 150 lbs.

**ULTIMATE-SUPPORT****TS-88B****6'7" Speaker Stand (black)**#ULTS88B  
**\$109.95**

The TS-88B is a light-weight aluminum sound reinforcement speaker stand with an adjustable height between 5'2" and 6'7", and a load capacity of 150 lbs. Measuring 57.5" folded, the stand features a glass-reinforced telescoping collar and a die-cast metal collar clamp for maximum stability.

**ULTIMATE-SUPPORT****TS-99B****9'2" Speaker Stand (black)**#ULTS99B  
**\$129.95**

The TS-99B is a light-weight sound reinforcement speaker stand with an adjustable height from 5'2" to 9'2", and a load capacity of 150 lbs. The stand measures 57.5" folded, and features the "TeleLock" collar, allowing for easy one-person speaker setup.

**ON-STAGE****Mix-400****Autolocator/Mixer Stand**#ONMIX400  
**\$99.95**

The Mix-400 is a rolling stand designed for autolocators, mixers, and drum machines. It features a heavy-duty base with casters, a height-adjustable shaft and a completely adjustable (width & angle) top platform.



**ON-STAGE****MS7920B**

Bass Drum/Boom Combo

#ONMS7920B  
**\$19<sup>95</sup>**

The MS7920B is a low-profile, weighted-base boom stand designed specifically for miking kick drums. Its height is adjustable, and it features a 16" boom, a mid-point clutch, and heavy die-cast base.

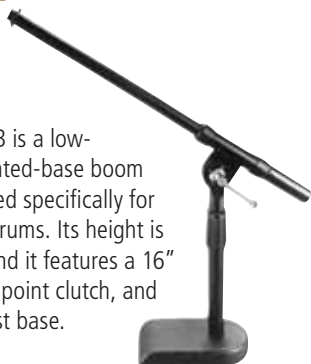
**ON-STAGE****MS7411B**

Drum/Amp Tripod w/Boom

#ONMS7411B  
**\$23<sup>75</sup>**

The MS7411B is a low-profile tripod boom stand designed for drum and amp cabinet miking applications. Its height is adjustable, and it features a 16" boom, a mid-point clutch, and folding legs.

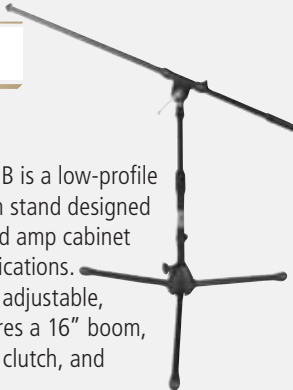
**ON-STAGE****MS7311B**

Kick Drum/Amp Stand

#ONMS7311B  
**\$25<sup>75</sup>**

The MS7311B is a weighted-base boom stand designed for miking kick drums and amp cabinets. Its height is adjustable from 8"-14", and it features a 17" boom, a mid-point clutch, and a die-cast base.

**K&M****25910B**

Tripod Microphone Stand w/Boom

#KM25910B  
**\$69<sup>95</sup>**

The K&M 25910B is a short tripod microphone stand/boom ideal for kick drum, bass, and guitar cabinet miking. It provides a fixed boom length of 21" and fixed height of 10.50".

**QUIK-LOK****BS-313**

Single-Brace, Low-Profile Amp Stand

#QUBS313  
**\$26<sup>95</sup>**

Adjustable, single-brace stand designed for small guitar, bass, keyboard amps, and combos. Height adjustment range: front tier 8.25-11", back tier 11.4-18.6"; depth range 11.8-15"; weight capacity 75 lbs

**QUIK-LOK****BS-317**

Double-Brace, Low-Profile Stand

#QUBS317  
**\$47<sup>95</sup>**

Adjustable, all-steel stand perfect for large guitar, bass, keyboard amps, and combos. Height adjustment range: front tier 8.25-11", back tier 11.4-18.6"; depth range 11.8-15"; weight capacity 100 lbs

**QUIK-LOK****QL-640**

Fully-Adjustable Amp Stand

#QUQL640  
**\$62<sup>95</sup>**

Full-circle, tilt-adjustable amp platform allows for exact amp positioning. Five height adjustment positions w/spring-loaded locking pin. Height adjustment range: 12.4"-24.8", depth range: 15.5"-23.7", weight capacity: 60 lbs

**ON-STAGE****KS7350**

Pro Heavy-Duty Folding-Z Stand

#ONKS7350  
**\$59<sup>95</sup>**

The KS7350 is a versatile keyboard stand with a weight capacity of 500 lbs. It allows for independent height or width adjustments and folds for easy storage. Applications: DJ, mixers and keyboards; height adjustment: 24"-38"

**ON-STAGE****KS7365EJ**

Pro Heavy-Duty Folding-Z w/2nd Tier

#ONKS7365EJ  
**\$116<sup>50</sup>**

The KS7365EJ is a heavy-duty, two-tier keyboard stand with a weight capacity of 400 lbs. Its height is adjustable between 28" and 36", and its width adjusts between 20" and 37".





**QUIK-LOK**

**QLX-22**  
Double-brace  
"X" Stand  
w/adjustable  
2nd Tier

#QUQLX22  
**\$97<sup>50</sup>**



The QLX-22 is a double-brace "X" style keyboard stand with adjustable second tier and unique "QLX RECALL" locking disc system. Load capacity: 200 lbs

**ULTIMATE-SUPPORT**

**IQ-1000**  
Single-Brace/Single-Tier  
"X" Stand

#ULIQ1000  
**\$49<sup>99</sup>**

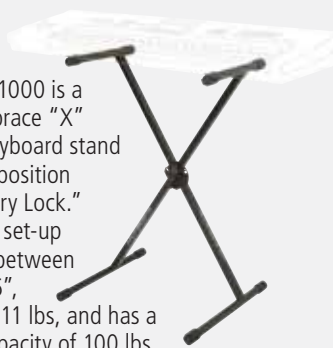

The IQ-1000 is a single-brace "X" style keyboard stand with 4-position "Memory Lock." It has a set-up height between 26.5-36", weighs 11 lbs, and has a load capacity of 100 lbs.

**ULTIMATE-SUPPORT**

**IQ-2000**  
Double-Brace/Single-Tier  
"X" Stand

#ULIQ2000  
**\$69<sup>99</sup>**

The IQ-2000 is a double-brace "X" style keyboard stand with 4-position "Memory Lock." It has a set-up height between 26.5 and 36", weighs 15 lbs, and has a load capacity of 150 lbs.



**ON-STAGE**

**KS8391**

Double-X Stand

#ONKS8391  
**\$29<sup>95</sup>**

The KS8391 is an adjustable height stand with a weight capacity of 200 lbs. It features double-X supports and the patent-pending quikSQUEEZE technology (5-position steel reinforced clutch and center hinge). Height adjustment: 27"-39"; base spread: 11"-30"

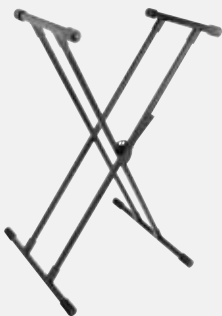

**ON-STAGE**

**KS8290**

Pro Heavy-Duty  
Single-X Stand

#OMKS8290  
**\$46<sup>95</sup>**

The KS8290 is a heavy-duty single-X stand with a weight capacity of 395 lbs. It features On-Stage's heaviest tubing, a 5-position ERGO-LOK clutch and Lok-Tight construction. Applications: large-format keyboards; height adjustment: 27"-39"; base spread: 11"-30"



**ON-STAGE**

**KS8291**

Pro Heavy Duty  
Double-X Stand

#ONKS8291  
**\$54<sup>95</sup>**

The KS8291 is a heavy duty double-X stand with a weight capacity of 395 lbs. It features On-Stage's heaviest tubing, a 5-position ERGO-LOK clutch, and Lok-Tight construction. Applications: large-format keyboards; height adjustment: 27"-39"; base spread: 12"-32"

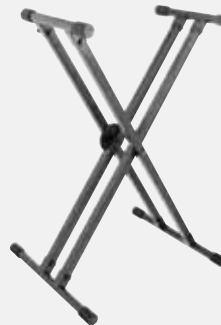

**ON-STAGE**

**KSA7500**

Universal 2nd Tier

#ONKSA7500  
**\$24<sup>95</sup>**



The KSA7500 is universal 2nd tier that includes an internal attachment to fit any keyboard stand with either 1" or 30mm round or square tubing. Weight capacity: 60 lbs

**ULTIMATE SUPPORT**

**VS-80B**

V-Stand

#ULVS80  
**\$179<sup>99</sup>**

The VS-80B is a versatile keyboard, DJ equipment & console stand ideal for live performances requiring quick setup and tear-down. It has a load capacity of 250lbs, fully adjustable height of 24.5" - 41.5" and folds into a compact 28 x 9.5 x 6" (black).



**ULTIMATE SUPPORT**

**Apex AX-48B**

Column Keyboard Stand

#ULA  
**\$189<sup>99</sup>**

The AX-48B is a 46" column keyboard stand designed for live performance. This dual-tier stand has a load capacity of up to 125 lbs. per tier and folds into a self-contained, compact unit with a heavy-duty carrying handle (black).



**AX-48S** matte-silver finish version  
#ULAX48S..... **\$189.99**

**ON-STAGE**  
**SM7122B**

#ONSM7122BB  
**\$13<sup>95</sup>**

The SM7122B is a compact sheet music stand with a two-section telescoping shaft and a cam-lock clutch. It can be used sitting or standing, and the tripod leg assembly folds up for storage (black).

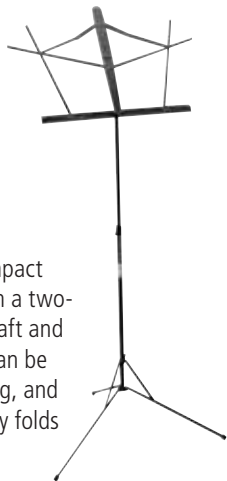

**SM7122N** nickel-finish version  
#ONSM7122NB .....**\$9.95**

**ON-STAGE**  
**SM7611B**

#ONSM7611B  
**\$43<sup>95</sup>**

The SM7611B is a hex-based conductor's stand with an adjustable height of 32"-48" (clutchless). It features a tilting 13 1/2x19" bookplate with a 2" lip and a 12" base.



**ON-STAGE**  
**SM7211B**

#ONSM7211B  
**\$45<sup>95</sup>**

The SM7211B is a tripod-based conductor's stand with an adjustable height of 25"-45". It features a mid-point clutch and a tilting 13 1/2x19" bookplate with a 2" lip.



**ON-STAGE**  
**KT7800**

**3-Position X-Style Bench**

#ONKT7800  
**\$29<sup>95</sup>**



The KT7800 is an affordable bench designed for studio or home use, with a weight capacity of 300 lbs. It features a 2" padded

covered seat and folding legs. Bench seat size: 12x17"; 6 adjustable height positions

**ON-STAGE**  
**KT7800+**

**Deluxe X-Style Bench**

#ONKT7800P  
**\$49<sup>95</sup>**



The KT7800+ is a deluxe keyboard bench designed for comfort, and a weight capacity of 360 lbs. It features a 3" cushion seat, folding legs, and

a spring-loaded, double-deadbolt locking system. Bench seat size: 12-1/2x23-1/2"; 8 adjustable height positions

**ON-STAGE**  
**KSB6500**

**Folding Z and Platform Stand Carry Bag**

#ONNKS6500  
**\$28<sup>25</sup>**



The KSB6500 is a heavy-duty carry bag designed

for folding Z and platform keyboard stands. It is made of a padded nylon material, and provides 2 hand straps, 2 internal Velcro straps, and a center length-wise double zipper. Dimensions: 30x16x8.75"

**CASIO**  
**PBench**

#CAPBO  
**\$39<sup>95</sup>**



The PBench is capable of holding up to 250 pounds and folds flat for easy portability. The padded black seat cushion makes this portable bench comfortable as

well as attractive; it's the perfect complement to your digital piano or keyboard.

**YAMAHA**  
**PKBB1**

#YAPKBB1  
**\$39<sup>95</sup>**



The PKBB1 offers lasting comfort and a reputation as one of Yamaha's top-selling benches. Its ultra-thick padding and extra-wide single seat assures the utmost comfort for hours of music enjoyment. With a

definitive black finish and a soft padded seat, this bench is fully adjustable for individual comfort, and folds up for your traveling convenience.

**GATOR CASES**  
**GX-33**

**Mic Stand Bag**

#GAGX33  
**\$34<sup>99</sup>**



The GX-33 is a rugged microphone stand bag with 3 separate compartments for mic stands and 5 form-fitted mic drops. It is constructed of 600-denier nylon and provides 2 webbed handles & an adjustable shoulder strap. Dimensions: 55x8.5" diameter

**RAXXESS**

**Elite Speaker Stands**

ERSS-42's are studio monitor stands constructed of fused melamine with a fixed height of 42". They have 14"-square platforms and bases, dual-cable management ducts, and feature contrasting silver trim (pair).



**ESS-42BSL** ebony finish #RAESS42BSL.....**\$229.95**  
**ESS-42MSL** maple finish #RAESS42MSL.....**\$229.95**

**ON-STAGE**

**SM6000-P**

Adjustable Studio Monitor Stands

#ONSM6000P  
**\$84.95**



The SM6000-P is a studio monitor stand with an adjustable height of 36"-52" and a 9"-square top platform. Its 3-point triangular base is equipped with leveling spikes and its weight capacity is 90 lbs (pair).

**RAXXESS**

**Economy Speaker Stands**



ERSS's are studio monitor stands constructed of 3/4" furniture-grade hardboard and finished in a black oak laminate. The speaker platform and base are 12" square (pair).

**ERSS-36 36"** version #RAERSS36 ....**\$134.95**  
**ERSS-42 42"** version #RAERSS42 ....**\$139.95**

**SAMSON**

**MS-200**

#SAMS200  
**\$69.00**



MS-200's are professional-grade isolated studio monitor stands with a telescoping column (adjustable from 30"-50"), a solid metal speaker platform and heavy base with carpet spikes. 40 lbs maximum speaker load (pair)

**MS-100** #SAMS100 ..... **\$59.00**

**RAXXESS**

**Graphite Group Speaker Stands**

The GRFSS42 is a pair of studio monitor speaker stands made of medium-density fiberboard with a vinyl brushed-aluminum finish. The speakers are 42" in height, feature a 5"-square center post, and measure 14" square at the base, which is equipped with rubber floor bumpers (pair).

#RAGRFSS42  
**\$204.95**



**ULTIMATE SUPPORT**

**MS-45B2**

#ULMS45B2  
**\$188.95**

Aluminum Studio Monitor Stands MS-45B2's are aluminum studio monitor stands with a fixed height of 45" and a 9"-square top plate. They have a triangular metal spiked base, a streamlined cable management system, and a weight capacity of 75 lbs (pair).



**MS-36B2 36"** version #ULMS36B2.....**\$174.95**

**QUIKLOK**

**BS-342**

Heavy-Duty Monitor Stand

#QUBS342  
**\$139.95**

BS-42's are heavy-duty monitor stands with a tri-support design, adjustable leveling floor spikes, and a fixed height of 42". They have 11" rubber padded square top plates, integrated cable management, and a weight capacity of 125 lbs (pair).



**BS-336 36"** version #QUBS336.. **\$129.95**

**MIDDLE ATLANTIC**

**Edit Center Speaker Stands**

Edit Center Speaker Stands are 36" fixed height monitor stands featuring high-mass all wood construction, unique dual cable channels and reversible speaker platforms & bases (graphite or cherry wood). Include both carpet spikes and rubber feet. (pair)

#MIECSPK36  
**\$399.95**





**OMNIMOUNT PRO**  
**WB Series**

WB Series mounts are designed to support enclosures of limited strength as a bottom mount or virtually invisible mount when attached to the top of an enclosure. These mounts provide a wide range of vertical and horizontal movement.

**Wall to bottom/top of the enclosure**  
*Available in black or white*

- WB 20.5** for enclosures up to 20.5 lbs; black #OM205WBB, white #OM205WBW..... **\$39.95**
- WB 30.0** for enclosures up to 30 lbs; black #OM300WBIFKB, white #OM300WBIFKW... **\$76.95**
- WB 60.0** for enclosures up to 60 lbs; black #OM600WBB, white #OM600WBW..... **\$89.95**



- WB 120.0** for enclosures up to 120 lbs; black #OM1200WBB, white #OM1200WBW..... **\$129.50**



**OMNIMOUNT PRO**  
**WBX Series**

WBX mounts are WB mounts that provide a longer reach from the wall. The supporting tube is approximately 25% longer and 25% larger in diameter than the WB. It is used for larger enclosures needing more rotation for proper coverage.

**Wall to bottom/top of the enclosure (extended)**  
*Available in black or white*

- WBX 30.0** for enclosures up to 30 lbs  
black #OM300WBXB, white #OM300WBXW..... **\$69.95**
- WBX 60.0** for enclosures up to 60 lbs  
black #OM600WBXB, white #OM600WBXW ..... **\$88.95**
- WBX 120.0** for enclosures up to 120 lbs  
black #OM1200WBXB, white #OM1200WBXW ... **\$137.50**

**OMNIMOUNT PRO**  
**WA Series**

WA mounts provide a more limited range of vertical and horizontal movement, but have less visual impact on the room environment. For enclosures having footings at the back of the enclosure, the WA is the best mounting solution for the widest coverage.

**Wall to back of the enclosure**  
*Available in black or white*

- WA 20.5** for enclosures up to 20.5 lbs  
black #OM205WAB, white #OM205WAW..... **\$39.95**
- WA 30.0** for enclosures up to 30 lbs  
black #OM300WAIFKB, white #OM300WAIFKW..... **\$69.95**
- WA 60.0** for enclosures up to 60 lbs  
black #OM600WAB, white #OM600WAW ..... **\$89.95**
- WA 120.0** for enclosures up to 120 lbs  
black #OM1200WAB, white #OM1200WAW ..... **\$129.50**



**QUIKLOK**  
**QL-30**

**Speaker Wall Mount**

The QuikLok QL-30 is a speaker wall mount with a 2-hole speaker plate, a 4-hole wall plate, and a front-to-back depth of 4.75"; an ideal mounting solution for all types of commercial installation applications.

#QUQL30  
**\$59.95**

- 30-lb weight capacity
- Perfect for homes, stores, theaters, churches, and all kinds of commercial applications
- Heavy-duty, arc-welded steel construction
- Standardized mounting holes fit most popular speakers
- Tilt-and-swivel adjustable for exact directional positioning
- Non-reflective black enamel finish

- QL-30E** 4-hole speaker plate & 4-hole wall plate #QUQL30E ..... **\$69.95**
- QUQL60** 60-lb capacity, 4-hole speaker plate & 3-hole wall plate #QUQL60 ... **\$64.95**



**QUIKLOK**  
**QL-90**

**Tilt-Adjustable Speaker Wall Bracket**

The QuikLok QL-90 is a tilt-adjustable speaker wall bracket for speaker cabinets with 1-3/8" mounting hole with a distance from wall of 14.3".

- 75 lbs weight capacity (if stud mounted)
- Full tilt and side-to-side adjustment
- All-Steel Construction
- Available in black or white
- Optional corner mounting plate available (QL-90CK)

#QUQL90  
**\$57.95**



**ON-STAGE**  
**SS 7913B**

**Wall-Mount Speaker Bracket**

SS7913B is a wall-mount bracket designed for mounting speaker cabinets with 1 3/8" or 1 1/2" bottom mounting holes. Ideal for sound contractors, night clubs, and schools.

- 100 lbs weight capacity
- Applications: Small speaker cabinets
- Rectangular tubing
- Includes: screws for assembly, 1 3/8"- 1 1/2" adapter sleeve

#ONSS7913B  
**\$54.95**  
*per pair*

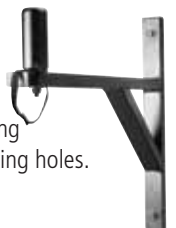

**K-TEK**

Model	Material	Sections	Cabling	Max. Ext	Min. Ext	Weight	#SKU	Price
KE69CC	Aluminum	3	Coiled	5.9'	2.5'	1.1 lbs	#KTKE69CC	<b>\$149.95</b>
KE79	Aluminum	6	None	6.5'	1.6'	1.2 lbs	#KTKE79	<b>\$174.95</b>
KE79CC	Aluminum	6	Coiled	6.5'	1.6'	1.4 lbs	#KTKE79CC	<b>\$209.95</b>
KE110CC	Aluminum	5	Coiled	9.2'	2.5'	1.8 lbs	#KTKE110CC	<b>\$229.95</b>
KE100	Carbon Fiber	5	None	8.9'	2.2'	1.0 lbs	#KTKEG100	<b>\$309.95</b>
K102	Carbon Fiber	5	None	8.9'	2.2'	1.2 lbs	#KTK102	<b>\$399.95</b>
KE100CC	Carbon Fiber	5	Coiled (bottom exit)	8.9'	2.2'	1.3 lbs	#KTKEG100CC	<b>\$408.95</b>
K56CC	Carbon Fiber	5	Coiled (bottom exit)	4.1'	1.4'	1.0 lbs	#KTK56CC	<b>\$474.95</b>
K102CC	Carbon Fiber	5	Coiled (bottom exit)	8.9'	2.2'	1.2 lbs	#KTK102CC	<b>\$534.95</b>
K102CCR	Carbon Fiber	5	Coiled (side exit)	8.9'	2.2'	1.6 lbs	#KTK102CCR	<b>\$564.95</b>
K152CC	Carbon Fiber	5	Coiled (bottom exit)	12.8'	3.0'	1.8 lbs	#KTK152CC	<b>\$659.95</b>
K152CCR	Carbon Fiber	5	Coiled (side exit)	12.8'	3.0'	2.0 lbs	#KTK152CCR	<b>\$689.95</b>
K202CC	Carbon Fiber	5	Coiled (bottom exit)	16.1'	3.1'	2.2 lbs	#KTK202CC	<b>\$779.95</b>
KA113CCR	Carbon Fiber	6	Coiled (side exit)	9.5'	1.4'	1.9 lbs	#KTKA113CCR	<b>\$799.95</b>

**BEYERDYNAMIC**

Model	Material	Sections	Cabling	Max. Ext	Min. Ext	Weight	#SKU	Price
MZA717	Aluminum	3	None	5'	2'	0.7 lbs	#BEMZA717	<b>\$108.95</b>
MZA718	Aluminum	4	None	10.5'	3'	1.9 lbs	#BEMZA718	<b>\$163.95</b>

**LIGHTWAVE**

Model	Material	Sections	Cabling	Max. Ext	Min. Ext	Weight	#SKU	Price
A-5	Aluminum	5	None	8.2'	2.2'	1.4 lbs	#LIA5N	<b>\$150.00</b>
A-5CC	Aluminum	5	Coiled	8.2'	2.2'	1.7 lbs	#LIA5CCN	<b>\$236.00</b>
G5	Carbon Fiber	5	None	8.2'	2.2'	0.95 lbs	#LIG5	<b>\$299.00</b>
G5CC	Carbon Fiber	5	Coiled	8.2'	2.2'	1.2 lbs	#LIG5CC	<b>\$385.00</b>

**PSC**

Model	Material	Sections	Cabling	Max. Ext	Min. Ext	Weight	#SKU	Price
FBPSCC	Carbon Fiber	5	Coiled	6.1'	1.7'	0.7 lbs	#PSSBPCC	<b>\$454.58</b>
FBPMCC	Carbon Fiber	5	Coiled	8.3'	2.2'	0.9 lbs	#PSMBPCC	<b>\$498.75</b>
FBPLCC	Carbon Fiber	5	Coiled	12.4'	3'	1.2 lbs	#PSLBPCC	<b>\$618.95</b>
FBPXLSC	Carbon Fiber	5	Straight	17.3'	4.3'	1.7 lbs	#PSXLPSC	<b>\$755.25</b>



**BOOM AUDIO**  
**Kit Cool**

The Kit Cool is a unique device that allows a boompole to be supported by one hand, reducing arm/back strain and fatigue, while freeing the other hand to operate the mixer. It features a cradle made of foam-covered rollers, allowing the boom to be moved in all directions without vibration. The 3-section telescopic support pole is adjustable from 550–1100 mm with an innovative and effective 1/4-turn clutch; simply adjust to the correct height, then twist the vertical markers into alignment to lock.



#BOKCS  
**\$452<sup>25</sup>**

**BOOMMATE**  
**Boompole Cradle**

The BoomMate boompole holder attaches to Avenger/Mathews grip heads for stationary mounting of boompoles to lighting or C-stands. It allows hands-free use of boompoles for fixed applications and single-man operations.



#BOBPH  
**\$64<sup>95</sup>**



**K-TEK**  
**K-HGW**

The K-HGW consists of a K-Tek boompole head, 6" of K-Tek boom-pole graphite covered with foam, and a male XLR connector with two female 3/8"-16 mounting threads. The grip is internally wired with soft cloth-covered quiet cable and fitted with the K-Tek short profile Female XLR microphone connector.

#KTKHGW  
**\$92<sup>95</sup>**

**RYCOTE**  
**Softie Mount & Pistol Grip**

The Softie Mount & Pistol Grip allows handheld operation of shotgun microphones or boompole mounting with the 3/8" threading at the base of the grip. It features a medium-sized hole that accommodates microphones with 21-22mm (.83-.87") diameters.



#RYMPGM  
**\$119<sup>00</sup>**

**Also Available** Small hole version 19–20mm #RYMPGS... **\$119.00**  
Large hole version 24–25mm #RYMPGL... **\$119.00**

**PEARSTONE**  
**Grip**

The Grip is a universal foam-padded handle with a 3/8"-16 (male) threaded adapter (boompole standard), and a threaded base (female) for attachment to a boompole. It allows handheld use of a PSC mount, Audio-Technica AT8415 etc., with increased isolation from handling noise.



#PEGRI  
**\$34<sup>95</sup>**

**AUDIO-TECHNICA**  
**AT8415**

The 8415 is a lightweight, low-profile microphone shock mount with a removable interior thread adapter. It is designed for 19-25mm diameter microphones and is compatible with 3/8"-16 and 5/8"-27 threaded stands.



#AUAT8415  
**\$49<sup>95</sup>**

**AT8415 Deluxe** features high-quality K-Tek K-SUS suspenders  
#AUAT8415D..... **\$64.95**



**SENNHEISER**  
**Blimp System**

The Blimp System consists of three components: a combination shock mount/pistol grip/stand adapter, a rigid blimp windshield, and a long hair wind muff. It provides excellent shock isolation and wind protection, and is available in different sizes to accommodate a variety of microphones.

- MZS 20-1 Pistol Grip**  
#SEMZS201..... **\$643.50**
- MZW60-1 Blimp Windshield**  
#SEMZW601..... **\$309.95**
- MZH60-1 Long Hair Wind Muff**  
#SEMZH601..... **\$199.95**

**RYCOTE**  
**Softie**

The Softie Windshield is a slip-on, open cell foam with an integral fitted fur cover. This location sound standard reduces wind noise and helps protect your microphone. It provides a fast, flexible and cost-effective solution for a wide selection of ENG/EPF microphones.



Shown 18cm Medium Hole

Available in 12, 18, 24, 29 and 32cm lengths and three different diameters (small, medium and large hole).

#RYS18M  
**\$110<sup>00</sup>**



**WHIRLWIND**

**PressMite**

**Active Press Box**

The Pressmite is a compact, active press feed distribution box that distributes 12 high-quality mic level signals and 2 line level signals with a high degree of isolation between outputs. It features a built-in headphone amp, 60dB input gain adjustment, and 8 hours of continuous operation via two 9V batteries.



#WHPM  
**\$819<sup>95</sup>**

**WHIRLWIND**

**PressPower 2**

**Active Press Box**

The PressPower 2 is a high-performance press conference standard. It features two mic/line inputs with individual gain controls and 16 transformer isolated outputs that are individually switchable for mic or line level operation. The unit can be powered by 115/230VAC, (4) 9V batteries, or external DC supply (12-36VDC).



#WHPP2  
**\$1599<sup>95</sup>**

**WHIRLWIND**

**PB Series**

**Passive Press Boxes**

The PB Series are passive units that distribute one line level input to multiple mic level outputs. Each output is transformer isolated, providing excellent inter-channel isolation.



- PB6** 6 outputs #WHPB06..... **\$289.95**
- PB12** 12 outputs #WHPB12.... **\$414.95**
- PB24** 24 outputs #WHPB24... **\$748.50**

**PSC**

**Press Bridge**

**Active Press Box**

The Press Bridge is a 3-input/12-output audio distribution box designed for press conference applications. It features two microphone level and one line level input (each with independent level controls), an internal tone oscillator and 12 transformer isolated outputs. Provides more than 12 hours continuous use from (2) 9V batteries.



#PSPB  
**\$1125<sup>75</sup>**

**LPB COMMUNICATIONS**

**SB-215**

**Silent Boom Retractable Boom Arm (30")**

The SB-215 (silent boom) is a retractable microphone boom arm designed for professional radio broadcast applications. The boom features flocked springs and an extruded, solid aluminum frame that virtually eliminates handling noise. It will hold up to 7 lbs and has a reach of up to 30".

- SB-R3** 3" riser for silent boom #LPSBR3..... **\$24.95**

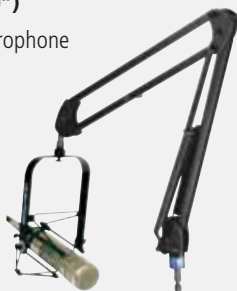

#LPSB215  
**\$129<sup>95</sup>**

**O.C. WHITE**

**61900BG**

**ProBoom Elite (Black/Gold)**

The 61900BG is an easily adjustable, heavy-duty microphone boom arm mounting system designed for on-air broadcast or voice-over applications. It offers a noise-free dual retracting/expanding spring-loaded arm for strong, secure microphone positioning, integrated wire extension/connector, and a 15" riser that secures to any desk-top surface using the mounting flange (or optional mounting clamp).

- 14005B** 2" microphone arm table clamp #OC14005B..... **\$24.95**

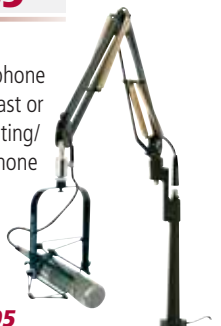

#OC61900BG  
**\$169<sup>95</sup>**

**DENECKE**

**GR-1**

**Master Clock Time Code Generator/Reader**



The GR-1 is a precision time code generator/reader designed for production sound recording. The GR-1 can be used as a stand-alone master time code source in most recording environments.

- Generates time code at 23.976, 24, 25, 29.97, 30 fps, drop & non drop
- Displays time code/user bits & mode on LCD backlit screen
- Jam syncs to external code and can cross jam different code rates
- Serial printer can be connected to make time code logs
- Powers via: 6 AA batteries or 24v DC external power

#DEGR1  
**\$979<sup>95</sup>**

**KATAMOUNT**

**Scriptlinc**

**Time Code Logging System**



The Scriptlinc is a UHF wireless time code logging system consisting of a small transmitter and a clipboard receiver with a large LCD screen. Time code is sent to the clipboard via the transmitter, where it can be frozen by the 2 hold buttons for logging time code information in the script log. It powers via 4 AAA batteries for up to 36 hours of continuous use.

#KASL433  
**\$1150<sup>00</sup>**

**AMBIENT AUDIO**

**ACD-301**

**Master Slate**

The ACD-301 Master Slate is a timecode reader/writer/clapper with four different display modes: Generator, Generator with internal real-time clock, Reader/Generator, and pure Reader. The Reader/Generator mode displays external code when the slate is open and internal generator code is displayed on closing.



#AMACD301  
**\$1459<sup>95</sup>**

**ACD-301 RF** UHF wireless Master Slate #AMACD301RF...**\$1695.00**

**AMBIENT AUDIO**

**ACC-501**

**Controller Master Clock**

The ACC-501 is a highly accurate portable master clock and time code generator/reader; it can jam, read, identify, and compare all time codes. This device supports many frame rates and frame rates can be changed to match equipment units to one another using jam-syncing.



#AMACC501  
**CALL**

- Designed for film & broadcast applications
- Portable master clock & time code generator/reader
- Supports all frame rates • Accuracy check, crystal tuning & GPS time
- Powers via: 6 AA batteries • Includes LEMO-5 cable

**DENECKE**

**TS-C**

**Time Code Slate**



The TS-C is a compact, full-featured smart slate, capable of reading, generating, and displaying SMPTE/EBU time code. This affordable slate jams to all standard frame rates (including 23.976 for HD), and its 16-bit microprocessor ensures extremely low drift. The standard EL backlit face plate is helpful in low-light situations. Aaton serial communication is provided via 5 pin Lemo plug.

#DETS3  
**\$1149<sup>00</sup>**

**DENECKE**

**TS-3**

**Time Code Slate**



The TS-3 is a time code slate with an internally-mounted SB-2 Syncbox Time Code Generator. It reads and displays SMPTE/EBU time code, and jams to all standard frame rates, including 30 df. Its high stability TCXO (Temperature Compensated Crystal Oscillator) ensures low drift in extreme temperature ranges (color clappers).

#DETS3  
**\$1195<sup>00</sup>**

- TS-3BW** with black & white clappers #DETS3BW.....**\$1195.00**
- TS-3EL** with EL backlight display #DETS3EL .....**\$1359.95**

**JK AUDIO**

**CellTap**

**Wireless Phone Headset Jack**

The CellTap is a telephone audio interface that connects between the 2.5mm earpiece jack of your cell phone and your earpiece or headset. Simply connect a tape recorder or powered speakers to the 1/8" mini jack for audio recording and telephone conferencing.



#JKCELLTAP  
**\$78<sup>95</sup>**

**JK AUDIO**

**QuickTap**

**Telephone Handset Tap**

The QuickTap is a simple, passive telephone tap designed for capturing telephone conversations. It features a mono 1/8" mini output that can be used to send a mix of both sides of a conversation to recording devices, amplifiers, etc. The QuickTap is lightweight, portable, and requires no external power.



#JKQT  
**\$58<sup>95</sup>**

**JK AUDIO**

**THAT-1**

**Telephone Interface with RCA**



The THAT-1 is an audio interface that connects between the telephone receiver and base. It is designed to capture audio and play back sound over telephone lines. The compact telephone tap features RCA I/O and a dedicated output volume control.

#JKT1  
**\$134<sup>95</sup>**

**JK AUDIO**

**THAT-2**

**Telephone Interface with XLR I/O**



The THAT-2 is a telephone audio interface that connects between the telephone receiver and base. It is designed to capture audio and play back sound over telephone lines. The compact telephone tap features XLR and RCA I/O and input & output volume controls.

#JKT2  
**\$199<sup>95</sup>**

**JK AUDIO****Broadcast Host****Desktop Digital Hybrid**

The Broadcast Host is an affordable digital hybrid telephone interface designed for desktop broadcast applications. It provides excellent separation of caller and talent voices, 16-bit DSP technology and Auto-Answer/Auto Disconnect for use in IFB and monitoring applications. The Broadcast Host is equipped with XLR input (mic/line), XLR caller output, 3.5 mm line I/O, and a Guest Module remote control jack.



#JKHOST  
**\$439<sup>95</sup>**

**JK AUDIO****Innkeeper PBX****Desktop Digital Hybrid**

The Innkeeper PBX is a digital hybrid telephone interface designed to convert multi-line PBX type telephone systems into an affordable talk show console while maintaining excellent separation between talent and the caller. It is equipped with an XLR input (mic/line), XLR caller output, 3.5 mm line I/O, and a switchable handset input (electret, dynamic, and carbon).



#JKINNPBX  
**\$439<sup>95</sup>**

**JK AUDIO****ComPack****Universal Telephone Audio Interface**

The Compack is a handheld road tool for getting audio in and out of analog phone lines, PBX systems, and cell phones; ideal for remote broadcasts, IFB feeds, phone interviews, or as a telecom interface for beltpack intercom systems. It is equipped with an XLR input (mic/line switch), a 3.5mm line input, and a 1/4" headphone jack.

#JKCOMP  
**\$499<sup>95</sup>**

**JK AUDIO****RemoteMix C+****Portable Remote Mixer**

The RemoteMix C+ is a combination audio mixer, headphone amplifier, and telephone hybrid ideal for remote broadcasts, sporting events, and field reporting. It is equipped with (2) XLR microphone inputs with independent level controls, (2) 1/4" headphone jacks, RCA I/O and a DTMF/Pulse keypad for dialing out. Time Delayed Peak Limiter and VU Meter are included to help to control transmit levels.

#JKRMC  
**\$529<sup>95</sup>**

**JK AUDIO****RemoteMix 3****Portable Remote Mixer**

The RemoteMix 3 is a combination audio mixer, headphone amplifier, telephone hybrid, and PBX telephone interface ideal for remote broadcasts and field reporting. It is equipped with a built-in push-to-talk condenser microphone & monitor speaker, (2) XLR microphone inputs with independent level controls, (2) 1/4" headphone jacks, RCA I/O, transmit VU meter, a 3-position handset type switch and a TMF/Pulse keypad for dialing out.



#JKRM3  
**\$796<sup>50</sup>**

**JK AUDIO****RemoteMix Sport****Portable Remote Mixer**

The RemoteMix Sport is a phone line hybrid mixer and universal handset interface designed for sports broadcast applications with multiple commentators. It is equipped with (3) XLR inputs, (3) 1/4" headphone outputs, built-in push-to-talk condenser microphone & monitor speaker, 1/4" headphone cue input, RCA I/O, transmit VU meter, a 3-position handset type switch, and a TMF/Pulse keypad for dialing out.



#JKRMS  
**\$884<sup>95</sup>**

**PSC****Phone Tap**

Phone Tap is an interface for recording audio from a standard telephone line. It is ideal for radio, television, and film applications. This device is equipped with Ring & Seize indicator LED's, is completely line-powered, and the XLR audio output is transformer isolated from the phone line. This device can be connected to virtually any standard telephone line via the supplied cables and adapters.

#PSPT  
**\$227<sup>05</sup>**

**ROLLS****P19****Phone Patch II**

The P19 is an affordable audio interface that takes a signal from a standard telephone jack and, via transformer isolation, connects to a pair of RCA jacks or a stereo 1/8" jack (isolation keeps the output signal separate from the telephone line). Ideal for broadcast, conference rooms, phone training, or any basic telephone recording application.

#ROPI9  
**\$39<sup>95</sup>**



## JK AUDIO innkeeper 1x

The innkeeper 1X is a desktop audio interface that provides audio input and output for your telephone lines, and is an excellent tool for broadcast, teleconferencing, or auto-answer IFB feeds.

- Excellent separation of caller and talent voice
- Balanced audio connections
- Voice Presence Compensation

**Innkeeper 1rx** rackmount version of above #JKINN1RX....\$778.95

**Guest Module 1** remote control of innkeepers #JKGM1....\$123.50

#JKINN1X  
**\$707<sup>50</sup>**



## JK AUDIO RemoteMix 4

This communications tool features a phone line hybrid with keypad, a PBX handset interface, and a cell phone interface in a tough, portable housing that is smaller than a lunch box. All of these component parts were designed to work harmoniously and save time in the field.

- (4) XLR mic inputs with mic/line pad channels 3 & 4
- Dual compartments for hot swapping batteries
- Features Bluetooth Wireless Technology

#JKRM4  
**\$1395<sup>00</sup>**



## JK AUDIO innkeeper 2



The innkeeper 2 houses two independent digital hybrids in a 1U rack space, allowing you to send audio signals into the phone line while maintaining excellent separation between your voice and the caller.

- An auxiliary telephone jack for each line
- Memory/Speed Dial from phone list
- Auto answer and disconnect

#JKINN2  
**\$1299<sup>95</sup>**

## JK AUDIO innkeeper 4



Innkeeper 4 adds four separate digital hybrids to your broadcast studio, talk show, church PA, or conference room and offers balanced XLR output for each caller's voice.

- 1 kHz 0dB test tone for equipment setup
- 12 key telephone style keypad and alpha-numeric legend
- Auxiliary Handset jack (electret biased)

#JKINN4  
**\$1597<sup>50</sup>**

## JK AUDIO Daptor One

This little box converts your earpiece and microphone signals into a balanced RJ11 phone line that can be plugged directly into any JK Audio RemoteMix series mixer.

- Hybrid circuit minimizes echo
- No battery or AC needed
- Durable die-cast aluminum construction

#JKDAP1  
**\$118<sup>95</sup>**



## JK AUDIO Daptor Two

By plugging the Daptor Two into the 2.5mm headset jack of any wireless cell phone that accepts a third party headset or earpiece, you can send and receive audio from your mixer or tape recorder through the cell phone.

- XLR and 1/4" input and output
- Excellent choice for remote broadcasts
- Cell phone recognizes Daptor Two as a headset

#JKDAP2  
**\$159<sup>95</sup>**



## JK AUDIO Daptor Three



The Daptor Three provides balanced and unbalanced connections for your cell phone using Bluetooth Wireless Technology. This professional interface will also connect to any other product, such as a laptop, that allows a wireless headset connection.

- Balanced XLR input and output
- Stereo mini line input and output
- Weighs just 7 ounces

#JKDAP3  
**\$375<sup>00</sup>**

## JK AUDIO Voice Path



Voice Path routes the audio from any telephone into your PC sound card, allowing you to record, edit, and play your conversation right back into the phone line.

- Straightforward telephone/computer interface
- Single button selects record or play modes
- Works with analog and digital phone systems

#JKVOICE  
**\$108<sup>95</sup>**

**JK AUDIO****QuickTap IFB**

Connecting the QuickTap IFB between your telephone and handset gives you instant access to audio from any telephone system via its XLR output. The 1/8" mini jack allows the connection of an IFB earpiece.



#JKQTIFB  
**\$124<sup>95</sup>**

- Telephone handset IFB tap for interviews and monitoring
- Works with analog, digital, PBX, and ISDN telephones
- (1) XLR and (1) 1/8" mono output jack with attenuator

**SOUND DEVICES****HX-3 Headphone Amplifier**

The portable HX-3 headphone distribution amplifier provides three high-output isolated headphone feeds with individual volume control. Loop output links multiple units, and it is powered by two AA's or external 5-18 VDC.



#SOHX3  
**\$297<sup>00</sup>**

- XLR, 1/4", and 1/8" stereo inputs
- Stereo or mono monitoring
- High strength, extruded aluminum chassis

**JK AUDIO****RemoteAmp**

The RemoteAmp is ideal for use as an IFB earpiece or headphone amplifier, or as an on-stage monitor headphone amplifier. This solidly-built unit clips to your beltback and accepts a 3-pin XLR audio input.

#JKRAMP  
**\$189<sup>95</sup>**

- 1/4" earpiece and 1/8" headphone outputs
- Battery test indicator and on/off switch
- Internal jumper for extra input boost

**SOUND DEVICES****MP-1 Portable Microphone Preamp**

The MP-1 is a portable, battery-powered microphone pre-amplifier with phantom power. Its high-quality construction will provide years of superb audio performance under the most punishing field conditions.

#SOMP1  
**\$299<sup>00</sup>**

- Provides 48V or 12V phantom power
- Eleven-stepped knob provides 66dB of gain
- Limiter makes unit virtually "unclippable"

**PRO CO SOUND****Short Stop**

The Short Stop is a passive momentary microphone-muting switch that allows the performer to cough or clear his/her throat while the momentary foot switch is depressed. An ideal way to prevent embarrassing sounds from reaching the audience.



#PRCDSSM  
**\$82<sup>50</sup>**

- (1) XLR input and (1) XLR output
- Rugged metal construction
- Use dynamic or condenser microphones

**PRO CO SOUND****Panic Button**

The Panic Button was designed for live entertainers on stage to switch their microphone signal from the stage to a personal roadie or monitor mixer with emergency calls for help (broken string, dead battery, spilled drink, etc.).



#PRCDPBZ  
**\$164<sup>95</sup>**

- No "pop" switching between channels
- (1) XLR in and (2) XLR outputs
- Includes AC power supply

**PRO CO SOUND****Approach the Bench**

#PRCDAB  
**\$164<sup>95</sup>**

This latching footswitch allows the judge to turn the podium microphone on or off during attorney discussions at the bench. The indicator light glows green when the mic is on and red when the mic is off.

- XLR in, (1) XLR out and Switch out
- Switch for outboard white noise generator
- Includes AC power supply

**PRO CO SOUND****Approach the Bench w/ White Noise**

#PRCDABWN  
**\$164<sup>95</sup>**

The Approach the Bench mic mute Version B has a white noise generator built into it that sends a line level signal to the existing sound system to provide white noise above the jury box.

- (1) XLR in, (1) XLR out, and Noise out
- Green/Red status indicator light
- Includes AC power supply

**WHIRLWIND**  
**MD-1**

The MD-1 is a portable microphone preamp/line driver and headphone amp designed for location recording. An industry standard for parabolic, boom, and interview mic applications, the MD-1 is the ideal mic preamp for those who demand studio quality in a rugged, battery-operated package.



#WHMD1  
**\$299<sup>95</sup>**

**ROLLS**  
**PM50sOB**

The PM50sOB mixes a microphone signal with a stereo monitor signal to a headphone output. The microphone signal is passed through (hard-wired for no signal degradation) to a mixer or pre-amplifier. The PM50sOB is a perfect device for boompole operators who need to monitor their own signal.



#ROP50SOB  
**\$64<sup>95</sup>**

**SOUND DEVICES**  
**MM-1**



The MM-1 is a single-channel, portable microphone preamplifier with a powerful headphone monitoring function designed for complex broadcast remotes, theatrical productions,

and intercom setups. It is equipped with a studio-quality microphone preamplifier with phantom power (48V, 12V & 12V T-power), a high-pass filter, and a built-in limiter. It is powered by two AA batteries or external 5-18 VDC.

#SOMM1  
**\$349<sup>00</sup>**

**PSC**  
**DV PROMIX 1**



The DV PROMIX 1 is a flexible microphone preamp/monitoring system designed for professional location sound applications. It features (1) XLR Mic input & (1) XLR Monitor input, switchable 12T/48

phantom power, switchable limiters, a low cut filter, LED peak metering and powers via two 9V batteries or external 7-16VDC.

#PSDVPM1  
**\$403<sup>75</sup>**

**BRCFDV1** optional boompole remote #PSBRCFDV1.....**\$68.40**

**PRO-CO**  
**Commentator**

The Commentator is a multi-feed headphone junction box and microphone muting switch with status indicator showing green for "on air" and red for "off air." Output A is the live broadcast feed. Output B allows the broadcaster to talk to his crew/producer live, without the audience overhearing.



#PRCDC  
**\$194<sup>95</sup>**

**PRO-CO**  
**Sign Off**  
**Latching Muting Switch**

The Sign Off is a passive latching microphone muting switch that allows the operator to turn a microphone on or off at a press of a button. It is equipped with an XLR input and output and a selection switch for dynamic or condenser microphones. The Sign Off is an ideal solution for singing drummers.



#PRCDSOPL  
**\$82<sup>50</sup>**

**ROLLS**  
**MM11**

Microphone Muting Switch



The new MM11 MicMute is a simple device designed to temporarily mute a balanced XLR signal. Simply press the switch for muting and release to hear the signal again. There's a large actuator switch that can be operated by hand or used as a foot switch. The unit is housed in a hefty .090 inch steel chassis.

#ROMM11  
**\$44<sup>95</sup>**

**PRO-CO**  
**Power Mute**

Active Muting Switch



The Power Mute is an active muting switch that can be used in momentary-switch mode (press to mute or press to talk) or latching-switch mode (Mic on / Mic off). It is equipped with a status indicator light, an XLR input and output, and includes an AC power supply.

#PRCDPA  
**\$148<sup>50</sup>**



**REMOTE AUDIO**

**HN-7506DBM**

**High Noise Dynamic Boom Headset**

The HN-7506DBM is a high noise headset with a broadcast-quality miniature dynamic boom microphone installed (microphone terminates with 3-pin male XLR). The large, oil-filled cup design reduces pressure and fatigue, and provides superior isolation with more than 40dB of attenuation. It is equipped with 40mm Neodymium drivers (from the popular Sony 7506's) and 1/4" stereo and 1/8" mini connections.

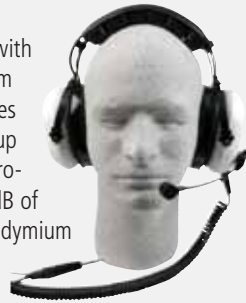

#REHN7506M  
**\$400<sup>00</sup>**

**SHURE**

**SM 2**

**Headset with Dynamic Microphone**

The SM2 is a self-adjusting dual headset with boom-mounted dynamic microphone designed for news and sports broadcasting, special events remote announcing, interviewing, and intercom system applications. Its free-swiveling cushioned earpieces promote user comfort and lower fatigue during extended periods of use. Unidirectional microphone polar pattern (for effective noise reduction). Microphone frequency response: 50 to 15,000Hz



#SHSM2  
**\$236<sup>95</sup>**

**BEYERDYNAMIC**

**DT 290**

**Headset with Dynamic Microphone**



The DT 290 is a dual-sided broadcast headset with a dynamic hyper-cardioid flexible boom microphone, designed for use with Telex and Clear-Com communications systems. Comfortable, ruggedly constructed and capable of wiring for mono or stereo operation, the headphones offer a wide 10Hz-30kHz frequency reproduction and modular construction for quick servicing in the field.

**DT 190** Grey/Black, 250-Ohm, straight-boom version of above #BEDT190 ..... **\$299.00**

#BEDT290\*  
**\$219<sup>00</sup>**

**SENNHEISER**

**HMD-25XQ**

**Headset with Dynamic Microphone**

The HMD25-XQ is a professional dual-sided communications headset equipped with a supercardioid dynamic boom microphone. The adjustable swiveling boom for the microphone can be positioned on left or right side and the cushioned noise-attenuating earcups provide excellent sound isolation. The lightweight design and two-piece padded headband ensures a comfortable fit over extended periods of use. Headphone: 400 ohms; Frequency response: 20Hz-16kHz



#SEHMD25XQ  
**\$419<sup>95</sup>**

**BEYERDYNAMIC**

**DT 280**

**Single-Ear Headset with Dynamic Microphone**

The DT 280 is a lightweight single-sided broadcast headset with a dynamic hyper-cardioid flexible boom microphone, designed for on-air commentary, sports announcing and intercom use. This comfortable reference-quality monophone delivers an amazing 10Hz-30kHz frequency response and reliable microphone noise-canceling properties.



#BEDT280\*  
**\$199<sup>00</sup>**

**BEYERDYNAMIC**

**DT 109**

**Headset with Dynamic Microphone**

The DT 109 is a dual-sided broadcast headset with a dynamic hyper-cardioid boom microphone, comfortably padded and ruggedly constructed. The high-output 50-Ohm headphones offer a crystalline 30Hz-20kHz frequency reproduction and modular construction for quick servicing in the field.

**DT 108** single-sided version of above #BEDT10850\* ..... **\$154.95**



#BEDT10950\*  
**\$249<sup>00</sup>**

**BEYERDYNAMIC**

**Detachable Cables**

**Detachable Cables for DT 280/290 Series Headsets**

- K 190.00** 5 ft., unterminated #BEK19000 ..... **\$29.95**
- K 190.00** 10 ft., unterminated #BEK1900030 ..... **\$39.95**
- K 190.28** 5 ft., 4-pin XLR female for Clear-Com/Telex #BEK19028 ..... **\$47.95**
- K 190.39** 5 ft., 5-pin XLR male for Pro Cameras #BEK19039 ..... **\$49.95**
- K 190.40** 5 ft., 3-pin XLR male, 1/4" jack for General Use #BEK1904015... **\$58.50**
- K 190.40** 10 ft., 3-pin XLR male, 1/4" for General Use #BEK1904030M ... **\$64.95**
- K 190.41** 5 ft., 5-pin XLR male for RTS #BEK1904030M ..... **\$64.95**
- K 190.48** 10 ft., (2) stereo-mini jacks for multi-media #BEK190483 ..... **\$52.95**
- WK 190.00** 10 ft., coiled cable, unterminated #BEK19000 ..... **\$59.95**

**BEYERDYNAMIC**

**Detachable Cables**

**for DT 108/109 Series Headsets**

- K 109.00** 5 ft., unterminated #BEK1090015 ..... **\$29.50**
- K 109.00** 10 ft., unterminated #BEK109003 ..... **\$34.95**
- K 109.28** 5 ft., 4-pin XLR female for Clear-Com/Telex #BEK1092815.. **\$49.95**
- K 109.38** 5 ft., 5-pin XLR male for RTS #BEK1093815 ..... **\$49.95**
- K 109.40** 5 ft., 3-pin XLR male, 1/4" jack for General Use #BEK1094015.. **\$59.95**
- K 109.42** 5 ft., 4-pin XLR male for RTS/Telex #BEK1094215 ..... **\$49.95**
- K 109.48** 10 ft., (2) stereo-mini jacks for multi-media #BEK109483.. **\$39.95**
- WK 109.00** 10 ft., coiled cable, unterminated #BEK10900 ..... **\$39.95**

**COMTEK****BST-25****Base Station Transmitter**

The BST-25 is a base station transmitter designed for high fidelity IFB, cueing, and remote program monitoring (for use with PR-25 TV 5-6 & PR-216/TV 5-6 receivers). Ideal for broadcast, film production, and live entertainment applications, it provides 119 user-selectable channels in the TV-5 & TV-6 spectrum (76.2–87.8 MHz), balanced mic or line level input and a switchable EQ circuit for superb speech intelligibility.

#COBST25  
**\$1199<sup>95</sup>****LECTROSONICS****IFB Kit****IFB System**

The IFB System is used for a wide variety of applications including film and television production, live sound, theater, tour guides, and language interpretation. This complete kit includes: IFB beltpack receiver, LM wireless beltpack transmitter, M152 omnidirectional lavalier microphone, and an Otto Engineering single IFB earphone with 1/8" miniplug (beige).

#LEIFBK121  
**CALL****COMTEK****PR-216 TV 5/6****Personal Receiver**

The PR-216/TV 5-6 is a professional-quality, personal monitor receiver designed to for use with the BST-25 transmitter. It is used in TV production studios and ENG trucks for director IFB, talent cueing, and camera crews. This high-performance, frequency-agile personal receiver operates in the TV-5/6 bands (76.2–87.8 MHz) and has 119 preset channels.

#COPR216TV56  
**\$309<sup>95</sup>****VOICE TECHNOLOGIES****VT600****IFB Earpiece**

The VT600 is an IFB earpiece designed to interface with any wireless or hardwired receiver for discrete monitoring applications. It provides a universal fit with replaceable foam tips, a straight 5-ft cable with clip and a 1/8" (3.5mm) mini connector. Ideal for newscasters, security professionals, and stage performers; Frequency response: 200Hz–8kHz; Impedance: 500 ohms

#VOVT0083  
**\$110<sup>00</sup>****COMTEK****RC-216 Option 1****Wireless Cueing System**

The RC-216 Receive-A-Cue system is a professional-quality, digitally-synthesized wireless cueing system (with microphone muting switch) designed for broadcast and film-cueing applications. It Includes: M-216 wireless microphone transmitter, PR-216 personal receiver, IR-230 inductor receiver, NTC-102 neck-loop transducer, CM-183 lapel mic, SM-N earphone assembly and C-216 carrying case.

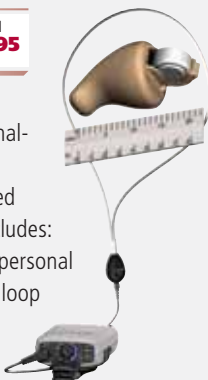
#CORC21601  
**\$1179<sup>95</sup>****OTTO ENGINEERING****Lightweight Earpiece****IFB Earpiece**

The Otto lightweight IFB earpiece is a personal monitoring earphone designed for applications requiring discreet communications such as film and TV production, security and crowd control. It features a 48" straight cable, a low-profile, flexible transparent acoustic tube, and a right-angle 1/8" (3.5mm) mini-plug connector. An attached clip secures the base to a shirt or jacket.

#OTV110437  
**\$44<sup>95</sup>****COMTEK****AP 230****Auto-Prompter Kit**

The AP-230 is designed for discreet cueing applications in conjunction with COMTEK personal receivers, miniature tape recorders, digital recorders, MP3 players, etc.

The complete system includes: IR-230 universal-fit ear canal inductor receiver, NTC-102 neck-loop transducer with two 32" down-lead cords (one 1/8" and one 3/32" plug) and the P-11 storage pouch.

#COAP230  
**\$279<sup>95</sup>****OTTO ENGINEERING****V110611****Wireless Ear Receiver w/Squelch**

The Wireless Ear Receiver fits securely in your ear canal. Used in conjunction with either the Otto Flat Pack Inductor or Neck Loop style Inductor to create the invisible inductive field that transmits the radio's sound to the Wireless Ear Receiver. Squelch version mutes the amplifier when no signal is present (includes neck loop).

#OTV110611K  
**\$259<sup>95</sup>**

**PORTACOM****AnchorMan-40**

The AnchorMan-40 from Portacom is a pro-grade, full-duplexing portable wireless intercom system designed for videography, location sound and large houses of worship in need of an affordable communications solution. The belt packs may be assigned to 4 separate groups, and the robust antenna supports a range of up to 250' in duplex mode. An unlimited number of listen-only users may be added to the system, and no base station is required.

#PAM40  
**\$2561<sup>00</sup>**

- Full-duplexing portable wireless intercom system
- (4) BP-900 belt packs in 944-952MHz range
- Gang charger for simultaneous recharge of all belt packs
- PTT or voice activation
- 250' duplex range, 2500' simplex range
- XLR belt pack jacks for single- or double-sided headsets
- (4) rechargeable "AA" battery operation, batteries and case included

**PORTACOM  
COM-40FCS**

The COM-40FCS is a four-person, two-channel wired intercom system consisting of: (4) H-200 headsets, (4) BP-200 belt packs, and (1) PC-100 power console. Easily expandable with the B3-100 branch box and additional headsets, the COM-40FCS is a versatile, low-cost communication solution ideal for broadcasters, videographers, houses of worship, and educational institutions.

#POCOM40FCS  
**\$1982<sup>00</sup>**

- (4) Dual-earpiece headset with Lo-Z noise-canceling mic
- (4) Lightweight aluminum belt packs with volume control, A/B channel switch, mic on/off, and call button with LED
- Rack-mountable power console with (4) outputs, includes AC adapter
- Includes CC-125F deluxe carrying case with foam inserts
- Requires interconnect cables, standard shielded XLR mic cables

**EARTEC****TD902VS**

The TD902VS is a two-person wireless intercom system designed to allow videographers to monitor incoming camera audio in one earpiece while maintaining continuous wireless voice contact with remote crew members. Consisting of two TD 900 full-duplexing radios, a Cyber single-sided headset, and a Monarch dual-sided headset, the TD902VS is an ideal lightweight solution for hands-free communication in the field.

#EATD902VS  
**\$349<sup>95</sup>**

- 1/4-mile operating range
- Standby and Continuous Talk switching
- Independent volume control knob for each user
- Battery Life: 12 hours standby and 5 hours communication
- 4.8V NiCad rechargeable battery and chargers (included)
- Includes plastic hardshell carrying case

**PORTACOM  
H-200**

The H-200 is a dual-earpiece headset with a noise-canceling microphone designed for use with the COM series wired intercom systems.

- Dual-sided, medium weight headset design with dynamic mic
- Standard 4-pin XLR connector, coiled cable
- Padded, adjustable headband

#POH200  
**\$193<sup>00</sup>**

**EARTEC  
SL**

The Slimline is a single-sided, medium-weight headset designed for the Eartec wireless communication systems.

- Single-sided headset design with fully adjustable gooseneck mic boom
- Low-profile, comfortable fit
- Noise-cancelling electret condenser microphone
- 1/8" mini connector

#EASL  
**\$74<sup>95</sup>**

**PORTACOM****H-200S**

The H-200S is a single-earpiece headset with a noise-canceling microphone designed for use with the COM series wired intercom systems.

- Single-sided, medium weight headset design with dynamic mic
- Standard 4-pin XLR connector, coiled cable
- Padded, adjustable headband

#POH200S  
**\$193<sup>00</sup>**

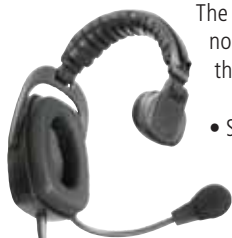
**EARTEC  
SLD**

The SlimLineD is a dual-sided medium-weight headset designed for the Eartec wireless communication systems.

- Dual-sided headset design with fully adjustable gooseneck mic boom
- Low-profile, comfortable fit
- Noise-cancelling electret condenser microphone
- 1/8" mini connector

#EASLD  
**\$94<sup>95</sup>**





**AVIOM**  
**AN-16/i**  
Input Module

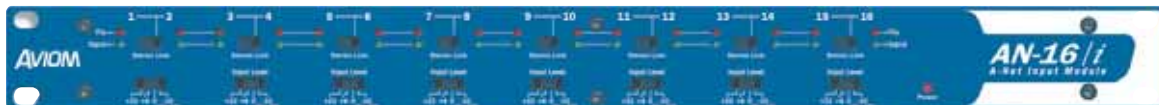

The AN-16/i Input Module allows microphone/line level signals to be used with AN-Series Distributed Audio Network products to create digital snakes and to provide the input stage for the Personal Monitor Mixing Systems. The AN-16/i-M is designed to complement the existing products in the Distributed Audio Network line, such as the AN-16/i Input Module and AN-16/o Output Module.

#AVAN16I  
**\$1070<sup>00</sup>**

- (16) high-quality mic pre-amplifiers, with 24-bit A/D converters
- XLR mic or 1/4" TRS balanced inputs on combo jacks
- 48V phantom power on each channel, with LED
- Three-segment level LED indicators
- Continuously variable gain knob
- Phase switch per channel



**AVIOM**  
**A-16II**

The A-16II is the Personal Monitor Mixer component of Aviom's Personal Monitor Mixing System. Designed for stage and studio use, the A-16II gives each performer control over channel volume, grouping, pan, stereo spread, and master volume. Each A-16II Personal Mixer in the system can create a unique monitor mix for a performer, and the stereo output can be used to drive floor wedge monitors or headphones.

#AVA16II  
**\$575<sup>00</sup>**

- 16-channel select buttons with dual LED's
- True stereo mixing with fully adjustable pan
- Dedicated Recall, Group, Solo, and Mute buttons
- 16 user Preset memory locations
- New Held Solo mode
- Create three Groups per mix preset

**AVIOM**  
**A-16D Pro**  
A-Net Distributor

The A-16D is designed to distribute the A-Net signal from any A-Net-compatible device, including another A-16D Distributor. Each A-16D accepts one A-Net input signal and provides for eight simultaneous A-Net outputs using Category 5 Cables. The A-16D Distributor eliminates the need to daisy chain A-Net devices, simplifying stage and studio setups.

- One A-Net input, and eight A-Net outputs
- Distribute A-Net from a central location or from other A-16D Distributors
- Supports cable lengths of up to 500'
- A-Net activity LEDs on the main input
- Multiple A-16D Distributors can be used in a system

#AVA16DPRO  
**\$1190<sup>00</sup>**



**A-16D** 1/2 Rack 1 x 8 A-Net distributor #AVA16D. **\$420.00**



**TELEX**  
**BTR-300 & TR-300**

The BTR-300/TR-300 system is a cost-effective, full-duplex professional intercom system ideal for the broadcast and videographers' market. Up to four base stations and sixteen individual beltpacks can be used simultaneously.

#TEBTR300812A  
**\$2592<sup>00</sup>**

#TETR300812A1  
**\$760<sup>50</sup>**

The **BTR-300** is a VHF wireless intercom base station that supports up to four, full-duplex Telex TR-300 beltpack transmitters, operates at ranges up to 2000 feet line of sight, and operates in the high VHF frequency range.

The **TR-300** is a single-channel VHF wireless intercom beltpack for use with the BTR-300 base station capable of over 24 hours of battery life using standard AA batteries, and 18 hours using NIMH rechargeable batteries.

**TELEX**  
**HR-1**

#TEHR1  
**\$201<sup>60</sup>**

The HR-1 is a single-sided, medium-weight, passive noise-reduction headset designed for use with Telex wireless intercom systems.

- Single-sided headset design with noise-cancelling boom microphone
- Ergonomic headband design assures hours of comfortable wear
- Folding design for easy storage
- Connectors: 4-pin XLR male/female or 5-pin XLR male/female



**TELEX**  
**HR-2**

#TEHR2  
**\$219<sup>60</sup>**

The HR-2 is a dual-sided, medium-weight, passive noise-reduction headset with a comfortable foam-filled headband pad and ear cushions.

- Dual-sided headset design with noise-cancelling boom microphone
- Noise-reduction rating of 21dB
- Folding design for easy storage
- Connectors: 4-pin XLR male/female or 5-pin XLR male/female



**WHIRLWIND****Medusa****Standard Series**

The Medusa Standard Series features a heavy-duty, powder-coated steel stage box with durably constructed connectors, a wire mesh fan-out support, and shielded, flexible multi-pair cabling. The connectors are engraved with numbers and letters for easy identification.



**MS164XL100** (16) XLR inputs  
(4) XLR returns (100 ft.)  
#WHMS164XL100..... **\$453.50**

**MS244XL150** (24) XLR inputs  
(4) XLR returns (150 ft.)  
#WHMS244XL150 ..... **\$808.95**

**WHIRLWIND****Connect Series**

With hand-soldered connections, wire mesh strain relief, and multi-layer heat shrink, the Connect Series snakes feature many of the same high-quality components as the Medusa Series, providing an ideal economical solution for fixed installation or live performance applications.



**SNK164X100** (16) XLR inputs  
(4) returns (100 ft.)  
#WHSNK164X100..... **\$363.95**

**SNK244X100** (24) XLR inputs  
(4) returns (100 ft.)  
#WHSNK244X100 ..... **\$479.95**

**WHIRLWIND****Medusa Power Series**

The Medusa Power Series snakes are specifically designed for use with self-powered mixing boards. Engineered with a heavy-duty steel stage box loaded with female XLR inputs, 1/4" TRS returns, and four 1/4" speaker jacks.

**MP12150** (12) XLR inputs  
(4) 1/4" TRS returns (150 ft.)  
#WHMP12150 ..... **\$787.95**

**MP16100** (16) XLR inputs  
no returns (100 ft.)  
#WHMP16100 ..... **\$618.50**

**WHIRLWIND****Cable Reels**

Designed for applications with a fanout at the reel end, the WD5 incorporates a split reel for the fanout section and pigbag. It features a durable base tray for storage of a stage box, an ergonomic carrying handle, and an adjustable friction brake to prevent cable overrun.

**WD6** compact stackable reel with built-in customizable connector panel #WHWD6.. **\$467.50**  
**WD7C** larger version with available casters  
#WHWD7C ..... **\$538.95**

#WHWD5  
**\$429<sup>95</sup>**

**WHIRLWIND****Medusa MultiSnake 10**

The Medusa MultiSnake 10 combines 4 mic lines with 6 dual-purpose mic/DI lines in one small drop snake, with Neutrik combo connectors wired to 6 mic channel lines and 1/4" sections, wired to 6 internal DI's featuring individual ground lift switches.

- (4) XLR and (6) combo jack inputs
- 50 ft.



#WHMLS10X650  
**\$647<sup>95</sup>**

**WHIRLWIND****Medusa MultiSnake**

Ideal for small keyboard rigs, DJ mixing, and small ensembles, the MultiSnake combines four premium direct boxes with a 4-channel 50-foot mic snake. Custom lengths and options such as multi-pin disconnects are available.

- (4) XLR and (4) 1/4" TS DI inputs
- 50 ft.



#WHMLTSN4X450  
**\$447<sup>95</sup>**

**WHIRLWIND****MINI-12 Drop Snake**

The MINI-12 Drop Snake is ideal for cleaning up cable runs in the studio or on stage. It features clearly labeled side-exit connectors and fits into places where traditional boxes would be too bulky.

- (12) XLR inputs
- 50 ft.

#WHMS12MNR50  
**\$277<sup>50</sup>**

**WHIRLWIND****MINI-6**

A 6-channel version of the MINI-12, the MINI-6 features clearly labeled side-exit connectors and fits in most places deemed too small for traditional boxes. Great for cleaning up cable runs in the studio and on stage.

- (6) XLR inputs • 50 ft.

#WHMS6MNR50  
**\$179<sup>95</sup>**

**PRO-CO SOUND**

**StageMaster (fan to box)**

The durable StageMaster Series fan-to-box P.A. snakes are designed for professional fixed installations and stage use. The flexible main cable is easily coiled, and the stagebox, built from a 16-gauge connector plate, features a blank template overlay for noting all channel ID numbers. Multi-pair cabling is standard, and PVC tubing protects the fan out-channels.



**SMA2408FBQ150** (24) XLR inputs (8) 1/4" TRS returns (150 ft.) #PRSF24X8P15.....**\$1029.95**

**SMA2408FBQ100** (24) XLR inputs (8) 1/4" TRS returns (100 ft.) #PRSF24X8P10.....**\$762.50**

**HORIZON MUSIC**

**Stage Series**

Built for touring or permanent installs, the Stage Series snakes feature a durable stage box-to-fan design with a reinforced box-to-fan connection and steel mesh fanout strain relief.



**SFB24M4P10**

(24) XLR inputs (4) 1/4" TRS returns (100 ft.)

#HOSFB24M4P10.....**\$408.95**

**WHIRLWIND**

**Medusa Multi-track 16-Channel Snake**

The Medusa Multi-Track 16-Channel Snake is configured with 16 XLR male and 16 XLR female connectors on multi-pair cables with insulated conductors, and a heat-shrink fan-out at each end. All channels are conveniently numbered for easy identification.



**MT-16-FM-10** (8) XLR-M (8) XLR-F connectors (10 ft.) #WHMT16FM10...**\$176.95**

**MT-16-FM-25** (8) XLR-M (8) XLR-F connectors (25 ft.) #WHMT16FM25...**\$209.95**

**MT-16-FM-50** (8) XLR-M (8) XLR-F connectors (50 ft.) #WHMT16FM50...**\$269.95**

**HOSA**

**SNU Series**

Available in 8-, 12-, 16-, and 24-channel versions, the SNU series box-to-fan snakes are cost-effective solutions for live/PA and recording studios. All locking connections are made via reliable Neutrik brand connectors.



**FB8X4P50** (8) XLR inputs (4)

1/4" TRS returns (50 ft.)

#HOSFB8X4P50.....**\$247.95**

**FB16X4P100** (16) XLR inputs

(4) 1/4" TRS returns (100 ft.)

#HOSFB16X4P100.....**\$511.95**

**HORIZON MUSIC**

**Stage Series**

Featuring rugged steel connector jackets and high-quality shielding, the Horizon fan-to-fan multi-pair audio snakes are ideally suited for interfacing multi-track recorders or outboard equipment to live and studio mixing consoles.



**S8XFXM50** (8) XLR-F (8)

XLR-M connectors (50 ft.)

#HOS8XFXM50.....**\$139.95**

**S8SPMXM30** (8) TRS phone

(8) XLR-M connectors (30 ft.)

#HOS8SPMXM30.....**\$89.95**

**HORIZON MUSIC**

**Professional Snake Reel**

This professional Reel Snake features 16-gauge steel construction and CL-2-rated multi-pair cable. Rubber wheels with locks make for easy portability; ideal for live sound applications.



#HOSR24X4X100  
**\$549<sup>95</sup>**

- Snake Reel (24) inputs (4) XLR returns
- 100 ft.
- Choice of XLR or 1/4" TRS locking returns

**HOSA**

**XLR-800 Series**



Ideal for recording studios, these highly affordable 8-channel XLR (M)-XLR (F) snakes come in three different sizes and feature durable steel connectors.

**8XM8XF9** 9.9 ft. #HO8XM8XF9.....**\$69.95**

**8XM8XF16** 16.5 ft. #HO8XM8XF16.....**\$77.50**

**8XM8XF23** 23.1 ft. #HO8XM8XF23.....**\$79.95**

**HOSA**

**CPR-800 Series**

Ideal for patching multiple line level instruments and recording devices in the studio, including keyboards, sound modules, CD burners, mixers and more. Molded terminations.



**8PM8R6** (8) RCA - (8) 1/4" TS (6.6 ft.)

#HO8PM8RM6.....**\$21.95**

**8PM8R9** (8) RCA - (8) 1/4" TS connectors

(9.9 ft.) #HO8PM8RM9.....**\$24.95**

**8PM8R23** (8) RCA - (8) 1/4" TS

connectors (32.1 ft.)

#HO8PM8RM23.....**\$42.95**



**SINGLE AUDIO INTERCONNECTS**

**Unbalanced 1/4" Phone to 1/4" Phone**

HOPMPM1	1 ft.	<b>2.95</b>	
HOPMPM5	5 ft.	<b>3.95</b>	
HOPMPM10	10 ft.	<b>4.95</b>	
HOPMPM15	15 ft.	<b>6.50</b>	

**RCA to RCA**

	HORR3	3 ft.	<b>2.95</b>
	HORR10	10 ft.	<b>4.50</b>
	HORR20	20 ft.	<b>6.50</b>

**RCA to 1/4" Phone**

HOPMRM3	3 ft.	<b>2.95</b>	
HOPMR10	10 ft.	<b>4.50</b>	
HOPMR15	15 ft.	<b>5.95</b>	

**Balanced 1/4" TRS Phone to 1/4" TRS Phone**

	HOSPMSPM3	3 ft.	<b>4.95</b>
	HOSPMSPM10	10 ft.	<b>6.50</b>
	HOSPMSPM25	25 ft.	<b>9.50</b>

**8-CHANNEL SNAKES**

**RCA to 1/4" Phone**

HOSTX802M	6.6 ft.	<b>39.95</b>	
HO8SPM8XM13	13.2 ft.	<b>64.50</b>	
HO8SPM8XM23	23.1 ft.	<b>79.95</b>	
HOSTX802F	6.6 ft.	<b>39.95</b>	
HO8SPM8XF13	13.2 ft.	<b>67.95</b>	
HO8SPM8XF23	23.1 ft.	<b>84.95</b>	

**RCA to RCA**

	HO8R8R6	6.6 ft.	<b>19.95</b>
	HO8R8R9	9.9 ft.	<b>23.95</b>
	HO8R8R13	13.2 ft.	<b>28.95</b>
	HO8R8R16	16.5 ft.	<b>34.95</b>
	HO8R8R23	23.1 ft.	<b>46.50</b>

**Balanced 1/4" TRS Phone to XLR**

HOSTX802M	6.6 ft.	<b>39.95</b>	
HO8SPM8XM13	13.2 ft.	<b>64.50</b>	
HO8SPM8XM23	23.1 ft.	<b>79.95</b>	
HOSTX802F	6.6 ft.	<b>39.95</b>	
HO8SPM8XF13	13.2 ft.	<b>67.95</b>	
HO8SPM8XF23	23.1 ft.	<b>84.95</b>	

**Unbalanced 1/4" TRS Phone to XLR**

	HOPXM803	male	9.9 ft.	<b>34.95</b>
	HO8PM8XM16	male	16.5 ft.	<b>54.95</b>
	HOPXF803	female	9.9 ft.	<b>63.95</b>
	HO8PM8XF16	female	16.5 ft.	<b>57.50</b>

**Unbalanced RCA to XLR**

HOXRM803MTL	male	9.9 ft.	<b>56.50</b>	
HOXRM805MTL	male	16.5 ft.	<b>66.50</b>	
HOXRF803MTL	female	9.9 ft.	<b>66.50</b>	
HOXRF805MTL	female	16.5 ft.	<b>76.95</b>	

**Balanced TRS 1/4" Phone to TRS 1/4" Phone**

	HOCSS801	3.3 ft.	<b>33.95</b>
	HO8SPM8SPM13	13.2 ft.	<b>49.95</b>
	HO8SPM8SPM23	23.1 ft.	<b>67.50</b>

**Unbalanced 1/4" Phone to 1/4" Phone**

HO8PM8PM3	3.3 ft.	<b>17.95</b>	
HO8PM8PM9	9.9 ft.	<b>29.95</b>	
HO8PM8PM16	16.5 ft.	<b>33.95</b>	
HO8PM8PM23	23.1 ft.	<b>39.95</b>	

**SINGLE AUDIO INTERCONNECTS**

**RCA to RCA**

	HOCRA201	Nickel Plated	1 m	<b>6.50</b>
	HOCRA203	Nickel Plated	3 m	<b>8.95</b>
	HOCRA206	Nickel Plated	5 m	<b>14.50</b>
	HO2R2R3	Gold Plated	3.3 ft.	<b>5.50</b>
	HO2R2R6	Gold Plated	6.6 ft.	<b>5.95</b>
	HO2R2R9	Gold Plated	9.9 ft.	<b>6.50</b>
	HO2R2R13	Gold Plated	13.2 ft.	<b>7.50</b>
	HOCRA403	Nickel Plated	3 ft.	<b>8.95</b>
	HOCRA410	Nickel Plated	10 ft.	<b>11.95</b>
	HOCRA420	Nickel Plated	20 ft.	<b>17.50</b>
	HOCRA403G	Gold Plated	3 ft.	<b>9.50</b>
	HOCRA405G	Gold Plated	5 ft.	<b>9.95</b>
	HOCRA410G	Gold Plated	10 ft.	<b>12.50</b>
	HOCRA415G	Gold Plated	15 ft.	<b>14.50</b>
	HOCRA420G	Gold Plated	20 ft.	<b>16.95</b>

**1/4" Phone to RCA**

	HO2PM2RM3	3.3 ft.	<b>4.95</b>
	HO2PM2RM6	6.6 ft.	<b>5.95</b>
	HO2PM2RM9	9.9 ft.	<b>7.50</b>
	HO2PM2RM13	13.2 ft.	<b>8.95</b>
	HO2PM2RM20	20 ft.	<b>14.95</b>

**1/4" Phone to 1/4" Phone**

	HO2PM2PM3	3.3 ft.	<b>5.95</b>
	HO2PM2PM9	9.9 ft.	<b>7.95</b>
	HO2PM2PM13	13.2 ft.	<b>7.50</b>
	HO2PM2PM20	20 ft.	<b>9.95</b>

**Balanced TRS 1/4" Phone to TRS 1/4" Phone**

	HO2SPM2SPM3	—	3.3 ft.	<b>9.50</b>
	HO2SPM2SPM9	—	9.9 ft.	<b>11.95</b>
	HO2SPM2SPM13	—	13.2 ft.	<b>12.95</b>
	HOCSS403	Nickel Plated	3 ft.	<b>9.50</b>
	HOCSS410	Nickel Plated	10 ft.	<b>12.95</b>
	HOCSS420	Nickel Plated	20 ft.	<b>17.95</b>
	HOCSS403G	Gold Plated	3 ft.	<b>14.50</b>
	HOCSS410G	Gold Plated	10 ft.	<b>16.50</b>
	HOCSS420G	Gold Plated	20 ft.	<b>19.95</b>

**DIGITAL CABLES**

**Coaxial S/PDIF**

	HOS3	3.3 ft.	<b>9.95</b>
	HOS6	6.6 ft.	<b>12.50</b>
	HOS9	9.9 ft.	<b>14.50</b>
	HOS13	13.2 ft.	<b>15.95</b>

**Fiber Optic**

	HOO2	2 ft.	<b>8.95</b>
	HOO3	3 ft.	<b>9.95</b>
	HOO6	6.6 ft.	<b>12.95</b>
	HOO9	9.9 ft.	<b>18.95</b>
	HOO13	13.2 ft.	<b>21.95</b>
	HOO16	16.5 ft.	<b>24.95</b>

**SPEAKER CABLES**

**2-Conductor Speakon to Speakon**

	HOSKT203	3 ft.	<b>19.95</b>
	HOSKT205	5 ft.	<b>19.95</b>
	HOSKT210	10 ft.	<b>25.95</b>
	HOSKT215	15 ft.	<b>29.50</b>
	HOSKT225	25 ft.	<b>39.50</b>
	HOSKT250	50 ft.	<b>64.95</b>

**Speakon to Banana**

	HOSKT203BN	3 ft.	<b>14.95</b>
	HOSKT205BN	5 ft.	<b>17.50</b>
	HOSKT210BN	10 ft.	<b>22.95</b>
	HOSKT215BN	15 ft.	<b>28.95</b>
	HOSKT225BN	25 ft.	<b>36.50</b>
	HOSKT250BN	50 ft.	<b>61.95</b>
	HOSKT2100BN	100 ft.	<b>113.95</b>

**Speakon to 1/4" Phone**

	HOSKT203Q	3 ft.	<b>14.95</b>
	HOSKT205Q	5 ft.	<b>17.50</b>
	HOSKT210Q	10 ft.	<b>22.95</b>
	HOSKT215Q	15 ft.	<b>27.95</b>
	HOSKT225Q	25 ft.	<b>33.50</b>
	HOSKT250Q	50 ft.	<b>54.50</b>
	HOSKT2100Q	100 ft.	<b>93.95</b>

**MIDI CABLES**

**Single Connect**

	HOMM3	3 ft.	<b>4.50</b>
	HOMM5	5 ft.	<b>4.95</b>
	HOMM10	10 ft.	<b>5.95</b>
	HOMM20	20 ft.	<b>8.95</b>

**Single Connect Right Angle**

	HOMMRA3	3 ft.	<b>5.50</b>
	HOMMRA5	5 ft.	<b>6.50</b>
	HOMMRA10	10 ft.	<b>6.50</b>
	HOMMRA15	15 ft.	<b>8.95</b>

**Dual Connect**

	HO2M2M3	3.3 ft.	<b>8.95</b>
	HO2M2M6	6.6 ft.	<b>9.95</b>
	HO2M2M9	9.9 ft.	<b>11.95</b>
	HO2M2M13	13.2 ft.	<b>12.95</b>

**BNC CABLES**

**For use in Data or Wireless Antenna Applications**

	HOBNCS8101	1 ft.	<b>4.95</b>
	HOBNCS8106	6 ft.	<b>6.95</b>
	HOBNCS8115	15 ft.	<b>9.95</b>

**INTERCONNECT**

**XLR to XLR Cables 100 Series**

MOS100M5	5 ft.	<b>19.95</b>	
MOS100M10	10 ft.	<b>21.95</b>	
MOS100M15	15 ft.	<b>24.95</b>	
MOS100M20	20 ft.	<b>29.95</b>	
MOS100M30	30 ft.	<b>39.95</b>	
MOS100M50	50 ft.	<b>59.95</b>	

**500 Series**

MOP500M5	5 ft.	<b>29.95</b>	
MOP500M10	10 ft.	<b>39.95</b>	
MOP500M20	20 ft.	<b>59.95</b>	
MOP500M30	30 ft.	<b>79.95</b>	
MOP500M50	50 ft.	<b>119.95</b>	
MOP500M100	100 ft.	<b>219.95</b>	
MOP500M250	250 ft.	<b>500.00</b>	

**1000 Series**

MOSP1000M5	5 ft.	<b>49.95</b>	
MOSP1000M10	10 ft.	<b>79.95</b>	
MOSP1000M20	20 ft.	<b>129.95</b>	
MOSP1000M30	30 ft.	<b>199.95</b>	

**XLR to XLR Cables Studioliink Balanced Interconnect**

MOMSLX.5	.5 m	<b>24.95</b>	
MOMSLX1	1 m	<b>24.95</b>	
MOMSLX2	2 m	<b>29.95</b>	
MOMSLX3	3 m	<b>34.95</b>	
MOMSLX4	4 m	<b>39.95</b>	
MOMSLX6	6 m	<b>49.95</b>	

**XLR/M to TRS**

MOMSLCMX.5	.5 m	<b>24.95</b>	
MOMSLCMX1	1 m	<b>24.95</b>	
MOMSLCMX3	3 m	<b>34.95</b>	
MOMSLCMX4	4 m	<b>39.95</b>	
MOMSLCMX6	6 m	<b>49.95</b>	

**XLR/F to TRS**

MOMSLCFX.5	.5 m	<b>24.95</b>	
MOMSLCFX1	1 m	<b>24.95</b>	
MOMSLCFX3	3 m	<b>34.95</b>	
MOMSLCFX4	4 m	<b>39.95</b>	
MOMSLCFX6	6 m	<b>49.95</b>	

**TRS to TRS**

MOMSLST.5	.5 m	<b>24.95</b>	
MOMSLST1	1 m	<b>24.95</b>	
MOMSLST2	2 m	<b>29.95</b>	
MOMSLST3	3 m	<b>34.95</b>	
MOMSLST6	6 m	<b>49.95</b>	

**RCA to RCA**

MOMSLR.5	.5 m	<b>19.95</b>	
MOMSLR1	1 m	<b>19.95</b>	
MOMSLR3	3 m	<b>29.95</b>	
MOMSLR6	6 m	<b>44.95</b>	

**RCA to TS Phone**

MOMSLCR1	1 m	<b>19.95</b>	
MOMSLCR2	2 m	<b>24.95</b>	
MOMSLCR3	3 m	<b>29.95</b>	
MOMSLCR4	4 m	<b>34.95</b>	
MOMSLCR6	6 m	<b>44.95</b>	

**TS to TS**

MOMSLM.5	.5 m	<b>19.95</b>	
MOMSLM1	1 m	<b>19.95</b>	
MOMSLM2	2 m	<b>24.95</b>	
MOMSLM3	3 m	<b>29.95</b>	

**DIGITAL**

**100 Series**

MOMDGAESEBU2	2m	<b>64.95</b>	
--------------	----	--------------	--

**S/PDIF Datalink 100 Series**

MOIDL100.5M	.5 m	<b>29.95</b>	
MOIDL1001M	1 m	<b>39.95</b>	
MOIDL1002M	2 m	<b>47.95</b>	
MOIDL1004M	4 m	<b>59.95</b>	

**1000 Series**

MOM1000D1M	1 m	<b>55.00</b>	
MOM1000D2M	2 m	<b>80.00</b>	
MOM1000D4M	4 m	<b>90.00</b>	

**TOSLINK**

MOILS100TM1M	1 m	<b>39.95</b>	
MOILS100TM2M	2 m	<b>44.95</b>	

**INSTRUMENT**

**100 Series**

MOS100L.75	8 in	<b>12.95</b>	
MOS100I1.5	1.5 ft.	<b>12.95</b>	
MOS100I3	3 ft.	<b>14.95</b>	
MOS100I6	6 ft.	<b>16.95</b>	
MOS100I12	12 ft.	<b>19.95</b>	
MOS100I12A	12 ft. angled	<b>19.95</b>	
MOS100I21	21 ft.	<b>24.95</b>	
MOS100I21A	21 ft. angled	<b>24.95</b>	

**500 Series Keyboard**

MOMKEYB6	6 ft.	<b>34.95</b>	
MOMKEYB12	12 ft.	<b>39.95</b>	
MOMKEYB12A	12 ft. angled	<b>39.95</b>	
MOMKEYB21	21 ft.	<b>49.95</b>	
MOMKEYB21A	21 ft. angled	<b>49.95</b>	

**1000 Series**

MOSP1000I.75	8 in	<b>39.95</b>	
MOSP1000I1.5	1.5 ft.	<b>39.95</b>	
MOSP1000I3	3 ft.	<b>49.95</b>	
MOSP1000I6	6 ft.	<b>69.95</b>	
MOSP1000I12	12 ft.	<b>99.95</b>	
MOSP1000I12A	12 ft. angled	<b>99.95</b>	
MOSP1000I21	21 ft.	<b>149.95</b>	
MOSP1000I21A	21 ft. angled	<b>149.95</b>	

**Jazz Series**

MOMJAZZ12A	12 ft. angled to straight	<b>44.95</b>	
MOMJAZZ21A	21 ft. angled to straight	<b>59.95</b>	
MOMJAZZ6	6 ft. straight	<b>39.95</b>	
MOMJAZZ12	12 ft. straight	<b>44.95</b>	

**Rock Series**

MOMROCK12A	12 ft. angled to straight	<b>39.95</b>	
MOMROCK21A	21 ft. angled to straight	<b>49.95</b>	
MOMROCK6	6 ft. straight	<b>34.95</b>	
MOMROCK12	12 ft. straight	<b>39.95</b>	

**Bass Series**

MOMBASS12A	12 ft. angled to straight	<b>39.95</b>	
MOMBASS21A	21 ft. angled to straight	<b>49.95</b>	
MOMBASS6	6 ft. straight	<b>34.95</b>	
MOMBASS12	12 ft. straight	<b>39.95</b>	

**SPEAKER CABLE**

**TS to TS 100 Series**

MOS100S3	3 ft.	<b>12.95</b>	
MOS100S10	10 ft.	<b>19.95</b>	
MOS100S20	20 ft.	<b>29.95</b>	
MOS100S40	40 ft.	<b>44.95</b>	
MOS100S50	50 ft.	<b>54.95</b>	

**500 Series**

MOP500S3	3 ft.	<b>24.95</b>	
MOP500S6MSP	6 ft.	<b>34.95</b>	
MOP500S10	10 ft.	<b>29.95</b>	
MOP500S20	20 ft.	<b>44.95</b>	
MOP500S40	40 ft.	<b>64.95</b>	
MOP500S50	50 ft.	<b>74.95</b>	

**1000 Series**

MOSP1000S3	3 ft.	<b>34.95</b>	
MOSP1000S6	6 ft.	<b>39.95</b>	
MOSP1000S10	10 ft.	<b>44.95</b>	
MOSP1000S20	20 ft.	<b>64.95</b>	
MOSP1000S50	50 ft.	<b>129.95</b>	

**TS to Dual Banana 100 Series**

MOS100S10MT	10 ft.	<b>19.95</b>	
MOS100S20MT	20 ft.	<b>29.95</b>	
MOS100S50MT	50 ft.	<b>54.95</b>	

**500 Series**

MOP500S10MT	10 ft.	<b>34.95</b>	
MOP500S20MT	20 ft.	<b>44.95</b>	
MOP500S50MT	50 ft.	<b>74.95</b>	

**1000 Series**

MOSP1000S10M	10 ft.	<b>44.95</b>	
MOSP1000S20M	20 ft.	<b>64.95</b>	
MOSP1000S50M	50 ft.	<b>129.95</b>	

**Dual Banana to Dual Banana**

MOS100S10DMT	10 ft.	<b>19.95</b>	
MOP500S10DMT	10 ft.	<b>34.95</b>	
MOSP1000S10D	10 ft.	<b>44.95</b>	

**100 Series Speakon to Speakon**

MOS100S10SP	10 ft.	<b>29.95</b>	
MOS100S25SP	25 ft.	<b>39.95</b>	
MOS100S50SP	50 ft.	<b>59.95</b>	

**Speakon to Dual Banana**

MOS100S10SPM	10 ft.	<b>29.95</b>	
MOS100S25SPM	25 ft.	<b>39.95</b>	
MOS100S50SPM	50 ft.	<b>59.95</b>	

**Speakon-Phone TS**

MOS100S10MSP	10 ft.	<b>29.95</b>	
MOS100S25MSP	25 ft.	<b>39.95</b>	
MOS100S50MSP	50 ft.	<b>59.95</b>	

**MIDI CABLE**

**Single Connect**

MOMMIDI3	3 ft.	<b>14.95</b>	
MOMMIDI6	6 ft.	<b>19.95</b>	
MOMMIDI12	12 ft.	<b>24.95</b>	
MOMMIDI25	25 ft.	<b>34.95</b>	

**SINGLE AUDIO INTERCONNECTS**

**Excellines  
RCA to 1/4" Phone**

PRPMR3	3 ft.	<b>24.95</b>	
PRPMR5	5 ft.	<b>24.95</b>	
PRPMR10	10 ft.	<b>27.95</b>	
PRPMR20	20 ft.	<b>32.95</b>	

**Excellines  
Unbalanced 1/4" Phone to 1/4" Phone**

PREIPMPM1	1 ft.	<b>18.95</b>	
PREIPMPM3	3 ft.	<b>18.95</b>	
PREIPMPM5	5 ft.	<b>18.95</b>	
PREIPMPM10Q	10 ft.	<b>38.95</b>	
PREIPMPM15Q	15 ft.	<b>39.95</b>	
PREIPMPM25Q	25 ft.	<b>47.50</b>	
PREIPMPM30Q	30 ft.	<b>49.95</b>	

**Excellines  
Balanced 1/4" Phone to XLR**

PRSPMXM3	3 ft.	<b>34.95</b>	
PRSPMXM10	10 ft.	<b>32.95</b>	
PRSPMXM20	20 ft.	<b>43.95</b>	
PRSMXPF3	3 ft.	<b>34.95</b>	
PRSMXPF10	10 ft.	<b>36.95</b>	
PRSMXPF20	20 ft.	<b>44.95</b>	

**Excellines  
RCA to RCA**

PRRR3	3 ft.	<b>6.95</b>	
PRRR5	5 ft.	<b>18.95</b>	
PRRR10	10 ft.	<b>18.95</b>	
PRRR20	20 ft.	<b>24.95</b>	
PR2R2R3	3 ft.	<b>31.95</b>	
PR2R2R10	10 ft.	<b>36.95</b>	
PR2R2R20	20 ft.	<b>46.95</b>	

**Excellines  
XLR to XLR**

PRXMXFE3	3ft.	<b>28.95</b>	
PREXMXF510	10ft.	<b>31.95</b>	
PREXMXF515	15ft.	<b>34.95</b>	
PRXMXFE20	20ft.	<b>36.95</b>	
PRXMXFE25	25ft.	<b>39.95</b>	
PRXMXFE30	30ft.	<b>43.95</b>	
PRXMXFE50	50ft.	<b>36.50</b>	
PRXMXFE100	100ft.	<b>56.95</b>	

**Sonimaxer  
XLR to XLR**

PRXMXFS10	3 ft.	<b>13.95</b>	
PRXMXFS15	15 ft.	<b>16.95</b>	
PRXMXFS20	20 ft.	<b>18.95</b>	
PRXMXFS25	25 ft.	<b>22.95</b>	
PRXMXFS30	30 ft.	<b>24.95</b>	
PRXMXFS50	50 ft.	<b>33.95</b>	

**MIDI CABLES**

**Excellines**

PRMM3	3 ft.	<b>19.95</b>	
PRMM10	10 ft.	<b>23.95</b>	
PRMM15	15 ft.	<b>25.95</b>	
PRMM20	20 ft.	<b>28.95</b>	
PRMM25	25 ft.	<b>29.95</b>	
PRMM50	50 ft.	<b>43.95</b>	

**SPEAKER CABLES**

**Excellines  
Phone to Speakon**

PR2PMS4115 11ga	5 ft.	<b>55.95</b>	
PR2PMS41110 11ga	10 ft.	<b>58.95</b>	
PR2PMS41125 11ga	25 ft.	<b>104.95</b>	
PR2PMS41150 11ga	50 ft.	<b>148.95</b>	
PR2PMS411100 11ga	100 ft.	<b>254.50</b>	
PR4PMS81310 13ga	10 ft.	<b>102.50</b>	
PR4PMS81325 13ga	25 ft.	<b>134.95</b>	
PR4PMS81350 13ga	50 ft.	<b>207.95</b>	
PR4PMS813100 13ga	100 ft.	<b>324.95</b>	

**Excellines  
1/4" Phone to 1/4" Phone**

PRPMPM123 12ga	3 ft.	<b>38.95</b>	
PRPMPM125 12ga	5 ft.	<b>34.95</b>	
PRPMPM1210 12ga	10 ft.	<b>48.95</b>	
PRPMPM1225 12ga	25 ft.	<b>46.50</b>	
PRPMPM1250 12ga	50 ft.	<b>71.95</b>	
PRPMPM12100 12ga	100 ft.	<b>129.50</b>	
PRPMPM143 14ga	3 ft.	<b>26.95</b>	
PRPMPM1410 14ga	10 ft.	<b>34.95</b>	
PRPMPM1425 14ga	25 ft.	<b>49.95</b>	
PRPMPM1450 14ga	50 ft.	<b>49.50</b>	
PRPMPM14100 14ga	100 ft.	<b>68.95</b>	
PRPMPM163 16ga	3 ft.	<b>26.95</b>	
PRPMPM1610 16ga	10 ft.	<b>29.95</b>	
PRPMPM1625 16ga	25 ft.	<b>39.95</b>	
PRPMPM1650 16ga	50 ft.	<b>56.95</b>	

**Excellines  
2-Conductor Speakon to Speakon**

PRSS1210 12ga	10 ft.	<b>37.95</b>	
PRSS1225 12ga	25 ft.	<b>51.95</b>	
PRSS1250 12ga	50 ft.	<b>75.95</b>	
PRSS12100 12ga	100 ft.	<b>129.95</b>	
PRSS143 14ga	3 ft.	<b>44.95</b>	
PRSS1410 14ga	10 ft.	<b>47.95</b>	
PRSS1425 14ga	25 ft.	<b>39.95</b>	
PRSS1450 14ga	50 ft.	<b>57.50</b>	
PRSS163 16ga	3 ft.	<b>37.95</b>	
PRSS1610 16ga	10 ft.	<b>42.95</b>	
PRSS1625 16ga	25 ft.	<b>42.95</b>	
PRSS1650 16ga	50 ft.	<b>43.95</b>	

**"Power Plus"  
4-Conductor**

PRS4S4115 11ga	5 ft.	<b>56.50</b>	
PRS4S41110 11ga	10 ft.	<b>76.95</b>	
PRS4S41125 11ga	25 ft.	<b>119.95</b>	
PRS4S41150 11ga	50 ft.	<b>166.95</b>	
PRS4S411100 11ga	100 ft.	<b>288.95</b>	
PRS4S41410 14ga	10 ft.	<b>39.95</b>	
PRS4S41425 14ga	25 ft.	<b>68.50</b>	
PRS4S41450 14ga	50 ft.	<b>114.95</b>	

**"Power Plus"  
4-Conductor**

PRS8S81310 13ga	10 ft.	<b>144.50</b>	
PRS8S81325 13ga	25 ft.	<b>166.95</b>	
PRS8S81350 13ga	50 ft.	<b>269.95</b>	
PRS8S813100 13ga	100 ft.	<b>336.50</b>	

**SPEAKER CABLES (cont'd)**

**Excellines  
Banana to Banana**

PRBB1210 12ga	10 ft.	<b>51.95</b>	
PRBB1225 12ga	25 ft.	<b>47.50</b>	
PRBB1250 12ga	50 ft.	<b>69.95</b>	
PRBB12100 12ga	100 ft.	<b>128.95</b>	
PRBB143 14ga	3 ft.	<b>29.95</b>	
PRBB1410 14ga	10 ft.	<b>35.95</b>	
PRBB1425 14ga	25 ft.	<b>49.95</b>	
PRBB1450 14ga	50 ft.	<b>49.50</b>	
PRBB1610 16ga	10 ft.	<b>29.95</b>	
PRBB1625 16ga	25 ft.	<b>39.95</b>	
PRBB1650 16ga	50 ft.	<b>36.95</b>	

**Excellines  
Speaker Dual Banana to TS Phone**

PRBPM1210 12ga	10 ft.	<b>44.95</b>	
PRBPM1225 12ga	25 ft.	<b>39.95</b>	
PRBPM1250 12ga	50 ft.	<b>61.95</b>	
PRBPM12100 12ga	100 ft.	<b>111.95</b>	
PRBPM143 14ga	3 ft.	<b>25.95</b>	
PRBPM1410 14ga	10 ft.	<b>29.95</b>	
PRBPM1425 14ga	25 ft.	<b>44.95</b>	
PRBPM1450 14ga	50 ft.	<b>42.95</b>	
PRBPM163 16ga	3 ft.	<b>23.95</b>	
PRBPM1610 16ga	10 ft.	<b>26.95</b>	
PRBPM1625 16ga	25 ft.	<b>34.95</b>	
PRBPM1650 16ga	50 ft.	<b>32.50</b>	
PRBPF161 16ga	1 ft.	<b>24.95</b>	
PRBPM12100 12ga	100 ft.	<b>111.95</b>	

**Excellines  
Banana to Speakon**

PRBS1210 12ga	10 ft.	<b>48.95</b>	
PRBS1225 12ga	25 ft.	<b>43.95</b>	
PRBS1250 12ga	50 ft.	<b>64.95</b>	
PRBS12100 12ga	100 ft.	<b>111.95</b>	
PRBS1410 14ga	10 ft.	<b>34.95</b>	
PRBS1425 14ga	25 ft.	<b>49.95</b>	
PRBS1450 14ga	50 ft.	<b>46.50</b>	
PRBS1610 16ga	10 ft.	<b>29.95</b>	
PRBS1625 16ga	25 ft.	<b>39.95</b>	
PRBS1650 16ga	50 ft.	<b>34.95</b>	

**Excellines  
Banana to Speakon 2**

PR2BS4116 11ga	6 ft.	<b>49.95</b>	
PR2BS41110 11ga	10 ft.	<b>59.95</b>	
PR2BS41125 11ga	25 ft.	<b>106.95</b>	
PR2BS41150 11ga	50 ft.	<b>147.50</b>	
PR2BS411100 11ga	100 ft.	<b>253.50</b>	

**Excellines  
Banana to Speakon 2**

PRPMS1210 12ga	10 ft.	<b>53.95</b>	
PRPMS1225 12ga	25 ft.	<b>49.50</b>	
PRPMS1250 12ga	50 ft.	<b>72.95</b>	
PRPMS12100 12ga	100 ft.	<b>129.95</b>	
PRPMS143 14ga	3 ft.	<b>35.95</b>	
PRPMS146 14ga	6 ft.	<b>37.95</b>	
PRPMS1410 14ga	10 ft.	<b>41.95</b>	
PRPPS1425 14ga	25 ft.	<b>49.95</b>	
PREPMS1450 14ga	50 ft.	<b>52.95</b>	
PRPMS163 16ga	3 ft.	<b>33.95</b>	
PRPMS166 16ga	6 ft.	<b>33.95</b>	
PRPMS1610 16ga	10 ft.	<b>34.95</b>	
PRPMS1625 16ga	25 ft.	<b>46.95</b>	
PRPMS1650 16ga	50 ft.	<b>39.95</b>	



**WHIRLWIND SPEAKER CABLES**

**TS to TS**

WHSK110G12 12ga	10 ft.	<b>24.95</b>	
WHSK125G12 12ga	25 ft.	<b>39.95</b>	
WHSK150G12 12ga	50 ft.	<b>63.50</b>	
WHSK1100G12 12ga	100 ft.	<b>109.95</b>	
WHSK110G14 14ga	10 ft.	<b>23.95</b>	
WHSK125G14 14ga	25 ft.	<b>29.95</b>	
WHSK150G14 14ga	50 ft.	<b>39.95</b>	
WHSK1100G14 14ga	100 ft.	<b>69.95</b>	

**Speakon to Phone TS**

	WHSK225G12 12ga	25 ft.	<b>39.95</b>
	WHSK250G12 12ga	50 ft.	<b>66.50</b>
	WHSK2100G12 12ga	100 ft.	<b>114.95</b>

**Dual Banana to Phone TS**

WHSK310G12 12ga	10 ft.	<b>29.50</b>	
WHSK325G12 12ga	25 ft.	<b>34.95</b>	
WHSK350G12 12ga	50 ft.	<b>58.95</b>	
WHSK3100G12 12ga	100 ft.	<b>106.50</b>	
WHSK310G14 14ga	10 ft.	<b>19.95</b>	
WHSK325G14 14ga	25 ft.	<b>23.95</b>	
WHSK350G14 14ga	50 ft.	<b>38.50</b>	
WHSK3100G14 14ga	100 ft.	<b>67.50</b>	
WHSK350G16 16ga	50 ft.	<b>29.95</b>	

**Dual Banana to Speakon**

	WHSK425G12 12ga	25 ft.	<b>37.95</b>
	WHSK450G12 12ga	50 ft.	<b>62.50</b>
	WHSK4100G12 12ga	25 ft.	<b>109.95</b>

**Speakon to Speakon**

WHSK510G12 12ga	10 ft.	<b>27.50</b>	
WHSK525G12 12ga	25 ft.	<b>42.95</b>	
WHSK550G12 12ga	50 ft.	<b>66.95</b>	
WHSK5100G12 12ga	100 ft.	<b>114.95</b>	

**BLUE CABLES**

**Recommended for Baby Bottle and Blueberry Mics**

	BLBC (Blueberry)	20 ft.	<b>29.00</b>
--	------------------	--------	--------------

**Recommended for Dragonfly, Dragonfly Deluxe and Mouse Mics**

	BLCC (Cranberry)	20 ft.	<b>39.00</b>
--	------------------	--------	--------------

**Recommended for Kiwi, Cactus and Bottle Mics**

	BLKC (Kiwi)	20ft.	<b>49.00</b>
--	-------------	-------	--------------

**APOGEE**

**Apogee Wyde-Eye AES/EBU**

APWEXX.5	0.5 m	<b>53.95</b>	
APWEXX1	1 m	<b>62.95</b>	
APWEXX2	2 m	<b>69.95</b>	
APWEXX3	3 m	<b>79.95</b>	
APWEXX5	5 m	<b>89.95</b>	
APWEXX10	10 m	<b>98.95</b>	

**Apogee Wyde-Eye S/PDIF**

	APWERR.5	0.5 m	<b>53.95</b>
	APWERR1	1 m	<b>62.95</b>
	APWERR2	2 m	<b>69.95</b>
	APWERR3	3 m	<b>79.95</b>
	APWERR5	5 m	<b>89.95</b>
	APWERR10	10 m	<b>98.95</b>

**APOGEE (cont'd)**

**Apogee Wyde Fiber Optic**

APWEGP1	1 m	<b>62.95</b>	
APWEGP2	2 m	<b>79.95</b>	
APWEGP3	3 m	<b>98.95</b>	
APWEGP5	5 m	<b>124.95</b>	

**Apogee Wyde-Eye Word Clock**

	APWEBB.5	0.5 m	<b>53.95</b>
	APWEBB1	1 m	<b>62.95</b>
	APWEBB2	2 m	<b>69.95</b>
	APWEBB3	3 m	<b>79.95</b>
	APWEBB5	5 m	<b>89.95</b>
	APWEBB10	10 m	<b>98.95</b>

**ANTENNA CABLES**

**Sennheiser**

**50 ohm BNC to BNC**

	SEBB1	1 ft.	<b>7.95</b>
--	-------	-------	-------------

**Shure**

**50 ohm BNC to BNC**

	SHPA725	10ft.	<b>29.95</b>
--	---------	-------	--------------

**Hosa Antenna Cables**

HOBAC1	1 ft.	<b>4.95</b>	
HOBAC1.5	1.5 ft.	<b>5.50</b>	
HOBAC3	3 ft.	<b>5.95</b>	
HOBAC6	6 ft.	<b>6.95</b>	
HOBAC10	10 ft.	<b>7.95</b>	
HOBAC15	15 ft.	<b>9.95</b>	
HOBAC25	25 ft.	<b>12.95</b>	
HOBAC50	50 ft.	<b>19.95</b>	
HOBAC100	100 ft.	<b>34.95</b>	

**AUDIO TECHNICA INTERCONNECTS**

**XLR to TS Phone**

AUAT831110	10 ft.	<b>9.99</b>	
AUAT831125	25 ft.	<b>13.95</b>	

**XLR/M to XLR/F**

	AUAT83141.5	1.5 ft.	<b>9.49</b>
	AUAT83141.5R angled	1.5 ft.	<b>17.48</b>
	AUAT83143	3 ft.	<b>9.99</b>
	AUAT83146	6 ft.	<b>12.99</b>
	AUAT831410	10 ft.	<b>14.95</b>
	AUAT831420	20 ft.	<b>18.95</b>
	AUAT831420R angled	20 ft.	<b>21.95</b>
	AUAT831425	25 ft.	<b>19.99</b>
	AUAT831430	30 ft.	<b>22.95</b>
	AUAT831450	50 ft.	<b>24.95</b>
	AUAT8314100	100 ft.	<b>38.50</b>

**AUDIO TECHNICA SPEAKER CABLES**

**TS to TS**

AUAT6903	3 ft.	<b>8.95</b>	
AUAT6906	6 ft.	<b>9.95</b>	
AUAT69010	10 ft.	<b>11.95</b>	
AUAT69015	15 ft.	<b>13.95</b>	
AUAT69025	25 ft.	<b>17.95</b>	
AUAT69050	50 ft.	<b>26.95</b>	

**AUDIO TECHNICA (cont'd)**

**Dual Banana to TS**

	AUAT69010B	10 ft.	<b>14.95</b>
	AUAT69015B	15 ft.	<b>16.95</b>
	AUAT69025B	25 ft.	<b>19.95</b>
	AUAT69050B	50 ft.	<b>28.95</b>

**CANARE**

**Starsquad XLR/M to XLR/F**

	CAXMXF3	3 ft.	<b>16.95</b>
	CAXMXF6	6 ft.	<b>19.95</b>
	CAXMXF10	10 ft.	<b>24.95</b>
	CAXMXF15	15 ft.	<b>29.95</b>
	CAXMXF25	25 ft.	<b>39.95</b>
	CAXMXF50	50 ft.	<b>49.95</b>

**XLR Breakaway Cable w/Monitor Out**

	CABACX15	15 ft.	<b>189.95</b>
	CABACX25	25 ft.	<b>199.95</b>

**MOGAMI GOLD**

**XLR/M to XLR/F**

	MOS3 Studio	3 ft.	<b>31.95</b>
	MOS5 Studio	5 ft.	<b>33.95</b>
	MOS15 Studio	15 ft.	<b>44.95</b>
	MOS25 Studio	25 ft.	<b>55.95</b>
	MOS50 Studio	50 ft.	<b>89.95</b>

**XLR/M to XLR/F**

	MOS20 Stage	20 ft.	<b>56.95</b>
	MOS30 Stage	30 ft.	<b>74.95</b>
	MOS50Q Stage	50 ft.	<b>109.95</b>

**AES/EBU**

	MOAESEBU3	3 ft.	<b>39.95</b>
	MOAESEBU6	6 ft.	<b>46.95</b>
	MOAESEBU12	12 ft.	<b>59.95</b>

**Instrument Phone to Phone**

	MOI15	15 ft.	<b>43.95</b>
	MOI18	18 ft.	<b>49.95</b>
	MOI25	25 ft.	<b>49.95</b>

**Instrument Phone to Right Angle Phone**

	MOIRA10	10 ft.	<b>43.95</b>
	MOIRA18	18 ft.	<b>49.95</b>
	MOIRA25	25 ft.	<b>53.95</b>

**Balanced Phone to XLR/M**

	MOTRSXLRM3	3 ft.	<b>32.95</b>
	MOTRSXLRM6	6 ft.	<b>35.95</b>
	MOTRSXLRM10	10 ft.	<b>38.95</b>
	MOTRSXLRM15	15 ft.	<b>46.95</b>
	MOTRSXLRM20	20 ft.	<b>51.95</b>

**Balanced Phone to XLR/F**

	MOTRSXLRF3	3 ft.	<b>32.95</b>
	MOTRSXLRF6	6 ft.	<b>35.95</b>
	MOTRSXLRF10	10 ft.	<b>38.95</b>
	MOTRSXLRF15	15 ft.	<b>46.95</b>
	MOTRSXLRF20	20 ft.	<b>51.95</b>

**Balanced Phone to Phone**

	MOTRSTRS3	3 ft.	<b>40.95</b>
	MOTRSTRS6	6 ft.	<b>44.95</b>
	MOTRSTRS10	10 ft.	<b>48.95</b>
	MOTRSTRS20	20 ft.	<b>61.95</b>

**Unbalanced Phone to Phone**

	MOTST53	3 ft.	<b>29.95</b>
	MOTST56	6 ft.	<b>34.95</b>

**DIGITAL AUDIO CABLES**

**XD1 Series Digital Toslink**

COCTTXD13	3 ft.	<b>14.95</b>	
COCTTXD16	6 ft.	<b>18.95</b>	
COCTTXD112	12 ft.	<b>13.95</b>	
COCTTXD125	25 ft.	<b>28.95</b>	

**XLR Male-Female (AES-EBU)**

COCAES3	3 ft.	<b>19.95</b>	
COCAES6	6 ft.	<b>22.95</b>	
COCAES10	10 ft.	<b>24.95</b>	
COCAES25	25 ft.	<b>44.95</b>	
COCAES50	50 ft.	<b>59.95</b>	

**MINI AUDIO CABLES**

**S/PDIF RCA Male to Male**

COCSPDIFXD13	3 ft.	<b>19.95</b>	
COCSPDIFXD16	6 ft.	<b>27.95</b>	
COCSPDIFXD11	12 ft.	<b>29.95</b>	

**3.5mm Mini Male to Male**

COCSMMMM3	3 ft.	<b>2.49</b>	
COCSMMMM6	6 ft.	<b>3.39</b>	
COCSMMMM10	10 ft.	<b>3.89</b>	
COCSMMMM25	25 ft.	<b>4.89</b>	

**3.5mm Stereo Mini Male to Male**

COCSMMSMM3	3 ft.	<b>2.49</b>	
COCSMMSMM6	5 ft.	<b>3.39</b>	
COCSMMSMM10	10 ft.	<b>3.89</b>	
COCSMMSMM25	25 ft.	<b>4.89</b>	

**PHONE CABLES**

**1/4" Male-Male**

COCPPM1.5	1.5 ft.	<b>3.99</b>	
COCPPM3	3 ft.	<b>4.49</b>	
COCPPM6	6 ft.	<b>5.49</b>	
COCPPM10	10 ft.	<b>6.49</b>	
COCPPM25	25 ft.	<b>8.99</b>	

**Stereo 1/4" Male-Male**

COCSPMSPM1.5	1.5 ft.	<b>5.99</b>	
COCSPMSPM3	3 ft.	<b>6.99</b>	
COCSPMSPM6	6 ft.	<b>7.99</b>	
COCSPMSPM10	10 ft.	<b>8.99</b>	
COCSPMSPM25	25 ft.	<b>11.99</b>	

**1/4" Male to RCA Male**

COCPMRM3Q	3 ft.	<b>6.99</b>	
COCPMRM6	6 ft.	<b>5.29</b>	
COC2R2R10	10 ft.	<b>5.49</b>	
COC2R2R25	25 ft.	<b>6.99</b>	

**RCA CABLES**

**Dual RCA Male-Male**

COC2R2R3	3 ft.	<b>3.59</b>	
COC2R2R6	6 ft.	<b>4.19</b>	
COC2R2R10	10 ft.	<b>4.99</b>	
COC2R2R25	25 ft.	<b>6.99</b>	

**RCA CABLES (cont'd)**

**XHD (Extreme High Definition) Series Dual RCA Audio Male-Male**

COC2R2RX3A3	3 ft.	<b>19.95</b>	
COC2R2RX3A6	6 ft.	<b>24.95</b>	
COC2R2RX3A12	12 ft.	<b>32.95</b>	
COC2R2RX3A25	25 ft.	<b>44.95</b>	

**RCA Male-Male**

COCRR1.5	1.5 ft.	<b>7.50</b>	
COCRR3	3 ft.	<b>4.99</b>	
COCRR6	6 ft.	<b>6.99</b>	
COCRR10	10 ft.	<b>7.99</b>	
COCRR25	25 ft.	<b>9.99</b>	
COCRR50	50 ft.	<b>12.99</b>	
COCRR100	100 ft.	<b>39.95</b>	

**XLR CABLES**

**XLR Male to 3.5mm Mini Male**

COCMMXM3	3 ft.	<b>8.99</b>	
COCMMXM6	6 ft.	<b>9.99</b>	
COCMMXM10	10 ft.	<b>11.99</b>	
COCMMXM25	25 ft.	<b>14.99</b>	

**XLR Male to Stereo 3.5mm Mini Male**

COCSMMXM3	3 ft.	<b>11.99</b>	
COCSMMXM6	6 ft.	<b>12.99</b>	
COCSMMXM10	10 ft.	<b>14.99</b>	
COCSMMXM25	25 ft.	<b>18.99</b>	

**XLR Male to 3.5mm Mini Female**

COCMFXM3	3 ft.	<b>8.99</b>	
COCMFXM6	6 ft.	<b>9.99</b>	
COCMFXM10	10 ft.	<b>11.99</b>	
COCMFXM25	25 ft.	<b>14.99</b>	

**XLR Female to 3.5mm Mini Male**

COCMMXF3	3 ft.	<b>8.99</b>	
COCMMXF6	6 ft.	<b>9.99</b>	
COCMMXF10	10 ft.	<b>11.99</b>	
COCMMXF25	25 ft.	<b>14.99</b>	

**XLR Female to Stereo 3.5mm Mini Male**

COCSMMXF1.5	1.5 ft.	<b>10.99</b>	
COCSMMXF3	3 ft.	<b>11.99</b>	
COCSMMXF6	6 ft.	<b>12.99</b>	
COCSMMXF10	10 ft.	<b>14.99</b>	
COCSMMXF25	25 ft.	<b>18.99</b>	

**XLR Female to 3.5mm Mini Female**

COCMFXF3	3 ft.	<b>8.99</b>	
COCMFXF6	6 ft.	<b>9.99</b>	
COCMFXF10	10 ft.	<b>11.99</b>	
COCMFXF25	25 ft.	<b>14.99</b>	

**XLR Male to RCA Male**

COCRMXM3	3 ft.	<b>8.99</b>	
COCRMXM6	6 ft.	<b>9.99</b>	
COCRMXM10	10 ft.	<b>11.99</b>	
COCRMXM25	25 ft.	<b>14.99</b>	

**XLR Male to RCA Female**

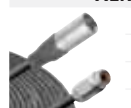
COCRFXM3	3 ft.	<b>8.99</b>	
COCRFXM6	6 ft.	<b>9.99</b>	
COCRFXM10	10 ft.	<b>11.99</b>	
COCRFXM25	25 ft.	<b>14.99</b>	

**XLR CABLES (cont'd)**

**XLR Female to RCA Male**

COCRMXF3	3 ft.	<b>8.99</b>	
COCRMXF6	6 ft.	<b>9.99</b>	
COCRMXF10	10 ft.	<b>11.99</b>	
COCRMXF25	25 ft.	<b>14.99</b>	

**XLR Female to RCA Female**

COCRFXF3	3 ft.	<b>8.99</b>	
COCRFXF6	6 ft.	<b>9.99</b>	
COCRFXF10	10 ft.	<b>11.99</b>	
COCRFXF25	25 ft.	<b>14.99</b>	

**XLR Male to 1/4" Male**

COCPMXM3	3 ft.	<b>9.99</b>	
COCPMXM6	6 ft.	<b>10.99</b>	
COCPMXM10	10 ft.	<b>12.99</b>	
COCPMXM25	25 ft.	<b>15.99</b>	

**XLR Female to 1/4" Male**

COCPMXF3	3 ft.	<b>9.99</b>	
COCPMXF6	6 ft.	<b>10.99</b>	
COCPMXF10	10 ft.	<b>12.99</b>	
COCPMXF25	25 ft.	<b>15.99</b>	

**XLR Female to Stereo 1/4" Male**

COCSPMXF3	3 ft.	<b>10.49</b>	
COCSPMXF6	6 ft.	<b>11.99</b>	
COCSPMXF10	10 ft.	<b>12.99</b>	
COCSPMXF25	25 ft.	<b>17.99</b>	

**XLR Male to 1/4" Stereo Male**

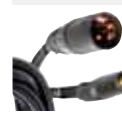
COCSPMXM3	3 ft.	<b>9.99</b>	
COCSPMXM6	6 ft.	<b>10.99</b>	
COCSPMXM10	10 ft.	<b>12.99</b>	
COCSPMXM25	25 ft.	<b>15.99</b>	

**XLR Male to 1/4" Female**

COCPFXM3	3 ft.	<b>9.99</b>	
COCPFXM6	6 ft.	<b>10.99</b>	
COCPFXM10	10 ft.	<b>12.99</b>	
COCPFXM25	25 ft.	<b>15.99</b>	

**XLR Female to 1/4" Female**

COCPFXF3	3 ft.	<b>9.99</b>	
COCPFXF6	6 ft.	<b>10.99</b>	
COCPFXF10	10 ft.	<b>12.99</b>	
COCPFXF25	25 ft.	<b>15.99</b>	

**THE CABLE ORGANIZER**

The Cable Organizer is the easiest, most effective way to reduce messy, cluttered wiring configurations with a Single Cable. You can organize numerous cables into one neat, single, no-mess solution. It is available in a retail polybag, which includes the patented insertion tool, and also in rolls, for industrial and commercial applications.



- 8 Feet** 3/4", 1", or 1-1/4" Cable Zipper (Beige, Black, or White)..... **\$13.95 each**
- 64 Feet** 3/4", 1", or 1-1/4" Cable Zipper (Beige, Black, or White)..... **\$64.95 each**
- 100 Feet** 3/4", 1", or 1-1/4" Cable Zipper (Beige, Black, or White)..... **\$84.95 each**

**OPTICAL MEDIA**

**HHB CD-R**



HHCDR74G	650MB Gold with jewel case	<b>1.95</b>
HHCDR80IP	700MB Gold white Inkjet printable	<b>1.95</b>
HHCDR80IPB	CD-R 80-min Inkjet 50-pack	<b>205.95</b>
HHCDR80TPB	CD-R 80-min thermal print 50-pack	<b>206.95</b>
HHCDRW80	700MB CD-RW Disc	<b>1.50</b>

**HHB DVD-R**

HHB 4.7GB (120 Minutes) 8x DVD-R Discs, Inkjet Printable-50 Pack



HHDVD47GBIB	DVD-R 4.7GB	<b>349.95</b>
-------------	-------------	---------------

**HHB DVD-RW**

HHB 4.7GB (120 Minutes) 2x DVD-RW Discs



DVDRW47GBMIN	DVD-RW 4.7GB	<b>7.50</b>
--------------	--------------	-------------

**HHB DVD+R**



HHVDPR4	DVD+R 4.7GB	<b>2.95</b>
HHVD47GBG	DVD-R 4.7GB Inkjet	<b>1.95</b>
HHVD47GBTB	DVD-R 4.7GB Thermal 50-pack	<b>324.95</b>

**HHB DVD**

HHVD47GBG	DVD-RAM Type2 4.7GB	<b>17.50</b>
-----------	---------------------	--------------

HHVD47GBTB	DVD-RAM Type4 9.4GB	<b>27.50</b>
------------	---------------------	--------------

**CASSETTE TAPES**

**Maxell Communicator Series**

Normal Bias, Low Noise Audio Cassettes (includes case and labels, good for speech recording)



MACOM30	30 min	<b>.79</b>
MACOM45	45 min	<b>.85</b>
MACOM60	60 min	<b>.89</b>
MACOM90	90 min	<b>1.19</b>
MACOM120	120 min	<b>1.79</b>

**Maxell Duplicator Series**

Normal Bias, Low Noise Audio Cassettes (unlabeled shell & no case, good for speech recording)



MADUP30	30 min	<b>.69</b>
MADUP45	45 min	<b>.89</b>
MADUP60	60 min	<b>.71</b>
MADUP90	90 min	<b>.95</b>

**CASSETTE TAPES (cont'd)**

**Maxell MS XLII Series**

High output & wide dynamic range  
High bias XLII formulation



MAXL290	90 min	<b>1.95</b>
---------	--------	-------------

**Sony Cassettes**

Sony Normal Bias High Fidelity



SOC60HFL	60 min	<b>.59</b>
SOC90HFL	90 min	<b>.69</b>
SOC120HFL	120 min	<b>1.39</b>

**DAT TAPES**

**HHB DAT Tapes**

Professional High-Performance DAT Tapes

HHDAT15	15 min	<b>4.49</b>
HHDAT35	35 min	<b>4.99</b>
HHDAT50	50 min	<b>5.40</b>
HHDAT65	65 min	<b>6.49</b>
HHDAT95	95 min	<b>7.49</b>
HHDAT125	125 min	<b>7.99</b>

**Maxell DAT Tapes**

Professional Digital Audio Tape



MAR65DA	65 min	<b>4.79</b>
MAR95DA	95 min	<b>5.50</b>
MAR125DA	120 min	<b>5.95</b>

**Sony DAT Tapes**

Professional Digital Audio Tape

SOPDP15C	15 min	<b>4.19</b>
SOPDP65C	65 min	<b>6.29</b>
SOPDP95C	95 min	<b>7.69</b>
SOPDP125C	125 min	<b>7.99</b>

**DTRS & ADAT**

**HHB DTRS**

Double coated. Tascam approved.

HHDA113	113 min	<b>18.50</b>
HHDA60	60 min	<b>18.50</b>

**HHB ADAT**

Alesis-approved ADAT tape. Designed specifically for rigorous music production.

HHADAT45	45 min	<b>9.95</b>
----------	--------	-------------

**MINI-DISC**

**HHB Mini-Disc**

Professional Mini-Disc

HHMD74	74 min	<b>1.95</b>
HHMD80	80 min	<b>1.95</b>
HHMD140	data disc for multi-track recorders	<b>14.99</b>

**Sony Mini-Disc**

SOHMD1GL	Hi-MD blank Mini-Disc	<b>4.99</b>
SOMDW80PL	Premium Gold Mini-Disc	<b>1.69</b>
SOMD8HCL	Mini-Disc Head Cleaner	<b>12.99</b>

**COMPACT FLASH**

**Lexar**



LECFP21GB	80x Compact Flash 1GB	<b>26.95</b>
LECFP22GB	80x Compact Flash 2GB	<b>39.95</b>
LECF133X1GB	133X Compact Flash 1GB	<b>34.99</b>
LECF133X2GB	133X Compact Flash 2GB	<b>54.99</b>
LECF133X4GB	133X Compact Flash 4GB	<b>99.99</b>

**MICRO DRIVES**

**Hitachi Microdrives**

Microdrive Cards

HI3GB	3GB	<b>109.95</b>
HI4GB	4GB	<b>124.95</b>
HI6GB	6GB	<b>164.95</b>

**JEWEL CASES/SLEEVES**

**Merit-Line**



MEPCSW25	paper CD sleeve w/window 25 pack	<b>1.39</b>
METCSW25	Tyvek paper CD sleeve w/window 25 pack	<b>3.99</b>
MECSJC50	slim colored jewel case 50 pack	<b>8.99</b>
MEBSJC50	slim black jewel cases 50 pack	<b>9.99</b>

**TDK**

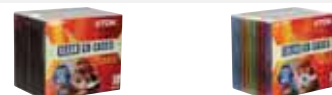

TDJC10CL	clear jewel cases 10-pack	<b>3.95</b>
TDJC10C	colored jewel cases 10-pack	<b>3.95</b>

**BATTERIES**

**Duracell**



DU9V	single 9V battery	<b>1.99</b>
DUAAC	4-pack AA batteries	<b>.69</b>
DUAAC	2-pack AAA batteries	<b>.89</b>
DUC	2-pack C batteries	<b>1.19</b>
DUD	2-pack D batteries	<b>1.29</b>

**Monster Power**



MOAARA42850	AA high performance 4-pack	<b>1.39</b>
MOAARA82850	AA high performance 8-pack	<b>7.95</b>
MOMBALKA4	D high performance 4-pack	<b>7.95</b>
MOMBALKA8	D high performance 8-pack	<b>9.95</b>
MOMBCALKA4	C high performance 4-pack	<b>7.95</b>
MOMBCALKA8	C high performance 8-pack	<b>9.95</b>



**RIP-TIE**  
**CableCatch**

5-pack 1x4" black

The CableCatch allows users to change or move cables easily just by pulling the tab. Adhesive backing permanently adheres to any smooth, flat surface.

#RICC45B  
**\$13.50**



**CinchStrap 10-pack**  
1/2x10" black

The CinchStrap is a heavy-duty utility strap made with the highest-quality materials, and a double-stitched design that assures strength and dependability.

**Cinch Strap** 10-pack 1/2x7" black #RICSEG710B ..... **\$29.95**

#RICSEG1010B  
**\$29.95**

**RAXXESS**  
**Cable Ties**

100-piece pack of strong plastic cable ties are designed to gather large or long lengths of cables.

8" reusable ties #RACT1008R..... **\$13.95**

8" single-use cable ties #RACT1008 ..... **\$9.95**

4" single-use cable ties #RACT1004 ..... **\$8.95**



**GAFFER CLOTH TAPE**

This standard in professional gaffer's cloth tape is used for securing and holding audio wires, overhead lighting, set and stage decoration. (2" x 60 yds.)

black #GBGT60B, gray #GBGT60G ... **\$19.95** white #GBGT60W .. **\$19.95**

**RIP-TIE**  
**CableCarrier**

2-pack 1x6" black

The CableCarrier attaches to a belt loop or tool belt for easy access to extra cables. It can also be used as a temporary hanger for cable runs during events, construction, or installations.

#RICCC62B  
**\$6.95**



**CableWrap 10-pack 1x14" black**



Patented design, one end permanently attaches to the cable and the other end has a pull-tab to free the Rip-Tie with one hand.

#RICW1410B  
**\$26.95**

**SPEEDOTRON**  
**Cord Lox**

The Speedotron Cord Lox bundles cables and cords while in storage or transport.

Easily wraps around the gathered cables and locks into place. Set of 6.

#SPLC6BL  
**\$8.95**



**BOGEN/MONFROTTO**

**Cable Path Tape**



Premium cloth "CABLE" adhesive tape holds firm for extended periods, on most surfaces. Allows smooth tunnel runs.

4" x 30 yds.

#PECPT430 ..... **\$23.95**

6" x 30 yds.

#PECPT630 ..... **\$38.95**

**BOGEN/MONFROTTO**

**Caution Cable Tape**

Premium cloth "CAUTION" adhesive tape holds firm for extended periods on most surfaces. (3" x 60 yds.)

(Orange) #PECCT360FO ..... **\$37.99**



#SAS46G  
**\$29.95**

**SAFCORD**

**Cord/Cable Protector**

Secures electrical cords to looped commercial grade carpet. Its hook-and-loop method replaces tape, locking cords in place without adhesives.



**PERMACEL**

**Console Tape**

Permacel white console paper tape is ideal for use as a disposable scribble strip on consoles, mixers and road cases. 1" wide x 60 yards long roll.

#PEPT160W ..... **\$7.29**

#PEPT160B ..... **\$7.29**



**LEATHERMAN**

**Charge ALX**



Multi-tool featuring: contoured titanium grip handles, a 154 CM steel knife, (3) bit drivers, wire cutters, all-locking implements; equipped with a total of 21 components.

#LECALXN  
**\$99.85**

**GTC-INDUSTRIES**

**NP 1 Noise Plug**

Precision Pink Noise Generator with phantom power detector and XLR connector enclosure. No batteries required.

#GTNP1  
**\$39.95**



#GTTP1  
**\$49.95**

**GTC-INDUSTRIES**

**Tone Plug**

Audio Test Tone Generator with 11 audio system test functions, simple push-button design, XLR connector enclosure. No batteries required.



**LEATHERMAN**

**Wave Tool**

The Leatherman Wave Tool features (4) locking blades, (7) interior tools, pliers, and cutters for a total of 18 functions and comes with comfortable handles and leather sheath belt clip.

#LEWLC  
**\$74.85**



**Fuse Tool**

The Leatherman Fuse Tool has 12 implements with 14 functions and includes Leatherman's extra-long knife blade and three extended screwdrivers.

#LEFLC  
**\$39.85**



**Leather Pouch** #LEPSLFK ..... **\$5.95**

**PORTABRACE**  
**SK Series Pouches**

#POSK3P  
**\$59<sup>95</sup>**

The PortaBrace SK-3P Pouch holds many of the Leatherman brand multi-use tools, permanent markers, and fine adjustment tools.



**NITE IZE**  
**Mini Pock-Its**

#NIMPIB  
**\$10<sup>95</sup>**

The Nite Ize Mini Pock-Its are constructed of rugged, water-resistant material accommodating most barrel shaped mini-flashlights, and most brands and sizes of multi-tools.

**NITE IZE**  
**Headband**

#NIHBB  
**\$5<sup>49</sup>**

The Nite Ize Headband allows you to turn your AA or AAA battery-powered, mini flashlight into a versatile head lamp.



**Magnetic Clip**

The Nite Ize Magnetic Clip allows you to place your mini flashlight in common areas to keep it easily accessible.

#NIMCAA  
**\$3<sup>89</sup>**

**NITE IZE**  
**Lite Bite**

#NILBAA  
**\$4<sup>99</sup>**

The Nite Ize Lite Bite provides a safer, more comfortable way to hold a mini flashlight in your mouth. 28" accessory cord included.



**NITE IZE**  
**Flashlite Friend**

#NIFFAA  
**\$7<sup>49</sup>**

Combines a clear housing and four easily adjustable flexible legs, pin pointing light placement without having to hold on.



**LED & Switch**  
**Upgrade Kit**

#NILEDCAK  
**\$9<sup>95</sup>**

The two-pin L.E.D. module replaces the incandescent bulb, and an "On Demand" push-button on/off switch replaces the end cap of your mini flashlight.

**Fiber Optic Adapter**  
**The Nite Ize Fiber Optic**

#NIFOA7AA  
**\$6<sup>99</sup>**

Adapters allow you to turn your mini flashlight into a precision light-bending instrument. Non-conductive, non-magnetic, and non-electrical wand.



**LUMIN-EZE**  
**Mini Clamp-On Light**

Ideal for console or rack mounting in DJ, live sound recording, and any application where additional lighting is necessary.  
(Halogen) #LULEMINIH ..... **\$39.50**  
(Incandescent) #LULEMINI ..... **\$29.95**



**Clamp-On Gooseneck**

Designed for console or rack-mounting applications, featuring a clamp that opens up to 2" wide. 12V power supply is included.  
(Halogen) #LULE1S12H ..... **\$53.95**  
(Incandescent) #LULE1S12 ..... **\$47.95**

**MAG-LITE**  
**Mini Flashlight**

#MAMM2AA  
**\$12<sup>95</sup>**

The Mag-Lite Mini flashlight comes with a nylon belt holster, spare bulb in the tail cap, and uses supplied AA batteries.

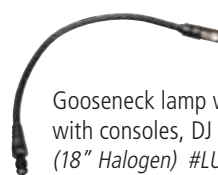

**LUMIN-EZE**  
**BNC Lamp**

Gooseneck lamp with rotating shade designed for connectivity with consoles, DJ mixers, and other devices. 18" length.  
(18" Halogen) #LULEBNC18H ..... **\$38.50**  
(18" Incandescent) #LULEBNC18 ..... **\$32.50**

**LUMIN-EZE**  
**XLR Lamp**

This Lumin-Eze gooseneck lamp features a halogen bulb and is designed for a console with 3-pin XLR light mounting inputs.  
(18" Halogen) #LULEXLR318H ..... **\$38.50**  
(18" Incandescent) #LULEXLR318 ..... **\$32.50**



**LITTLITE**  
**L-2/12**

#TEL212  
**\$54<sup>95</sup>**

Littlite L-2/12 is a flexible, low-intensity gooseneck lamp suited to console-top applications, and features a permanently-attached gooseneck with a low-intensity incandescent bulb.

**GARFIELD**  
**Tape Roll Bungee**

#GATRB  
**\$12<sup>95</sup>**

The Garfield Belt Tape Roll Bungee with a carabiner provides a convenient way to transport assorted tape products, cables, and cords.



**LIGHTWARE**  
**A2020-6 Slip Cord**

#LICL6  
**\$26<sup>50</sup>**

The Lightware A2020-6 is a practical elastic slip cord great for securing and holding cables, or to mount hardware and gobos to frames or trusses.

**SE ELECTRONICS**

**Reflexion Filter**

The Reflexion Filter is a unique acoustic treatment filter/isolator for large-diaphragm microphone recording applications like vocals, essentially a six-layer curved baffle with an air barrier. It is easily positioned behind the mic using the attached variable-position stand clamp. The filter successfully minimizes direct reflections from adjacent walls and other hard surfaces, diminishing aberrant or unwanted room ambience.

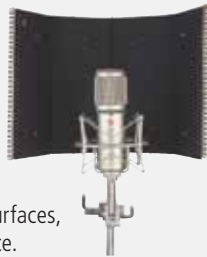

#SERF  
**\$299.00**

**SEE-IRF** instrument version #SEIRF.....**\$149.00**



**SCHULZE-BRAKEL  
Mic Flags**

High-quality foam microphone ID flags available in three different shapes and various

sizes. Available in 2 colors: Black & Blue. Add your logo using standard iron-on transfers.

**4 x 2" Triangle** foam microphone flag #SCTFR105.....**\$9.99**

**4 x 1.8" Triangle** foam microphone flag #SCTFR103.....**\$9.99**

**3.3 x 2" Round** foam microphone flag #SCRFB55.....**\$9.99**

**HEAROS**

**Music Series Ear Plugs**

Hearos Rock 'n Roll series of flex-molded hearing protection products provide up to 26dB of noise attenuation, and are washable and reusable.

#HERRIC  
**\$4.95**



**Foam Ear Plugs**

Hearos Ultimate Softness series of ear protection products, offering 32dB of noise attenuation, are available in a 20-pair, ultra-soft foam ear-plug value pack.

#HEUSS20  
**\$7.95**

**Round Mic ID Flags**

Round ID microphone flag well suited for handheld ENG microphones. Measures 2.25" black #GBMFMRB, white #GBMFMRW, blue #GBMFMRBL.....



**\$26.95**

**Square Mic ID Flags**



Square ID microphone flag designed for handheld ENG microphones. Measures 2.25"

black #GBMFMSB, white #GBMFMSW .....**\$24.95**

**RYCOTE**

**Undercovers**

Disposable mounting and windshield system for lavalier microphones. Supplied in packs, with (3) sheets of double-sided adhesive pads (10 pads per sheet, 30 pads total).

#RYUC  
**\$12.95**



**Overcovers**

Semi-disposable mounting and windshield system for lavalier microphones. Supplied in packs, with (3) sheets of double-sided adhesive pads (10 pads per sheet, 30 pads total).

#RYOC  
**\$16.95**

**Triangle Mic ID Flags**

Triangle ID microphone flag for handheld ENG microphones. Measures 2.25 x 3.75" black #GBMFMTB, white #GBMFMTW, blue #GBMFMTBL.....



**\$29.95**



**GARFIELD**

**Headphone Softie**

Made from soft Rayon Chenille fabric, these softies slip over existing headphone earpieces easily, providing a new comfort for anyone who wears headphones for extended periods. black #GAHSBK, blue #GAHSBLU, red #GAHSRED, green #GAHSG, gold #GAHSGLD

#GAHSBK  
**\$15.95**

**MATTHEWS**

**Sound Blanket**

The Matthews Sound Blankets can be used to hang in a vocal isolation booth or small room for added sound insulation.

**With Grommets** #MASBG.....**\$49.95**

**Without Grommets** #MASBQ.....**\$42.50**



**DATRAX/BRYCO  
DP Portable DAT Case**

Heavy-duty ballistic Cordura carrying cases with rigid plastic inserts that protect valuable data when traveling.

**16 tapes** #DADP16.....**\$29.95**

**8 tapes** #DADP8.....**\$17.95**

**DATRAX/BRYCO**

**DRP Wall Mount**

DAT Case

High-impact molded plastic DAT cases conveniently wall mounted, horizontally or vertically.

40 tapes #DADRP40.....**\$16.95** 8 tapes #DADRP8.....**\$4.95**



**CDP60 Wall Mount**

CD Storage Case

High-impact molded plastic case, wall mountable, stackable, and holds up to 60 CD's.

#DACDP60  
**\$19.95**



**KORG**  
**Beatlab**

BeatLab makes it easy to practice and perfect a variety of rhythms and styles, and is designed with an extra-loud volume for all you drummers out there.

#KOBTL1  
**\$99<sup>99</sup>**



**KORG**  
**MM-2**

The MM-2 is a personal metronome that fits on your ear, allowing you to play to a beat that only you can hear.

#KOMM2  
**\$24<sup>99</sup>**

**KORG**  
**KDM-2**

Korg's original, cylindrical speaker provides a powerful sound and the 19 onboard beat patterns like son clave and rumba add variety to your practice palette.

#KOKDM2  
**\$59<sup>95</sup>**



**YAMAHA**  
**QT1**

The QT1 features a volume control to adjust for louder music and two different "beat" sounds to make for a more pleasant practice session.

#YAQT1  
**\$39<sup>95</sup>**

**Yamaha QT1B** black/purple #YAQT1B.....**\$39.95**  
**Yamaha QT1BR** mahogany #YAQT1BR.....**\$39.95**

**ROLAND**  
**DB-90**

Roland's most advanced metronome helps make practice sessions less mundane with human voice-counting, MIDI input, and onboard Rhythm Coach.

#RODB90  
**\$159<sup>00</sup>**



**ROLAND**  
**DB-60**

The DB-60 metronome allows you to create rhythms that match the feel and style of your music, and has the ability to handle time signatures of up to 17 beats per measure.

#RODB60  
**\$69<sup>00</sup>**

**ROLAND**  
**DB-30**

This pocket-sized metronome lets you choose from a menu of nine rhythm types and 24 beat variations, including combinations of odd time signatures and clave patterns for practicing Latin rhythms.

#RODB30  
**\$39<sup>00</sup>**



**WHIRLWIND**  
**WT-1000**

This tuner is remarkably sensitive and features auto modes for chromatic, guitar, bass, and violin as well as manual tuning capability.

#WHWT1000  
**\$14<sup>95</sup>**



**KORG**  
**TM-40**

A great lesson and practice tool, the TM-40 offers both tuner and metronome functions simultaneously or independently.

#KOTM40  
**\$32<sup>99</sup>**



**KORG**  
**DT7**

The DT7 features a built-in mic, and is the first guitar and bass tuner to feature the Buzz Feiten Tuning system.

#KODT7  
**\$89<sup>00</sup>**

**KORG**  
**DTR-1000**

This rack-mount chromatic tuner automatically detects note name and accurate pitch while being clearly visible across a stage or studio.

#KODTR1000  
**\$179<sup>00</sup>**



**Korg DTR-2000** deluxe version with rack light and built-in mic #KODTR2000.....**\$259.00**

**BEHRINGER**  
**BTR2000**

This multi-functional rack-mount tuner not only lights your rack but features a built-in metronome with audible and visual beat indicator.

#BEBTR2000  
**\$59<sup>99</sup>**



**ROLAND**  
**TU-80**

The TU-80 is an affordable and reliable LCD tuner with a handy, built-in metronome. The ultra-thin design fits easily into your pocket or gigbag.

#ROTU80  
**\$29<sup>00</sup>**



**ROLAND**  
**TU-15**

This compact tuner features an Accu-Pitch function that verifies intonation by sounding a note when the correct tuning is reached.

#ROTU15  
**\$79<sup>95</sup>**



**ROLAND**  
**TU-2**

The TU-2 Chromatic Tuner incorporates TU series tuner technology into a rugged, ultra-convenient stompbox design.

#ROTU2  
**\$99<sup>00</sup>**



**ROLAND**  
**TU-12**

The TU-12 is the worldwide standard in chromatic tuners for acoustic and electric guitar and bass.

#ROTU12  
**\$81<sup>95</sup>**

**Roland TU-12H** features wide tuning range #ROTU12H.....**\$81.95**

### Gator Rack Cases

Gator offers a complete selection of rack-mount bags and cases that are perfect for local or worldwide travel. These cases are made of lightweight polyethylene, feature heavy-duty twist latches and replaceable zinc plated steel rack rails. G-tour cases are constructed of 9mm plywood with a PVC exterior.

#### Rack Bags

<b>Gator GRB-2U</b> 2-space rack bag #GAGRB2U.....	<b>\$59.99</b>
<b>Gator GRBW-2U</b> 2-space rack bag with wheels #GAGRBW2U.....	<b>\$89.99</b>
<b>Gator GRB-3U</b> 3-space rack bag #GAGRB3U.....	<b>\$64.99</b>
<b>Gator GRBW-3U</b> 3-space rack bag with wheels #GAGRBW3U.....	<b>\$99.99</b>
<b>Gator GRB-4U</b> 4-space rack bag #GAGRB4U.....	<b>\$69.99</b>
<b>Gator GRBW-4U</b> 4-space rack bag with wheels #GAGRBW4U.....	<b>\$109.99</b>



#### Shallow Rack Cases

<b>Gator GR-3S</b> 3-space shallow rack case #GAGR3S.....	<b>\$89.99</b>
<b>Gator GR-4S</b> 4-space shallow rack case #GAGR4S.....	<b>\$99.99</b>
<b>Gator GR-6S</b> 6-space shallow rack case #GAGR6S.....	<b>\$109.99</b>

#### Standard Rack Cases

<b>Gator GR-2L</b> 2-space deluxe rack case #GAGR2L.....	<b>\$99.99</b>
<b>Gator GR-4L</b> 4-space deluxe rack case #GAGR4L.....	<b>\$109.99</b>
<b>Gator GRR-4L</b> 4-space deluxe rack case with wheels #GAGRR4L.....	<b>\$149.99</b>
<b>Gator GR-6L</b> 6-space deluxe rack case #GAGR6L.....	<b>\$124.99</b>
<b>Gator GRR-6L</b> 6-space deluxe rack case with wheels #GAGRR6L.....	<b>\$149.99</b>
<b>Gator GR-8L</b> 8-space deluxe rack case #GAGR8L.....	<b>\$144.99</b>
<b>Gator GRR-8L</b> 8-space deluxe rack case with wheels #GAGRR8L.....	<b>\$169.99</b>
<b>Gator GR-10L</b> 10space deluxe rack case #GAGR10L.....	<b>\$164.99</b>
<b>Gator GRR-10L</b> 10space deluxe rack case with wheels #GAGRR10L.....	<b>\$189.99</b>
<b>Gator GR-12L</b> 12-space deluxe rack case #GAGR12L.....	<b>\$184.99</b>



#### Shock Rack Cases

<b>Gator G-SHOCK-4L</b> 4-space shock rack case #GAGSHOCK4L.....	<b>\$249.99</b>
<b>Gator G-SHOCK-8L</b> 8-space shock rack case #GAGSHOCK8L.....	<b>\$299.99</b>
<b>Gator G-SHOCK-12L</b> 4-space shock rack case #GAGSHOCK12L.....	<b>\$349.99</b>
<b>Gator G-SHOCK-16L</b> 4-space shock rack case #GAGSHOCK16L.....	<b>\$399.99</b>

#### G-Tour Rack Cases

<b>Gator G-TOUR-2U</b> 2-space tour-style rack case #GAGTOUR2U.....	<b>\$144.99</b>
<b>Gator G-TOUR-4U</b> 4-space tour-style rack case #GAGTOUR4U.....	<b>\$179.99</b>
<b>Gator G-TOUR-4UW</b> 4-space tour-style rack case with wheels #GAGTOUR4UW.....	<b>\$219.99</b>
<b>Gator G-TOUR-6U</b> 6-space tour-style rack case #GAGTOUR6U.....	<b>\$209.99</b>
<b>Gator G-TOUR-8U</b> 8-space tour-style rack case #GAGTOUR8U.....	<b>\$229.99</b>
<b>Gator G-TOUR-12U</b> 12-space tour-style rack case #GAGTOUR12U.....	<b>\$299.99</b>



#### G-Tour Shock Racks

<b>Gator G-TOUR SHK-4</b> 4-space tour-style shock rack case #GAGTRRSHK4.....	<b>\$309.99</b>
<b>Gator G-TOUR SHK-8-CAST</b> 8-space tour-style shock rack case #GAGTRRSHK8C.....	<b>\$479.99</b>
<b>Gator G-TOUR SHK-12-CAST</b> 12-space tour-style shock rack case #GAGTRRSHK12.....	<b>\$529.95</b>

**APPLE**

**iMac**

The slim, all-in-one iMac sets new standards for speed, elegance and simplicity. All components are tightly packaged into a sleek, anodized aluminum frame. Advanced dual-core Intel processors deliver speeds of up to 2.8GHz. Widescreen 20" and 24" glossy displays enhance photos, movies and games with rich, vivid color. Built-in iSight camera allows you to video chat with family and friends. Hardware coupled with iLife '08 software presents unlimited possibilities for creating photobooks, editing videos, building blogs, composing songs, and much more.



**20"** All 20" iMacs come with a 2.4GHz Intel Core 2 Duo, 8x double-layer SuperDrive, 20" glossy widescreen display, ATI Radeon HD 2600 PRO graphics w/256MB, AirPort Extreme, Bluetooth 2.0 + EDR, iLife '08, Mac OS X 10.5 Leopard, Wireless Mighty Mouse and keyboard

- 2.4GHz** Intel Core 2 Duo, 1GB memory, 320GB 7200 rpm SATA hard drive, ATI Radeon HD 2600 PRO graphics #APIM24S20 ..... **\$1494.00**
- 2.4GHz** Intel Core 2 Duo, 2GB memory, 500GB/7200 rpm SATA hard driv, ATI Radeon HD 2600 PRO graphics #APIM24S20Q..... **\$1769.00**
- 2.4GHz** Intel Core 2 Duo, 2GB memory, 750GB/7200 rpm SATA hard drive, ATI Radeon HD 2600 PRO graphics #APIM24S20ZJ..... **\$1919.00**

**24"** All 24" iMacs come with an 8x double-layer SuperDrive, 24" glossy widescreen display, ATI Radeon HD 2600 PRO graphics w/256MB, Airport Extreme, Bluetooth 2.0 + EDR, iLife '08, Mac OS X 10.5 Leopard, Wireless Mighty Mouse and keyboard

- 2.4GHz** Intel Core 2 Duo, 1GB memory, 320GB/7200 rpm SATA hard drive #APIM24S24..... **\$1798.95**
- 2.4GHz** Intel Core 2 Duo, 2GB memory, 500GB/7200 rpm SATA hard drive #APIM24S24Q..... **\$1999.95**
- 2.4GHz** Intel Core 2 Duo, 2GB memory, 750GB/7200 rpm SATA hard drive #APIM24S24Z..... **\$2219.00**
- 2.8GHz** Intel Core 2 Extreme, 2GB memory, 500GB/7200 rpm SATA hard drive #APIM28S24..... **\$2248.95**
- 2.8GHz** Intel Core 2 Duo, 4GB memory, 1TB/7200 rpm SATA hard drive #APIM28S24Q..... **\$2999.95**



**APPLE**

**Mac Pro**

Configure the Mac Pro system of your dreams. Blast through processor-intensive applications with 4- or 8-core Intel Xeon powered systems running as fast as 3.2 GHz. The Mac Pro features four PCI Express slots and can accommodate up to four hard drives, 4TB of storage, 32GB of memory, two Double-Layer SuperDrives and plenty of other options. Create your own personal dream machine with millions of possible build-to-order configurations.

**2.8GHz** All 2.8GHz Mac Pros come with 2.8GHz Quad Core Intel Xeon processors, 7200 rpm SATA hard drives, 16x dual-layer SuperDrives, Bluetooth 2.0 + EDR, Airport Extreme, Mac OS X 10.5 Leopard, Mighty Mouse and keyboard

- One** 2.8GHz Quad Core, 2GB memory, 320GB HD, ATI Radeon HD 2600 XT w/256MB #APMP128..... **\$2348.95**
- Two** 2.8GHz Quad Cores, 2GB memory, 500GB HD, nVidia GeForce 8800 GT w/512MB #APMP228..... **\$3148.50**
- Two** 2.8GHz Quad Cores, 2GB memory, 320GB HD, ATI Radeon HD 2600 XT w/256MB #APMP228A..... **\$2749.95**
- Two** 2.8GHz Quad Cores, 2GB memory, 500GB HD, ATI Radeon HD 2600 XT w/256MB #APMP228B..... **\$2949.00**

**3GHz** All 3GHz Mac Pros come with 3GHz Quad Core Intel Xeon processors, 7200 rpm SATA hard drives, 16x dual-layer SuperDrives, Bluetooth 2.0 + EDR, Airport Extreme, Mac OS X 10.5 Leopard, Mighty Mouse and keyboard

- Two** 3GHz Quad Cores, 2GB memory, 500GB HD, ATI Radeon HD 2600 XT w/256MB #APMP230..... **\$3748.50**
- Two** 3GHz Quad Cores, 4GB memory, 750GB HD, Two SuperDrives, ATI Radeon HD 2600 XT w/256MB #APMP230B..... **\$4498.50**
- Two** 3GHz Quad Cores, 2GB memory, 500GB HD, nVidia GeForce 8800 GT w/512MB #APMP230C..... **\$3949.00**
- Two** 3GHz Quad Cores, 4GB memory, 320GB HD, ATI Radeon HD 2600 XT w/256MB #APMP230D..... **\$4148.50**
- Two** 3GHz Quad Cores, 4GB memory, 500GB HD, nVidia GeForce 8800 GT w/512MB #APMP230E..... **\$4449.00**

**3.2GHz** All 3.2GHz Mac Pros come with 3.2GHz Quad Core Intel Xeon processors, 7200 rpm SATA hard drives, 16x dual-layer SuperDrives, Bluetooth 2.0 + EDR, Airport Extreme, Mac OS X 10.5 Leopard, Mighty Mouse and keyboard

- Two** 3.2GHz Quad Cores, 4GB memory, 500GB HD, nVidia GeForce 8800 GT w/512MB #APMP232..... **\$5248.50**
- Two** 3.2GHz Quad Cores, 4GB memory, 500GB HD, nVidia Quadra FX 5600 w/1.5GB #APMP232A..... **\$7897.95**
- Two** 3.2GHz Quad Cores, 4GB memory, 500GB HD, ATI Radeon HD 2600 XT w/256MB #APMP232B..... **\$5048.50**



**APPLE**

**MacBook Pro**

The MacBook Pro is designed for creative professionals on-the-go. Loaded with new and powerful Intel Core 2 Duo mobile processors, the MacBook Pro now supports up to 4GB of memory. The nVidia GeForce8600M GT card delivers tremendous processing power for graphics-intensive applications. Built-in iSight webcams, 802.11n wireless technology, and an Apple Remote are just a few of the features that make the MacBook Pro a truly mobile powerhouse.



**15"** All 15" MacBook Pros come with Intel Core 2 Duo processors, a SATA hard drive, a 15" widescreen display (1440x900), an 8x SuperDrive DVD burner, an iSight webcam, Bluetooth 2.0 + EDR, 802.11n AirPort Extreme and Mac OS 10.5 Leopard

<b>2.4GHz</b> processor, 2GB memory, 200GB/7200rpm HD, nVidia GeForce 8600M GT w/256MB	#APMBP24S15NG (glossy).....	<b>\$2098.95</b>
<b>2.4GHz</b> processor, 2GB memory, 200GB/7200rpm HD, nVidia GeForce 8600M GT w/256MB	#APMBP24S15NZ.....	<b>\$2099.00</b>
<b>2.4GHz</b> processor, 4GB memory, 200GB/7200rpm HD, nVidia GeForce 8600M GT w/256MB	#APMBP24S15NX.....	<b>\$2499.00</b>
<b>2.5GHz</b> processor, 2GB memory, 250GB/5400rpm HD, nVidia GeForce 8600M GT w/512MB	#APMBP25S15G (glossy).....	<b>\$2499.00</b>
<b>2.5GHz</b> processor, 2GB memory, 200GB/7200rpm HD, nVidia GeForce 8600M GT w/512MB	#APMBP25S15Z.....	<b>\$2549.00</b>
<b>2.5GHz</b> processor, 4GB memory, 200GB/7200rpm HD, nVidia GeForce 8600M GT w/512MB	#APMBP25S15X.....	<b>\$2994.00</b>
<b>2.6GHz</b> processor, 2GB memory, 250GB/5400rpm HD, nVidia GeForce 8600M GT w/512MB	#APMBP26S15I.....	<b>\$2749.00</b>
<b>2.6GHz</b> processor, 2GB memory, 250GB/5400rpm HD, nVidia GeForce 8600M GT w/512MB	#APMBP26S15J (glossy).....	<b>\$2749.00</b>
<b>2.6GHz</b> processor, 4GB memory, 200GB/7200rpm HD, nVidia GeForce 8600M GT w/512MB	#APMBP26S15K.....	<b>\$3199.00</b>
<b>2.6GHz</b> processor, 2GB memory, 200GB/7200rpm HD, nVidia GeForce 8600M GT w/512MB	#APMBP26S15L.....	<b>\$2799.00</b>

**17"** All 17" MacBook Pros come with a 17" hi-res widescreen display (1680x1050), Intel Core 2 Duo processors, a SATA hard drive, an 8X SuperDrive DVD burner, Bluetooth 2.0 + EDR, 802.11n AirPort Extreme and Mac OS 10.5 Leopard

<b>2.5GHz</b> processor, 2GB memory, 250GB/5400rpm HD, nVidia GeForce 8600M GT w/512MB	#APMBP25S17G (glossy).....	<b>\$2799.00</b>
<b>2.5GHz</b> processor, 2GB memory, 200GB/7200rpm HD, nVidia GeForce 8600M GT w/512MB	#APMBP25S17A.....	<b>\$2949.00</b>
<b>2.5GHz</b> processor, 4GB memory, 250GB/5400rpm HD, nVidia GeForce 8600M GT w/512MB	#APMBP25S17B.....	<b>\$3349.00</b>
<b>2.6GHz</b> processor, 4GB memory, 200GB/7200rpm HD, nVidia GeForce 8600M GT w/512MB	#APMBP26S17H.....	<b>\$3599.00</b>
<b>2.6GHz</b> processor, 2GB memory, 200GB/7200rpm HD, nVidia GeForce 8600M GT w/512MB	#APMBP26S17HQ.....	<b>\$3179.00</b>



**APPLE**  
**MacBook**

The latest MacBooks are designed for users that insist on MacBook quality and performance in a package that's both affordable and light in weight. Powered by Intel Core 2 Duo processors running at speeds up to 2.4GHz, the new MacBooks are faster than ever. In bright white or sleek black, the MacBook supports up to 4GB of memory and up to 250GB of storage. You'll be able to run any application and have storage space to spare for your ever growing media collection. The 13.3-inch glossy widescreen display produces crisp, vivid images, and is also ideal for multimedia and entertainment applications.

All MacBooks come with a 13.3" widescreen display (1280x800), Intel GMA X3100 graphics, Bluetooth 2.0 + EDR, 802.11n AirPort Extreme Wi-Fi and Mac OS 10.5 Leopard

<b>2.1GHz</b> processor, 2GB memory, 160GB/5400rpm HD, CD-RW/DVD-ROM combo	#APMB21S13WZ.....	<b>\$1249.00</b>
<b>2.4GHz</b> processor, 2GB memory, 250GB/5400rpm HD, 8x SuperDrive	#APMB24S13WZ.....	<b>\$1399.00</b>
<b>2.4GHz</b> processor, 4GB memory, 250GB/5400rpm HD, 8x SuperDrive	#APMB24S13WX.....	<b>\$1799.00</b>
<b>2.4GHz</b> processor, 4GB memory, 250GB/5400rpm HD, 8x SuperDrive	#APMB24S13BX (black).....	<b>\$1899.00</b>

**HEWLETT PACKARD****HP M9280F Pavilion Elite**

The HP Pavilion Elite enhanced features and technology puts everything you need where you want it. Go wireless and clutter free with wireless keyboard, mouse, and remote control. The Pavilion Elite PC also features a built in wireless antenna for Wireless LAN 802.11a/b/g/n networking. Press the HP Easy Backup button and instantly back up your files.

- 2.5GHz Intel Core 2 Quad Processor Q9300
- Go Wireless with 802.11 b/g/n
- 1000GB Storage with Dual 500GB Hard Drives Store
- 4GB PC2-6400 DDR2 SDRAM Memory
- Blu Ray/ HD DVD player and SuperMulti DVD Burner with LightScribe Technology-NTSC TV tuner and Over the Air ATSC High Definition TV Tuner
- Genuine Windows Vista Home Premium 64 bit Edition with Service Pack



#HEM9280F  
**\$1799<sup>99</sup>**

**HEWLETT PACKARD****Pavilion DV9830US****17" Widescreen Entertainment Laptop**

The HP Pavilion DV9830US is a large laptop, with high-performance processing power and entertainment features to rival most desktops. This model has premium features including a Blu-Ray ROM, an ExpressCard TV tuner, a built-in webcam and 64-bit Windows Vista Home Premium. This laptop features the dual-core 1.83GHz Intel Core 2 Duo T5550 processor.

- Intel Core 2 Duo T5550
- 320GB hard drive
- Built-in wireless 802.11agn • 4GB of DDR2 RAM
- Plays Blu-Ray, burns DVDs
- ExpressCard TV tuner



#HEDV9830US  
**\$1399<sup>95</sup>**

**SONY****VAIO AR Series VGN-AR790U/B****Notebook Computer**

The VAIO AR Series 790U/B notebook is a multimedia powerhouse with DVR capabilities and a 17" widescreen display with XBRITE-HiColor LCD technology. Featuring an Intel Core 2 Duo T9300 processor, a 400GB hard drive and 4GB memory, the AR790U/B notebook is a super-powerful notebook. Watch and record in stunning



Blu-ray Disc format and even watch, record and manage cable TV content.

- 2.5GHz Intel Core 2 Duo Processor T9300 CPU
- 4GB (2x2GB) RAM • 400GB (2x200GB RAID 0) 5400rpm Hard Drive
- Blu-ray Burner • nVIDIA GeForce 8600M GT Graphics
- External ATI TV Tuner • 17" Widescreen Display
- Bluetooth, 802.11a/b/g/n Wi-Fi • Windows Vista Ultimate • 8.4 lbs

#SOVGNAR790UB  
**\$3299<sup>50</sup>**

**TOSHIBA****Satellite X205-SLI6****17" Notebook**

The Satellite X205-SLI6 is action at your fingertips in one sleek designed notebook with astonishing views from the 17-inch diagonal TruBrite widescreen display. One touch launch of the Dual Mode Pad and you face off in full throttle mode with Intel Centrino Duo processor technology.



- 2.5GHz Intel Core 2 Duo Processor T9300
- Mobile Intel PM965 Express Chipset-Configured
- 3GB PC2-5300 DDR2 SDRAM
- 400GB Using Two 200GB 7200 RPM Serial ATA Hard Disk Drives
- 17.0 Inch Diagonal Widescreen TruBrite TFT LCD Display
- Microphone Built Into LCD bezel
- Bluetooth Version 2.0 plus EDR

#TOX205SLI6  
**\$2389<sup>95</sup>**

**LENOVO****Y7101****17" Widescreen Notebook**

The Lenovo IdeaPad Y7101 notebook offers more than just innovative features. It has a fresh new look, and special design features that set them apart from the competition. With 2GB memory standard and advanced Intel Dual-Core processors, the Lenovo IdeaPad Y710 17" widescreen notebook will quickly become your personal mobile entertainment center.



- 17" display with frameless screen
- VeriFace face recognition security
- Dolby Home Theater audio • Optional secondary hard drive
- 2GB RAM • 250GB hard drive • DVD Burner
- ATI Radeon HD2600 • Microsoft Vista

#LEY7101  
**\$1199<sup>95</sup>**

**TOSHIBA****Tecra A9 9021V****Notebook Computer**

The Tecra A9 Series provides exceptional performance, durability and security by blending Intel's Centrino Pro processor technology with Toshiba's 3rd generation EasyGuard technology<sup>2</sup> in an affordable desktop replacement notebook for professionals and students.

- 2.5GHz Intel Core 2 Duo Processor T9300
- 2GB (2x1GB) RAM
- 250GB 5400rpm SATA Hard Drive
- SuperMulti DVD Burner
- nVIDIA Quadro NVS 130M Graphics
- 15.4" Widescreen Display • Bluetooth 2.0+EDR
- 802.11a/b/g/n Wi-Fi • Windows Vista Business • 6.35 lbs



#TOA9S9021V  
**\$1698<sup>95</sup>**

## RAIN RECORDING

### Element Tower 5

#RAET5  
**\$2199<sup>95</sup>**

Fast and quiet, the Element T5 features a 2.33GHz Intel Pentium Core 2 Duo processor with 2GB of RAM and dual 250GB SATA II HDD's. Its audio drive is dedicated to streaming audio and is capable of recording your audio tracks while running numerous instances of plug-in effects and virtual instruments seamlessly. Extensive expandability and a powerful software bundle combine the tools to begin creating immediately with the room to grow.



- 2.33GHz Intel Pentium Core 2 Duo, 2GB DDR-2 RAM (800MHz Dual Channel - Matched Pair)
- Dual 250GB SATAII HDD's 16MB buffer
- (7) USB 2.0 ports (4 rear/3 front), (5) FireWire ports
- Dual Layer DVD±RW/CD-RW Combo Optical Drive
- NERO Express CD/DVD Creation Software Acronis True Image Recovery Software
- Windows XP Professional or Vista Ultimate

## RAIN RECORDING

### Nimbus-VM1

#### Digital Audio/Video Workstation

Nimbus is designed for advanced audio and video content creation. Intel's Core 2 Quad 2.4GHz processor is at the center of a system architecture engineered to provide you with industry-leading A/V editing capabilities. For video, there is no more powerful graphics system than the included nVIDIA Quadro FX1500, a ground-breaking GPU delivering 42.Gbps of data transfer with 32-bit floating point precision.

- 4GB DDR-2 800Mhz RAM
- 500GB Drive
- 1TB RAID-0 Audio Drive
- Dual Layer DVD+RW/CD-RW
- nVIDIA Quadro FX1500
- Windows XP Pro or Vista Ultimate
- RainCare Precision Support
- 7 USB 2.0 / 5 Firewire



#RANVM1  
**\$3199<sup>95</sup>**

## RAIN RECORDING

### Solstice 01

#### Digital Audio Workstation

Using the latest AMD Athlon 64 X2 Dual Core engine, Solstice brings you superior processing power, incredible efficiency, and a breathtaking visual experience without the need for a separate graphics card. Turn on Solstice and see the cool, blue light peer through the sleek all aluminum chassis as you push endless tracks, plug-ins, and virtual instruments with virtually silent Quiet Cool engineering.



- 2GB DDR-2 RAM
- 250GB HDD
- 250GB Audio Drive
- Dual Layer DVD+RW/CD-RW
- ATI Radeon x1250
- Windows XP Pro or Vista Ultimate
- RainCare Precision Support
- 7 USB 2.0 / 3 Firewire

#RAS01  
**\$1599<sup>95</sup>**

## MUSICXPC

### Professional C5

The Professional C5 is a Windows-based PC that features an Intel Core 2 Duo CPU and more than a half-terabyte of hard-disk storage — all in the space of 3 hard drive cases. The Professional C5 is designed for professional musicians who want the computer at the heart of their digital studio to be flawless, supremely powerful, quiet, and robust. The Professional C5 is all those things and then some.



- 2.13GHz CPU
- 1GB RAM
- DVD±RW/CD-RW, 16X
- 8x USB 2.0
- FireWire 2 [front: 1 | 4-pin] [rear: 1 | 6-pin]
- PCI 2.3 slots- 1
- PCI-E x16 slots-1
- Graphics Intel GMA950 256-bit 3D Engine
- SATA250 7200rpm 120GB HD
- SATA320 7200rpm 200GB HD
- Microsoft Windows XP

#MUPC5  
**\$1899<sup>00</sup>**

## RAIN RECORDING

### LiveBook L6

LiveBook is built on Intel's Core 2 Duo technology and rigorously field tested to provide stability and consistency without sacrificing performance or features. And with new additions like a built-in Webcam and Bluetooth, and the integrated Azalia Audio Chip, LiveBook gives you everything you need to record, play back, and share music without overheating or audio drop-outs.

- 1.8 GHz Intel Core 2 Duo
- 2GB DDR-2 RAM
- 100GB SATA 7200RPM Hard Drive
- CD-RW / DVD-RW +/- Dual Layer
- 15.4-inch Widescreen
- Windows XP Pro or Vista Ultimate
- RainCare Precision Support



#RALBL6  
**\$1999<sup>95</sup>**

## MUSICXPC

### Professional M4

The Professional M4 features an Intel Core 2 Duo 1.83GHz CPU, a 100GB 5400 rpm HDD, 1GB of DDR2 RAM [expandable to 2GB], a 15.4-inch WXGA wide angle, and non-glare screen with superior off-axis performance. The recovery utility stores the system factory settings outside of Windows XP in a host-protected area of the hard drive in case of re-formatting. Gigabit LAN improves workflow and plays projects stored on other computers via Ethernet; built in 8X DVD+/-RW burner.

- 15.4-inch WXGA TFT Active Matrix Color (1280 x 800)
- Intel Graphics Media Accelerator 950 with DirectX 9 acceleration
- SATA 100GB, 5400 RPM
- 4-in-1 card reader
- 3 USB 2.0 ports, VGA monitor display port
- 3 Firewire, Microphone-in



#MUPM4  
**\$1899<sup>00</sup>**



**WESTERN DIGITAL****My Book Studio Edition**

Speed is what you need for audio editing, big design projects, or managing photo shoots and that's what this drive delivers with FireWire 800 and eSATA connectivity. With our automatic backup capability your creative masterpieces will be backed up the minute you save them. You can now back up important projects to multiple destinations including files servers, portable drives and My Book. Synchronize project files to keep them current and secure. Set it and forget it; every time you save a change it's automatically backed up.

- High capacity • Small footprint design • Quad Interface
- Formatted for Macintosh • Extra-fast performance

<b>1TB</b> #WEWDH1Q1000 .....	<b>\$269.95</b>
<b>750GB</b> #WEWDH1Q7500N.....	<b>\$219.95</b>
<b>500GB</b> #WEWDH1Q5000N.....	<b>\$156.95</b>

**WESTERN DIGITAL****My Book Studio Edition II**

WD introduced its My Book Studio Edition II high-performance dual-drive storage systems which are designed to seamlessly work with Mac computers and provide an ideal blend of power savings and high performance.

- Extra- fast performance with four interfaces (FireWire 400/800, eSATA, USB 2.0);
- Factory-shipped in RAID 0 (Striped) configuration [RAID 1 (Mirrored) • Eco-friendly operation • Designed without a fan to run quietly; • 5-year limited warranty; • Automatic and continuous backup software;

<b>1TB</b> #WEWDH2Q1000 .....	<b>\$299.95</b>
<b>750GB</b> #WEWDH2Q15000N.....	<b>\$219.95</b>
<b>500GB</b> #WEWDH1Q20000N.....	<b>\$156.95</b>

**LACIE  
D2 QUADRA**

The high capacity d2 Quadra Hard Drive from LaCie features a large 32MB cache, a 7200 rpm rotation speed, and sustained transfer speeds of up to 90Mbps. With a quad-interface that allows it to be connected via eSATA, FireWire- 400, FireWire-800 or USB 2.0, storing data is simple. Its ultra quiet functioning and elegant design allows it to incorporate effortlessly into any home or office.

- Quiet Operation
- Includes EMC Retrospect Express backup software for PC and Mac
- The drive is hot-swappable and plug-and-play

<b>1TB</b> #LAD2QHDI1TB .....	<b>\$349.95</b>
<b>750GB</b> #LAD2QHDI750 .....	<b>\$229.95</b>
<b>500GB</b> #LAD2QHDI500 .....	<b>\$174.95</b>

**LACIE****2big Network Hard Drive  
with Gigabit Ethernet**

The 2big Network can act as a file-sharing server, a backup server or an FTP server. Easily share important files and make them accessible from your network via FTP or any web browser. With this affordable 2-disk RAID solution with Ethernet interface, get maximum storage capacity in BIG mode or maximum security in RAID 1.

- Shared Office Storage • Easy Setup & Access • RAID Flexibility
- Superior Design • 7200 rpm

<b>1TB</b> #LA2BN1TB .....	<b>\$319.95</b>
<b>750GB</b> #LA2BN1.5TB .....	<b>\$499.95</b>
<b>500GB</b> #LA2BN2TB .....	<b>\$748.95</b>

**G-TECH****G-Drive Q****Quad Interface External Hard Drive**

G-DRIVE Q storage solutions offer the ultimate in flexibility by providing users with FireWire 400, FireWire 800, USB 2.0 and eSATA ports all in a single unit. G-DRIVE Q is the perfect high-performance solution for storage intensive applications including audio/video editing, digital photography MP3 libraries and high-speed data back up.

- Fan-less design with unique silent cooling technology
- Storage capacities up to 1000 GB
- Utilizes the next-gen 924 chipset from Oxford Semiconductor
- High-performance 7200 RPM SATA II drives w/up to 32MB cache
- Standard 3-Year factory warranty
- Driver-free operation with Mac OS X and Windows 2000/XP

<b>1TB</b> #GTGDQ1 .....	<b>\$539.95</b>
<b>750GB</b> #GTGDQ750.....	<b>\$418.95</b>
<b>500GB</b> #GTGDQ500 .....	<b>\$264.95</b>

**G-TECH****G-Raid2 2-Disk FireWire-400, FireWire-800  
and USB 2.0 External Hard Drive Array**

The G-Raid2 2-Disk Triple Interface external hard drive array from G-Technology is a high-capacity external RAID that features two 7200 rpm drives striped together in a hardware RAID 0 configuration and an interface that allows it to be connected via FireWire-800 FireWire-400 or USB 2.0. The drive is housed in a durable titanium external casing that features a small and quiet fan for cooling.

- Multiple Stream Playback
- SATA II Drives
- Triple Interface
- Quiet Operation

<b>1TB</b> #GTGR22.....	<b>\$999.95</b>
<b>750GB</b> #GTGR21500 .....	<b>\$799.95</b>
<b>500GB</b> #GTGR21 .....	<b>\$489.95</b>



**GLYPH  
GT 050Q**



Glyph-Technologies offers a number of different desktop closures that can connect to your computer via the FireWire-800, FireWire-400, USB 2.0, or eSATA interface. The drive enclosure is designed for use in professional audio applications. The enclosure is constructed from stainless steel and features tri-laminate sound damping to help reduce noise. This makes the drive an ideal solution for storage in audio and video production environments.

- Glyph exclusively uses high-quality Seagate drives
- Features a large 8MB data buffer
- 7200 rpm rotation speed • 8 ms seek time

#GLGT050Q750.....	<b>\$629.00</b>	#GLGT050Q250.....	<b>\$279.00</b>
#GLGT050Q500.....	<b>\$399.00</b>	#GLGT050Q160.....	<b>\$249.00</b>

**GLYPH  
GT 050**



Glyph's fixed-mount tabletop, the GT 050, is designed for the grueling daily use of audio and video production environments. Rugged and portable, the GT 050 is constructed with a durable stainless steel and tri-laminate sound-dampening internal frame. The item is available with either FireWire or SCSI interfaces or a variety of large-capacity drives to provide smooth capturing and editing of audio and video.

- Rotational speed: 7,200 RPM
- Interface connectivity: IEEE 1394a (FireWire)
- Bridging Chip: Oxford 911 • Average seek time (read): 8.2Mbps
- Buffer size (cache): 2MB

#GLGT05080.....	<b>\$199.00</b>
#GLGT050160.....	<b>\$229.00</b>
#GLGT050250.....	<b>\$239.00</b>
#GLGT050300.....	<b>\$289.95</b>

**GLYPH  
GT Key**



The GT Key 750GB Hot Swappable Drive Cartridge from Glyph-Technology is a hard drive in a hot-swappable enclosure that is compatible with the GT 051, GT 103, GT 205, and GT 308 series of enclosures. The drive can be hot-swapped from any of these

Glyph drive enclosures, allowing you to integrate it easily into your work environment. It even includes a carrying case that allows you to store and transport the drive module safely when it is not in use.

- Glyph's integrity FireWire 400 interface
- 16MB cache in 320-750GB capacities

#GLGTK160.....	<b>\$209.00</b>	#GLGTK250.....	<b>\$229.00</b>
#GLGTK500.....	<b>\$399.00</b>	#GLGTK750.....	<b>\$569.00</b>
#GLGTK1000.....	<b>\$705.00</b>		

**GLYPH  
PortaGig**



With its tiny bus-powered enclosure, it's small enough to fit into a pocket and powerful enough to support high track-count audio sessions. With FireWire 400 and USB 2.0 interfaces, PortaGig is compatible with Mac, Windows, and Linux systems supporting FireWire or USB. Designed with a fanless, light aluminum enclosure, it allows you to work easily and reliably on the road.

- Seagate drive mechanism with 8MB cache • Weighs less than 10 Ounces
- Optional power supply available • Carrying sleeve included

<b>120GB</b> #GLPG120.....	<b>\$199.00</b>
<b>160GB</b> #GLPG160.....	<b>\$289.00</b>

**GLYPH  
GT060BR**



Glyph's GT 062 is a two-drive tabletop designed for professional audio and video applications, and supports three drive modes through the use of a rear-panel selector switch. Drives are seen as one large volume, and the built-in RAID 0 controller distributes the I/O burden by reading and writing data from both drives at the same time. The back panel features four ports for multiple connectivity options — two FW800, one FW400, and one USB2.0.

- Ideal for video, content creation, sound libraries, and data backup applications
- Internal power supply, no wall wart, internal quiet fan
- Dual Seagate SATA drive mechanisms each with 8MB cache
- Sustain data rates of 80 Mbps with Mac OS X 10.4 Tiger
- Durable Stainless Steel • Rack-mountable (rack-mount kit optional)

<b>320GB</b> #GLGT0621F320.....	<b>\$386.00</b>	<b>1TB</b> #GLGT0621F100.....	<b>\$709.00</b>
<b>500GB</b> #GLGT0621F500.....	<b>\$449.00</b>	<b>1.5TB</b> #GLGT0621F150.....	<b>\$1159.00</b>
<b>800GB</b> #GLGT0621F800.....	<b>\$609.00</b>		

**GLYPH  
GT 103**



Designed for applications requiring multiple drives, the Glyph-Technologies GT103-03 1U Rack

Enclosure can be set up with any combination of fixed-mount drives. Data can easily be transferred to other GT series enclosures with the 7200 RPM GT Key by using Integrity; an advanced FireWire hot-swap interface that provides greater reliability than current hybrid ATA-to-FireWire products.

- Single-space 19" rack mount enclosure for up to three FireWire drives
- FireWire connectivity is hot pluggable and allows for 63 devices to be daisy chained
- Engineered for professional audio and video production

<b>GT103</b> #GLGT103.....	<b>\$469.00</b>
<b>GT051</b> #GLGT051.....	<b>\$129.00</b>

**ALERA TECHNOLOGIES**

**Aleratec DVD/CD RoboRacer LS Publishing System**

The DVD/CD RoboRacer LS has fewer moving parts for maximum reliability and ease of use. It is capable of multiple unattended direct to disc LightScribe labeling or unattended disc duplication. Just load it with 100 blank LightScribe discs, use your PC to select the disc image or label you desire with the powerful Aleratec Disc Publishing Suite.

- DVD Duplication • LightScribe Printing
- 100-Disc Capacity • Automatic Operation • USB 2.0



#ALDVRRLS  
**\$779<sup>95</sup>**

**ALERA TECHNOLOGIES**

**1:11 DVD/CD Super Copy Tower**

The Alera's 1:11 DVD/CD Super Copy Tower can copy 11 CD's or DVD's simultaneously on ±DVD/CD formats at blazing fast speeds. It is the ultimate choice for mass copying of media at the last minute.

- (1) master drive (11) copy drives
- 16x DVD±R/RW
- 48x CD-R/RW



#AL111DVD5CT  
**\$1899<sup>00</sup>**



**PRIMERA**  
**Bravo II CD/DVD Printer Duplicators**

Bravo II combines automatic, robotic-based CD or DVD duplication along with full-color, 4800 dpi disc printing. Available for Mac/PC.

- DVD Version** (25 DVD's) #PRB2DVD..... **\$1749.95**
- CD Version** (25 CD's) #PRB2CDWX..... **\$2194.95**



**PRIMERA**  
**Bravo SE Blu-ray Publisher**

Bravo SE is Primera's newest "all-in-one" disc-publishing system featuring Blu-ray Media disc-burning capability. It combines fast, automated robotic CD/BD/DVD duplication with full-color, 4800 dpi direct-to-disc printing all in one compact, desktop unit. Bravo SE is ideal for producing either one at a time, unique discs or jobs of up to 20 discs at a time. It includes both Windows-based PC and Mac duplication software.

- Perfect for audio/video content and press kits • 20-disc capacity
- Save time and money with fully-automated publishing • Provided with both Mac and PC software • USB 2.0 data interface

#PRBSEBR  
**\$2994<sup>50</sup>**

**RIMAGE**  
**2000i**

The 2000i DVD/CD duplicator/printer provides some of the most advanced printing and robotic technology in the industry. Users can print directly to disc easily with customized graphics for a complete, professional publishing solution.

- Reliable, professional solution for custom-graphics • FireWire
- Optimized 2-to-1 recorder-to-printer ratio



#RI2000IDVD  
**\$3449<sup>95</sup>**

**UTRONICS**  
**SmarrCopy 1:3**

This compact desktop enclosure delivers one-touch DVD and CD duplication. Featuring a 1:5 duplication, allowing you to duplicate up to 5 discs from one master simultaneously at DVD speeds of up to 16x and CD's at up to 48x speed. This one-touch system operates independently without a computer.

- A 2x20-character LCD is included to monitor status and set options. • It supports CD-R at 40x, DVD+R and DVD-R at 16x and dual-layer DVD discs at up to 8x speed.
- 128 MB Buffer Cache Memory discs on one ink cartridge



#UTSCDVDD13  
**\$549<sup>95</sup>**



**LACIE**  
**Dupli Disc**

A much faster and more cost effective solution than professional duplication, the Dupli 125 can even erase DVD-RW and CD-RW discs. As a standalone unit, it can also be used as an external 16x DVDRW drive with any PC or Mac. Compatible with most CD and DVD formats, it recognizes formats automatically for fast, hassle-free duplication.

- Includes intuitive menus • A user-friendly LCD interface
- One touch CD and DVD duplication
- Five system modes, including copy, test ,and verify options
- Features smart controller technology and five CD and DVD writers

#LADVD15  
**\$719<sup>95</sup>**

**RIMAGE**  
**Everest II**



The Everest II can deliver, at one time, up to 120 CD-R and DVD-R discs with high resolution four color graphics. These photo-realistic images can be produced on inexpensive standard media.

- Ideal for music and video-post studios
- Less than 60 second per disc printing time
- Powerful CD designer

#RIAE2  
**\$7899<sup>95</sup>**



## APPLE Cinema Displays

Feast your eyes on more than 4 million pixels in the first high-resolution 30" flat panel display designed for the personal computer. PC-compatible with a 170° viewing angle (horizontal & vertical) and 400:1 contrast ratio, these models deliver superb picture quality.

- DVI, Firewire 400 & USB 2.0
- 20" Cinema Display 1680x1050 pixels, 250 cd/m2 brightness
- 23" Cinema HD Display 1920x1200 pixels, 270 cd/m2 brightness
- 30" (29.7 viewable) Cinema HD Display 2560x1600 pixels 270 cd/m2 brightness

#APCD30  
**\$1729<sup>00</sup>**#APCD23Q  
**\$879<sup>00</sup>**#APCD20Q  
**\$589<sup>95</sup>**

Requires graphics card with dual-link DVI



## SAMSUNG XL20

**#SAXL20  
\$1639<sup>95</sup>**

**LED backlight monitors**

The Samsung XL20 uses LED as a backlight instead of fluorescent lamps, making possible a color gamut of 114%, revealing a previously unseen world of vivid colors. It provides Adobe RGB support using a calibrator which is specifically tuned

to the XL20's high performance range. Screen Size: 20.1"; Resolution: 1600 x 1200; Brightness: 250cd/m2; Contrast Ratio: 700:1

## SAMSUNG SyncMaster 226BW

**#SA226BW  
\$318<sup>95</sup>**

**22" Widescreen LCD**



The wide, 16:10 format of SAMSUNG's 226BW digital/Analog widescreen LCD monitor gives you plenty of room for all your computer applications and multiple images. The 1680 x 1050 panel featuring 3000:1 contrast ratio creates crisp, easy-to-view images and gaming graphics, without ghosting or blurring. Complete with

Microsoft® Vista® Premium certification and advanced dual interface for both analog digital video signals, the 226BW monitor is future-ready.

## HEWLETT-PACKARD LP3065

### 30" Widescreen LCD

The HP LP3065 Flat Panel Monitor offers best-in-class performance for professionals working in visualization who need the best color and highest resolution available. Experience high resolution and crisp image clarity with a high 1000:1 contrast ratio, 12 ms response time, superior scaling, and sharp 2560 x 1600 resolution; multi-task on an extra large work space with the 30-inch viewable wide aspect screen. A dual-link DVI graphics card is required for the LP3065.

#HELP3065  
**\$1339<sup>95</sup>**

## SAMSUNG SyncMaster 275T

**#SA305T  
\$1249<sup>95</sup>**

**27" Widescreen LCD**

Imagine being able to see everything that you're thinking. Every detail of your ideas will come to life when you create them on the Samsung 305T high-definition monitor. They're the perfect monitors for professionals who need fast image processing. The LCD panel coupled with a dynamic contrast ratio of 1000:1 and resolution of 2560 x 1600 provides optimal viewing settings for user's working environment. The 305T features fast 6ms gray to gray response times, for sharp, smear-free, impressive motion video.



## NEC LCD3090WQX

### 30" Widescreen LCD

The MultiSync 3090WQXi 30" Widescreen LCD Display from NEC is a high quality monitor built with video prosumers and professionals in mind. The monitor features a high 1000:1 contrast ratio, a wide 178°/178° viewing angle and a fast 12ms response time. You'll be able to connect and toggle between two video sources thanks to the monitor's dual DVI inputs. That along with the other features makes it a great choice for video editors and graphic designers alike.

#NELCD3090WQX  
**\$1889<sup>95</sup>**

## VIEWSONIC VX2835wm

**#VIVP2835  
\$679<sup>95</sup>**

**27.5" Widescreen LCD Monitor**

Let the 28" VX2835wm widescreen LCD ramp up your desktop experience with an ultra-fast 3ms response time, integrated speakers and amp. Raise the bar to lofty heights with multiple video connections, including HDMI, a 1920 x 1200 resolution spec, 800:1 contrast ratio and 500cd/m2 brightness. Snappy detail, remarkably rich colors prevail while VESA wall-mounting convenience completes the picture. The VX2835wm is perfect for the serious gamer or movie aficionado in search of unsurpassed digital entertainment diversion.

**TRENDNET****4-port USB audio KVM switch**

- Share a keyboard, mouse, speakers, and monitor between 4 computers
- (4) USB • (4) VGA monitor
- (4) 1/8" microphone • (4) 1/8" headphone/speaker

#TRTK409K  
**\$74<sup>95</sup>**#TRTK407K  
**\$73<sup>95</sup>****TRENDNET****4-port USB KVM switch**

- Share a keyboard, mouse, and monitor between 4 computers
- (4) USB • (4) VGA monitor

**LOGITECH****Cordless Trackman Wheel Mouse**

- Wheel allows fast and easy scrolling • Features digital radio technology • Patented optical technology
- No line of sight necessary between mouse and receiver
- 5-year warranty

#LOMCTW  
**\$38<sup>95</sup>**#KEK72281US  
**\$99<sup>95</sup>****KENSINGTON****Slim Blade Trackball Mouse**

The Kensington SlimBlade Trackball Mouse gives you control even when there's no room to move a mouse, then switches to mouse mode with the push of a button. Bluetooth connectivity offers up to 30 feet of range and doesn't use up a USB port.

**IOGEAR****MiniView Symphony, 4-port**

- 4-port KVM switch • USB 2 hub • Ethernet switch and audio switch
- (1) monitor connector • (4) keyboard and mouse
- (5) 10/100Mbps ethernet connectors • (4) speaker and microphone jack
- Works with Win-, Sun- and Mac-based computers

#IOKSU4PNA  
**\$219<sup>95</sup>****IOGEAR****MiniView Symphony, 2-port**

- (4) Monitor-HDB15 Male • One Monitor-HDB15 Female One Mouse-USB Type A • (1) Keyboard-USB Type A • (4) Keyboard & Mouse USB Type B

#IOKSU2PNA  
**\$164<sup>95</sup>****LOGITECH****Cordless Trackman Wheel Mouse**

- Wheel allows fast and easy scrolling • Features digital radio technology • Patented optical technology
- No line of sight necessary between mouse and receiver
- 5-year warranty

#LOMCTW  
**\$38<sup>95</sup>**#KEK72281US  
**\$99<sup>95</sup>****KENSINGTON****Slim Blade Trackball Mouse**

The Kensington SlimBlade Trackball Mouse gives you control even when there's no room to move a mouse, then switches to mouse mode with the push of a button. Bluetooth connectivity offers up to 30 feet of range and doesn't use up a USB port.

**3DCONNEXION****Space Navigator SE USB**

- Advanced 6 degrees-of-freedom optical sensor
- 2 programmable function keys • Fly through Google Earth and 100+ 3D programs • PE model includes non-commercial use license and online tech support only • Ideal for 3D designers, students, artists and enthusiasts

#3D3DX700028  
**\$94<sup>95</sup>****Space Traveler 3d Mouse**

- Compact mobile design • Durable stainless steel construction • Simultaneously pan, zoom, and rotate 3D models • 8 programmable speed keys

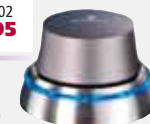
#3D132100002  
**\$199<sup>95</sup>****IOGEAR****3-port FireWire-400**

- 4-Port USB 2.0 hub • Hot-swappable • AC adapter

#IOHFW3U4  
**\$28<sup>95</sup>****IOGEAR****7-port USB 2.0 hub**

- Hot-swappable, plug-and-play
- Transfer speeds up to 480Mbps
- Mac and Win compatible • AC power adaptor

#IOHU27P  
**\$29<sup>95</sup>****KB COVERS****Pro Tools Keyboard Cover**

- Pro Tools color- and icon-coded
- Protects keyboard

#KBPTKBC  
**\$39<sup>95</sup>****KB COVERS****Pro Tools Keyboard Cover****For MacBook Pro and Aluminum Powerbook**

- Pro Tools color- and icon-coded • Protects keyboard

#KBPTPBC  
**\$29<sup>95</sup>****DIGIDESIGN****Pace iLok**

Designed for audio professionals, the iLok USB Smart Key is a portable, hassle-free way to store multiple software authorizations. Move authorizations from home, to office, to the studio securely and easily with this convenient solution.

#DIPI  
**\$40<sup>00</sup>****LOGIC KEYBOARDS****Pro Tools Apple Wireless Keyboard**

- Bluetooth
- Pro Tools color- and icon-coded

#LOKBPTM  
**\$109<sup>95</sup>****LOGIC KEYBOARDS****Pro Tools Classic Keyboard For Windows**

- USB/PS2
- Pro Tools color- and icon-coded

#LOKBCPTW  
**\$99<sup>95</sup>**

**TRIPP LITE**

**Smart Pro 2600VA**

#TRSMART2600R  
**\$837<sup>95</sup>**

The Smart Pro 2600VA 9-Outlet UPS from



Tripp Lite is a rack-mountable, 9-outlet UPS and surge suppressor system. It delivers up to 18 minutes of half-load battery back-up and 480-joule surge suppression.

- Battery Independent, Dual Boost AVR Corrects Brownouts to 79V and Overvoltages to 147V
- Multiple Interfaces - 2 USB, 2 DB9, and SNMPWEBCARD Slot

**APC**

**Smart UPS 2200VA**

#APSUA2200RMZ  
**\$945<sup>95</sup>**

APC's Smart-UPS 2200VA slim line rack mount delivers



premium uninterruptible power and the most advanced performance features available. Also features audible alarms for powering conditions, hot-swappable battery, and a lifetime data-recovery warranty.

- Output power capacity: 2200 VA / 1980 watts
- Nominal input voltage: 120V
- Battery type: Maintenance-free sealed Lead-Acid battery with suspended electrolyte; leakproof

**ULTRA PRODUCTS**

**2000VA 1200W**

#UL2000V1000W  
**\$229<sup>95</sup>**



The UPS can provide up to 65 minutes of battery backup to a typical desktop computer. The compact UPS features six power outlets, four of which can provide battery backup, and modem surge protection.

- Line Interactive Design
- AVR (Automatic Voltage Regulation)
- Fully Digitized Microprocessor Controlled
- Protects up to 4 Devices at Once
- Energy Saving Function (UPS Green Mode)

**APC**

**APC Smart-UPS SC 620VA**

#APSC620  
**\$164<sup>95</sup>**



The UPS provides surge protection and battery backup via 4 outlets. The battery lasts up to 15.7 minutes at half-load capacity.

- Maintenance-free sealed Lead-Acid battery with suspended electrolyte
- DB-9 RS-232 interface port
- Alarm when on battery: distinctive low battery alarm

**BELKIN**

**F6C1500-TW-RK 1500VA**

#BEUPSTR1500  
**\$149<sup>95</sup>**

This feature-rich, dual form factor, small enterprise UPS provides connectivity options, network protection ports, telephone protection ports, and battery-protected outlets while providing industry-leading surge suppression capabilities and Automatic Voltage Regulation.



- Several USB/RJ-11/RJ-45/Serial ports
- 15 minutes at half load or up to 4 minutes at full load

**1000VA #BEUPSTR1000..... \$119.95**

**BELKIN**

**F6C1100-UNV 1100VA**

#BEUPS1100  
**\$109<sup>95</sup>**

The 1100VA features 4 battery backup outlets with surge protection and 2 surge-only outlets. With a capacity of 660 watts, this unit is geared towards mid-level computers and work stations.



- USB and Serial communication ports
- Data Recovery Warranty
- 1-In 1-Out RJ45 Surge Protection
- 6 surge-protected outlets, 4 with battery backup

**900VA #BEUPS900..... \$94.95**

**BELKIN**

**Gold Series Surgemaster**

#BESMC-9Q  
**\$41<sup>95</sup>**



The Gold Series offers top-level surge protection for your professional workstations. This model boasts 2950 Joules, 150,000 Maximum Spike Amperage, 9 outlets, and a lifetime Unlimited Connected Equipment and Data Recovery Warranties.

- 9 Surge-protected outlets supply complete, 3-line AC protection
- RJ45 network line with Ceramic Arrestor protection
- Solid-state 2-line/4 PIN phone DSL protection safeguards your modem, phone, and DSL lines

**TRIPP LITE**

**SMART750USB**

#TRSP700VAU  
**\$119<sup>95</sup>**



Tripp Lite's SmartPro 500 USB System provides intelligent, line-interactive battery backup for USB computers and workstations.

- Unique design features 6 outlets (3 UPS & surge + 3 surge-only)
- Diagnostic LED's
- Built-in USB communications port
- Built-in RJ11 jacks prevent surges from damaging your modem/fax equipment.



**COOL-BREEZE CD-ROM:****Pro Tools 7 CSI Starter,**

by Colin MacQueen

For anyone beginning to use Pro Tools for production, this interactive CD-ROM gives you the hands-on tips you need to be up and running quickly. Tutorials not only include functionality, but also production techniques, special shortcuts, and before-and-after audio examples.

#COCDRPT7S  
**\$22<sup>95</sup>****COOL-BREEZE CD-ROM:****Pro Tools 7 CSI Master**

Familiar with the basics of Pro Tools? This interactive Master edition CD-ROM covers all the major topics for polishing production skills. Movie tutorials teach advanced production techniques, special shortcuts, and use audio examples to further deepen user knowledge of Project Setup, Recording, Editing, Virtual Instruments, Synchronization, and more.

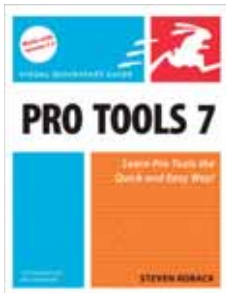
#COCDRPT7M  
**\$39<sup>95</sup>****PEARSON EDUCATION****Pro Tools 7 for Macintosh and Windows**

The task-based, visual instruction style of this Pearson QuickStart Guide makes it readily accessible to beginners and current users alike. It covers Pro Tools 7's newer streamlined interface, extensive MIDI features, file-management system, effects plug-ins, additional hardware support and much more. A great way to learn how to record, edit, and mix sophisticated, multi-track arrangements.

#PEVQGP7  
**\$29<sup>95</sup>****THOMSON DELMAR BOOK:****Pro Tools for Video, Film and Multimedia**

Designed for independent filmmakers, music engineers, and musicians composing and/or producing for film, video, and multimedia. This extensive guide gives in-depth coverage and tips on all aspects of syncing, editing, and mixing, various film file formats, and the equipment needed for producing professional film and multi-media projects.

#THPTVFM  
**\$29<sup>95</sup>****BERKLEE PRESS BOOK:****Producing in the Home Studio with Pro Tools**

Learn how to create great music at home with a comprehensive guide that teaches you fundamental production skills and engineering techniques. With a complete explanation of the entire production process, you will learn everything successful producers and engineers need to know to produce the highest-quality recordings.

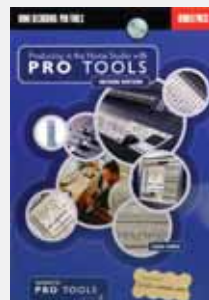
#BEPHSPT  
**\$34<sup>95</sup>****CHARLES RIVER MEDIA****Book and CD Rom:****Pro Tools Recording Guide**

Quickly learn the ins and outs of complete Pro Tools production with hands-on, step-by-step tutorials that focus on the essential features of the program. From input to output, users are guided through every aspect of audio production with helpful advice on how to handle different situations that may arise along the way.

#CHPTRG  
**\$39<sup>95</sup>****SECRETS OF THE PROS DVD:****Advanced Pro Tools Vol. 2**

This DVD follows its Vol.1 predecessor with over 2 hours of advanced tips on mixing and editing in Pro Tools, along with cool advice on topics such as file management, latency and buffer settings, and speedier navigation. The DVD also takes a good look at the various audio and MIDI upgrade features available in Pro Tools 7.x.

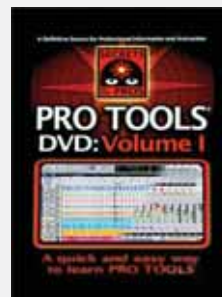
#SEVDAPT2  
**\$19<sup>95</sup>****SECRETS OF THE PROS DVD:****Pro Tools Vol. 1**

With more than 4 hours of expert advice, this easy-to-follow DVD tutorial covers LE & TDM Pro Tools systems for the Mac and PC. It covers not only the basics of setup, but goes much further into advanced techniques of recording audio, MIDI, editing, mixing and more, all in an easy-to-understand, detailed manner that covers the essentials and trade secrets of the pros.

#SEVDPT  
**\$39<sup>95</sup>**

### COOL-BREEZE CD-ROM: Logic CSI Starter

This CD-ROM provides almost 3 hours of movie tutorials for one of the industry's most intuitive audio creation tools. Designed to get beginners up and working quickly, this interactive training guide steps you through basic production, quizzing users along the way. Topics covered include Intro, Set Up, Recording, Editing, Mixing, and Delivery.

#COCDRLS  
**\$22<sup>95</sup>**

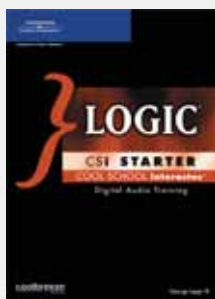

### COOL-BREEZE CD-ROM: Logic CSI Master

Logic is an advanced and powerful DAW that needs to be covered extensively. This CD-ROM provides exactly that, with almost 5 hours of movie tutorials. It offers user quizzes, covers the initial setup and functionality, and then dedicates a large portion of time to tips and techniques for the more advanced users. A full audio glossary is included.

#COCDRLM  
**\$37<sup>50</sup>**

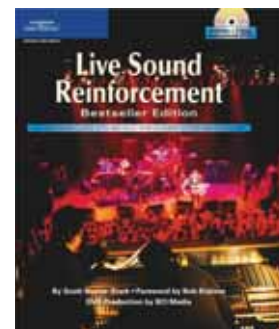

#THELTT  
**\$24<sup>95</sup>**

### THOMSON DELMAR BOOK: Emagic Logic

#### Tips and Tricks

Although it's aimed at experienced Logic users, Emagic Logic Tips & Tricks can benefit beginning users through its tips and insights into getting the most out of each of Logic's structural elements. Key factory commands are covered, saving users hours of production time, and complete chapters cover MIDI and audio editing tips, environments, DSP, project manager, and more.



### COOL-BREEZE CD-ROM: Nuendo CSI Master

Every major topic of this popular recording and post-production software is covered in full-movie tutorials. Suited for beginning and advanced users, setup, recording, processing, mixing, and mastering techniques and tips are covered within a unique learning environment.

#COCDRNM  
**\$37<sup>95</sup>**



### COOL-BREEZE CD-ROM: Digital Performer 4 CSI Starter

Digital Performer is an advanced Mac-based audio and sequencing software. This interactive CD-ROM is ideal for training beginners and more advanced users using step-by-step tutorials and quizzes focused on the major topics of setup, recording, mixing, and mastering your own CD.

#COCDRDP4S  
**\$29<sup>99</sup>**



### PEARSON EDUCATION Cubase SX for Mac and Windows VQS

This book offers comprehensive step-by-step coverage of audio and MIDI recording in Cubase SX software. The topics discussed range from audio fundamentals to advanced techniques like looping, mixer automation and tempo management. Clearly and logically presented, this book is a good resource for novices and pro users alike.

#COCDRS5S  
**\$22<sup>95</sup>**



### COOL-BREEZE CD-ROM: Sonar 5 CSI Starter

This CD-ROM covers the basic production development skills necessary for producing music and multi-media projects with this powerful PC-based software. Tutorials offer an easy-to-learn, intuitive learning environment covering special shortcuts, techniques, audio examples, and more.

#COCDRS5S  
**\$22<sup>95</sup>**



### COOL-BREEZE CD-ROM: Sonar 5 CSI Master

This hands-on tutorial provides a unique way to work through producing a song with this powerful software. It offers more than 4 hours of comprehensive movie tutorials with periodical quizzes to test your progress. Beginning and advanced functionality & production techniques are covered, along with special shortcuts, key commands, and before and after audio examples.

#COCDRS5M  
**\$39<sup>95</sup>**



**SONY MEDIA SOFTWARE DVD:****Sound Forge 8**

These DVD's provide you with the best and most qualified hands-on experience available for learning Sound Forge 8 software. Authored by the same people who wrote the software, this unique system provides you with not only a guided and interactive tour through the program, but also with the content you'll need to get the most out of this experience.



#SOPTSF8  
**\$79<sup>95</sup>**

**CMP BOOKS:****Instant Acid**

This Instant series guide uses carefully detailed screenshots and step-by-step directions to detail how you can use ACID in a concise, time-efficient way. Beginning with a review of the fundamental concepts, you get a complete guide to loop-based music, including advanced looping techniques, methods to create your own loops, as well as a grab-bag full of valuable tips and tricks.



#CMIA  
**\$19<sup>95</sup>**

#PEVQR3  
**\$21<sup>99</sup>**

**PEARSON EDUCATION BOOK:****Reason 3**

for Win/MAC

This tutorial book covers every aspect of the Reason 3 virtual rack plug-in. All the essentials are covered, including the sound banks, rear-rack cabling, effects, its polyphonic synthesizer, drum machine, sampler, mixer, and more, all presented in simple step-by-step instructions with plenty of visual aids to get you going quickly.



#COCDRAL5M  
**\$39<sup>95</sup>**

**COOL-BREEZE CD-ROM:****Abelton Live 5  
CSI Master**

This interactive CD-ROM takes you through more than 4 hours of tutorials, from basic setup and functionality to more advanced mixing and sequencing functions. The added features of Live 5 are thoroughly covered in movie and quiz form, testing your overall comprehension of this powerful and innovative sequencer instrument.

**COOL BREEZE CD-ROM:****Garage Band  
CSI Starter**

This CD-ROM provides almost 3 hours of movie tutorials for one of the industry's most intuitive audio creation tools. Designed to get beginners up and working quickly, this interactive training guide walks you through basic production, quizzing users along the way. Topics covered include Intro, Setup, Recording, Editing, Mixing, and Delivery.



#COCDRGS  
**\$22<sup>95</sup>**

**WAVES BOOK AND DVD:****Production, Mixing, Mastering:**

The Waves Production Book 3

This interactive DVD teaches mixing and mastering techniques used in the production of 5 contemporary musical styles, including R&B, Rock, Country, Urban and Alternative. The DVD uses all-original session files from major software DAW's for cross-platform, step-by-step analysis and re-mixing.

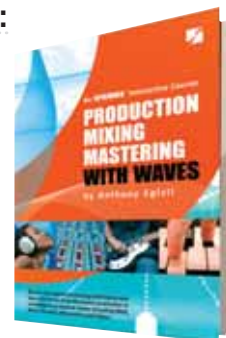

#WAPB3  
**\$59<sup>95</sup>**

#HASRHB  
**\$34<sup>95</sup>**

**HAL LEONARD BOOK:****Yamaha Guide to Sound  
Reinforcement Handbook**

Considered the ultimate source on live and installed sound, this book covers all aspects of designing and running sound systems for public address and musical performance. It covers audio theory, its practical applications, and full explanations of the equipment utilized in the creation and maintenance of basic or professional sound systems.

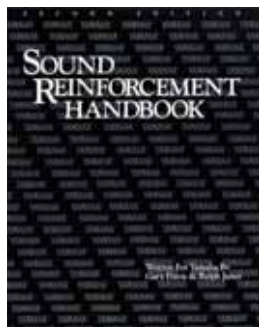

#HAGSSW  
**\$24<sup>95</sup>**

**HAL LEONARD BOOK:****Yamaha Guide to Sound  
Systems for Worship**

For everyone involved in church sound, this guide provides all the basic information to assist in the design, purchase, and operation of a system. Everything you need to know about the layout, choosing the right microphones, speaker setup, mixing, troubleshooting, and more is covered in easy-to-understand language.

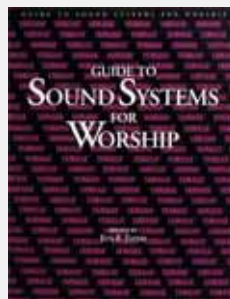



**SONY****Sound Forge 9 Tutorial Only**

This comprehensive tutorial DVD covers this ambitious audio recording and editing software from the essential to the esoteric. The DVD addresses topics ranging from audio restoration and analysis to sound design and stereo or multi-channel recording in an elegant and easily comprehensible manner.

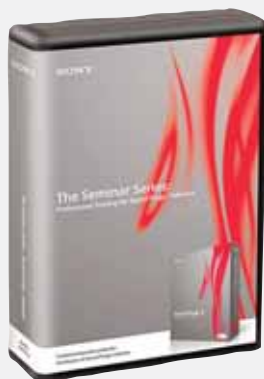
#SOSTSF2000  
**\$74.95****VAAST DVD:****Acid for Non-Linear Editors**#VAA  
**\$79.99**

With more than three hours of content, this DVD contains all the necessary information needed to score and compose with this revolutionary loop-based music production software. It covers everything from the hardware setup and creation of your own loops, to full production processing and remixing.

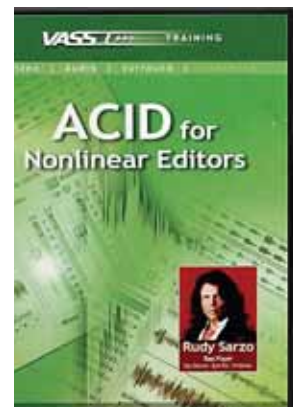
#ILBTGTMO  
**\$74.95****ILIO BOOK:****The Guide to MIDI Orchestration**

The Guide to MIDI Orchestration was written to help composers working with MIDI and samples to produce realistic-sounding compositions. It is an easy-to-read book that includes hundreds of screen shots, notated examples and graphics, all intended to provide a road map that will lead the reader through the complex tasks necessary for him to produce exceptionally realistic arrangements.

**FOCAL PRESS****Understanding and Crafting the Mix**

This book is written with engineers, sound designers and film mixers in mind at both the student and professional level. The book focuses on improved critical listening skills and sonic judgements at the mixing desk, and is supplemented by a CD-ROM full of audio clips and demos.

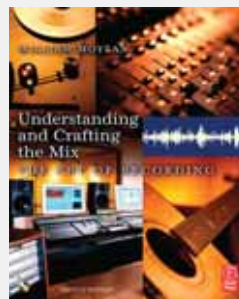
#FOUCM  
**\$34.95****BERKLEE PRESS BOOK:****Arranging in the Digital World**

This book is full of tips and tricks for beginning MIDI composers who want create inspired digital arrangements. A variety of contemporary styles are covered including pop, jazz, country, Latin, gospel, and more. Step-by-step sequencing, production and instrument-arranging techniques are all covered along with more than 50 sequenced MIDI examples.

#BEADW  
**\$19.95****SECRETS OF THE PROS DVD****The Basics of Modern Recording and Mixing**

This 2-DVD set leads you step-by-step through the often mystifying details of setting up your studio, recording, and mixing. With more than three hours of information, these DVD's will take you through standard methods of audio engineering that have been refined over decades by the experts. Find out how the best in the music business make world-class records, and learn how you can take advantage of their expert knowledge to get pro results every time.

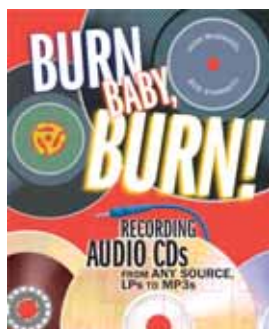
#SEVDMMR  
**\$39.95****PEARSON EDUCATION****Burn, Baby, Burn!**

This 300-page book is an exhaustive but breezy, jargon-free guide to recording high-quality CD's from a variety of sources including vinyl, MP3's, and digital audio streams. The book also includes a useful troubleshooting chapter, and enough tips and techniques to satisfy both the home enthusiast and pro engineer.

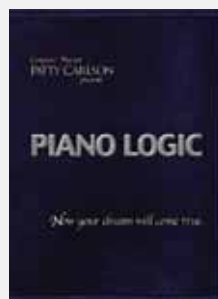
#PELACDB  
**\$19.95**#PIPL  
**\$89.95****PIANO LOGIC DVD:****Piano Logic DVD**

by Patty Carlson

Highly recommended for all ages, The Piano Logic DVD teaches, in simple terms, the vocabulary of music as a language. It allows you to understand how a composer uses the music vocabulary to write famous songs, apply it to your own songs, and then play the arrangements and compositions in multiple styles.

**SECRETS OF THE PROS****Advanced Pro Tools**

Volume 3

This DVD goes deeply into mixing "in-the-box" in the Pro Tools environment, exploring advanced automation techniques and plug-in use. Volume 3 also takes an extensive look at integrating control surfaces into the recording and mixing process, along with a detailed lesson on troubleshooting

#SEVDAPT3  
**\$24<sup>95</sup>****CMP BOOKS****Audio Postproduction for Digital Video** by Jay Rose

Jay Rose draws on his solid experience in the world of digital media production and presents a book that delivers a body of helpful methods that have been gathered by professionals over a large part of the past century. This book teaches the science and technique of studio voice and sound effect recording, editing both dialog and music, processing, and mixing. Written for results, it is full of practical tips, how-to examples, and time-savers that have been time-tested and proven in the field.

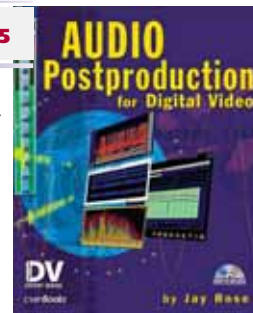
#CMAPDV  
**\$44<sup>95</sup>****HAL LEONARD****Audio Made Easy** by Ira White

This handy manual for musicians, studio engineers and audio pros contains valuable information on using EQ, speaker specifics, mics, and techniques for recording, live recording, club and concert sound, church sound, theatrical sound and much more, without page-filling formulas or mind-boggling abstractions. It includes lots of helpful diagrams, an updated digital mixing section, and an audio CD so that you can hear the techniques demonstrated in the book.

#HAAME4E  
**\$16<sup>95</sup>****NATIVE INSTRUMENTS****Traktor 3 Tutorial DVD**

The Traktor 3 Tutorial DVD takes a highly visual hands-on approach to operating this DJ-oriented recording and performance software in a lively manner that should appeal to both novice and professional DJ users. The 8 chapters and live footage section combine for over 4 hrs. of eye-opening techniques and applications for this powerful program.

#NADVDT3  
**\$39<sup>00</sup>****SECRETS OF THE PROS****Master Drummer**

Featuring Dennis Chambers A must-have instructional DVD for drummers and music fans alike, this disc is like a master class and a documentary video combined. Featuring performance and interview footage highlighting the life and work of one of the world's greatest musicians, recorded live and in a world-class studio.

#SEVDVMD  
**\$24<sup>95</sup>****PRESONUS****Cubase LE: Demystified**

With over 2 hrs. of step-by-step instruction, Cubase LE : Demystified covers all the features of the program, from setting up a project, recording, and overdubbing to advanced mixing and production techniques using MIDI, automation and Rewire integration. The DVD is designed to reveal the pro-level possibilities of Cubase LE software.

#PRCBASELE  
**\$29<sup>95</sup>****BERKLEE PRESS****Recording in the Digital World**

Recording in the Digital World provides professional advice and recommendations on studio gear, software, and the latest technologies allowing you to make the right choices in your studio and get the best possible results with your digital recordings. This is the most comprehensive guide available for professional musicians, music educators, and music hobbyists who want to explore this fascinating subject.

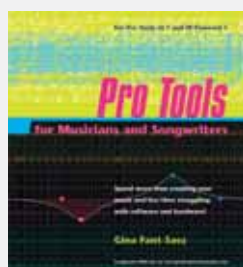
#BERDW  
**\$19<sup>95</sup>****PEARSON EDUCATION****Pro Tools for Musicians and Songwriters**

This comprehensive 544-page tome, written by a songwriter-musician for her peers, takes a thorough but non-technical approach to Pro Tools as a music-making tool. The author bypasses many of the program's more advanced engineering and production features, favoring instead the musician-friendly, tape-like aspects of multi-track recording and mixing in the Pro Tools domain.

#PEPTLE7MP7  
**\$44<sup>95</sup>**



**ASK VIDEO**

**Cubase 4 Level 1**

#ASC4L1  
**\$44.95**

Cubase 4 Level 1 is the first of a 3-part DVD tutorial series presenting the ins and outs of Cubase 4 in an informative, professional manner that anyone from the novice to seasoned pro will find useful. Much of the information applies to other versions of Cubase, and Nuendo as well.



- Cubase 4 Level 2** #ASC4L2 ..... **\$44.95**
- Cubase 4 Level 3** #ASC4L3 ..... **\$44.95**
- Cubase 4 Bundle** #ASC4TS ..... **\$124.95**

**ASK VIDEO**

**Mixing with the Pros**

#ASMWP  
**\$39.95**

This comprehensive tutorial DVD covers all aspects of the professional mixing session, with tips and techniques relating to level automation, EQ, dynamics and multi-effects processing that are equally applicable to both the hardware and software worlds. The focus here is on the concept of a mix as a unified, cohesive entity.



**ASK VIDEO**

**GarageBand**

#ASGARAB  
**\$29.95**

This instructional DVD is comprised of 28 graduated video lessons covering all aspects of navigating and operating the many features and processing components of Garageband software. The tutorial is well-presented and easy to use, and comes with 700 AppleLoops for Garageband from a variety of music developers.



**ASK VIDEO**

**Pro Tools Level 1**

#ASPROL1  
**\$49.95**

Pro Tools 4 Level 1 is the first of a 3-part DVD tutorial series covering all aspects of using one of the highest-profile DAWs in the industry. Tracking, editing, mixing, CD burning and archiving are covered thoroughly and logically throughout the series. A must-have for both HD and LE users.



- Pro Tools Level 2** #ASPROL2 ..... **\$44.95**
- Pro Tools Level 3** #ASPROL3 ..... **\$44.95**
- Pro Tools Tutorial Bundle** #ASPROL1L2L3 ..... **\$124.95**

**ASK VIDEO**

**Ableton Live**

#ASLIVE  
**\$39.95**

This DVD tutorial consists of more than 30 lessons and runs over 2 hours. Conducted by seasoned performer and power user Morg, the DVD covers every aspect of operating Ableton Live logically and transparently while demonstrating the program's features and applications in a variety of cutting-edge musical genres.



**ASK VIDEO**

**Reason 4**

#ASR4  
**\$44.95**

This tutorial shows off the power, flexibility, and versatility of Reason 4 software as a composing, mixing and performance tool. Packed with detail and presented from an insider's perspective in a manner guaranteed to make anyone a power user, this DVD offers extensive coverage of the upgraded arpeggiator, synth, sequencer and groove tool.



**ASK VIDEO**

**Melodyne Tutorial**

#ASR4  
**\$44.95**

The Melodyne tutorial DVD offers a personalized approach in presenting the unique editing features, audio quality, and production and sound possibilities found in Melodyne software. It contains 34 videos covering functions ranging from automatic pitch and time correction to the editing tools and MIDI synchronization.



**ASK VIDEO**

**Sibelius Tutorial DVD Level 1**

#ASR4  
**\$44.95**

Sibelius is one of the premiere music performance, notation and publishing programs in the industry, and this 25-lesson DVD, with a running time of over 2 hrs. is great for novices and a good reference source for more experienced users. The lessons cover everything from guitar tablature and lead sheet preparation to the basics of recording.



- Sibelius Tutorial Level 2** #ASSIBL2 ..... **\$39.95**
- Sibelius Bundle** #ASSB ..... **\$79.95**



**SOUND IDEAS**

**Series 2000**

The Sound Ideas Series 2000 Library is a 22-CD collection of digitally recorded and mastered stereo sound effects. This general SFX library set the standard for digital sound-effects production worldwide, providing a wide palette of high-quality effects, Foley sounds, and ambiances for multimedia and broadcast applications.



#SOS2000G  
**\$495<sup>00</sup>**

**SOUND IDEAS**

**Series 6000**

The Series 6000 "The General" Sound Effect Library is a huge, 40-CD collection of more than 7,500 royalty-free sound effects (more than 50 hrs of recorded sound). It offers a broad spectrum of sound clips including long ambient tracks from around the world, Foley sounds, and some truly spectacular audio from four award-winning sound designers.



#SOS6000G  
**\$1295<sup>00</sup>**

**SONY**

**Studios Sound Effects**

**Series Vol 1-5**

Sony Pictures Sound Effects Series Volumes 1-5 is a collection of 1,200 high-quality effects in various lengths and styles delivered in convenient WAV format. This 5-CD library is taken from the vaults of Sony Pictures Entertainment, and is ideal for multimedia, video post production, and broadcast applications.



#SOSSDS1000  
**\$249<sup>95</sup>**

**SOUND IDEAS**

**Series 10,000**

The 14-CD Ambience III sound effect collection provides 300 full-length ambience tracks collected from 28 different countries and national regions. 5 CD's are dedicated to New York City, including a comprehensive selection of backgrounds, ambiences, and signature sounds. This library packs in a total of 850 minutes of exceptional ambience sound effects.



#SOS10000A3  
**\$420<sup>00</sup>**

**SOUND IDEAS**

**The Library**

The Library Sound Effect Collection is a versatile six-CD collection that provides over 500 general sound effects at a very affordable price. This all-purpose collection includes a diverse selection of royalty-free sounds, making it a great starter library for multimedia, presentation, and broadcast post production applications.



#SOTL  
**\$199<sup>00</sup>**

**DIGITAL JUICE**

**Sound FX Library**

The Digital Juice Sound FX Library is a comprehensive collection of audio effects produced by renowned industry-veteran sound designers and distributed at 24-bit/96kHz resolutions. It uses a keyword-searchable index to navigate 10,000 sounds that are divided into more than 170 categories. This powerful library is ideal for audio/video post production applications.



#DISFX  
**\$599<sup>00</sup>**

**SOUND IDEAS**

**Crash & Burn**

Crash & Burn is a two-CD collection of over 400 sound effects that offers an impressive selection of destructive sounds and sequences. This comprehensive library includes: explosions, disasters, window breaks and glass smashes, body falls/body hits, rumbles, blasts, guns, bullets, and a host of other sounds of chaos and destruction.



#SOCB  
**\$199<sup>00</sup>**

**SOUND IDEAS**

**Power Surge 1-2**

Power Surge 1 is a two-CD collection of 319 high-energy sci-fi sound effects, ambiences, and alternate realities. This unique library of sounds includes: electrical sparks, arcs, and zaps, crashes, smashes, hits and punches, large impacts, guns, helicopters, electronic beeps and buttons, telemetry and computers, a full range of explosions, weather, and natural disasters.



#SOPS1  
**\$199<sup>00</sup>**

**Power Surge 2 #SOPS2.....\$199.00**

**SOUND IDEAS****BBC Sound Effects Library****Original Series**

The Library is a 40-CD collection that offers a wide selection of sound clips recorded by BBC's top engineers. It includes a full complement of exterior atmospheres, household, interior backgrounds, comedy, fantasy, humor, communications, water, industry, cars, hospitals, equestrian events, livestock, agricultural machinery, horses, dogs, schools, and crowds.

The BBC Sound Effects Library 20-CD 2nd Edition  
#SOBBC4160.....**\$345.00**



#SOBBC140  
**\$495<sup>00</sup>**

**SONOMIC****Library Card**

The Library card allows users to download either 50 samples or 20 sound effects from over 250,000 sounds available on Sonomic's comprehensive website. The website's intuitive search engine can audition and download the required clips. Sample libraries available include: Zero G, Sound Ideas, Universal Sound Bank, Q up Arts, Sampleheads, and more.



#SOLC  
**\$29<sup>95</sup>**

**SOUND IDEAS****Universal Studios**

The Universal Studios Sound Effects Library is a five-CD collection comprised of over 1000 classic sound clips, straight from the heart of some of Universal Studios' most famous and timeless feature film presentations. This amazing collection provides a large selection of top-quality effects ideal for a wide variety of creative applications.



#SOUS  
**\$179<sup>95</sup>**

**ULTIMATE SOUND BANK****UVI Soundcard X-Treme FX**

The UVI Soundcard X-Treme FX is a cross-platform plug-in or stand-alone virtual instrument containing over 5000 sound-effects presets organized by category. The software includes a player that accommodates both instruments and loops, and offers a host of playback controls, a handy preset browser, and tempo sync to the host sequencer.



#ULXFX  
**\$139<sup>00</sup>**

**SOUND IDEAS****Elements Café****DVD combo**

The Elements Café all-in-one collection is a single DVD ROM that contains the complete contents of all 10 Elements Café CD's (more than 3,500 production elements in all). The production elements are provided as 16-bit/44.1kHz broadcast .wav files, and this DVD disc also contains a fully-functional SuperSearch catalog for the complete collection.



#SOECDVD  
**\$695<sup>00</sup>**

**SOUND IDEAS****Turner Music Library**

The Turner Production Music Library is a 15-CD collection of professional quality, royalty-free music, exclusively distributed by Sound Ideas. It covers an incredible variety of musical styles and selections, in eight production-music categories using over fifty world class composers. It includes fully-orchestrated themes, signatures, logos, openers, and underscoring.



#SOTML  
**\$395<sup>00</sup>**

**SOUND IDEAS****Captain Audio**

Captain Audio is a collection of 450 sound effects in 16-bit/44.1kHz stereo .wav file format on CD ROM. It is ideal for website development, film and broadcast applications, multimedia presentations, providing a wide variety of both fantasy and real-life sounds. These web-ready audio files can be used on both Windows and Macintosh systems.



#SOCA  
**\$25<sup>00</sup>**

**SOUND IDEAS****Original Mix Signature Collection**

The Original Mix Signature Collection is a 24-CD bundle that includes 12 royalty-free production music libraries (380 themes, 1480 tracks). It includes: Rock Mix, Eazy Rock, Corporate Mix, Sports Mix, Eazy Listening Mix, Lite & Easy Mix, New Age Mix, Country Mix, Lite Jazz Mix, Jazz Mix Jazz, Classical Mix, Holiday Mix.



#SOMSCC  
**\$1195<sup>00</sup>**



**P5AUDIO**

**Gangs of NYC**

Gangs of NYC is a groove and sample library stocked with 25 multi-track construction loop sets done by Hip Hop engineer and producer eCity, evoking the grime and glory of NYC's boroughs and neighborhoods. The collection includes 250 individual loops, and all construction loop set parts are separated for individual treatment in the mix. These beats are hard, crafty, and recorded at 16-bit/44.1 CD-quality resolution.



#P5GNYC01  
**\$79<sup>99</sup>**

**P5AUDIO**

**Extreme Sound Effects**

Here are 110 in-your-face slammin' FX essentials for radio, music and sound effects production. For ease of use, they are delivered in individual WAV files and also as sampler kits for NN-XT, Halion, Battery, Kontakt and ESX-24 so that they can be integrated smoothly into your work environment. If you are in production this is a sound set that you cannot afford to be without.



#P5ESFX01  
**\$43<sup>99</sup>**

**P5AUDIO**

**Make 'Em Dance Pop Club Edition**



Here's a sample and groove collection consisting of 25 multi-track loop construction sets, recorded at CD-quality in the WAV file format, with all the instrument parts separated and individually looped. This volume is packed with enough hot, gritty, in-your-face sounds to cut through any mix and keep the dance floor packed and pumped. P5 Audio calls this edition "the lovechild of hip hop and pop" and that sums it up.

#P5MDPC01  
**\$59<sup>99</sup>**

**P5AUDIO**

**DRE Guitar Loop Chronicles**



This is a collection of 150 loops covering famed producer Dre's much-imitated electric guitar treatments on recordings from "The Chronic" through the present. The loops feature Dre's wah-wah stylings, delays, echoes, and special reverb treatments, all lovingly recorded on high-end Neve preamps and processed with an SSL channel strip. The entire collection is recorded at CD-quality 16-bit/44.1kHz resolution.

#P5DGLC01  
**\$51<sup>99</sup>**

- RNBF01** RnB Flavas V1 #P5RNBF01.....**\$55.99**
- RNBF02** RnB Flavas V2 (Groove Edition) #P5RNBF02.....**\$55.99**

**P5AUDIO**

**Ghetto Symphonies Vol. 1**

This is a collection of 25 loop construction sets in the production styles of 50 Cent, Akon and others working that territory. There are a total of 297 loops in the package, with each loop set containing completely separated kick, snare, hi-hat, bass, fx, synths and keyboards. All files are in 16-bit/44.1kHz WAV format.



#P5GHSYMP01  
**\$51<sup>99</sup>**

**P5AUDIO**

**Platinum Acoustic Guitar Loops Steel/Nylon Vol.1**

This collection includes over 270 sampled loops in stereo WAV file format of innovative and modern steel and nylon string acoustic guitar stylings culled from the Hip Hop, Neo Soul, R n' B, and dance genres. The loops were performed by seasoned session pros and recorded with high-end preamps and microphones under the supervision of a world-class production team.



#P5PAGLSN01  
**\$47<sup>99</sup>**

**P5AUDIO**

**Meteoric Rock Hybrid**



Meteoric Rock Hybrid is a collection of sampled loops in the Nu-Metal rock vein with verses, choruses, bridges and breaks. The loop sets, which are recorded as 16-bit/44.1kHz WAV files, feature all-live guitar, bass, drums, and keyboard performances; the drums alone are recorded on 8 separate tracks. The loops were performed by top-quality players and recorded using high-end gear in world-class facilities.

#P5METRH01  
**\$87<sup>99</sup>**

**P5AUDIO**

**Vinyl Scratch Master**



Vinyl Scratch Master is a huge 1200-sound sample library comprised of vinyl scratch patterns, SFX, drum cuts, and breaks divided into 26 vinyl scratch pattern kits and arranged into 13 commonly-used tempos. The CD-quality WAV files are supported by most software samplers, including Halion, EXS24, and Kontakt. You don't have to be a DJ to add vinyl spice to your tracks.

#P5VSM01  
**\$35<sup>99</sup>**



## BIG FISH AUDIO

### Straight Outta NYC

Straight Outta NYC represents the heart of East Coast Hip Hop in a collection of beats, grooves, and melodies in the Apple Loops, Rex, WAV, and RMX formats. Along with loads of beats there other elements included such as horns, guitars, synths, basses, clavs, fx, vocals and more. The construction kits separate drums for easy mixing, remixing, or mixing and matching across sets.



#BISONY1  
**\$62<sup>95</sup>**

## BIG FISH AUDIO

### Off the Hook Volume 3

Off the Hook Volume 3 is a sample library on DVD loaded with Hip Hop and R n'B loops grooves, bass lines and hits that are both hard and kind of pop at the same time. The massive set offers nearly 12GB of material, much of it WAV Rex or Apple Loops. There are 40 construction kits and two bonus folders full of drum loops and drum hits.

#BIOTH3  
**\$114<sup>95</sup>**



## BIG FISH AUDIO

### Latin Jazz by Peter Michael Escovedo



Peter Michael Escovedo is a master musician and arranger who has brought authentic Latin flavor and styling to countless pop recordings and live shows as a composer and musical director. His Latin Jazz sample collection consists of 40 construction kits teeming with Salsa, Rumba, Songo, Samba, Mambo and many other grooves from the Latin musical tradition.

#BILJPE1  
**\$99<sup>95</sup>**

## STOCK 20

### Library Collection 001



The Library Collection 001 is a massive 7-disc set of royalty-free stock music presented on CD-ROM. The library is divided into 37 song sets totaling 311 tracks that may be suitably matched to a wide variety of visual images. The music is designed for professional use by video editors in post-production applications.

#STLCO01  
**\$99<sup>95</sup>**

## BIG FISH AUDIO

### Slo' Motion: Tokyo Landscapes

This is a 2-DVD sample collection of ambient, chill-out-type loops, grooves and samples delivered at 60, 65 and 70BPM as WAV, Rex2 and Reason Refill files. The lush, slow grooves and soundscapes cover dub-style bass loops, evocative city sound FX, straight-up drum and percussion loops, and a variety of other ambient phrases suitable for New Age composition, sound design and trance applications.

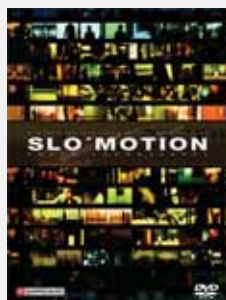

#BISLOM1  
**\$168<sup>95</sup>**

## STOCK MUSIC

### The Maximum Edge HD V5.0

The Maximum Edge HD V5.0 is the complete, royalty-free production music library available from Stock Music. Essentially a collection of 1300+ tracks, loops and sound effects accessible from both a USB 2.0 cross-platform drive and the Stock Music website upon purchase, the files are presented in MP3, WAV and AIFF formats. The buy-out license included with purchase allows for worldwide commercial use with no additional fees or permissions.



#STMAX005  
**\$1899<sup>95</sup>**

## BIG FISH AUDIO

### Rock Star

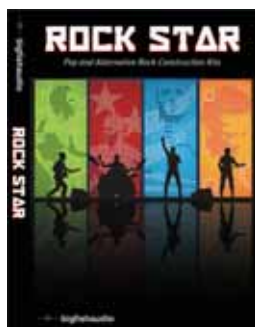

Rock Star is a 4GB sample DVD collection of Alternative Rock and Pop construction kits and loops, presented in AIFF/Apple Loops, Rex, Stylus RMX and WAV formats. The kits contain a full mix and alternate versions of the instruments, including leads and fills. The instrumentation includes electric and acoustic guitars, bass, drums, and piano, with tempos ranging from 90 to 180BPM. Over 90 bonus loops are also included.

#BIRKSR1  
**\$89<sup>95</sup>**

## SOUND IDEAS

### Immersion 5.1 Surround Sound Library



Immersion 5.1 is a massive collection of royalty-free surround sound ambiances with more than 220 tracks recorded, edited and mastered by the surround experts at Point One Sound. The library contains 7 24-bit/48kHz surround DVD's designed for direct audio import to the DAW of choice, and 7 stereo Red Book CD's intended for previewing the surround files or for stereo applications. Great for sound design, Foley or music production purposes.

#S0151SS  
**\$595<sup>00</sup>**

**SOUND IDEAS****MegaMix**

MegaMix contains almost 7,000 royalty free music tracks, more than 2,800 production elements, and 1,500 sound effects taken from the combined Mix Music and Mix Signature libraries and delivered to you on 20 DVD ROM discs. Choose from a full range of categories including classical, comedy & children, drama, easy listening, rock, jazz, dance & techno, holidays, military, sports, world, new age, and more.



#SOMEGAMIX  
**\$2595<sup>00</sup>**

**BIG FISH AUDIO****Soundscapes for Cinema**

This Apple Loop set gives you two gigabytes full of acoustic oddities, pads, atmospheres, exotic percussion loops, mixed loops, one-shot effects, tonal loops, eerie soundscapes and more from the award-winning Big Fish sound design library. Its strange noises and FX are perfect for your next film or music production and it is also sure to add those missing organic and electronic elements that you were searching for.



#BISSCO210  
**\$99<sup>95</sup>**

**SOUND IDEAS****Royalty Free Music Combo**

The Royalty Free Music Combo offers 12 first rate CDs of fresh music, in a wide range of genres and styles to complement your film or broadcast. There are more than 400 tracks in full length, alternative mix, and broadcast versions in such varied categories as easy listening, alternative rock, dance club, drama film score, extreme rock, hip-hop & house, tribute and wacky comedy.

#SORFMC  
**\$579<sup>95</sup>**

**BIG FISH AUDIO****Locked Groove**

Locked Groove contains over 300 exclusive techno loops from world-renowned techno producer and DJ Steve Stoll. They are designed for both the laptop DJ and techno producer, which you can mix together with your own sounds to create floor-filling techno, house and trance tracks. These loops come in WAV and Rex file formats, and the disc has been optimized for use with Ableton Live for a truly immersive experience.

#BILGSS1ARW  
**\$49<sup>95</sup>**

**BIG FISH AUDIO****Aquasky**

Over 1.5 GB of electro-house loops and breaks by acclaimed production outfit Aquasky with over 190 breakbeats and electro house drum-loops, 15 drum fills, 53 twisted bass loops, 167 inspirational music loops, and over 150 vocal samples from the Ragga Twins and Bex. Also included are over 300 heavyweight drum kit samples, 187 bass single hits, 55 fx hits, 15 fx loops and more than 200 instrument sounds.



#BILMAS01  
**\$41<sup>95</sup>**

**BIG FISH AUDIO****Dread**

Dread:Roots of Reggae gives you easy to use construction kits that are full of traditional reggae melodies and rhythms that reflect the music's roots in African music as well as American jazz and R&B. These loops come in AIFF, Apple Loop, Rex, WAV, and RMX formats and contain everything you need to produce great reggae tracks with essential instrument categories such as drums, bass, piano, guitar, horns, timbales, organ and more.



#BIDRRC2  
**\$84<sup>50</sup>**

**SONY PICTURES****FX Series Vol. 6-10**

This second installment of the Sony Sound Effects Series delves deeper into the intangible world of expert sound design. Explore the outer limits of science fiction, pick and choose from a variety of nail-biting horror soundscapes, or catapult your mind into the realm of the fantastic with hand-picked sonic elements from some of cinema's most imaginative films. Also includes a series of layerable 5.1 surround sound explosions.

#SOSSDS2000  
**\$249<sup>95</sup>**

**SONY SOUND SERIES****Boom Box Hip-Hop**

This huge set includes five CD collections of royalty-free loops: Hydroponic Hip-Hop, Mac Money: Electro Hip-Hop, Stylus Pressure: Urban Grooves On Digital Wax, Underground Soundlab, and Westside Underground. These ACID format loops will have you making polished tracks with no problem and include a variety of beats, basses, guitars, keys, vocal harmonies, FX, and much more.

#SOBLBH14  
**\$149<sup>95</sup>**



## SONY SOUND SERIES

### Bill Laswell Collection

The partnership of Sony Creative Software and star producer Bill Laswell constitutes the ideal pairing of technology and music. Laswell is known for his unique methods in making, listening to and conceptualizing modern music and sound. His music production is marked by total disregard for genre boundary restrictions and this ACID format set provides a rich construction kit for rock, funk, hip-hop, electronica, world music and ambient/cinematic.



#SOBLBLC1  
**\$169<sup>95</sup>**

## SONY SOUND SERIES

### Orchestral

This four volume collection of Classical, Modern, Cinematic and Rock & Pop ACID loops was assembled by an international team of gifted composers and producers and was recorded in Moscow with the full power and fury of a Russian symphony orchestra. Compositions feature both sections and individual parts and have been precisely edited to interact perfectly, providing you with the loops you need to conduct your own virtual symphony.

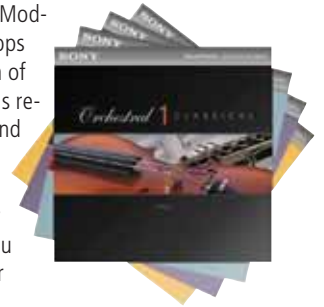

#SOBLOS4  
**\$139<sup>95</sup>**

## SONY SOUND SERIES

### Drums from the Big Room



Sony's Drums from the Big Room by world-class drummer Steve Ferrone and Grammy Award-winning producer Greg Ladanyi provides stacks of multitracked drum kit performance loops in five popular styles: rock, pop, R&B, jazz and reggae. All genres offer extensive performance loop choices, smartly configured into convenient packets of themed song structure elements that contain intros, verses, choruses, breaks, outros, one shots, and more.

#SOBLDBR13  
**\$169<sup>95</sup>**

## SONY SOUND SERIES

### Rock Shop

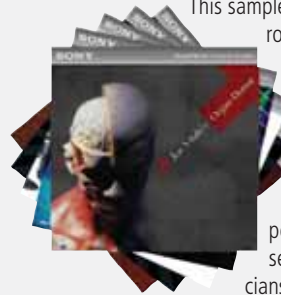

This sample library bundle delivers the time honored rock quartet lineup of bass, guitar, drums and keys in true style. Bradley Fish:Restrung, Jade Hill: Rock/Pop Guitars, Joe Vitale: Organ Donor, Sweet & Low Bass, and Tony Brock: Rock Drummer provide a library of over 3,400 original, royalty free ACID loops that is chock full of inspired performances. Now you too can employ the service of veteran session and touring musicians that bring your projects to life.

#SOBLRS16  
**\$149<sup>95</sup>**

## SONY SOUND SERIES

### Chicago Fire

This Dance Music Anthology consists of five construction kit libraries that explore five different aspects of the club music experience: deep house, electro, old school, progressive, and drum 'n bass. Vince Lawrence has assembled an amazing library of ACID loops that draw on his many years of experience and serve as a personal gateway to the hardcore Chicago sound. This set is a great construction kit for making incredible dance music.



#SOBLCF12  
**\$169<sup>95</sup>**

## SONY SOUND SERIES

### Scoring Pack

This ACID based collection can set the mood for any scene and is a perfect addition to the filmmaker's toolkit. Emotional Peak Sounds provides tension, stabs, and other sonic devices. Create soundscapes and moods with Spektral Minimalism or layer atmospheric rhythms and melodies with Robert Rich's Liquid Planet. Bring your symphonic side to life with the Orchestral Series and drop in stingers, staggers, and music beds from Cinematix 1.



#SOBLSPA6  
**\$149<sup>95</sup>**

## SONY SOUND SERIES

### Scoring Pack 2

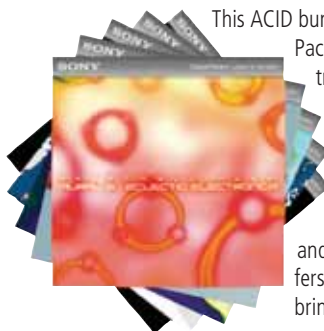

This ACID bundle is the sequel to the original Scoring Pack. Cinematix Volume II and Orchestral Volume II provide more film grade stingers and effects while adding 20th Century composition to your mix. Ugly Remnants Volume II adds unique, otherworldly sonic elements while Eclectic Electronica injects processed sounds and manipulated media. Finally, ILONA! offers three octaves of female vocal samples to bring the human touch to your score.

#SOBLSPB7  
**\$149<sup>95</sup>**

## SONY SOUND SERIES

### Scoring Pack 3



Scoring Pack III is the third part of this highly successful trilogy of film oriented ACID loops. This kit takes you even further into film scoring territory with the ambient Numina II, the two-CD set Slow Silhouette, Ugly Remnants I, the evolving Ma Ja Le: Ethereal Textures, and finally Orchestral Series IV which reinforces your rock and popular compositions with strings, brass, woodwinds and percussion.

#SOBLSPC8  
**\$149<sup>95</sup>**



- ABLETON**  
Live 7 ..... 85
- ACCESS MUSIC**  
Virus TI Desktop ..... 144  
Virus TI Keyboard ..... 140  
Virus TI Polar ..... 140  
Virus TI Snow ..... 140
- ACOUSTIC-RESEARCH**  
PR-391 ..... 332  
PR-392 ..... 332
- ADAM PROFESSIONAL AUDIO**  
A5 ..... 171  
A7 ..... 171  
P11A ..... 168
- ADOBE**  
Audition 2.0 ..... 87  
Soundbooth CS3 ..... 88
- AKAI**  
EWI4000S ..... 128  
MPC1000 ..... 132  
MPC2500 ..... 132  
MPC500 ..... 132  
MPD16 ..... 124  
MPD24 ..... 124  
MPK49 ..... 123
- AKG**  
AB4000 ..... 219  
ASU4000 ..... 219  
C542 BL ..... 244  
C1000S ..... 18  
C3000B ..... 5  
C414 B-XL II ..... 5  
C451B ..... 17  
C451B/ST ..... 17  
C535 EB ..... 228  
D112 ..... 234  
D230 ..... 187  
D5 ..... 228  
Elle C ..... 227  
K181 DJ ..... 273  
K240S ..... 163  
K240 MKII ..... 162  
K271S ..... 160  
K44 ..... 162  
K55 ..... 162  
Perception 100 ..... 11  
Perception 150 ..... 20  
PS4000 ..... 219  
RA4000B ..... 9  
Solidtube ..... 219  
SRA1 ..... 219  
ST305 ..... 356  
WMS40 ..... 210  
WMS 450 ..... 212  
ZAPD-21 ..... 219
- ALERA TECHNOLOGIES**  
Super Copy Tower ..... 422  
Auto Copy Tower ..... 422
- ALESIS**  
3630 ..... 51  
CD Twin LE ..... 39  
Control Pad ..... 124  
Cymbal Trigger ..... 124  
DMS ..... 143  
Fusion 6HD ..... 136  
Fusion 8HD ..... 136  
iMultimix 8 USB ..... 119  
iMultimix 9R ..... 119  
iO-14 ..... 75  
iO-2 ..... 70  
iO Control ..... 127  
M1 Active 320 ..... 175  
M1 Active 520 ..... 168  
M1 Active 620 ..... 168  
M1 Active MK2 ..... 168  
Micron ..... 141
- MicroVerb 4 ..... 44  
MidiVerb 4 ..... 44  
Multimix 12R ..... 252  
Multimix 12USB ..... 254  
Multimix 8 Firewire ..... 259  
NanoVerb ..... 45  
Pad Trigger ..... 124  
Performance Pad ..... 130  
PicoVerb ..... 45  
PowerTrip8 ..... 338  
RA150 ..... 280  
RA300 ..... 280  
RA500 ..... 280  
SR16 ..... 130  
SR18 ..... 130  
Sumo 300 ..... 155  
Transactive Mobile ..... 291  
USB-Mic Podcasting Kit ..... 119
- ALGORITHMIX**  
NoiseFree Pro ..... 91  
Scratch Free ..... 91
- ALLEN & HEATH**  
GL2400-32 ..... 256  
GL-2800-32 ..... 257  
GL2800848 ..... 257  
GR05 ..... 307  
GR2 ..... 306  
Mixwizard3 16.2 ..... 257  
Xone:02 ..... 266  
Xone:3D ..... 270  
Xone:92S ..... 268  
Xone2:62 ..... 268  
ZED-14 ..... 255
- ALPHA CASES**  
10032BTLG ..... 399  
10036BTLG ..... 399  
10046BTLG ..... 399  
10055BTLG ..... 399  
30016SCBLK ..... 399  
30024SCBLK ..... 399  
40022MM ..... 399
- AMBIENT AUDIO**  
ACC-501 ..... 369  
ACD-301 ..... 369  
ACD-301RF ..... 369
- AMPLIVOX**  
S250-OK ..... 334  
S350-OK ..... 334  
S350-MH ..... 334  
S350-MO ..... 334  
S350-WT ..... 334  
S450-MH ..... 335  
S450-MO ..... 335  
S610A ..... 287
- AMT**  
A95-4C ..... 240  
Roam 1 Elite ..... 212  
S15G ..... 239  
System 1 ..... 239
- ANCHOR AUDIO**  
ALB-40 ..... 215  
ALD-40 ..... 215  
AN-1000X ..... 289  
AN-130 ..... 288  
AN-130U1 ..... 288  
BEA-6000 ..... 290  
BEA-6000C ..... 290  
BEA-6000CU1 ..... 290  
BEA-6000CU2 ..... 290  
BEA-6000U1 ..... 290  
BEA-6000U2 ..... 290  
CC-25 ..... 287  
EXP-6000 ..... 288  
EXP-6000U1 ..... 288  
EXP-6000U2 ..... 288  
EXP-6001 ..... 288  
FL6000 ..... 335  
HBM-60 ..... 288, 290  
HC-1620 ..... 288  
HC-1650LX ..... 290
- LIB-6001 ..... 290  
LIB-6000H ..... 290  
LIB-6000HCU ..... 290  
LIB-6000HCU2 ..... 290  
LIB-6000HU1 ..... 290  
LIB-6000HU2 ..... 290  
Little Big Horn ..... 286  
LK-LIB ..... 335  
LK-XTR ..... 335  
LM-60 ..... 288, 290  
Mega-6000 ..... 288  
NL-6000 ..... 290  
NL-EXP ..... 288  
PB-25 ..... 287  
SC-50 ..... 288, 290  
SS-550 ..... 288, 290  
Tour-60 ..... 225  
WB-6000 ..... 288, 290  
WH-6000 ..... 288, 290
- ANTARES**  
Auto-Tune 5 ..... 92  
AVOX ..... 96  
Harmony Engine ..... 96
- APC**  
Smart-UPS SC 620VA ..... 425  
Smart-UPS 2200VA ..... 425
- APHEX**  
120A ..... 318  
228 ..... 347  
230 ..... 30  
320A ..... 49  
320D ..... 49  
323A ..... 49
- APOGEE**  
AD-16X ..... 63  
Big Ben ..... 66  
Cables ..... 383  
Duet ..... 69  
Ensemble ..... 76  
Rosetta 200 ..... 63  
Rosetta 800/192 ..... 63  
Symphony Bundle ..... 79  
Symphony PCI-X ..... 79  
X-HD card ..... 63  
XFW400 ..... 63
- APPLE**  
Cinema Display ..... 423  
iMac ..... 416  
Logic Express 8 ..... 86  
Logis Studio ..... 83  
MacBook ..... 417  
MacBook Pro ..... 417  
Mac Pro ..... 416
- ART**  
311 ..... 276  
406 ..... 159  
CableCOP ..... 349  
MacroMIX 4 ..... 250  
Model 418 ..... 303, 305  
Model 405 ..... 307  
Model 416 ..... 305  
Phantom II ..... 344  
Phantom III ..... 344  
PowerMIX 1 ..... 250  
Powermix 2 ..... 251  
PowerMIX 3 ..... 250  
Pro VLA ..... 51  
ProMIX 3 ..... 250  
SLA1 ..... 280  
SLA2 ..... 280  
T8 ..... 347  
TPS II ..... 33  
Tube MP ..... 33  
Tube PAC ..... 33  
X-Direct ..... 341
- ARTURIA**  
Analog Factory ..... 105  
Analog Factory Experience ..... 123  
ARP2600 V ..... 109
- Brass ..... 115  
CS-80 V ..... 109  
Minimoog V ..... 108  
Moog Modular V ..... 108  
Prophet V ..... 110
- ASHLY**  
4.24D ..... 318  
CLX-52 ..... 50  
LX-308B ..... 303  
MX-206 ..... 300  
MX-406 ..... 300  
MX-508 ..... 252  
PE800 ..... 280  
PE1200 ..... 280  
PE1800 ..... 280  
PE2400 ..... 280  
PE3000 ..... 280  
PE3800 ..... 280  
Protea 4.24C ..... 276  
SRA1450 ..... 316  
SRA4075 ..... 316  
TRA2075 ..... 92  
TRA2150 ..... 283  
TRA4075 ..... 316  
TRA4150 ..... 316  
XR1001 ..... 276  
XR2001 ..... 276  
ZR4001 ..... 276
- ASK VIDEO**  
Ableton Live Tutorial ..... 431  
Cubase 4 Tutorial ..... 431  
Garage Band Tutorial ..... 431  
Melodyne Tutorial ..... 431  
Mixing with the Pros ..... 431  
Reason 4 Tutorial ..... 431  
Sibelius Tutorial ..... 431
- ATI**  
BGD200-PPMP ..... 330  
DA10081 ..... 318  
DM200 ..... 63  
DMM-100 ..... 65  
DMM100BAT ..... 65  
WA100-1 ..... 63, 65
- ATLAS SOUND**  
AA120 ..... 315  
AD12BE ..... 355  
ADZ502W ..... 333  
ADZ612C ..... 333  
BE-E ..... 357  
CO1B ..... 355  
CP700 ..... 309  
DAT355T70W ..... 333  
DAT8ST ..... 333  
DS-2 ..... 356  
DS-5 ..... 356  
DS-7 ..... 356  
FASUB70 ..... 329  
GN13 ..... 357  
GN13E ..... 357  
GN19 ..... 357  
GN19E ..... 357  
GN6 ..... 357  
GN6E ..... 357  
IS125CS ..... 329  
IS139CS ..... 329  
IS149CS ..... 329  
LO2B ..... 356  
MS-10C ..... 358  
MS-25 ..... 358  
PB21XE ..... 357  
SD72W ..... 329  
SM52 Series ..... 325  
SM52T-B ..... 325  
SM82 Series ..... 325  
SM82T-B ..... 325  
TEB-B ..... 329  
TM-1 ..... 355
- BarbaBatch V4 ..... 89  
Speakerphone ..... 93
- AUDIO-TECHNICA**  
23ADP4 ..... 221  
23ADP7 ..... 221  
23ADP10 ..... 221  
AC100 ..... 218  
AC12 ..... 218  
AC25 ..... 218  
AEW-4110 ..... 209  
AEW-4240 ..... 209  
AEW-5266 ..... 209  
AEW-DA660D ..... 218  
AT2020 ..... 11  
AT3031 ..... 19  
AT3032 ..... 19, 20  
AT3035 ..... 7  
AT3060 ..... 9  
AT4040 ..... 6  
AT4041 ..... 18  
AT4050 ..... 5  
AT4051A ..... 17  
AT4053A ..... 17  
AT4053A-EL ..... 17  
AT4071A ..... 179  
AT4073A ..... 181  
AT8015 ..... 181  
AT8035 ..... 180  
AT803B ..... 184  
AT804 ..... 187  
AT808G ..... 242  
AT8415 ..... 180  
AT8116 ..... 353  
AT822 ..... 177  
AT825 ..... 177  
AT835B ..... 184  
AT8415 ..... 367  
AT8415 Deluxe ..... 367  
AT8416 ..... 356  
AT8416 ..... 242  
AT849 ..... 244  
AT8459 ..... 356  
AT8601 ..... 355  
AT8628A ..... 218  
AT8646QM ..... 356  
AT875R ..... 180  
AT8801 ..... 344  
AT8801 ..... 184  
AT892CLM3T ..... 248  
AT892CT4TH ..... 248  
AT892CTS ..... 248  
AT892CTH ..... 248  
AT892CWTH ..... 248  
AT897 ..... 180  
AT897 Basic Kit ..... 204  
AT899 ..... 185  
AT899A ..... 185  
ATH-M20 ..... 162  
ATH-M2X ..... 163  
ATH-M30 ..... 161  
ATH-M3X ..... 162  
ATH-M40FS ..... 161  
ATM250 ..... 237  
ATM250DE ..... 237  
ATM350 ..... 238  
ATM410 ..... 233  
ATM610 ..... 237  
ATM650 ..... 237  
ATM710 ..... 233  
ATM73A ..... 249  
ATM75 ..... 249  
ATW-1821D ..... 203  
ATW-1821D Deluxe Kit ..... 205  
ATW-1822D ..... 203  
ATW-1823D ..... 203  
ATW-2110 ..... 208  
ATW-2120 ..... 208  
ATW-3110 ..... 208  
ATW-3141AD ..... 208  
ATW-702 ..... 208  
ATW-A49 ..... 218  
ATW-A64P ..... 218  
ATW-BH1 ..... 218  
BP-4029 ..... 183  
CP8506 ..... 344  
Freeway 200 Series ..... 213  
Interconnect Cables ..... 383  
M2IEMS ..... 215
- M3IEMS ..... 215  
MB 1k/c ..... 232  
MB4K ..... 228  
Pro 42 ..... 244  
Pro 44 ..... 244  
Pro 45 ..... 246  
Pro 45W ..... 246  
Pro 47T ..... 242  
Pro 47TL ..... 242  
Pro 49Q ..... 242  
Pro 49QL ..... 242  
Pro 8HECW ..... 249  
Pro 8HEX ..... 249  
Speaker Cables ..... 383  
U851A ..... 244  
U851R ..... 244  
U851RW ..... 244  
U853A ..... 246  
U853AW ..... 246  
U853R ..... 246  
U853RU ..... 246  
U853RW ..... 246  
U857QL ..... 242  
U857QU ..... 242
- M5 ..... 25  
U5 ..... 25  
VT737SP ..... 24  
VT747SP ..... 48
- AVIOM**  
A-16D ..... 377  
A-16D Pro ..... 377  
A-16L1 ..... 377  
AN-16i ..... 377
- AZDEN**  
100HT ..... 198  
100LT ..... 198  
100LTH ..... 198  
1000BT ..... 203  
1000URX ..... 203  
1000URX/AB ..... 203  
1000URX/Si ..... 203  
1000URX/VM ..... 203  
1000XT ..... 203  
200ULH ..... 203  
200ULX ..... 203  
300LT ..... 200  
30XT ..... 200  
320ULH ..... 198  
320ULX ..... 198  
320ULX ..... 198  
320ULX ..... 198  
500LTS ..... 200  
51HT ..... 200  
51XT ..... 200  
APS-25 ..... 288, 324  
APS-25B ..... 288  
APS-IR ..... 288  
APS-UR ..... 288  
APS-VR ..... 288  
EPS12PC ..... 200  
EX505U ..... 200  
FMX-32 ..... 190  
FMX-42 ..... 190  
OM5 ..... 231  
OM7 ..... 227  
TR-40-MP ..... 20  
VX10 ..... 226
- AUDIX**  
ADX 20i ..... 238  
ADX40 ..... 247  
ADX40HC ..... 247  
ADX40W ..... 247  
CX-112 ..... 7  
D2 ..... 236  
D4 ..... 234  
DP-5A ..... 240  
DP-Elite 8 ..... 240  
F-90 ..... 239  
Fusion-7 ..... 240  
i5 ..... 236  
Micro-D ..... 238  
OM2 ..... 231  
OM2S ..... 231  
OM5 ..... 231  
OM7 ..... 227  
TR-40-MP ..... 20  
VX10 ..... 226
- AURALEX**  
Foamtak ..... 411  
ISO Producer Pack ..... 410  
LENRD Bass Trap ..... 411  
Max Wall 831 C ..... 410  
MoPADs ..... 411  
Platform Riser Isolation ..... 410  
Alpha-DST ..... 410  
DST-36C ..... 410  
SP-PROJ2CHA/CHA ..... 410  
SP-PROJ2CHA/BUR ..... 410  
SP-PROJ2CHA/PUR ..... 410  
SP-DLXPLUSCHA/CHA ..... 410  
SP-DLXPLUSCHA/BUR ..... 410  
SP-DLXPLUSCHA/PUR ..... 410  
Sonomatt 2" Panel ..... 411  
Studiofoam Pyramids 2" ..... 411  
Studiofoam Wedge 2" ..... 411  
Studiofoam Wedgies ..... 410  
Temp Tabs ..... 411  
Tubetak ..... 411
- B&H**  
Podcasting Kit ..... 118  
Vinyl Recording Kit ..... 264
- B-52**  
M1000V2 ..... 293  
M2000 ..... 293  
M2000 ..... 293
- BBE**  
DI 1000 ..... 340  
DI 100X ..... 340  
EQA131 ..... 54  
EQA215 ..... 54  
EQA231 ..... 54
- BEHRINGER**  
A500 ..... 280  
ADA8000 ..... 64  
B2030A ..... 172  
B2030P ..... 173  
B2031A ..... 172  
B2031P ..... 173  
B2092A ..... 173  
B212A ..... 295  
B215A ..... 295  
B-2 Pro ..... 7  
BCD2000 ..... 271  
BCF2000 ..... 126  
BCN44 ..... 126  
BCR2000 ..... 126  
BTR2000 ..... 389  
CT100 ..... 349  
CX2310 ..... 276  
CX3400 ..... 276  
DEQ1024 ..... 54  
DEQ2496 ..... 52  
DI20 ..... 342  
DI100 ..... 340

- DI4000.....343  
 DSP1124P.....55  
 DSP2024P.....45  
 EP1500.....280  
 EP2500.....280  
 FBQ1502.....54  
 FBQ2496.....55  
 FBQ3102.....54  
 FEX800.....44  
 HA4700.....159  
 HA8000.....159  
 HD400.....346  
 HPX2000.....273  
 K1800FX.....155  
 K3000FX.....155  
 K450FX.....155  
 K900FX.....155  
 MDX4600.....51  
 MON800.....157  
 MX-400.....251  
 MX882.....303  
 Podcaststudio Firewire.....118  
 Podcaststudio USB.....118  
 Rev2496.....46  
 RX1202FX.....305  
 RX1602.....305  
 Shark DSP110.....45  
 Tube Ultragrain Mic 100.....33  
 UBB1002.....253  
 UMX49.....121  
 VMX100.....267  
 VMX1000.....267  
 VMX300.....267  
 Xenyx 1204FX.....254  
 Xenyx 2442FX.....255  
 Xenyx 502.....252  
 Xenyx 802.....253  
 XM8500.....228
- BELKIN**  
 900VA.....425  
 1000VA.....425  
 FSU507 Hub.....424  
 F6C1100-UNV.....425  
 F6C1500-TW-RK.....425  
 F9G933-10.....425  
 OmniView SOHO Series.....424
- BENCHMARK**  
 ADC-1.....62  
 DAC-1.....62  
 DAC-1 PRE.....63
- BERKLEE PRESS**  
 Arranging in  
 the Digital World.....429  
 Pro Tools.....426  
 Recording in  
 the Digital World.....430
- BES**  
 Flexible Auger Bit.....332  
 Bell-1212.....332  
 Bell-3812.....332  
 Barracuda Fish Tape.....332  
 Contractor Tool Kit.....332  
 FIB-GUD.....332  
 LC-1025.....333  
 Magnafish.....332
- BEST**  
 Chris Hein Guitars.....114  
 Ethno World 4  
 Professional.....115
- BEYERDYNAMIC**  
 Detachable Cables.....374  
 DT108.....374  
 DT109.....374  
 DT150.....160  
 DT190.....374  
 DT250 250.....160  
 DT250 80.....161  
 DT280.....374  
 DT290.....374  
 DT770 M.....160  
 DT770 Pro.....160
- DT880 2005 Edition.....162  
 DT990 Pro.....163  
 M88 TG.....230  
 M130.....14  
 M160.....14  
 M58.....186  
 Opus 69.....230
- BIAS**  
 Deck.....87  
 Master Perfection Suite.....87  
 Peak Pro 5.....82  
 Soundsoap 2.....92  
 Soundsoap Pro.....101
- BIG FISH AUDIO**  
 Addictive Drums.....116  
 Aquasky.....436  
 Dread.....436  
 Elite Orchestral  
 Percussion.....117  
 Latin Jazz.....435  
 Locked Groove.....436  
 Off The Hook 3.....435  
 Rock Star.....435  
 Slo' Motion:  
 Tokyo Landscapes.....435  
 Soundscapes for Cinema 436  
 Straight Outta NYC.....435
- BLUE**  
 8-Ball.....235  
 Baby Bottle.....5  
 Ball.....234  
 Blueberry.....4  
 Bluebird.....8  
 Cactus.....383  
 Dragonfly.....9  
 Omni Mouse.....13  
 ROBBIE.....25  
 Snowball USB.....22  
 SnowflakeB.....22  
 Woodpecker.....14
- BLUE SKY**  
 BMC MKII.....156  
 EXO.....166  
 Media Desk 2.1.....168  
 Pro Desk 2.1.....168
- BOGEN/MANFOTTO**  
 Cable Path Tape.....386  
 Caution Cable Tape.....386  
 GS250.....316  
 MB8TSLVR.....329  
 MB8TSQ.....329  
 MB8TSQVR.....329
- BOOM AUDIO**  
 Kit Cool.....367
- BOOMMATE**  
 Boompole Cradle.....367
- BOSS**  
 BR1200CD.....60  
 BR1600CD.....60  
 BR600.....59  
 BR900CD.....60  
 DR3.....131  
 DR-670.....131  
 DR-880.....131  
 F56.....129  
 Micro BR.....58
- BOOMMATE**  
 Boompole Cradle.....367
- BSS AUDIO**  
 AR-133.....341
- CAD**  
 22A.....232  
 25A.....232
- C195.....232  
 D189.....232  
 DMTP-4.....241  
 DSM1.....355  
 E1002.....4  
 E-300.....10  
 E60.....237  
 GXL-3000.....13  
 M-177.....12  
 M-179.....8  
 M-9.....13  
 Trion 7000.....15  
 TSM411.....237
- CAKEWALK**  
 Dimension Pro.....111  
 Guitar Tracks Pro 3.....88  
 Kinetic 2.....106  
 Project 5 Version 2.....85  
 Rapture.....112  
 Sonar 7 PE.....82  
 Sonar Home Studio 6 XL.....84  
 Z3TA+.....112
- CALIPHONE**  
 CLS721.....222  
 CLS721-4.....222  
 CLS725.....222  
 CLS725-4.....222  
 CLS729.....222  
 CLS729-4.....222  
 P130-IRSYS.....225  
 PA 10A.....287  
 PA 10B.....287  
 PA-15.....286  
 PA-282AV.....286  
 PA-285AV.....286  
 PA-300 Plus.....287  
 PA-300 Plus Kit.....287  
 PA-8.....286  
 PA-916.....290  
 PA-916A.....290  
 PA-916B.....290  
 PA-916D.....290
- CANARE**  
 Cables.....383
- CASIO**  
 CTK 810.....153  
 CTK 900.....153  
 LK-100.....153  
 PBench.....363  
 Privia PX-110.....146  
 PX-575CS.....151  
 280A.....153  
 SA-75.....153  
 WK-3800.....152
- CELEMONY**  
 Melodyne Studio 3.....87
- CHANDLER**  
 EMI TG12413.....101
- CHARLES RIVER MEDIA**  
 Pro Tools  
 Recording Guide.....426
- CLAVIA**  
 Modular G2 Engine.....141  
 Nord Electro 2.....142  
 Nord Electro 2 Rack.....143  
 Nord Modular G2.....141  
 Nord Stage 88.....142
- CLEARSONIC**  
 A2-4 Amp Panel.....412  
 Isopac Series.....412
- CME**  
 Bitstream 3X.....122  
 UF400E.....122  
 UF50.....120, 122  
 UF60.....122  
 UF70.....122
- UF80.....122  
 VX5.....122  
 VX6.....122  
 VX7.....122  
 VX8.....122
- COMP BOOKS**  
 Audio Postproduction.....430  
 Instant Acid.....428
- COLES**  
 4104B.....187
- COMPREHENSIVE**  
 AAK.....351  
 Digital Audio Cables.....384  
 Mini Audio Cables.....384  
 Phone Cables.....384  
 RCA Cables.....384  
 XLR Cables.....384
- COMTEK**  
 AP230.....375  
 BST-25.....375  
 PR-216 TV 5/6.....375  
 RC-216.....375
- COOL BREEZE**  
 Abelton Live 5 CSI.....428  
 Digital Performer 4 CSI.....427  
 Garage Band CSI.....428  
 Logic CSI.....427  
 Nuendo CSI.....427  
 Pro Tools 7 CSI.....426  
 Sonar 5 CSI.....427
- COUNTRYMAN**  
 E6IHWT.....248  
 E6IUHWT.....248  
 E6WSBE.....353  
 EMW.....184  
 EMWHWBS.....184  
 Isomax 4.....242  
 Type 85.....341
- CROWN AUDIO**  
 1160A.....309  
 1160MA.....309, 311  
 140MPA.....309  
 14M.....306  
 180A.....309  
 180MA.....309, 311  
 180Max.....309  
 180Max PACK.....309  
 280A.....309  
 280MA.....309, 311  
 28M.....306  
 CM-700.....18  
 CD11000.....282  
 CD12000.....282  
 CM-200A.....232  
 CM-200ASW.....232  
 CM-30.....246  
 CM-30W.....246  
 CM-31.....246  
 CM-31W.....246  
 CM311A.....249  
 CM311AE.....249  
 CTS8200.....281  
 CTS8200USP/CN.....281  
 CTS8200VCA.....281  
 D45.....281  
 D75A.....281  
 IT4000.....282  
 IT6000.....282  
 IT8000.....282  
 LM-300A.....242  
 PCC-130.....244  
 PCC-160.....244  
 PZM-185.....245  
 SASSP MKII.....177  
 SG2.....245  
 XLS202D.....282  
 XLS402D.....282  
 XLS602D.....282  
 XLS802D.....282  
 XT11000.....283  
 XT12000.....283  
 XT14000.....283
- CRYSTAL PARTNERS**  
 Big Ears.....182  
 Lil Ears.....182
- CYCLING 74**  
 Max/MSP.....88  
 Mode.....109  
 Pluggo.....98
- DATRAX/BRYCO**  
 CDP60 Wall Mount  
 CD Case.....388  
 DP Portable DAT Case.....388  
 DRP Wall Mount  
 DAT Case.....388
- DBX**  
 131.....54  
 215.....54  
 223.....278  
 223XL.....278  
 231.....54  
 234.....278  
 234XL.....278  
 376.....31  
 1046.....50  
 2231.....53  
 286A.....31  
 AFS 224.....55  
 DriveRack 220i.....277  
 DriveRack 480.....277  
 DriveRack 4800.....277  
 DriveRack 4820.....277  
 DriveRack PX.....276  
 DriveRack PA.....277  
 DriveRack RTA-M.....277  
 iEQ15.....53  
 iEQ31.....53  
 Quantum II.....49  
 ZC1.....317  
 ZC2.....317  
 ZC3.....317  
 ZC4.....317  
 ZCBOB.....317  
 ZCFIRE.....317  
 ZonePro 1260.....317  
 ZonePro 1261.....317  
 ZonePro 640.....317  
 ZonePro 641.....317
- DENEKE**  
 GR-1.....368  
 TS-3.....369  
 TS-3BW.....369  
 TS-3EL.....369  
 TS-C.....369
- DENON**  
 DN-780R.....34, 35  
 DN-C550R.....39  
 DN-C615.....40  
 DN-C635.....40  
 DND-4500.....263  
 DN-D6000.....263  
 DN-HD2500.....264  
 DN-HP1000.....273  
 DN-S1000.....262  
 DN-S3500.....262  
 DN-T625.....41  
 DN-T645.....41  
 DN-X120.....265  
 DN-X1500S.....265  
 DN-X500.....265  
 DN-X900.....265  
 TU-1500RDP.....36
- DIGIDESIGN**  
 003 Factory.....77  
 003 Rack Factory.....77  
 Command 8.....125  
 DigiPack.....400  
 DINR LE.....100  
 DV Toolkit 2.....84  
 Hybrid.....110  
 Maxim.....100  
 Mbox 2.....68  
 Mbox 2 Micro.....71
- Mbox 2 Mini.....69  
 Mbox 2 Pro.....73  
 Music Production Toolkit 107  
 Pace iLok.....424  
 Reel Tape Suite.....91  
 RMT1.....169  
 SB-MB2.....400  
 Smack LE.....91  
 Strike.....117  
 Structure.....117  
 TL Space Native.....98  
 Velvet.....109
- DIGIGRAM**  
 UAX220v2.....71  
 VX222v2.....78
- DIGITAL JUICE**  
 Sound FX Library.....432
- DIGITECH**  
 Vocal 300.....47
- DORROUGH**  
 40-A.....330  
 40-C.....330  
 40-D.....330
- DPA**  
 4006-TL.....16  
 4088.....248  
 4088B.....248
- DURACELL**  
 9v Batteries.....385  
 AA Batteries.....385  
 AAA Batteries.....385  
 UA-101.....68  
 C Batteries.....385  
 D Batteries.....385
- DYNAUDIO**  
 BM15A.....164  
 BM6A.....164
- E-MU**  
 1616M.....81  
 PMS.....173  
 Proteus X2.....115  
 Xboard 25.....122  
 Xboard 49.....122  
 Xmidi-2x2.....67
- EARTEC**  
 SL.....376  
 SLD.....376  
 TD902VS.....376
- EARTHWORKS**  
 DK25/L.....240  
 DK25/R.....240  
 PND-4500.....21  
 SR20.....230  
 SR30.....230, 8
- EAST WEST**  
 Fab Four.....111  
 Symphonic Orchestra  
 Platinum.....115  
 Hardcore Bass XP.....104  
 Quantum Leap: Colossus.....106  
 Quantum Leap: Complete  
 Composers Collection 106  
 Quantum Leap: Goliath.....114  
 Quantum Leap: Gypsy.....107  
 Quantum Leap:  
 Ministry of Rock.....107  
 Quantum Leap:  
 Pianos.....111, 114  
 Quantum Leap:  
 Voices of Passion .106, 115  
 SD2.....115  
 StormDrum.....108  
 Symphonic Choirs.....103  
 Symphonic Orchestra  
 Gold.....110
- EAW**  
 CAZ1400.....283  
 CAZ2500.....283  
 CAZ800.....283  
 DX810.....317  
 DXRCV.....317  
 DXSW4.....317  
 SMS3.....325  
 SMS4.....325  
 SMS5.....325
- EBTECH**  
 HE-2.....345  
 HE-8.....345  
 Hum X.....344  
 Swixx Army Cable Tester 349
- ECHO**  
 Audiofire 8.....73  
 ECAF12.....73  
 Indigo DJ.....81  
 Layla 3G.....81  
 Mia MIDI.....79
- EDIROL**  
 FA-66.....72  
 M-10MX.....251  
 MA-15D.....175  
 MA-1EX.....175  
 MA-7.....175  
 PCR-300.....121  
 PCR-500.....121  
 PCR-800.....121  
 R-09.....192  
 R4.....194  
 R-4 Pro.....195  
 R-44.....196  
 SD-20.....145  
 UA-101.....68  
 UA-1EX.....70  
 UA-25.....69  
 UA-4FX.....70  
 UM-1EX.....67  
 UM-2EX.....67
- ELECTRO-VOICE**  
 205 Series.....326  
 309 Series.....326  
 405 Series.....326  
 409 Series.....327  
 635A.....187  
 AB-2.....219  
 ANU14.....219  
 APD4+.....210, 219  
 Blue Cardinal.....10  
 CLA-1.....219  
 CLA-2.....219  
 CLA-3.....219  
 CLA-4.....219  
 CLA-5.....219  
 CLA-6.....219  
 CP1200.....281  
 CP1800.....281  
 CP2200.....281  
 CP3000S.....281  
 CPSM.....243  
 DX38.....278  
 EVID 12.1 Series.....320  
 EVID 12.1P Series.....320  
 EVID 3.2 Series.....320  
 EVID 4.2 Series.....320  
 EVID 4.2 Series.....320  
 EVID C10.1.....327  
 EVID C4.2.....326  
 EVID C8.2 Series.....326  
 FAS00.....219  
 LPA500.....210, 219  
 MA1206.....310  
 MA1212.....310  
 MA606.....310  
 N/D468.....234  
 N/D767A.....227  
 N/D967.....228  
 PCS12.....243  
 PCS18.....243  
 PCS5.....243  
 Q44.....281

- Q66.....281  
RE16.....186  
RE-2 Series.....210  
RE20.....176  
RE20 Voice Over Kit.....176  
RE50B.....186  
RE90H.....246  
RE90P12.....243  
RE90P18.....243  
RE92H.....246  
RE97SB.....248  
RE97SBE.....248  
RE97TX.....248  
RE97TXB.....248  
REV Series.....213  
RM-D.....219  
RMS.....210  
SB122.....299  
SBA 760.....298  
SX100+.....296  
SX250.....296  
SX300.....296  
SX500.....296  
SXA100P.....294  
SXA250.....294  
SXA360.....294  
UAA-500.....219  
ZX1i-90.....324
- EVENT**  
ALP5-N.....172  
S100.....167  
Studio Precision 8.....165  
TR6.....173  
TR8.....165
- EVENTIDE**  
DSP4000B+.....42  
ECLIPSE.....42  
Reverb 2016.....46
- FENDER**  
P-80.....291  
PD-150.....290  
PD-500.....291
- FIXED NOISE**  
OTTO.....108
- FOCUSRITE**  
ComPounder.....50  
ISA 220.....25  
ISA 828.....28  
Liquid Channel.....24  
Liquid Mix.....95  
Red 3.....48  
Saffire.....75  
Saffire Pro 26 I/O.....74  
TrackMaster Pro.....31  
Twin Trak Pro.....30  
Voicemaster Pro.....29
- FOSTEX**  
6301BEAV.....167  
CR500.....38  
DV824.....196  
FR-2LE.....195  
MR-16HD.....60  
MR-16HD/CD.....61  
MR-8 MKII.....58  
MR-8HD.....58  
MR-8HD/CD.....58  
NX-6A.....172  
PM1 MKII.....173
- FRONTIER DESIGN**  
AlphaTrack.....127  
Tranzport.....127
- FURMAN**  
ADP1520.....337  
AR-1215.....337  
AR-20II.....337  
HA-6AB.....158  
IT-20II.....337  
Merit Series.....338  
PL-Pro D II.....338
- PL-Pro II.....338  
PlugLock.....337  
PM-Pro II.....338  
Power Factory Pro.....337  
PS-Pro II.....338  
PST-6.....339  
PST-8.....339  
RRM-2.....337
- EXPANSION**  
GURU.....86
- G-FORCE**  
Virtual String Machine.....111
- G-TECH**  
G-Drive Q.....420  
G-Raid 2.....421
- GALAXY AUDIO**  
AS-1000.....215  
CM-130.....331  
CM-140.....331  
CM-150.....331  
Micro Spot PM-B.....323  
Micro Spot PM-W.....323  
PA 5X140.....289
- GARFIELD**  
Headphone Softie.....388  
Tape Roll Bungee.....387
- GATOR CASES**  
DJ-I-Go iPod.....274  
GAV-1412R.....399  
GAV-1813R.....399  
GAV-20.....399  
GAV-DLX-1412R.....399  
GAV-DLX-20.....399  
GAV-PAK.....399  
GAV-PE-1412R.....399  
GDJ-DJ.....274  
GDJ-10X6.....275, 394  
GDJ-8X2.....275, 394  
GDJ-8X4.....275, 394  
GK-2110.....392  
GK-261R.....392  
GK-276R.....392  
GK-288R.....392  
GK-288-Slim.....392  
GK-4212.....392  
GK-49.....392  
GK-61.....392  
GK-76.....392  
GK-88.....392  
GK-88 Slim.....392  
GKB-49.....392  
GKB-61.....392  
GKB-76.....392  
GKB-88.....392  
GKB-88 Slim.....392  
GKBE-61.....392  
GKBE-76.....392  
GKBE-88.....392  
GK-LT25W.....399  
GM-1W.....398  
GM-1WP.....398  
GM-12B.....398  
GM-15.....398  
GM-2W.....398  
GM-4.....398  
GM-4WR.....398  
GM-5W.....398  
GM-6-PE.....398  
GM-7W.....398  
G-MIX 12X24.....396  
G-MIX 17X18.....396  
G-MIX 19X21.....396  
G-MIX 20X30.....396  
G-MIX 22X46.....396  
G-MIX 24X36.....396  
G-MIX-B 1212.....396  
G-MIX-B 1515.....396  
G-MIX-B 1818.....396  
G-MIX-L 1224.....396  
G-MIX-L 1618.....396  
G-MIX-L 1622.....396
- G-MIX-L 1822.....396  
G-Tour 10x12.....394  
G-Tour 10x14.....394  
G-Tour 10x16.....394  
G-Tour 12U.....390  
G-Tour 19x21.....396  
G-Tour 2U.....390  
G-Tour 20x30.....396  
G-Tour 24x36.....396  
G-Tour 4U.....390  
G-Tour 4UW.....390  
G-Tour 6U.....390  
G-Tour 61.....392  
G-Tour 76.....392  
G-Tour 8U.....390  
G-Tour 88.....392  
G-Tour 88 Slim.....392  
G-Tour CD-13x17.....275  
G-Tour CD-9x12.....275  
G-Tour M-15.....398  
G-Tour SHK-12 Cast.....390  
G-Tour SHK-4.....390  
G-Tour SHK-8 Cast.....390  
G-Tour T-Table.....275  
GPA-88.....401  
GPA-600.....401  
GPA-700.....401  
GPA-720.....396  
GR-10L.....390  
GR-12L.....390  
GR-2L.....390  
GR-35.....390  
GR-4L.....390  
GR-4S.....390  
GR-6L.....390  
GR-6S.....390  
GR-8L.....390  
GRB-2U.....390  
GRB-3U.....390  
GRB-4U.....390  
GRBW-2U.....390  
GRBW-3U.....390  
GRBW-4U.....390  
GRC-10x11 PU.....394  
GRC-10x12 PU.....394  
GRC-10x2.....394  
GRC-10x4.....394  
GRC-10x6.....394  
GRC-10x6.....394  
GRC-10x8.....394  
GRC-10x8 PU.....394  
GRC-12x10 PU.....394  
GRC-6x2.....394  
GRC-6x4.....394  
GRC-8x2.....394  
GRC-Base-10.....394  
GRC-Studio-2-GO AV.....399  
GRC-Studio-4-GOW AV.....399  
GRCP-10x6.....394  
GRCW-10X4.....394  
GRCW-10X6.....394  
GRR-10L.....390  
GRR-4L.....390  
GRR-6L.....390  
GRR-8L.....390  
G-Shock-12L.....390  
G-Shock-16L.....390  
G-Shock-4L.....390  
G-Shock-8L.....390  
GSR-2U AV.....399  
GSRW-2U.....399  
GX-1224-8.....396  
GX-1718-7.....396  
GX-1921-7.5.....396  
GX-20.....401  
GX-22.....401  
GX-3.....396  
GX-33.....363
- Gaffer Tape.....386  
Optical Media.....385  
Round Mic ID Flag.....388  
Square Mic ID Flag.....388  
Triangle Mic ID Flag.....388
- GITZO**  
G-556C.....366  
G-557C.....366  
G-7680C.....366
- GLYPH**  
GT 050.....421  
GT 050Q.....421  
GT 051.....421  
GT 060BR.....420  
GT 103.....420  
GT Key.....420  
PortaGig.....421
- GRACE DESIGN**  
M802.....27  
M902.....158  
M904.....156  
M904B.....156  
M906.....156  
Model 101.....27  
Model 201.....27  
A902RCU.....158
- GTC-INDUSTRIES**  
NP-1 Noise Plug.....386  
Tone Plug.....386
- HAL LEONARD BOOKS**  
Audio Made Easy.....430  
Yamaha Guides.....428
- HEAROS**  
Foam Ear Plugs.....388  
Music Series Ear Plugs.....388
- HEWLETT-PACKARD**  
LP2465.....423  
NW9440.....418  
XW4400.....418  
XW8400.....418  
XW9400.....418
- HHB**  
ADAT Tapes.....385  
CD-R.....385  
CDR 882.....38  
DAT Tapes.....385  
DTRS Tapes.....385  
DVD.....385  
DVD-R.....385  
DVD+R.....385  
FlashMic.....193  
Mini Disc.....385
- HIFI WORKS**  
HFWWP1.....333
- HITACHI**  
Microdrives.....385
- HORIZON MUSIC**  
Professional Snake Real.....379  
Stage Series.....379
- HOSA**  
8-Channel Snakes.....380  
Antenna Cables.....383  
Audio Interconnects.....380  
BNC Cables.....380  
CBT-375.....349  
CDL-313.....65  
CPR-800 Series.....379  
DIB-307A.....342  
Digital Cables.....380  
FCS-384.....129  
FCS-385.....129  
FCS-501.....129
- FSC-502.....129  
FSC-503.....129  
FSC-604.....129  
HEM-331.....345  
MIDI Cables.....380  
ODL-276A.....65  
ODL-312.....65  
ODS-330.....65  
PWA-421.....339  
PWD-401.....339  
SNU Series.....379  
Speaker Cables.....380  
WDC-427.....66  
XLR-800 Series.....379
- HPRC**  
AMRE 2300F.....405  
AMRE 2550WF.....405  
AMRE 2600WDK.....405  
PB-2650DK.....405  
PB-2850TBH.....405
- I-KEY AUDIO**  
I-Key Plus.....197
- IDEAL**  
T-Stripper.....333
- IK MULTIMEDIA**  
Ampeg SVX.....97  
AmpliTube 2.....94  
ARC.....90  
CSR-1.....99  
Philharmonik Miroslav.....109  
Sample Moog.....115  
Sonik Synth 2.....105  
StealthPlug.....72  
Total Studio Bundle.....94  
T-Racks.....94
- ILIO**  
Guide to  
MIDI Orchestration.....429  
Tassman.....112
- IMAGE-LINE**  
FL Studio FruityLoops.....89
- INTELIX**  
AVO-A2-PAC-F.....332  
AVO-A2-WP-PAC-F.....332
- INTER-M AMERICAS**  
A-120.....308, 314  
A-60.....314  
AC-R120M.....308  
CD-610.....37  
CD-660.....37  
LM-88A.....307  
PA-2000.....314  
PA-2312.....315  
PA-4000.....314  
PA-9348.....315  
PA-935.....308, 314  
PAM-120.....308  
PAM-CDA.....308  
PAM-T.....308  
PC-9335AD.....34  
PM-9208.....315  
PO-9106.....318  
PP-9213.....302  
PP-9214.....307  
PS-88A.....307  
PT-9107SD.....37  
PX-0288.....307  
QD-4240.....314  
SYS-2240M.....308  
TU-610.....37
- JL COOPER**  
MCS-3400.....125  
MCS-3400W.....125  
MCS-3800.....125  
MCS-3800W.....125  
PPS-2.....66
- JOE MEEK**  
MC2.....51  
OneQ.....30  
SixQ.....30  
ThreeQ.....32
- K&M**  
21020B.....359  
21110B.....357  
21202B.....357  
23110N.....356  
23500B.....355  
25910B.....361
- IZOTOPE**  
Ozone 3.....93  
RX.....90  
Spectron.....98  
Trash.....93
- JAZZMUTANT**  
Lemur.....125
- JBL**  
Control 1 Pro.....321  
Control 19 Series.....328  
Control 23 Series.....321  
Control 24 Series.....327  
Control 24 Micro Series.....327  
Control 25 Series.....321  
Control 25 AV Series.....321  
Control 26 Series.....327  
Control 28T60 Series.....322  
Control 29AV Series.....322  
Control 30 Series.....322  
Control 3 Series.....321  
EON10 G2.....295  
EON15 G2.....295  
EON15 P1.....295  
EONSUB G2.....295  
EON1500.....297  
ES10.....293  
E-System15.....293  
JRX1185.....299  
JRX1185P.....298  
LSR4326P.....165  
LSR4328P.....165  
LSR6312SP.....165  
LSR6328P.....165  
MRX512M.....296  
MRX515.....296  
MRX518S.....296  
MRX525.....296  
MRX528S.....296  
PRX512M.....295  
PRX515.....295  
PRX525.....295  
PRX535.....295
- K-TEK**  
K102.....366  
K102CC.....366  
K102CCR.....366  
K152CC.....366  
K152CCR.....366  
K202CC.....366  
K56CC.....366  
KA113CCR.....366  
KE100.....366  
KE100CC.....366  
KE110CC.....366  
KE69CC.....366  
KE79.....366  
KE79CC.....366  
K-HGW.....367  
K-SSM.....178
- KAMESAN**  
BP-1.....191  
KS-342.....191  
KS-6001.....191  
KS-6002.....191  
KS-T2000.....191  
KSPSM12BP.....191  
KSPSM12XLR.....191
- KATA**  
Banana-2.....402  
Banana-3.....402  
Koala-1.....402  
Koala-2.....402  
Koala-3.....402  
Koala-4.....402  
Mixer Pouch.....402  
OVH.....402  
Panda-402.....402  
Sundo-1.....402  
Sundo-2.....402
- KATAMOUNT**  
Scriptlinc.....368
- KB COVERS**  
PT-K-BC.....424  
PT-P-BC.....424
- KENSINGTON**  
Pocket Hub.....424
- KETRON**  
SD1 Plus.....150  
SD2.....145  
SD5.....151  
VEGA.....152
- KORG**  
Beatlab.....389  
BX-3.....142  
CX-3.....142  
D3200.....61  
D888.....59  
D77.....389  
DTR-1000.....389  
DTR-2000.....389  
Electrabe EMX-1.....133  
Electrabe ESX-1.....133  
EXB-PCM01.....154  
EXB-PCM02.....154  
EXB-SMPL.....154  
EXBUALLMP3.....154  
Kaossilator.....133, 139  
KDM-2.....389  
KP-3 KAOSS Pad.....44  
Legacy Collection.....105  
M3-61.....136  
M3-73.....136  
M3-88.....136  
M3-M.....145  
MicroKorg.....140  
MicroX.....138  
Mini-KP.....45  
MM-2.....389  
MR-1000.....197  
PAS50.....151  
PA800.....150  
padKontrol.....124



Pandora PX4A.....	56
Pandora PX4D.....	56
R3.....	141
Radias.....	139
Radias-R.....	139
TM-40.....	389
TR-61.....	134
X-50.....	138
X50 LE Camouflage.....	139

**KRK**

RP-5.....	174
RP-6.....	174
RP-8.....	174
VXT4.....	171
VXT6.....	166
VXT8.....	169

**KURZWEIL**

KSP8.....	42
PC1SE.....	137
PC1X.....	147
PC2R.....	144
PC3X.....	137
RSP8.....	42
SP2X.....	146

**LACIE**

d2 Quadra.....	420
Dupli Disc.....	422
Rugged.....	421

**LEATHERMAN**

Charge ALX.....	386
Fuse Tool.....	386
Leather Pouch.....	386
Wave Tool.....	386

**LECTROSONICS**

100 Series.....	199
400 Series.....	201
DM1612.....	317
DM1624.....	317
DM812.....	317
DM84.....	317
IFB Kit.....	375
MC100TRS.....	199
MC100XLR.....	199
RK150.....	353
RM.....	201
SM.....	201
SMBBCDN.....	201
SMBBCUP.....	201
SR Dual-Channel Series.....	200
UCR401.....	200
UH400.....	201
UH400A.....	201
VR Field.....	201
VRM2122.....	212
VRS.....	201
VRT.....	201

**LEXAR**

Compact Flash Cards.....	385
--------------------------	-----

**LEXICON**

Alpha Studio.....	71
MPX 1.....	43
MX200.....	43
MX400.....	43
MX400XL.....	43
Omega.....	70
PCM 81.....	46

**LIGHTWARE**

A2020-6.....	387
--------------	-----

**LIGHTWAVE**

A-5.....	366
A-5CC.....	366
G-5.....	366
G-5CC.....	366

**LINE 6**

Bass PODxt Pro.....	57
FBV Pedal Board.....	57
Guitar Port.....	56
Pocket Pod.....	56
POD X3.....	57
POD X3 Live.....	57
PODxt Pro.....	57
TonePort KB37.....	123
TonePort UX2.....	75
Variax 600.....	57

**LITTLITE**

L-2/12.....	387
-------------	-----

**LOGIC KEYBOARDS**

Pro Tools Covers.....	424
-----------------------	-----

**LPG****COMMUNICATIONS**

SB-215.....	368
SB-R3.....	368

**LUCID**

AD9624.....	62
DA9624.....	62
GENX192.....	66

**LUMIN-EZE**

BNC Lamp.....	387
Clamp-On Gooseneck.....	387
Mini Clamp-On Light.....	387
XLR Lamp.....	387

**LYNX**

Aurora 8.....	62
Aurora16.....	62
Lynx Two-B.....	78

**M-AUDIO**

Aries.....	229
Audio Buddy.....	33
Audiophile 192.....	78
Audiophile 2496.....	79
AV40.....	174
Axiom25.....	120
Axiom49.....	120
Axiom61.....	120
Black Box Pedal Board.....	57
Black Box Reloaded.....	57
BX10S.....	174
BX5A.....	171
BX8A.....	171
CO2.....	65
Delta 1010.....	80
Delta 1010LT.....	79
Delta 44.....	78
Delta 66.....	78
DMP3.....	32
Drum and Bass Rig.....	106
DX4.....	174
EX66.....	171
EX-P.....	129
Fast Track Pro.....	68
Fast Track Ultra.....	70
Fast Track USB.....	68
Firewire 1814.....	73
Firewire 410.....	73
Firewire Solo.....	72
GForce impOSCar.....	103
GForce M-Tron.....	103
GForce Minimansta.....	104
GForce Oddity.....	104
iControl.....	126
iDrum.....	113
JamLab.....	72
Key Rig.....	107
Keystation Pro88.....	123
KeyStudio 49i.....	121
Luna.....	6
M-Gear.....	400
Microtrack 2496 II.....	192
MidAir.....	121
Midisport 1x1.....	67
Midisport 2x2.....	67
Midisport 4x4.....	67

**Mobile Laptop**

Studio Bag.....	400
Mobile Pre.....	68
Nova.....	11
Octane.....	32
Oxygen 49.....	122
Oxygen 61.....	122
Oxygen 8 v2.....	122
Oxygen Tank.....	400
Pro Keys 88.....	146
Pro Keys 88SX.....	146
Pro Tools M-Powered.....	83
ProFire Lightbridge.....	64
Projectmix I/O.....	77
Solaris.....	13
SP-1.....	129
SP-2.....	129
Sputnik.....	13
Studio Pack.....	400
TORQ Connectiv.....	270
TORQ Exponent.....	269
Transit.....	71
Trigger Finger.....	124
UC-33E.....	126
UNO.....	67
X-Session Pro.....	269

**MACKIE**

1202VLZ3.....	254
1402VLZ3.....	255
1604VLZ3.....	256
1642VLZ3.....	256
402-VLZ3.....	254
406M.....	292
802-VLZ3.....	254
808M.....	292
808S.....	292
Big Knob.....	157
C200.....	297
C300Z.....	297
CFX12MKII.....	254
CFX16MKII.....	254
CFX20MKII.....	254
Control C4 Pro.....	125
Control Universal Pro.....	125
DFX-12.....	255
FR-1400.....	284
FR-2500.....	284
FR-800.....	284
HR624MK2.....	170
HR824MK2.....	168
M2000.....	283
M3000.....	283
M4000.....	283
MR5.....	170
MR8.....	170
Oynx 1200F.....	74
Oynx 1220.....	259
Oynx 1620.....	259
Oynx 1640.....	259
Oynx 800R.....	27, 259
Oynx Firewire Option.....	259
Oynx Satellite.....	75
Quad Comp/Gate.....	49
Quad EQ.....	52
S215.....	297
S218S.....	297, 299
S225.....	297
SA1521Z.....	294
SA1530Z.....	294
SA1532Z.....	294
SRM150.....	291
SRM350V2.....	295
SRM450V2.....	295
SWA1501.....	298
SWA1801Z.....	298
Tracktion 3.....	86
TT24.....	259

**MAGIX**

Samplitude V9.....	85
Sequoia.....	86

**MAG-LITE**

Mini Flashlight.....	387
----------------------	-----

**MAKE**

Finale 2008.....	83
Finale Allegro.....	89

**MARANTZ**

CDR310.....	194, 197
CDR420.....	197
CDR632.....	39
PMD570.....	35
PMD620.....	192
PMD660.....	194
PMD671.....	194
RC600.....	194

**MARATHON**

DCM-2000.....	266
MA-10MIX.....	275
MA-CDJ.....	275
MA-DCM.....	267, 275
MADJCD10WL.....	274
MADJCD12WL.....	274
MADJCD19WL.....	274
MA-DJX100.....	275
MA-M16UWLT.....	275

**MATTHEWS**

Sound Blankets.....	388
---------------------	-----

**MAXELL**

Cassette Tapes.....	385
DAT Tapes.....	385

**MCDSP**

Classic Pack.....	96
Emerald Pack.....	97
Project Studio.....	98
Revolver.....	99
Synthesizer One.....	113

**MCGRAW HILL**

Master Handbook of Audio.....	429
----------------------------------	-----

**MERIT-LINE**

Jewel Cases.....	385
CD Sleeves.....	385

**MIC-EZE**

FE5.....	354
Min-Eze.....	354
Pig-E-BAK.....	354

**MICROBOARDS**

CopyWriter Live.....	39
----------------------	----

**MIDDLE ATLANTIC**

D12.....	407
D12D.....	407
D2.....	408
D3.....	408
D4.....	408
Edit Center Stands.....	364
EDLG.....	407
EDSG.....	407
ELUR.....	407
ELUR+S12DG+D12DG.....	407
ESUR.....	407
HP.....	409
HW500.....	409
OBKR12.....	406
OBKR16.....	406
OBKR20.....	406
OBKR8.....	406
RC3.....	409
RC4.....	409
S12.....	407
S12D.....	407
S12DG.....	407
S24DG.....	407
U1.....	409
U3.....	409
U4.....	409
UTR1.....	409

**MOGAMI**

Gold Cables.....	383
------------------	-----

**MONSTER CABLE**

Interconnect Cables.....	381
Digital Cables.....	381
Instrument Cables.....	381
Speaker Cables.....	381
Midi Cables.....	381
AANM4.....	286
Direct Burial Speaker Cable.....	332

**MONSTER POWER**

100 IEC.....	339
200 IEC.....	339
AA Batteries.....	385
C Batteries.....	385
D Batteries.....	385
DJ Slip Matt.....	272
Flexlamp.....	336
Outlets To Go.....	339
Pro 1000.....	336
Pro 2500.....	336
Pro 3500.....	336
Pro 7000.....	336
Pro 800.....	339
Pro AVS-2000.....	336

**MOTU**

2408MK3.....	81
241/O.....	81
828 MK3.....	76
896HD.....	76
8PRE.....	74
Digital Performer 5.....	85
Digitar Performer 5 Upgrade.....	85
Ethno Instrument.....	113
FastLane USB.....	67
HD192.....	79
HD192E.....	79
HD192-PCI-E.....	79
Mach Five 2.....	108
Micro Lite.....	67
MIDI Express 128.....	67
MIDI Timepiece AV.....	66
MX4.....	102
Symphonic Instrument.....	103
Traveler.....	76
Ultralite.....	73

**MUSE**

Receptor Rev C2.....	144
----------------------	-----

**MUSIC XPC**

Professional C5.....	419
Professional M4.....	419

**MXL**

603S.....	19
Desktop Recording Kit.....	119
MXL M3.....	12
MXL V671.....	10
MXL V69.....	10
MXL V69M.....	12
USB.006.....	23
USB.007.....	23
USB.008.....	23

**NAGRA**

Ares-M.....	193
-------------	-----

**NATIVE****INSTRUMENTS**

Akoustik Piano.....	112
Audio 8 DJ.....	269
AudioControl 1.....	68
Battery 3.....	102
Battery 3 Updater.....	102
FMB.....	111
FMB Updater.....	111
Guitar Rig 3.....	93
Komplete 5 Collection.....	110
Kontakt 3.....	105
Kore 2.....	87

Massive.....	102
PRO-53.....	112
Reaktor 5.....	107
Reaktor 5 Updater.....	107
Traktor Scratch.....	269
Traktor 3 Tutorial DVD.....	430
Traktor DJ Studio 3.....	82

**NEUMANN**

BCM104.....	176
BCM104 Voice Over Kit.....	176
BCM705.....	176
BCM705 Voice Over Kit.....	176
KM183.....	16
KM184.....	16
KM184D.....	21
KM185.....	16
KMR81i.....	178
KMR82i.....	178
KMS105MT.....	226
RSM 191 A-S.....	183
TLM103A.....	4
TLM127/SETZ.....	7
TLM49.....	7
U87AI/SETZ.....	6

**NITE IZE**

Fiber Optic Adapter.....	387
Flashlite Friend.....	387
Headband.....	387
LED & Switch Upgrade Kit.....	387
Lite Bite.....	387
Magnetic Clip.....	387
Mini Pock-Its.....	387

**NOTEPAGE**

Feed For All.....	119
-------------------	-----

**NOTION MUSIC**

Notion.....	90
Progression.....	90
Protoge.....	90

**NOVATION**











198,000 products, at your leisure.

www.bhproaudio.com

PRODUCT DEMOS

PODCASTS

LIVE HELP

EXPANDED SEARCH

CUSTOMER REVIEWS







# STUDIO POWER in your POCKET

The POCKETRAK 2G is the smallest, easiest to use and most portable digital recorder available today. It easily fits in a shirt pocket so you can take it everywhere. The 2G features 2GB of built-in memory so you don't need external memory cards, and the built-in USB 2.0 connectivity makes it easy to transfer your linear PCM or MP3 recordings to and from your computer. Long battery life with the enloop battery technology, a high sensitivity tilt-up stereo microphone and built-in stereo speakers make the POCKETRAK 2G a complete recording studio in your pocket. The bundled Cubase AI4 DAW software lets you easily edit and master your audio recording on your computer.



1.7 Ounces and slim true pocket-sized design



Tilt-up mic for tabletop recording



Built-in speaker and headphone outs



Enloop rechargeable battery with up to 19 hours of battery life



Bundled Cubase AI4 DAW software for editing and burning CDs



Built-in 2GB memory and USB 2.0 for easy transfers to your computer

©2008 Yamaha Corporation of America. All rights reserved.  
www.yamahasyth.com



420 Ninth Avenue  
New York, NY 10001

Presorted  
Bound Printed Matter  
U.S. Postage  
**PAID**  
B&H PHOTO-VIDEO, INC.

To unsubscribe, visit [www.bhphotovideo.com/unsubscribe](http://www.bhphotovideo.com/unsubscribe)

**CURRENT RESIDENT OR**



# Pro Audio

- Computer Audio
- Pro Recording
- Live Sound/PA
- Installation Sound
- Broadcast/ENG



www.bhproaudio.com



Summer 2008

**HOURS OF OPERATION:**

Sunday: 10:00am – 5:00pm  
Monday thru Thursday: 9:00am – 7:00pm  
Friday: 9:00am – 2:00pm Saturday: Closed

800-416-5090 | 212-502-  
420 Ninth Avenue, New York, NY 10001 | [www.bhproaudio.com](http://www.bhproaudio.com)

**FREE SHIPPING**  
on most items  
(some restrictions may apply)

Summer 2008