

## LAVALIER MICS

### Miniature Condenser Microphones

Designed to be worn on the clothing of performers, Audio-Technica's miniature condenser microphones provide excellent yet unobtrusive sound pickup. Their mic element is enclosed in a rugged housing with low-reflectance finish and internal construction minimizes handling and clothing noise. The wide-range capability of these mics ensure clean, accurate reproduction with high intelligibility for lecturers, singers, and stage performers.



	AT-803b	AT-831b	AT-831R	MT830R
Frequency Response	30Hz - 20kHz	40Hz - 20kHz	40Hz - 20kHz	30Hz - 20kHz
Maximum SPL Input (Phantom/Battery)	135 dB / 121 dB	135 dB / 121 dB	141 dB	131 dB
Dynamic Range-Typical (Phantom/Battery)	106 dB/92dB	106 dB/92dB	112 dB	107 dB
Phantom Power	9 - 52v	9 - 52v	9 - 52v	9 - 52v
Battery Type	1.5V AA	1.5V AA	—	—
Low-Frequency Roll-off	18dB/oct @ 150 Hz	18dB/oct @ 80 Hz	—	—
Mfr# / B&H #	AT803 / AUAT803	AT831B / AUAT831B	AT831R / AUAT831R	MT830R / AUMT830R
Price	142.00	149.95	199.95	179.95

### AT803b

#### Omnidirectional Condenser Microphone

Intended to be worn on the clothing of performers for excellent, yet unobtrusive sound pickup. The wide-range capability of the AT803b ensures clean, accurate reproduction with high intelligibility for lecturers, singers, stage and TV performers.

- ◆ AA battery (up to 1200 hours) or 9-52v phantom power.
- ◆ 6' cable is provided between the mic and power module.
- ◆ A built-in 3-position switch on the power module allows selection of off, on/flat response, or on/low-roll-off.
- ◆ Includes clothing clip, windscreen and carrying case.

### AT831b/AT831R

#### Cardioid Condenser Microphone

Cardioid versions of the AT803b, the miniature AT831b and AT831R (phantom power only) are designed for hands-free applications in sound reinforcement systems. Cardioid pattern provides improved gain before feedback. Close-up voice pickup is crisp and clean, yet full sounding. Suppression of background noise is significantly better than that of full-size microphones. Same features and accessories as the AT803b.

### MT830R

#### Subminiature Omnidirectional Condenser Mic

The MT830R's wide-range capability ensures clean, accurate reproduction with high intelligibility for lecturers, singers, stage, TV performers and instruments. Runs on 9-52v phantom power only.

- ◆ 25' cable is provided between the mic and power module.
- ◆ Includes clothing clip and windscreen.

### Pro 70 Cardioid Condenser Lavalier Microphone

*This miniature condenser microphone achieves full-sounding pickup and is known for outstanding consistency and dependable performance. Supplied with a clothing clip, it provides natural and articulate vocal reproduction*



*when used as a clip-on lavalier. The Pro 70 is designed to make speech clearly and comfortably audible, yet never draw attention to itself or its operation. The versatile Pro 70 can be powered by battery or phantom power. Its cardioid polar pattern*

*reduces pickup of sounds from the sides and rear, improving isolation of the desired sound source. Low-frequency roll-off switch allows for reduced pickup of room noise.*

- ◆ Miniature condenser microphone ideal for vocal applications
- ◆ Corrosion-resistant contacts from gold-plated XLRM-type connector
- ◆ 6' cable is permanently attached between the microphone and the power module.

**Pro 70** Cardioid Lavalier Microphone (Mfr # PRO70 • B&H # AUPRO70) .....**99.95**

## LAVALIER MICS

### AT898 Subminiature Cardioid Lavalier Mic

*Designed to be worn as a lavalier or hidden in loose clothing, the discreet-design cardioid AT898 offers maximum intelligibility, accurate voice reproduction and unobtrusive appearance for use by lecturers, stage and television talent, and worship leaders. Its switchable low-frequency roll-off reduces sensitivity to popping. Battery or phantom power.*



- ◆ Maximum intelligibility and clean, accurate reproduction for lecturers, stage and television talent, and houses of worship
- ◆ Low-profile design (a mere 5mm in diameter) is ideal for applications requiring minimum visibility
- ◆ Switchable low-frequency roll-off reduces sensitivity to popping in close vocal use
- ◆ 9.8' cable attached to mic, TA3F connector at power module
- ◆ Operates on battery or phantom power
- ◆ Accessories include power module, clothing clip, viper clip, magnet clip and lanyard, two windscreens, three single and two double mic holders, battery and carrying case

**AT898 Lavalier Mic:** With 9.8' cable, TA3F connector at power module. (Mfr # AT898 • B&H # AUAT898) ..... **227.50**

**AT898c Lavalier Mic:** Same as the AT898, less power module. Underterminated 55" cable. (Mfr # AT898C • B&H # AUAT898C) ..... **139.95**

**AT898cL4 Lavalier Mic:** Same as the AT898, less power module. 55" cable terminated with Lemo connector for Sennheiser SK wireless systems. (Mfr # AT898CL4 • B&H # AUAT898CL4) ..... **193.50**

**AT898cT4 Lavalier Mic:** No power module. 55" cable terminated with TA4F connector for Shure wireless systems. (Mfr # AT898CT4 • B&H # AUAT898CT4) ..... **154.50**

**AT898cT5 Lavalier Mic:** No power module. 55" cable terminated with TA5F connector for ATW-U101 body-pack wireless system. (Mfr # AT898CT5 • B&H # AUAT898CT5) ..... **154.50**

**AT898cW Lavalier Mic:** No power module. 55" cable terminated with locking 4-pin connector for UniPak wireless systems. (Mfr # AT898CT5 • B&H # AUAT898CW) ..... **154.50**



### AT899

#### Subminiature Omnidirectional Lavalier Mic

*Designed for high-quality, unobtrusive operation, the AT899 provides maximum intelligibility and clean, accurate reproduction for vocalists, lecturers, stage and television talent, and houses of worship. A mere 5mm in diameter, the AT899 is ideal for applications requiring minimum visibility. The omni element is enclosed in a rugged, low-profile housing to minimize handling and wind noise.*

- ◆ Supplied accessory kit includes single and double mounts, clothing clip, viper clip, magnetic clip, two open-pore foam windscreens, and two metal mesh element covers and a convenient carrying case.

**AT899 Lavalier Mic:** With a permanently attached 9.8' cable and a 3-pin TA3F connection to the supplied AT8537 battery/phantom power module. (Mfr # AT899 • B&H # AUAT899) ..... **199.95**

**AT899c Lavalier Mic:** Same as the AT898, less power module. Underterminated 55" cable for custom applications. Available in Black (Mfr # AT899C; B&H # AUAT899C) and beige "theater" color (Mfr # AT899CTH • B&H # AUAT899CTH) ..... **139.95**

**AT899cL4 Lavalier Mic:** Same as the AT898, less power module. Underterminated 55" cable with Lemo connector for Sennheiser SK wireless systems. Available in Black (B&H # AUAT899CL4) and beige "theater" color (B&H # AUAT899CL4TH) ..... **193.50**

**AT899cT4 Lavalier Mic:** No power module. Underterminated 55" cable with TA4F connector for Shure wireless systems (Mfr # AT899CT4 • B&H # AUAT899CT4) ..... **154.50**

**AT899cT5 Lavalier Mic:** Same as the AT898, less power module. Underterminated 55" cable with TA5F connector for ATW-U101 body-pack wireless system. Black finish (Mfr # AT899CT5 • B&H # AUAT899CT5) ..... **139.95**

**AT899cT5-TH Lavalier Mic** Same as AT899cT5 but in beige "theater" color (Mfr # AT899CT5-TH • B&H # AUAT899CT5TH) ..... **154.50**

**AT899cW Lavalier Mic:** Same as the AT898, less power module. Underterminated 55" cable with locking 4-pin connector for A-T UniPak wireless systems. Available in Black (AUAT899CW) and beige "theater" color (Mfr # AT899CW-TH • B&H # AUAT899CWTH) ..... **159.95**

## B3

### Broadway Series Lavalier Microphone

The B3 is a very small, round, omnidirectional electret microphone specially-equipped to withstand moisture and makeup when placed in the hair or on the body. It will even survive an overnight bath in your favorite cola beverage. Extremely small, the B3 looks



great when you want to see it, hides easily when you don't. Hide it in hair of actors, news anchors and lecturers. Ideal for use in churches, schools and general lavalier applications, the B3 features up to 150dB SPL on 48v phantom power, has field-selectable high-frequency response, and with Kevlar reinforced cable and an ultra thin diaphragm, sets a new standard for low handling noise. Available in five colors (Black, White, Light Beige, Cocoa, Gray).



- ◆ Excellent choice for hair miking in theater work. Features include moisture resistance, small size, and flat frequency response.
- ◆ The protective cap on the B3 is easily removed for cleaning or replacement when clogged with makeup.
- ◆ Includes tie clip, wind screen, belt clip for connector and two high-frequency response control protective caps.

#### OPTIONAL ACCESSORIES FOR THE B3 AND B6:

Single Tie Clip .....	9.95	Magnetic Clip .....	12.95	Windscreen .....	5.95
Double Tie Clip .....	16.50	Viper Clip .....	9.95	Protective Cap .....	7.50

## B6 Incredibly Tiny Lavalier Microphone

Only one tenth of an inch (2.5mm) in diameter, the B6 is smaller than the cable of other lavalier microphones, yet out performs microphones many times its size. The B6 is effectively hidden when it's in plain sight. For example choose a protective cap near the color of a shirt and poke the B6 out through a button hole. Tape the cable to the back of the shirt to secure it and your done. Say goodbye to the hassle and degraded sound quality you get burying mics under clothing! Hide it in hair or glue on the faces of actors, news anchors and lecturers. It is designed to survive.

Highly resistant to moisture, makeup and other hazards found in a production environment, the B6 will even survive an overnight soak in your favorite cola beverage. The outer screen in the B6's replaceable cap stops makeup and sweat before it enters the mike element. If it clogs, simply remove the cap for cleaning or replacement. The B6 includes a tie clip, wind screen, belt clip for connector and a set of three high frequency protective caps so you can match your application.

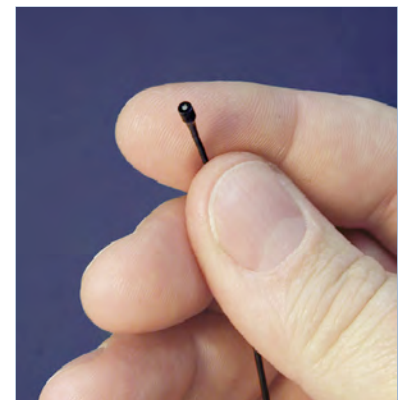

Highly resistant to moisture, makeup and other hazards found in a production environment, the B6 will even survive an overnight soak in your favorite cola beverage. The outer screen in the B6's replaceable cap stops makeup and sweat before it enters the mike element. If it clogs, simply remove the cap for cleaning or replacement. The B6 includes a tie clip, wind screen, belt clip for connector and a set of three high frequency protective caps so you can match your application.

**B3** How protective caps change frequency response.

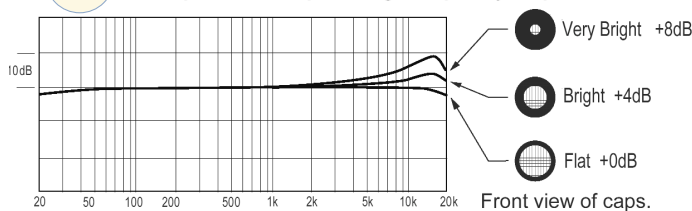

**B6** How protective caps change frequency response.

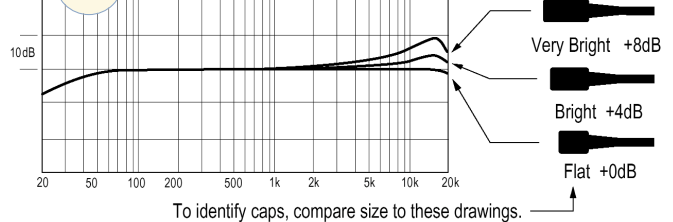

**EMW**

## Square Omnidirectional Lavalier Microphone

The Countryman EMW is a multi-purpose lavalier microphone designed for churches, schools, interviews, news etc. It features an omni-directional polar pattern, yielding an even frequency and signal response at the direct and indirect sections of the microphone. It features a wide 20Hz to 20kHz frequency response, and is also available in flat (instrument miking, shelved (normal lavalier use) and peaked (for use behind clothing) frequency response curves. It is highly water resistant and is available in five colors (Black, White, Light Beige, Cocoa, Gray). It includes a viper grip clip, a tie clip, a wind screen and a soft case.

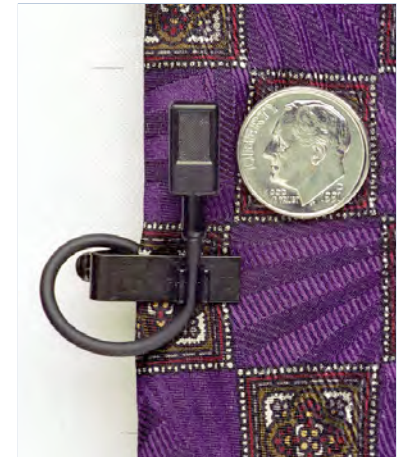

### MICROPHONES FOR WIRELESS

Manufacturer	Mic System	Connector Type	B3 Omni Lav Mic	B6 Omni Lav Mic	EMW
AKG	PT40, 60, 61, 80, 8, 2000, 4000	Switchcraft TA3F	B3W[ ]FF05[ ]AK	B6W[ ]FF05[ ]AK	MEMW[ ]05[ ]AK
	PT51, 300, 900	B-LOC (3.5mm)	B3W[ ]FF05[ ]AG	B6W[ ]FF05[ ]AG	MEMW[ ]05[ ]AG
Audio-Technica	T27, 31, 51, 210, 310, 3000	Hirose 4-pin	B3W[ ]FF05[ ]AP	B6W[ ]FF05[ ]AP	MEMW[ ]05[ ]AT
	T35, 75, 211, 601, 1000	Hirose 4-pin	B3W[ ]FF05[ ]AW	B6W[ ]FF05[ ]AW	MEMW[ ]05[ ]AN
Azden	41BT (UHF)	Hirose 4-pin	B3W[ ]FF05[ ]ZU	B6W[ ]FF05[ ]ZU	MEMW[ ]05[ ]ZU
Beyer	TS170, 170p, 190	Lemo "S" 4pin	B3W[ ]FF05[ ]BS	B6W[ ]FF05[ ]BS	MEMW[ ]05[ ]BS
Lectrosonics	M170, 175	Switchcraft 851	B3W[ ]FF05[ ]L2	B6W[ ]FF05[ ]L2	MEMW[ ]05[ ]L2
	U100, 190, 195, 200, 300, M185	Switchcraft TA5F	B3W[ ]FF05[ ]LS	B6W[ ]FF05[ ]LS	MEMW[ ]05[ ]LS
	M187, UM190, 195, 200, 250, 300	Switchcraft TA5F	B3W[ ]FF05[ ]LX	B6W[ ]FF05[ ]LX	MEMW[ ]05[ ]LS
Nady		Lemo 4-pin	B3W4FF05[ ]NL	B6W4FF05[ ]NL	MEMWF05[ ]NL
		Switchcraft TA3F	B3W4FF05[ ]NS	B6W4FF05[ ]NS	MEMWF05[ ]NS
Samson	UT5, TX3 (Black)	Hirose 6-pin	B3W[ ]FF05[ ]SA (X)	B6W[ ]FF05[ ]SA (X)	MEMW[ ]05[ ]SX
	CT3, VT2L	Switchcraft TA3F	B3W[ ]FF05[ ]SV	B6W[ ]FF05[ ]SV	MEMW[ ]05[ ]SV
Sennheiser	SK2012	Microdot	B3W[ ]FF05[ ]SE	B6W[ ]FF05[ ]SE	MEMW[ ]05[ ]SE
	SK-50, SK250	Lemo 3-pin	B3W[ ]FF05[ ]S3	B6W[ ]FF05[ ]S3	MEMW[ ]05[ ]S3
	BF1083	Lemo 1-pin	B3W[ ]FF05[ ]S1	B6W[ ]FF05[ ]S1	MEMW[ ]05[ ]S1
	SK 1093 digital	3.5mm locking plug	B3W[ ]FF05[ ]SD	B6W[ ]FF05[ ]SD	MEMW[ ]05[ ]SD
	Evolution Series EW100, 300, 500	3.5mm locking plug	B3W[ ]FF05[ ]SR	B6W[ ]FF05[ ]SR	MEMW[ ]05[ ]SR
Shure	L-1, L-11, LX1, SC1, U1, T1	Switchcraft TA4F	B3W[ ]FF05[ ]SL	B6W[ ]FF05[ ]SL	MEMW[ ]05[ ]SL
	U1L	Lemo 4-pin	B3W[ ]FF05[ ]SU	B6W[ ]FF05[ ]SU	MEMW[ ]05[ ]SU
Sony	WRT-28, 420, 820	Twist-lock type 4-pin	EB3W[ ]FF05[ ]SO	B6W[ ]FF05[ ]SO	MEMW[ ]05[ ]SO
	WRT822, WRT8B	Twist lock type 4 pin	B3W[ ]FF05[ ]SY	B6W[ ]FF05[ ]SY	MEMW[ ]05[ ]SY
	WRT-805, URX-B1	3.5mm locking plug	B3W[ ]FF05[ ]SN	B6W[ ]FF05[ ]SN	MEMW[ ]05[ ]SN

If your wireless system is not listed here, give us a call or check our website for additional models (many more are available). When ordering, please specify desired color and microphone sensitivity.

**4080****Miniature Cardioid Lavalier Microphone**

Combining optimum speech intelligibility with a discreet, compact design, the DPA 4080 is well suited for broadcast, conference, and other live performances in the studio or in the field. The frequency response of the DPA 4080 lavalier is tailored to body-worn applications. It is acoustically pre-equalized, offering a 4 dB presence boost, which makes the voice more distinguishable and improves speech intelligibility. Just 1.2" long and 0.5oz., the 4080 sets a new standard for great sound in a sleek design. Because of the flexible and practical mounting solution, the microphone can easily be turned in all directions and fits both left and right buttoned shirts. The 4080 is delivered with a pre-mounted pop filter in a holder with an integrated shock mount, fixed on a clip. Because of the flexible and practical mounting solution, the microphone can easily be turned in all directions and fits both left and right buttoned shirts.

**4080:** Cardioid Lavalier Microphone (Mfr # 4080-BM • B&H # DP4080BM) .....**529.95**

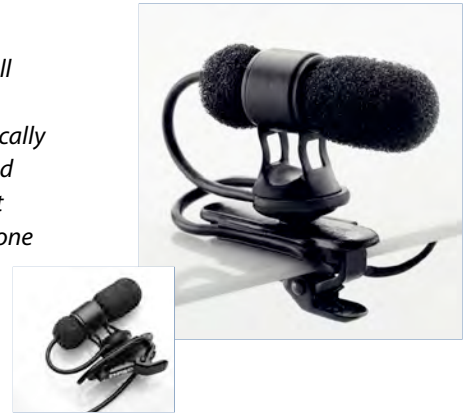
**4071****Miniature Omnidirectional Lavalier Microphone**

The 4071 features a specially designed, fixed microphone grid with a soft presence boost of 5dB at 4-6kHz. Speech intelligibility, clarity and definition of voices lie within the area that the 4071 grid boosts. While clarity seems to be missing from chest-worn mic placement, the 4071 will make voices cut through. Typical applications are ENG/EFP use on the reporter in studio or in the field, or film production use, with hidden mic placements on the actors. When recording voices from mic placement on a performers body, no frequency below 100Hz is attractive. For this reason, an acoustical low-cut has been incorporated in the 4071 capsule so the built-in pre amp will have much larger headroom.

**4071-BM:** In Black  
(Mfr# 4071-BM • B&H# DP4071BM).....**459.95**

**4071-WM:** In White  
(Mfr # 4071-WM • B&H # DP4071WM).....**459.95**

**4071-FM:** In Beige  
(Mfr # 4071-FM • B&H # DP4071FM) .....**459.95**

**EMK4071 ENG/EFP Microphone Kit**

This ENG/EFP microphone kit is for use when the microphone is allowed to be visible. The kit contains a 4071-BM miniature microphone (pre-equalized for speech clarity) and various fixtures for the microphone. Included is also an XLR adaptor with midrange attenuation (DAD6024), which is the final tonal adjustment needed for going directly on air or to tape without editing. A combination of 4071 and DAD6024 makes voices more distinguishable and improves speech intelligibility and definition. Includes: Miniature Mesh for 4071 (DUA0572); Grey Fur Windjammer for 4071 (DUA0571); 8x Windscreens, Assorted Colors (DUA0570); Double Lock (Black) Miniature Clip (DMM0008); Miniature Double Pin (Black) (DMM0002-B); and Storage Case.

**DAK4071-E** (Mfr # DAK4071-E • B&H # DPDAK4071E): ENG/EFP Application Accessory Kit for Miniature Microphones.....**171.95**

**FKM4071 Film Microphone Kit**

This microphone kit is made for film or TV production when the mic needs to be invisible. The kit contains a 4071-BM miniature mic (pre-equalized for speech clarity) and various microphone concealment fixtures, specially designed to solve both hiding and clothing noise problems. The kit is delivered in a sturdy, hard case with a transparent lid leaving room for the specific connection adapter to close to any professional wireless system. Includes: Miniature Windjammer; Miniature Mesh Pop Filter; Miniature Double Pin (Black); Miniature Concealer; 10x Double-Sided Mic Tape; 10x Miniature Mic Tape; Storage Case

**FMK4071** (Mfr# FMK4071 • B&H# DPFMK4071) Film Microphone Kit.....**508.95**



## COS-11x

### Next-Generation Ultra-Miniature Lavalier Microphone

The successor to the popular COS-11s—the industry standard in ultra-miniature lavalier microphones, the COS-11x is designed to meet today’s HD audio standards while satisfying the concealment requirements of film, video and theater. The COS-11x features a new front mesh screen which is water resistant, better protecting the mic from perspiration and cosmetics. As a result, the COS-11x maintains superb frequency response in adverse recording conditions. In addition, the COS-11x is also water resistant making it ideal for outdoor shooting in foul weather.



- ◆ Sanken utilizes an original vertical placement of the diaphragm for a much greater effective area within an extremely small casing. Sanken’s unique, innovative designs have been emulated by other microphone manufacturers, but never matched in quality and performance.
- ◆ Using the unique “Vertical Diaphragm Layout” which provides superb sound from a microphone so small it is almost invisible, the COS-11x has perfect omni-directional polar patterns from 20Hz to 20kHz, and very natural sound from 50Hz to 20kHz. The frequency response is consciously adjusted to the human voice.
- ◆ Ideal for musical theater, TV news studio, ENG, TV/movie outdoor shooting and even live opera and pop recording.
- ◆ Available in three versions (and four colors each): COS-11x (48v phantom-powered), COS-11xBP (battery powered) and COS-11xPT (pigtailed, with no connector drivable from 3v to 10v DC.).
- ◆ A special pigtail version (COS-11xPT-RM) is also available with a “RED MARK” which is designed for close microphone setting and for loud voice, up to 136dB SPL.
- ◆ Soft and pliable cabling and clamp design assures long-term durability when the microphone is a pulled through clothing or hair.
- ◆ Each mic comes a horizontal clip, windscreens and rubber mount. A wide range of accessories allows easy positioning. There are also 11 colored windscreens to fit with any dress, jacket and hair.

<b>COS-11x:</b> With Pigtails in Black (Mfr # Mfr # COS-11XPT-BK • B&H # SACOS11XPTBKB).....	<b>314.00</b>
<b>COS-11x:</b> Phantom-powered only with TAF-5 connector in Black (Mfr # COS11XTA5BK • B&H # SACOS11XTA5B) .....	<b>324.95</b>
<b>COS-11x:</b> Battery-powered with 3-pin XLR connector in Black (Mfr # COS-11XBP • B&H # SACOS11XBPB).....	<b>399.00</b>

## COS-22

### Dual Capsule Lavalier Mic

Designed to meet the highest audio standards while satisfying the concealment requirements of film and video, the ultra-miniature COS-22 is only 1.25” but boasts a truly unique concept: dual high performance omni-mics in a tiny package. Utilizing the world’s most advanced precision craftsmanship for the ultimate in sensitivity, natural sound and hidden capabilities, the two-channel, dual omni-directional COS-22 is designed for high quality unobtrusive area miking, stereo recording of music and environmental ambience, redundant capsule live broadcast (e.g. news anchors), and boundary-style miking for film and television. In addition, the COS-22 can be used as a noise cancellation directional microphone pair by reversing the phase of one channel before summing the two outputs.



- ◆ Complete redundancy from capsule to connections.
- ◆ High output and low noise with extremely smooth omnidirectional pattern control over a wide frequency range.
- ◆ Poly-phenylene-sulfide diaphragm provides dramatically higher humidity & temperature stability, than other condenser lavaliers.
- ◆ Vertical diaphragm placement protects against moisture.
- ◆ Built-in 3-layer windscreen minimizes pops, sibilance and wind noise.
- ◆ Holder clip provides critical distance between microphone and clothing for avoidance of mechanical/surface noise.

<b>COS-22:</b> Double Capsule Omnidirectional Lavalier Mic in Gray with HC-22 holder clip. (Mfr # COS-22 • B&H # SACOS22).....	<b>649.00</b>
--	---------------

## K6 SYSTEM

### Modular Electret Condenser Microphone System

The K6 Series is a modular condenser microphone system of exceptionally high quality. Available with a wide variety of interchangeable modules for different polar patterns, and capsule sizes, the K6 System provides a flexible tool for all sound reinforcement work.

The modular design of the K6 power supply allows you to use different lavalier capsules for on air talent and live theater applications.



### K6/K6P Powering Modules

At the heart of the K6 series is the K6 power supply. The K6 is the backend of the multi-mike system and accommodates a balanced, low impedance 3-pin XLR output connector. The K6 Module supplies power to any capsule in the series. It can run for 150 hours on a single AA battery, or can be used with 12 to 48v phantom power (AA battery doesn't drain while phantom-powering). The K6 features an on/off switch with LED battery status indicator; and a bass roll-off switch which will compensate for proximity effect in close miking, or for wind rumble in field recording. The K6P phantom powering module provides an alternative to the K6 that is 42mm shorter and 15 grams lighter, while offering the same integrated bass roll-off switch. Ideal for fixed installations and applications where size is a factor and phantom power availability is not a concern.

### Omni-Directional Lavalier Capsules

#### MKE2-60 Gold

The industry-standard for TV and theatrical production, the MKE2-60 sub-miniature omni lavalier is unobtrusive and easy to conceal. Its accurate frequency response reproduces natural, uncolored sound. An extremely thin low mass diaphragm exhibits extraordinary transient response. The stranded, stainless-steel reinforced cable provides maximum tensile strength and low contact (clothing) noise. May also be used as a clip-on instrument mic.



#### MKE102-60

Similar in size to the MKE2-60 with several significant differences. The capsule head can easily be detached for use with straight or right angle cables. Highly immune to moisture, it is a natural for theater or outdoor productions. Frequency response is optimized for speech pickup with its 4 to 6 dB rise at 8kHz. Extremely low self-noise makes it ideal for broadcast as well.



#### MKE104-60

The MKE104-60 is the same as the MKE102-60 except it is a cardioid mic, which makes it ideal for applications that require isolation of the source. Use in live musical performances and for reporting when there are several announcers covering a scene with different audio feeds.

### K6 System (lavaliers for K6 do not include MZQ222 clip and MZW2 windscreen)

**K6** (SEMKE6): Powering module (powered by AA battery or phantom power). On/off switch with LED indicator and bass rolloff.....**Call**

**K6P** (SEMKE6P): K6 with phantom power only. No on/off switch.....**259.95**

**MKE2-60 Gold** (SEMKE260): Omnidirectional reduced sensitivity lavalier for K6, black with integrated K6 collar.....**289.95**

**MKE102-60** (SEMKE10260): Omnidirectional lavalier for K6 with right-angle cable. Includes a microphone capsule, windscreen, right-angle cable and black tie clip.....**304.95**

**MKE104-60** (SEMKE10460): Cardioid lavalier for K6 with right-angle cable. Includes a mic capsule, windscreen, right-angle cable to lavalier with K6 collar and a tie clip .....**304.95**

**MKE102S-60** (SEMKE102S60): Omnidirectional lavalier system. Includes a black microphone capsule, a windscreen, a straight cable with K6 collar and a tie clip .....**289.95**

**MKE104S-60** (SEMKE104S60): Cardioid lavalier system. Includes a black microphone capsule, a windscreen, a straight cable with K6 collar and a tie clip .....**289.95**

**MKE2-60/K6** (SEMKE260K6): Omnidirectional lavalier system with K6 power supply. Includes a black microphone, a K6 powering module, a dual-post tie clip and a carrying case ....**485.95**

**MKE102S/K6** (SEMKE102SK6): Omnidirectional lavalier system with K6. Includes a black microphone capsule, a straight cable with K6 collar, a tie clip, K6 and carrying case.....**565.50**

**MKE104S/K6** (SEMKE104SK6): Cardioid lavalier system with K6. Includes a black microphone capsule, a straight cable with K6 collar, a tie clip, K6 and a carrying case.....**512.95**

## Accessories for Lavalier Mics

### Windscreens for MKE2

#### Foam Windscreen

(Mfr # MZW2-F • B&H # SEMZW2F) .....**5.00**

#### Steel Mesh Grill and Windscreen

Black (Mfr # MZW2-A • B&H # SEMZW2A) .....**9.95**

Nickel (Mfr # MZW2-G • B&H # SEMZW2G) .....**16.50**

### Pin Clips for MKE102/104

A pin-style, lavalier clothing clip.

Black (Mfr # ZH100-ANT • B&H # SEZH100B) .....**12.50**

Grey (Mfr # ZH100-GR • B&H # SEZH100G) .....**12.50**

### Clips for Right Angle KA Cables

Black (Mfr # MZQ100-ANT • B&H # SEMZQ100B),

Beige (Mfr # MZQ100-BEI • B&H # SEMZQ100BE) and

Grey (Mfr # MZQ100-GR • B&H # SEMZQ100G) .....**6.95**

### Tie Clips

#### Single Bar Lavalier Tie Clip

For the ME102 and ME104.

(Mfr # TB-US • B&H # SETBUS) .....**5.50**

#### Dual Post Tie Clips

For MKE2/102/104. Available in

Black (Mfr # MZQ222 • B&H # SEMZQ222) and Nickel

(Mfr # MZQ222-NI • B&H # SEMZQ222NI) .....**19.95**

#### Double Tie Clip

For MKE2 (Mfr # MZQ22-A • B&H # SEMZQ22A) ....**24.95**

#### Magnetic Mount Set for the MKE 2

Lets you wear the wireless MKE 2 on T-shirts, sweaters, dresses, and other garments without piercing the cloth. The set has an inconspicuous white finish. (Mfr # MZM10/2 • B&H # SEMZM102)

### Steel Mesh Grills

#### Steel Mesh Grills for MKE-2

Provides adequate protection from shock and minimizes noise due to wind and proximity effect.

Black (Mfr # MZW2-A • B&H # SEMZW2A) and

Nickel (Mfr # MZW2-G • B&H # SEMZW2G) finish ..**16.50**

#### Steel Mesh Grille for MKE-102

Black (Mfr # MZW102-ANT • B&H # SEMZW102B) and

Nickel (Mfr # MZW102-NI • B&H # SEMZW102N) .....**16.50**

#### Steel Mesh Grille for MKE-104

Black (Mfr # MZW104-ANT • B&H # SEMZW104B) and

Nickel (Mfr # MZW104-NI • B&H # SEMZW104NI) ....**43.95**

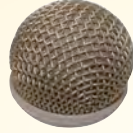

MZW2-G  
Nickel Mesh Grill



MZW2-F  
Foam Windscreen



TB-US  
Lavalier Tie Clip



ZH100  
Pin Clip



MZQ222  
Dual Post Tie Clip



MZW2-A  
Black Mesh Grill

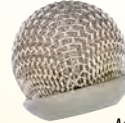

MZW102N  
Nickel Mesh Grill

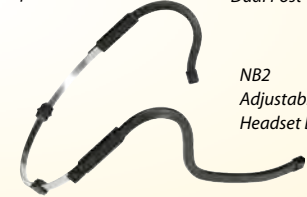

NB2  
Adjustable  
Headset Boom

#### Adjustable Headset Boom

A unique, flexible, adjustable headset that allows you to adapt any Sennheiser lavalier for use as a headworn mic. The unobtrusive, comfortable and rugged design fits any head. Available in Black (Mfr # NB2 • B&H # SENB2) or Beige (Mfr # NB2-BEI • B&H # SENB2BEI) .....**59.95**

#### Accessory Kit for MKE-2

This accessory kit includes a nickel and black dual post tie clip, a nickel and black windscreen, a black and grey pin clip, and a carrying case (Mfr # MZ2 • B&H # SEMZ2) .....**39.95**

#### MKE-102/104 Accessory Kit

This accessory kit includes a nickel and black dual post tie clip, a nickel and black windscreen, a black and grey pin clip, and a carrying case. (Mfr # MZ100 • B&H # SEMZ100) .....**64.95**

## Lavalier Accessory Kits

#### Lavalier Accessory Backup Kits

Only available at B&H, this Lavalier Accessory Backup Kit provides 3 spare windscreens and lavalier clip. Lavalier users know all too well how easily accessories are lost or broken during production, the kit provides a suitable backup in one low cost package.



To fit small lavalier mics measuring 1/8" (3mm) in diameter. (B&H # BHCSLBUKS) .....**13.45**

To fit medium-size lavalier mics measuring 1/4" (6 mm) in diameter. (B&H # BHCSLBUKM) .....**13.45**

To fit large lavalier mics measuring 3/8" (9.5mm) in diameter. (B&H # BHCSLBUKL) .....**13.45**



#### Deluxe Lavalier Accessory Kits

Only available at B&H, the Deluxe Lavalier Accessory Kit is the ideal solution for professional audio engineers in broadcast, electronic news gathering (ENG) and electronic field production (EFP). The kit delivers everything needed for successful results. Backup Kit to fit small lavalier Deluxe Lavalier Accessory Kit for small mics measuring 1/8" (3mm) in diameter.

For small-size lavalier mics measuring 1/8" (3 mm) in diameter. (B&H # BHDLAKS) .....**84.95**

For medium-size lavalier mics measuring 1/4" (6 mm) in diameter. (B&H # BHDLAKM) .....**84.95**

To fit large lavalier mics measuring 3/8" (9.5mm) in diameter. (B&H # BHDLAKL) .....**84.95**

## LAVALIER MIC ACCESSORIES

## Remote Audio Micro-Cat Windscreen

The Remote-Audio Micro-Cat Windscreen is a quality fuzzy outer layer wind diffuser plus two additional inner layers of open weave fabric made to fit snugly over lavalier microphones.

The windscreen makes the lavalier microphone suitable for outdoor recording occasions by protecting the capsule against noise from sudden and unwanted wind gusts.



## Micro-Cat Lavalier Windscreen



<b>White</b> (Mfr # HAMCATW • B&H # REMCATW) .....	<b>25.00</b>
<b>Tan</b> (Mfr # HAMCATT • B&H # REMCATT) .....	<b>25.00</b>
<b>Gray</b> (Mfr # HAMCATG • B&H # REMCATG) .....	<b>25.00</b>
<b>Black</b> (Mfr # HAMCATB • B&H # REMCATB) .....	<b>25.00</b>

## Rycote Lavalier Microphone Accessories

## Windjammer

This Rycote windjammer is designed for use with lavalier microphones worn on the outside of clothing. The furry windjammer includes removable foam inserts that secure the microphone and provide the air space needed for true wind diffusion. The windscreen that was included with your Lavalier microphone can be used as well. The windjammer is guaranteed to be the optimum solution for high wind environments.



(Single) - <b>Black</b> (Mfr # 065514 • B&H # RYWFLB) .....	<b>25.00</b>
(Pair) - <b>Black &amp; White</b> - B&H Kit (B&H # RYWFLPBW) .....	<b>50.00</b>
(Single) - <b>White</b> (Mfr # 065516 • B&H # RYWFLW) .....	<b>25.00</b>
(Pair) - <b>Gray</b> (Mfr # 065502 • B&H # RYWFLPGK) .....	<b>50.00</b>
(Single) - <b>Gray</b> (Mfr # 065515 • B&H # RYWFLG) .....	<b>25.00</b>
(Pair) - <b>White</b> (Mfr # 065503 • B&H # RYWFLPW) .....	<b>50.00</b>

## Stickies



The Rycote Stickies are double sided adhesive pads used for mounting lavalier microphones to clothing and skin. The adhesive is standard in the medical industry and offers a viable alternative to clips and pin mounts. The disposable pads are packaged in packs of 30.

(Mfr # 065506 • B&H # RYS) .....

## Undercover Pads

The Rycote Undercover pads are a disposable mount and windshield used for mounting lavalier microphones underneath clothing. There are 3 sheets of 10 pads (30 pads total) supplied in each package. The pads are double coated with a peel-off adhesive and a soft-woven material. The adhesive is peeled onto clothing, providing a tacky mounting surface for lavalier microphones. The woven fabric disc is placed over the microphone and adhesive surface, sandwiching the microphone and eliminating structure and rustling noise caused by movement of clothing, cables, etc.



(Mfr # 065102 • B&H # RYUCG) .....

## Overcover Pads

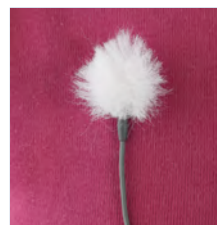

The Rycote Overcover pads are a disposable mounting and windshield solution for lavalier microphone use in gusty, outdoor environments. There are 3 sheets of 10 pads (30 pads total) supplied in each package. The pads are double coated with a peel-off adhesive and a soft-woven material.

The adhesive is peeled onto clothing, providing a tacky mounting surface for

lavalier microphones. The supplied fur disc is capable of suppressing noise caused by high wind gusts. The disc is placed over the microphone and adhesive surface, sandwiching the microphone and eliminating wind, structure and rustling noise.

(Mfr # 065505 • B&H # RYOC) .....

## LAVALIER MICS

## SM11

## Omnidirectional Dynamic Lavalier Mic

The SM11 is a miniature dynamic lavalier microphone designed for use in sound reinforcement and similar uses where a small, professional-quality, microphone is required. The SM11 has an omnidirectional pickup pattern, and its frequency response is optimized for lavalier use. The microphone is supplied with a tie clasp assembly, tie tack assembly, connector belt clip, and zippered carrying/storage bag.



- ◆ Frequency response optimized for lavalier use. Acoustically matches most stand- or desk-mounted microphones.
- ◆ Small and lightweight for unobtrusive, virtually unseen operation.
- ◆ Smooth exterior and recessed grille screen minimize clothing noise.
- ◆ Extremely flexible long-life cable.
- ◆ Two mounting options—tie clasp or tie tack.
- ◆ Convenient, secure belt clip attaches connector to belt or clothing.

**SM11 Lavalier Omnidirectional Dynamic Mic (SHSM11CN) .....99.95**

## MC50B

## Subminiature Omnidirectional Condenser Lavalier Microphone

A subminiature, electret condenser lavalier microphone, the omnidirectional MC50B provides uncompromised sound quality and high reliability with minimal visibility in applications such as television broadcasting and stage performances. Despite its small size, the microphone's condenser element provides full, clear and natural reproduction of speech. The MC50 omnidirectional model is supplied with two types of equalization caps for high frequency response shaping. The mild boost equalization cap attenuates the natural high frequency peak of the microphone. The high boost cap does not attenuate the high frequency peak.



Supplied mounting accessories include lapel clip, a tie clip, a pin mount, and a magnet mount, giving the user a wide variety of options for placement. Also includes two foam windscreens to minimize wind noise.

- ◆ Extended frequency response with user changeable equalization caps for response shaping (omni only).
- ◆ Low visibility with a variety of options for mounting.
- ◆ Low handling noise.
- ◆ Legendary Shure quality, ruggedness, and reliability.
- ◆ Includes In-line preamplifier and 5' cable with TA4F connector.

**MC50B - Sub-Mini Omni-Directional Lavalier Microphone with TA4F Connector for RPM626 Preamplifier (Black) (Mfr# MC50B • B&H# SHMC50B) .....289.95**

## SM93

## Miniature Omnidirectional Lavalier Mic

The SM93 is an economical subminiature lavalier condenser mic designed for use in speech applications. Despite its small size, the SM93 mic element provides full, clear sound comparable to much larger mics. Its smooth frequency response is specially tailored for chest-worn microphone operation, while controlled low-frequency rolloff reduces clothing and room noise. Runs on 11-52v DC phantom power.



- ◆ Designed for wired applications, it includes a preamp assembly with XLR connectors. The preamp can be pocketed, strapped to the body, or clipped to belt or waistband
- ◆ Supplied with small, inconspicuous mounting hardware. Includes a sew-on mounting bracket, a mounting block with attached tie bar, and an acoustic windscreen.

**SM93 Omnidirectional Lavalier Mic (SHSM93).....146.50**

## MX-183/184/185

## Lavalier Microphones

Three wired lavalier microphones no larger than a paper clip. Optional interchangeable mic cartridges allows you to tailor the mics to any audio environment. The mics attach to the supplied power supply with the Shure Tini Q-G connector. When the power supply is removed, they can be used with any Shure wireless transmitters.



- ◆ Interchangeable cartridges for omnidirectional, cardioid and super-cardioid polar patterns.
- ◆ Black, snap-fit foam windscreen. ◆ Frequency Response 60 - 20 kHz.
- ◆ Includes both a pivoting single and dual microphone tie clip.
- ◆ Available with belt-clip phantom power only preamp and MX1BP battery/phantom power preamp.
- ◆ Attached 4' cable with Tini Q-G connector.

**MX183** Omni-directional condenser lavalier, belt-clip preamp, rotatable tie clip, dual tie clip, snap-fit windscreen. (Mfr #MX183 ;B&H #SHMX183) .....**167.50**

**MX184** Super-cardioid version of above. (Mfr #MX184 ;B&H #SHMX184) ..**186.50**

**MX185** (SHMX185): Cardioid version of above.....**179.95**

**MX183BP** (SHMX183BP): Omni-directional condenser lavalier microphone with 4' attached cable, MX1BP preamplifier .....**179.95**

**MX184BP** (SHMX184BP): Super-cardioid version of above.....**194.95**

**MX185BP** (SHMX185BP): Cardioid version of above.....**192.50**

**ECM-44 / 55 / 66 / 77 / 88**

## Electret Condenser Lavalier Microphones

Sony's lavalier microphones are manufactured to meet the most demanding professional broadcast and recording requirements. They are designed to deliver the highest level of performance and reliability. There are five primary lavalier mics in the series, offering different sizes and applications. Additionally, they offer three big advantages over other systems.

**High Performance:** Sony's lavalier microphones are distinguished by their superior performance, as represented by the wide (20Hz~20kHz) frequency response of the top-of-the-line ECM-88. They will more than measure up to your expectations.

**Wide Selection:** The ECM-88 is an extremely miniature, omni-directional mic designed for quality-critical applications in broadcasting, theater, and field productions. While slightly bigger, the ECM-77B is also incredibly small and light. The uni-directional ECM-66B is designed for close-miking of musical instruments. The popular ECM-55B incorporates a 10.6mm omni-directional capsule for versatility, while the ECM-44B offers high performance at a lower cost.

**Reliability and Convenience:** Careful attention is paid to make the capsule immune to external noise and adverse ambient conditions. The cable is strengthened to achieve a high resistance to damage caused by over flexing.

**ECM-44B** Omni-directional Electret Condenser Mic (SOECM44B)

Delivering clean, bright, yet natural reproduction, the ECM-44B makes Sony's exceptional condenser mics available for budget conscious productions, and a variety of sound reinforcement requirements, such as lectures and demonstrations. With in-line battery for powering via 48v phantom power or a single AA battery (for over 5000 hours). Supplied with urethane windscreen and clip.....**194.95**

**ECM44BC** (SOECM44BC)  
With a Sony SMC9-4P 4-pin connector .....**99.95**

**ECM44BMP** (SOECM44BMP)  
With a 3-pole mini jack and stable lock mechanism .**109.95**

**ECM44BPT** (SOECM44BPT)  
With an unterminated cable for custom installations .....**108.95**

**ECM-55B** (SOECM55B)

## Omni-directional Electret Condenser Mic

The ECM-55B is suitable for news, interviews and stage dramas. Frequency response is a wide 30Hz to 18 kHz. Directivity is optimized to ensure uniform, dependable output, regardless of the direction of the sound source. The metal mesh windscreen effectively eliminates both wind noise outdoors and pop noise in close-up situations. Complete with in-line battery for 2-way powering (battery or 48v phantom power). Supplied with metal windscreen and metal holder clips .....**CALL**



	ECM-44B	ECM-55B	ECM-66B	ECM-77B	ECM-88
Frequency Response	40 - 15k Hz	30 - 18k Hz	70 - 14k Hz	40 - 20k Hz	20 - 20k Hz
Dynamic Range	≥90dB	98dB	≥101dB	≥90dB	≥99dB
Signal-to-Noise Ratio	≥62dB	66dB	≥62dB	≥64dB	≥68dB
Max Input SPL	122dB SPL	126dB SPL	130dB SPL	≥130dB SPL	125dB SPL
Battery Life	Approx. 5000 hrs.	Approx. 5000 hrs.	Approx. 300 hrs.	Approx. 5000 hrs.	
Output Impedance at 1kHz	250Ω	100Ω	100Ω	150Ω	100Ω

## ECM-44 / 55 / 66 / 77 / 88

**ECM-66B Uni-Directional Electret Condenser Mic** (SOECM66B)

When superb rejection of ambient sound is desired, the ECM-66B yields clean, natural reproduction of vocals or musical instruments while maintaining excellent isolation from the acoustic environment. This miniature microphone has a uni-directional polar pattern, carefully contoured for better control of feedback. The higher voltage supplied to the microphone by the built-in DC-to-DC converter complements the electret condenser design, resulting in excellent transient response and thus better tonal quality. Complete with in-line battery for 2-way powering (battery or 48v phantom power), and a battery on/off switch to save power. An LED shows battery condition when the power is turned on.

**ECM66B** (Mfr # ECM66B • B&H # SOECM66B).....**370.00**

**ECM-77B Omni-directional Condenser Microphone** (SOECM77B)

Only 1/4" x 1/2" and a mere 0.04 oz., the microscopic ECM-77B offers increased mechanical impedance using a metal vaporized, fine ceramic backplate to provide an exceptional 40Hz to 20kHz frequency response and to assure resistance to humidity and temperature extremes. Combined with advanced techniques for sealing the capsule and acoustic housing, the ECM-77B delivers sound that is audibly superior and more pleasing than other lavalier mics. Ideal for broadcasting and stage applications where the mic must be inconspicuous, it enables unobtrusive miking plus also minimizes glare. Even when hidden inside a costume, its frequency response is wide enough to pick up the voice with no perceptible change in quality, while minimizing the pick-up of rustling noise.

**ECM77B**  
(SOECM77B):.....**385.00**

**ECM77BMP** (SOECM77BMP): With a 3-pole mini jack and stable lock mechanism.....**248.95**

**ECM77BPT** (SOECM77BPT): Supplied without a connector (pigtail) .....**242.95**

**ECM-88B Omni-directional Condenser Microphone** (SOECM88B)

An extremely miniature, omni-directional electret-condenser microphone for quality-critical applications in broadcasting, theater, and field productions. It's dual-diaphragm mechanism achieves high-sensitivity, flat-and-wide frequency response and low noise characteristics. The diaphragm and back-plates are fixed vertically to the microphone capsule, reducing the mechanical noise caused by cable vibration and friction. Water-resistant architecture reduces the risk of water or perspiration entering the mic capsule. The mic capsule measures just 5/32 x 5/32 x 11/16" allowing for easy, natural-looking concealment in a stage costume. The ECM-88B includes a horizontal clip, a vertical clip, a double clip, a urethane windscreens and a Sony 4-pin connector (SMC9-4P) for use with the supplied DC-78 power-supply or with the optional WRT-8B/822B wireless bodypack transmitters.



**ECM88** (Mfr # ECM88B • B&H # SOECM88B)  
Includes the DC-78 power-supply..... **495.95**

**ECM88PT**  
Supplied without a connector (pigtail).  
Available in Black (SOECM88BPT) and Beige (SOECM88FPT) .....**334.95/279.95**

**DC Power Supply Unit** (SODC78)  
Designed for use with the ECM-88, the DC-78 is powered via an AA alkaline battery or an external DC (12-48v) power supply. It has an XLR output.....**84.95**

**ECM-88 Microphone Accessory Kit** (SOADKIT88B)  
Includes two types of microphone holders (double-pin and tie-clip), a holder adapter for dual-microphone operation, plus six urethane windscreens (red, yellow, green, blue, gray, and black).....**148.95**

**Tie Clips and Windscreens for Sony Lavalier Mics****Misc. 6-packs of Clips for the ECM-88B**

Safety Mic Clips (SOSADS88B).....**149.95**  
Dual Holder Adapter (SOSADW88B) .....**74.95**  
Horizontal/Vertical Tie Clip (SOSAD88B) ....**134.95**

**Horizontal Lavalier (Single) Tie Clips**

For the ECM-44B (SOSC44) ..... **16.95**  
For the ECM-44B (SOSADH44B): Set of 6.....**99.95**  
For the ECM-55B (SOSADH55B): Set of 6.....**99.95**  
For the ECM-77B (SOSC77) ..... **14.95**  
For the ECM-77B (SOSADH77B): Set of 6....**139.95**  
For the ECM-88 (SOSADH88B): Set of 10.....**159.95**

**Horizontal Lavalier (Double) Tie Clips**

For ECM-77B 6-pack (SOSADW77B) .....**119.95**  
For ECM-88 6-pack (SOSADW88BL).....**149.95**

**Vertical Lavalier (Single) Tie Clips**

For ECM-77B (SOSADV77B): Set of 10 .....**147.95**  
For ECM-88 (SOSADV88B): Set of 10 .....**159.95**

**Urethane Windscreens**

Black for ECM-44 (SOWS44) .....**11.95**  
Black for ECM-44 (SOADR44B): Set of 6 .....**99.95**  
Black for ECM-66 (SOADR66B): Set of 6 .....**99.95**  
Black for ECM-77 (SOWSU77S) .....**9.95**  
Black for ECM-77 (SOADC77B): Set of 12 .....**99.95**  
Color for ECM88 (SOADC88): Set of 6 .....**134.95**  
Black for ECM88 (SOADR88B): Set of 12.....**118.95**

**Metal Mesh Windscreens**

Black for ECM-77 (SOWSM77S) .....**19.95**  
Black for ECM-77 (SOADR77B): Set of 6 .....**94.95**

## TR50

### Miniature Professional Lavalier Microphone

When it was introduced, the TR50 miniature microphone revolutionized the industry—and since then it has become the standard in feature films and television production. In addition to its diminutive size and superior sound quality, the TR-50 offers a combination of features that are simply not offered by any other microphone. The TR50 answers the needs of even the most demanding sound recording engineer. It is designed with the latest electret development and electronics technology, to provide high sound quality with little or no visibility. Its small size and unique design permit a variety of uses and fastening options, that make it ideal for unobtrusive appearance and hidden mic use. The tiny omni-directional capsule features minimum sound coloration and is therefore easily combined with boom mics during post production. A variety of accessories makes mounting the mic on or under clothing easy, with reliable results.



#### FEATURES

- ◆ Extended frequency response range and omni-directional characteristics have been designed to satisfy the most stringent requirements in all professional audio fields, particularly film and TV production.
- ◆ The omni-directional polar pattern provides a generous pick up response at the direct and off-axis sections of the microphone capsule. The result is enhanced sensitivity and minimal noise associated with movement, wind and clothing contact
- ◆ Minimum sound coloration for universal use
- ◆ Features a hardwired in-line power supply that accepts +48V phantom power, and terminates with a 3-pin XLR male connector. Can also be powered via 1.5v silver oxide button battery (TR-BATT).
- ◆ Optional TR79 power supply allows direct attachment to dozens of wireless mic transmitters (see wireless mic section).

#### TR50 Omni-Directional Lavalier Condenser Microphone (available in four colors)

- White** (Mfr # TR50WPS • B&H # TRTR50WPS) ..... **314.95**  
**Black** (Mfr # TR50BPS • B&H # TRTR50BPS) ..... **314.95**  
**Tan** (Mfr # TR50TPS • B&H # TRTR50TPS) ..... **314.95**  
**Gray** (Mfr # TR50GPS • B&H # TRTR50GPS) ..... **314.95**

Each includes Cable Holder (CH), Clip On Holder (COH), Tie Bar (TB), Tie Tack (TT), Windscreen (WS), Tape Down (TD) and Carrying Case.

#### TR50 Accessories

**Foam Windscreen:** With plastic support, slips on easily to blend in for low-profile functionality. Available in Tan/Flesh (Mfr # TWS • B&H # TRTWS), Gray (Mfr # GWS • B&H # TRGWS), White (Mfr # WWS • B&H # TRWWS) ..... **13.95**

**Mic Cage 1:** Accessory clip with plain back positions the TR50 underneath clothing for optimum recording results, while remaining concealed. (Mfr # MC1 • B&H # TRMC1) ..... **17.95**



**Mic Cage 2:** Same as above, except with vampire pin back (Mfr # MC2 • B&H # TRMC2) ..... **21.95**



**Clip Tie Clip:** Available in Black (Mfr # BTT • B&H # TRBTT), Tan/Flesh (Mfr # TTT • B&H # TRTTT), White (Mfr # WTT • B&H # TRWTT) ..... **7.50**

**Tie Bar with Alligator Clip:** Available in Black (Mfr # BTB • B&H # TRBTB), Gray (Mfr # GTB • B&H # TRGTB), Tan/Flesh (Mfr # TTB • B&H # TRTTB), White (Mfr # WTB • B&H # TRWTB) ..... **7.50**



**Double Tie Bar:** Accommodate two TR50's. Ideal for stereo or secondary reference pick up. (Mfr # BDTB • B&H # TRBDTB) ..... **16.95**

**Clip Mic Holder with Vampire Pins:** Available in Black (Mfr # BCOH • B&H # TRBCOH), Gray (Mfr # GCOH • B&H # TRGCOH), Tan/Flesh (Mfr # TCOH • B&H # TRTCOH), White (Mfr # WCOH • B&H # TRWCOH) ..... **9.50**

**Cable Holder with Vampire Pins:** Available in Black (Mfr # BCH • B&H # TRBCH), Gray (Mfr # GCH • B&H # TRGCH), Tan/Flesh (Mfr # TCH • B&H # TRTCH), White (Mfr # WCH • B&H # TRWCH) ..... **6.95**

**Cable Reel:** Eliminates the clutter of excess cable and allows for neat storage. Available in Black (Mfr # BCR • B&H # TRBCR), Gray (Mfr # GCR • B&H # TRGCR), Tan/Flesh (Mfr # TCR • B&H # TRTCR), White (Mfr # WCR • B&H # TRWCR) ..... **7.50**

**Boundry Tape Down Holder-Black** (Mfr # BBLTD • B&H # TRBBLTD) ..... **9.95**

## VT500 • VT506

### Miniature Lavalier Microphones

The VT500 has extremely smooth omni-directional pattern control over a wide frequency range. It is designed for performing talent in broadcast, theater, film, public address and sound reinforcement among other applications. Speech clarity is enhanced by a slight frequency emphasis giving excellent voice reproduction while eliminating placement constraints. Due to the unique design of the VT500, noise transmission from handling and clothing movement is kept at a minimum. An integral filter provides efficient RF suppression. The cable is smooth, rugged, sweat proof and has excellent isolation from rubbing noise.



Otherwise the same, the VT506 is slightly peaked above 8kHz providing brilliance and preserving sibilance which insures enhanced intelligibility when the microphone is hidden under clothing. It is designed for performing talent in broadcast, theatre, film, public address and sound reinforcement. An integral filter provides highly efficient RF suppression. The cable is smooth, rugged, sweat proof and has excellent isolation from rubbing noise.

Unterminated (3-wire pigtail) version comes with waterproof VTO Box and four accessories (Alligator Clip, Pro Windscreen, Dracula Mount, Tie Tac Clip) or as budget set with a silver metal box and 3 accessories (Alligator Clip, Standard Windscreen, Tie Tac Clip). Hardwired versions terminating with XLR include special longer black box in place of VTO and four accessories (Alligator Clip, Pro Windscreen, Dracula Mount, Tie Tac Clip).

#### VT500 Black

- Unterminated with NO accessories.  
(Mfr # VT0011 • B&H # VOV0011) ..... **165.00**
- Unterminated with silver box and three accessories. (Mfr # VT0026 • B&H # VOV0026) .. **185.00**
- Unterminated with VTO Box and four accessories. (Mfr # VT0010 • B&H # VOV0010) .. **210.00**
- Hardwired (3-pin XLR) with 48v phantom power supply.  
(Mfr # VT0060 • B&H # VOV0060) ..... **295.00**
- Hardwired (3-pin XLR) with 9-52v phantom power supply or battery powered.  
(Mfr # VT0061 • B&H # VOV0061) ..... **319.00**

#### VT506 Black

- Unterminated with NO accessories.  
(Mfr # VT0034 • B&H # VOV0034) ..... **165.00**
- Unterminated with silver box and three accessories. (Mfr # VT0051 • B&H # VOV0051) .. **185.00**
- Unterminated with VTO Box and four accessories. (Mfr # VT0033 • B&H # VOV0033) .. **210.00**
- Hardwired (3-pin XLR) with 48v phantom power supply.  
(Mfr # VT0062 • B&H # VOV0062) ..... **295.00**
- Hardwired (3-pin XLR) with 9-52v phantom power supply or battery powered.  
(Mfr # VT0063 • B&H # VOV0063) ..... **319.00**

#### VT500 and VT506 in White

- VT500 (Mfr # VT0028 • B&H # VOV0028), VT506 (Mfr # VT0052 • B&H # VOV0052) unterminated with silver box and three accessories ..... **200.00**
- VT500 (Mfr # VT0021 • B&H # VOV0021), VT506 (Mfr # VT0040 • B&H # VOV0040) unterminated with VTO Box and four accessories ..... **225.00**
- VT500 (Mfr # VT0068 • B&H # VOV0068), VT506 (Mfr # VT0070 • B&H # VOV0070) hardwired (3-pin XLR) with 48v phantom power supply ..... **310.00**
- VT500 (Mfr # VT0069 • B&H # VOV0069), VT506 (Mfr # VT0071 • B&H # VOV0071), hardwired (3-pin XLR) with 9-52v phantom power supply or battery powered ..... **335.00**

#### VT500 and VT506 Optional/Replacement Accessories

- Alligator Clip Black (VOVT0200) .. **11.95**, White (VOVT0255), Beige (VOVT0251) ..... **15.95**
- Dracula Mount Black (VOVT0201) .. **14.95**, White (VOVT0256), Beige (VOVT0252) ..... **19.95**
- Tie Tac Clip Black (B&H # VOV0202) **9.95**, White (B&H # VOV0257), Beige (VOVT0253) ..... **12.95**
- Pro Windscreen Black (VOVT0205) **14.95**, White (VOVT0258), Beige (VOVT0254) ..... **17.95**
- Magnetic Cage Clip with Cord (VOVT0207) ..... **34.95**
- Rubber Body Mount (VOVT0259) ..... **8.95**    Leather Body Mount (VOVT0209) ..... **11.95**

#### VT500 and VT506 in Beige

- VT500 (Mfr # VT0027 • B&H # VOV0027), VT506 (Mfr # VT0053 • B&H # VOV0053) unterminated with silver box and three accessories .. **200.00**
- VT500 (Mfr # VT0016 • B&H # VOV0016), VT506 (Mfr # VT0045 • B&H # VOV0045) unterminated with VTO Box and four accessories ..... **225.00**
- VT500 (Mfr # VT0064 • B&H # VOV0064), VT506 (Mfr # VT0066 • B&H # VOV0066) hardwired (3-pin XLR) with 48v phantom power supply ..... **310.00**
- VT500 (Mfr # VT0065 • B&H # VOV0065), VT506 (Mfr # VT0067 • B&H # VOV0067), hardwired (3-pin XLR) with 9-52v phantom power supply or battery powered ..... **335.00**

## AT3031

### Small-Diaphragm Cardioid Condenser Microphone

Studio-quality, low-profile cardioid condenser mic, the AT3031 features a flat, extended frequency response, high maximum SPL and wide dynamic range. Delivering outstanding performance and versatility. Its low self-noise (16 dB SPL) is perfectly suited for the most sophisticated recording equipment. Low-mass diaphragm improves transient response, increases response bandwidth and reduces handling and mechanical noise transfer.

- ◆ High max SPL and wide dynamic range
- ◆ Lo-cut switch (80 Hz, 12 dB/octave) and 10 dB pad
- ◆ Cardioid polar pattern reduces pickup of sounds from the sides and rear, improving isolation of desired sound source.



- ◆ Low self-noise (16 dB SPL) makes it ideal for today's digital recording equipment.

## AT4041 Small-Diaphragm Cardioid Condenser Microphone



The AT4041 is a pressure-gradient condenser microphone with a uniform cardioid polar pattern that is ideal for professional recording and broadcast applications. Very similar to the AT4051a except for interchangeable capsules. The AT4041 features a transformerless output for low self-noise, high output and very high SPL handling capability (up to 145dB). The balanced output is direct-coupled, resulting in a clean signal even under high-output conditions.

- ◆ Integral high-pass filter provides easy switching from a flat frequency response to a low-end roll-off. In addition to preventing the pickup of low-frequency ambient noise (such as air-conditioning) the high-pass filter may also be used to compensate for proximity effect in close-miking situations.
- ◆ Use of the supplied foam windscreens further reduces wind and "popping" noise. Ruggedly built, the AT4041 is housed in a turned brass case, not thin-wall aluminum. The surface is painted black for low reflectivity. Compatible with any remote "phantom" or "simplex" power source supplying 48v DC.

<b>AT3031</b> - Small Cardioid Studio Condenser Microphone (Mfr# AT3031 • B&H# AUAT3031) .....	<b>169.00</b>
<b>AT4041</b> - Small Diaphragm Cardioid Condenser Instrument Microphone (Mfr# AT4041 • B&H# AUAT4041) .....	<b>279.00</b>

## AT4051A • AT4053A

### Small-Diaphragm Cardioid and Hypercardioid Condenser Microphones

The AT4051a and AT-4053a are transformerless phantom-powered condenser studio microphones engineered for professional recording and broadcast. They offer smooth, flat frequency response and a clean signal, even in high-output conditions. They also feature exceptionally low self-noise, high output and fast transient response. But what separates them from other mics, is that the head capsules may be easily removed, stored and replaced with an cardioid or hypercardioid capsule to meet the needs of the widest range of miking applications.

They handle very high sound pressure levels with ease. An integral 80Hz hi-pass filter provides easy switching from a flat frequency response to a low-end roll-off. The hi-pass position reduces mic sensitivity to "popping" in close vocal use and to handling noise. It also attenuates unwanted low-frequency ambient noise. Use of the supplied foam windscreens helps reduce wind and "popping" noise. Their housings are constructed of turned brass and plated in black chrome for durability and low reflectivity. They operate on 48v DC phantom power. A compartmentalized case accommodates the microphone, stand adapter, windscreens and two optional head capsules.



## Small-Diaphragm Condenser Mics

### AT4051a • AT4053a

- ◆ They handle high sound pressure levels with ease—up to 146 dB SPL while producing no greater than 1% T.H.D.
- ◆ Integral 80 Hz hi-pass filter provides easy switching from a flat frequency response to a low-end roll-off. The switch is recessed to prevent accidental activation.
- ◆ Included foam windscreen helps reduce wind and “popping” noise.
- ◆ Constructed of turned brass and plated in black chrome for low reflectivity.
- ◆ Requires remote “phantom” or “simplex” power source supplying 48 volts DC.
- ◆ DC biased condenser element design.
- ◆ Output impedance of 100 ohms and output shall be transformerless balanced.
- ◆ Length of 6.10” a diameter of 0.83” (21.0 mm), and a weight of 4.2 oz. (120g).
- ◆ A compartmentalized carrying case accommodates the mic, stand adapter, windscreen and two optional head capsules.

### MODULAR EXPANSION CAPABILITY

AT-40 series microphones consist of two modular sub assemblies which are threaded together: the AT4900a-48 handle containing the mic’s electronics, and either the AT4049a-EL (omnidirectional), AT4051a-EL (cardioid) or the AT4053a-EL (hypercardioid) condenser head capsules. The head capsules may be easily removed, stored and replaced with an optional cardioid or hypercardioid capsule to provide the widest range of miking capability.



The AT4051a-EL capsule provides the advantages of a smooth, wide-response cardioid pattern.

The AT4053a-EL hypercardioid element offers excellent side rejection for increased working distance, and a highly uniform polar pattern that virtually eliminates off-axis coloration.

**AT4051A** (Mfr# AT4051A • B&H# AUAT4051A)  
Cardioid Studio Condenser Capacitor  
Microphone.....**499.00**

**AT4053A** (Mfr# AT4053A • B&H# AUAT4053A)  
Hypercardioid Studio Condenser  
Microphone.....**499.00**

## NEUMANN KM184 • KM185



The KM184 (cardioid) and KM185 (hypercardioid) are compact miniature microphones designed for small budget studio applications. Their slender shape and the transmission characteristics make them ideal for a wide range of applications in radio and television. Available in either matte black or nickel finish, the mics come in a folding box with a windshield and two stand mounts that permit connection to the microphone body, or the XLR-connector.

The pressure gradient transducers KM 184 and KM 185 feature very smooth frequency responses not only for the 0° axis, but also for lateral (off-axis) sound incidence. In typical usage, there is no coloration of sound over a wide pickup angle. The KM 185 features attenuation of sound incidence from the side or rear of about 10 dB, with minimum sensitivity at an angle of 120°. The KM 184 has a gentle rise at about 9 kHz.

### KM 184

- ◆ For universal use, especially for recording situations when it is necessary to attenuate off-axis sound (mainly from the rear) from other nearby instruments.
- ◆ As XY and ORTF stereo pair.
- ◆ Announcer’s mic for broadcasting.
- ◆ Spot mic, overhead.

### KM 185

- ◆ Especially for recording situations when it is necessary to attenuate off-axis sound (lateral and rear) from other nearby instruments.
- ◆ As XY stereo pair.
- ◆ In situations that are susceptible to acoustic feedback.
- ◆ Recording of speech, as in TV, movie and video productions, PA systems.
- ◆ Produces especially warm and bass supporting sound for artists who perform in proximity effect range.

**KM184NI:** Cardioid Studio Condenser Miniature Microphone in Nickel finish (Mfr # KM 184 NI • B&H # NEKM184NI).....**849.00**  
**KM184MT:** Cardioid Studio Condenser Miniature Microphone in Black finish (Mfr # KM 184 MT • B&H # NEKM184MT) .....**849.00**  
**KM185NI:** Hyper-Cardioid Studio Condenser Miniature Microphone in Nickel finish (Mfr # KM 185 NI • B&H # NEKM185NI).....**899.00**  
**KM184MT:** Hyper-Cardioid Studio Condenser Miniature Microphone in Black finish (Mfr # KM 185 MT • B&H # NEKM185MT) .....**899.00**

## NT3

### Hypercardioid Studio Condenser Microphone

The stylish NT3 is a studio and location workhorse. With both 48v phantom and internal 9v battery operation, this mic is at home anywhere. Designed for studio, stage and location work, this versatile handheld or stand mounted microphone incorporates a true externally polarized condenser (hyper-cardioid polar response) transducer with an internal capsule shock mounting system, and an ultra-low noise electronic circuit that has a high immunity to RF interference.

- ◆ True condenser externally biased 3/4" capsule
  - ◆ Dual power operation
  - ◆ Transformerless output
  - ◆ Internal capsule shock mounting
  - ◆ High level of RF rejection
  - ◆ Audio-grade surface mount components
  - ◆ Full frequency response
  - ◆ Battery status indicator
  - ◆ Cast metal body with durable satin nickel finish
- (Mfr # NT3 • B&H # RONT3) .... **269.00**

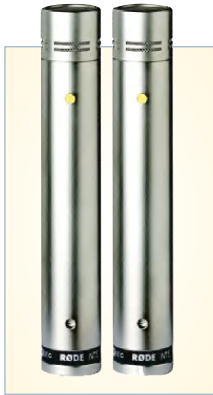

## NT5 Cardioid Studio Condenser Microphone

The NT5 is a cardioid condenser microphone offering a full frequency response and low-noise output circuitry. Designed for general instrument recording and sound reinforcement. The cardioid polar pattern effectively minimizes audio at the off-axis sections, reducing noise caused by leakage, monitors, additional instruments etc. The NT5 offers a frequency response of 20Hz to 20kHz allowing use in wide variety of applications. The NT5 is powered via +48, +24 volt phantom power. Available in single or pairs, they include windscreens and stand mounts in a durable road case.

- NT5 Single** (Mfr # NT5-S • B&H # RONT5S).....**219.00**  
**NT5 Pair** (Mfr # NT5 • B&H # RONT5) .....**429.00**

# SCHOEPS

## Colette Series Microphone Set

The Colette Series system is popular among professional field audio engineers. The modular CMC6 preamplifier and MK41 super-cardioid capsule provide a professional alternative to shotgun microphones when recording dialog indoors. The system is based on the modular CMC6 preamplifier and MK series capsules which are capable of wide, linear frequency response curves and superior audio quality. The system includes the CMC6 preamplifier, MK41 capsule, SG20 microphone mount, B5 pop-filter and case.

The CMC6 preamplifier features Class-A transformerless electronics, resulting in a very low noise floor and light weight. The high impedance input signal of the modular capsules are accurately converted to low-impedance energy, allowing for long cable runs without noise and radio frequency interference.

The MK41 capsule is a super-cardioid condenser capsule with a wide frequency range and high SPL handling. The super-cardioid capsule is effective in minimizing noise and ambient audio at the off-axis sections of the microphone capsule. The microphone system is more than suitable for crucial capturing of dialog and ambiance for film, professional video and professional audio applications.

**Colette Series Microphone Set:** Includes CMC6 Microphone Amplifier, MK41 Super-Cardioid Capsule, SG20 Microphone Mount, B5 Pop-Filter and Case.  
 (Mfr # CMC641SET • B&H # SCCMC641S) .....**1939.00**

**Colette Series Microphone Set:** Includes two CMC6 Microphone Amplifiers, 2 MK41 Super-Cardioid Capsules, two SG20 Microphone Mounts, two B5 Pop-Filters and Case.  
 (Mfr # CMC41ST • B&H # SCCMC641ST) .....**4073.00**

**Colette Series Microphone Set:** Includes two CMC6 Microphone Amplifiers, two MK4 Cardioid Capsules, two SG20 Microphone Mounts, two B5 Pop-Filters and Case.  
 (Mfr # CMC64ST • B&H # SCCMC64ST) .....**3625.00**



## ME-62 • ME-64

### Omni-Directional and Cardioid Capsules

The ME-62 is an omnidirectional microphone capsule used with the K6, or K6P powering modules for reporting, discussions and interviews. The ME-62 is particularly suitable for good reproduction of "room" ambience and "spaced omni" stereo recording. The ME-64 is a cardioid, shotgun, microphone capsule also used with the K6 and K6P powering modules. It has a very wide range of applications including reporting, interviews, dubbing, live sound reinforcement and recording applications. Both mics come in a matte black, anodized, scratch resistant finish.

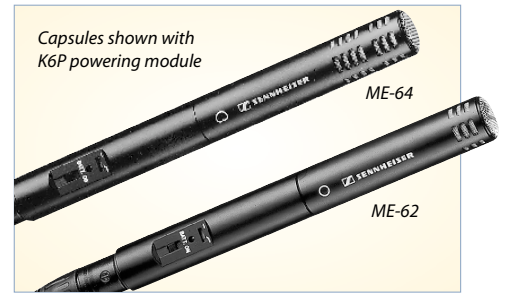

The ME-62 and ME-64 are powered by the K6 or K6P powering modules. They can run for 150 hours on a single AA battery, or can be used with 12 to 48v phantom power (AA battery doesn't drain while phantom-powering). The K6 features an on/off switch with LED battery status indicator; and a bass roll-off switch which will compensate for proximity effect in close miking, or for wind rumble in field recording. The K6P phantom powering (only) module provides an alternative to the K6 that is 42mm shorter and 15 grams lighter, while offering the same integrated bass roll-off switch. Ideal for fixed installations and applications on camera or on stage where size is a factor and phantom power availability is not a concern.

- ME-62** - Omni-Directional Capsule (Mfr# ME62 • B&H# SEME62) .....**149.95**
- ME-64** - Cardioid Microphone Capsule (Mfr# ME64 • B&H# SEME64) .....**179.50**
- K6P** Phantom Power Only Module (Mfr# K6P • B&H# SEK6P) .....**219.95**
- K6** Battery/Phantom Powering Module (Mfr# K6 • B&H# SEK6) .....**219.95**

## MKH-20 • MKH-30 • MKH-40 • MKH-50



### Small Diaphragm Condenser Microphones

MKH condenser mics represent the perfect fusion between exceptional sound and precision engineering, and have long been the choice in the most demanding broadcast applications. Their extremely transparent sound, high sensitivity, and excellent S/N ratio are perfectly complemented by their exceptionally low inherent self-noise, extremely low distortion, and unusually flat, linear frequency response. Their lightweight, durable, and weather-resistant construction makes them suitable for outdoor applications. Consisting of different pickup patterns, they are tonally consistent across the entire range because of their lack of coloration. In an MKH mic, the capsule is part of a tuned circuit in a radio frequency system. This makes all of them highly immune to humidity, and is responsible for their exceptionally low self-noise.

#### MKH-20 Omni-Directional

Low distortion push-pull element, transformerless RF condenser, flat frequency response, diffuse/near-field response switch (6 dB boost at 10 KHz), switchable 10dB pad to prevent overmodulation. Handles 142dB SPL with a high output level. Ideal for concert, Mid-Side (M-S), acoustic strings, brass and wind instrument recording.

**MKH-20** - Omni-directional (Mfr# MKH20-P48 • B&H# SEMKH20) .....**Call**

#### MKH-30 Figure-Eight

Symmetrical transducer design of the MKH-30 produces an unusually wide and smooth frequency response. Particularly suited to soloists and small instrumental groups, it can also serve as an 'S' or side microphone in MS stereo applications. As a support microphone it is particularly useful in the effective suppression of sounds from adjacent sound sources.

**MKH-30** - Bi-directional (Mfr# MKH30-P48 • B&H# SEMKH30).....**Call**

#### MKH-40 Cardioid

Low distortion push-pull element, transformerless RF condenser, high output level, transparent response, switchable proximity EQ (-4dB at 50Hz) and pre-attenuation of 10dB to prevent overmodulation. Achieves excellent results in vocal applications when used with a pop screen. Recommended for most situations, including digital recording and overdubbing vocals, mid-side (M-S) stereo, and conventional X-Y stereo.

**MKH-40** - Cardioid (Mfr# MKH40-P48 • B&H# SEMKH40) .....**Call**

#### MKH-50 Super-Cardioid

The MKH-50 offers a higher attenuation of side and rear sounds than the MKH-40. It is principally designed for use as a spot micr for applications requiring a high degree of side-borne sound muting and feedback rejection while maintaining the integrity of on- and off-axis sound fields.

**MKH-50** - Super-Cardioid (Mfr# MKH50-P48 • B&H# SEMKH50) .....**Call**

## Handheld Microphones

### AKG D230 Reporter's Microphone

A rugged dynamic microphone intended for use in ENG (electronic news gathering) activities in radio and television, the D230 incorporates a high output rare earth magnet structure designed to deliver exceptional sensitivity and clarity. Its response is tailored for maximum intelligibility of close-in speech, and its omnidirectional pattern is immune to proximity effects. The mic has an integral windscreen and is designed for very low handling noise. An internal hum compensation coil allows microphone use in environments where AC hum fields may be significant. Lightweight (only 8 oz.), the housing is made of an extremely rugged die cast metal and has a dark matte finish for minimum reflection or glare on television. The extended shaft allows for easy placement of station flags without typical handling problems.

Includes a stand adapter.

- ◆ Response tailored for close-in speech requirements for electronic news gathering (ENG)
- ◆ Omnidirectional pattern, with integral wind screen and very low handling noise
- ◆ High sensitivity (2.5 mV/Pa)
- ◆ Light-weight die cast metal body with dark matte finish
- ◆ Hum compensation

**D230** Reporter Microphone with Stand Adapter (Mfr # D230 • B&H # AKD230) .....**179.00**

**W23** Foam Windscreen (Mfr # W23 • B&H # AKW23) .....**28.20**



### Audio Technica AT8004

#### Omnidirectional Dynamic Microphone

The AT8004 (5.93" long) is an omnidirectional dynamic microphone designed for on-location interviews/sports broadcasting. It offers exceptionally clear and natural reproduction and features internal shock mounting that minimizes handling and cable noise. The microphone's omnidirectional polar pattern is ideal for reproduction of surrounding ambience. Its rugged housing with hardened-steel grille stands up to field use. Also available as the AT8004L (9.43" long) with an extended-length handle with room for a microphone flag.

- ◆ Ideal for interviews, sports broadcasting and as the "mono" mic used with a stereo microphone.
- ◆ Omnidirectional polar pattern provides natural reproduction.
- ◆ Rugged housing with hardened-steel grille stands up to field use.
- ◆ Internal shock mounting minimizes handling and cable noise.

**AT8004:** Includes a snap-in stand adapter with 5/8"-27 threads and a soft case (Mfr # AT8004 • B&H # AUAT8004) .....**CALL**

**AT8004L:** Includes a snap-in stand adapter with 5/8"-27 threads and a soft case (Mfr # AT8004L • B&H # AUAT8004L) .....**CALL**

### Beyerdynamic M58

#### Omnidirectional Dynamic Microphone

The M 58 is designed specifically for electric news gathering (ENG) and electronic field production (EFP) applications. Designed for interviews, its sophisticated internal shockmount dramatically reduces handling noise, while the mic's frequency response is tailored to provide broadcasters with a very accurate and intelligible sound. The M 58's weight-balanced design provides journalists with a high degree of comfort during lengthy interviews. Its rugged construction enables the mic to withstand physical and environmental punishment typically encountered during field production operations. Slim profile and non-reflective Nextel finish result in a low profile on camera. Includes WS-58 windscreen.

- ◆ High output moving coil transducer
- ◆ Internal shock mount reduces handling noise
- ◆ Extended frequency response with rising high-end for maximum intelligibility
- ◆ Rugged construction
- ◆ Non-glare, scratch-resistant finish
- ◆ Weight-balanced, slim-profile design

**M58:** Omni-Directional Handheld Dynamic ENG Microphone (Mfr # 403660 • B&H # BEM58) .....**239.020**



## Handheld Microphones

## COLES 4104B

## Noise Cancelling Commentator's Ribbon Microphone

The Coles 4104B Lip Microphone is a ribbon microphone designed for commentary and speech capturing in noisy environments. A sensitive ribbon transducer is combined with a directional polar pattern and flat, low-cut frequency response at 16Hz. The result is accurate signal reproduction without noise caused by ambiance or proximity effect.

In order to minimize noise and achieve the best frequency response, the Lip Microphone requires the user to position the microphone close to the mouth. A positioning bar makes contact with the users lip and creates the correct talking distance between the user and microphone. Stainless steel breath shields protect the capsule against moisture and noise due to sibilance and plosive sounds. A removable, plastic hygiene shield is available and can be cleaned for reuse or thrown away. The 4104B is designed for commentary applications in noisy, ambient environments. Directional polar and linear frequency response with low-cut roll off result in accurate reproduction with minimal noise.

**4104B Lip Microphone** with case (Mfr# 4104B • B&H# CO4104B).....**859.95**

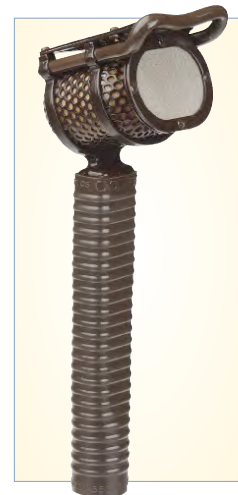

## ElectroVoice 635A

## Dynamic Omnidirectional ENG/EFP Microphone

Probably the most popular and well-known ENG/EFP microphone in the world, the 635A has survived being dropped, run over, thrown and even being shot while on location for film, TV and radio remotes. The 635A's uniform frequency response (80Hz-13kHz) is specially shaped for up-close vocals. Also available with a Neodymium element (635N/D-B).

## 635A • 635A/B

- ◆ Completely pop-free performance
- ◆ Four-stage pop and dust filter
- ◆ Internal effective shock absorber
- ◆ Includes stand adapter

**635A** (EL635A): Black finish .....**109.95**

**635A/B** (EL635AB): White finish .....**109.95**

## 635N/D-B

- ◆ N/DYM element offers higher output
- ◆ Uniform 80 Hz to 13kHz frequency response
- ◆ Integral windscreen and blast filter
- ◆ Acoustalloy diaphragm material for very smooth response over a wide frequency range

**635N/D-B** (EL635NDB): Black finish.....**129.95**

## RE50/B • RE50N/DB Omnidirectional Dynamic Microphones

These shock-isolated, omnidirectional, dynamic mics were created for the most exacting professional applications. Incorporating advanced shock-mounting techniques, they are designed particularly for hand-held broadcast and sound reinforcement use. Handling and clothing noise, even cord shock are isolated from the mic element so that mechanical induced noise is greatly reduced.

- ◆ No muddy lows when used near lips.
- ◆ Acoustalloy diaphragm material for very smooth response over a wide frequency range.
- ◆ Extremely low handling noise via Dyna-Damp "mic in-a-mic" shock mount system.
- ◆ Four-stage pop filter prevents dust and magnetic particles from reaching the diaphragm.
- ◆ Integral windscreen and blast filter provides excellent protection from wind noise, excessive sibilance, and "popping".
- ◆ Withstands high humidity, temperature extremes, and corrosive salt air.

**RE50/B**: Black finish with stand adapter, vinyl carrying pouch and hard shell case (Mfr #16501707 • B&H #ELRE50B).....**159.95**

**RE50N/DB**: Same as above with Neodymium capsule (Mfr #16502345 • B&H #ELRE50NB).....**179.95**



## MD46

### Handheld Cardioid ENG/EFP Microphone

A cardioid interview mic with studio quality, the MD46 focuses on the subject, increasing clarity. It has a traditional long handle, wind attenuation and off-axis rejection and is designed to possess an extended high-frequency response, warm lows, and a clean midrange. It also eliminates the tendency for a cardioid mic to emphasize plosives making them undesirable in the field. Sennheiser does this by putting a double layer in the sound inlet basket, enabling the MD 46 to highlight the desired sound. An optional windscreens is also available if needed.

- ◆ Rugged all metal body, integral microphone clamp thread, double layer grille basket, and long handle with excellent balance
- ◆ Low handling and wind noise, and the ability to eliminate vocal popping, make it the ideal interview mic for ENG work.
- ◆ Frequency response of 40Hz-18 kHz allows the MD46 to be used in a pinch as an announcer or guest mic in remotes, auxiliary studios or at interview turrets.



## MD42 Handheld Omni-Directional Microphone

The MD-42 is a rugged handheld reporter's microphone with omni-directional pick-up pattern optimized for rough use in live reporting and broadcasting environments. The MD 42 is a very 'good-natured' microphone whose design avoids wind and handling noise problems. Its omni-directional polar pattern ensures maximum intelligibility without having the microphone pointed directly at the talker. Comes in black with refined steel, black sound inlet basket.

- ◆ Durable metal housing and shock mounted capsule for maximum protection against the rigorous use on the road.
- ◆ Protective sound-inlet basket lines the metal capsule and protects against wind and pop noise.

<b>MD46</b> - Cardioid Handheld Dynamic ENG Microphone (Mfr# MD46 • B&H# SEMD46) .....	<b>194.95</b>
<b>MD42</b> - Omnidirectional ENG Handheld Microphone (Mfr# MD42 • B&H# SEMD42).....	<b>194.95</b>

## SONY F-112

### Handheld Omni-Directional Microphone

The F-112 is a high-quality, high performance, durable handheld dynamic microphone ideal for field production and news gathering application—especially for interviews.

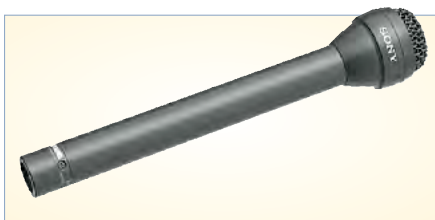

The F-112 is equipped with a omni-directional microphone capsule achieving highly sensitive and clear voice pick-up from all directions. Its robust metal body offers a high level of durability to withstand severe conditions even in the harshest of environments. In addition, the F-112 offers a well thought-out ergonomic design which provides a stable grip, as well as optimized balance – features essential for conducting smooth interviews. A robust brass connector is provided for repeating cable connections.

**F-112** (Mfr # F112 • B&H # SOF112)  
Omni-directional ENG Handheld Microphone.....**159.95**

## K-TEK

### Topper Windscreens for Handheld Microphones

The new Topper by K-Tek is a wind protection system designed specifically for handheld mics. Featuring an exterior of black fleece lined with tightly woven fabric, or with the traditional faux fur (black short hair) cover, tailored to fit snugly over standard foam covers. Great for popular microphones like the EV-RE-50 and Sennheiser MD46.



**K-TPR-FF** Topper – Faux Fur .051 lbs (23g).  
(Mfr# KTPRFF • B&H# KTTHH).....**48.95**

**K-TPR-FL** Topper – Fleecy .026 lbs (12g).  
(Mfr# KTPRFL • B&H# KTTHHF).....**49.95**

# Handheld Microphones

## VP64A/VP64AL Omnidirectional Dynamic Mic

High-output omnidirectional mics for professional audio and video production, the VP64A and VP64AL combine exceptional performance and comfortable feel with handsome on-camera appearance. Identical except for their handle lengths, the 7 7/8" long VP64A is ideal for close-up use and can be used outside as well as indoors. The longer VP64AL is well-suited to location interviews, sports broadcasting, and other situations where the 9 5/8" length is an advantage. Frequency response for both is 50 to 12,000 Hz.

- ◆ The omnidirectional pickup pattern provides uniform pickup on or off axis, eliminating the need for critical mic positioning.
- ◆ Tailored frequency response with mid-range presence rise adds crispness and clarity to speech.
- ◆ Neodymium magnet for increased output and maximized S/N ratio.
- ◆ Internal rubber isolation mount protects the microphone cartridge and minimizes handling noise.
- ◆ Water-resistant mesh grille allows use in adverse weather conditions.
- ◆ Supplied windscreen further reduces "pop" and wind noise.



<b>VP64A</b> Omni-Directional Handheld Dynamic ENG Microphone (Mfr# VP64A • B&H# SHVP64A) .....	<b>77.95</b>
<b>VP64AL</b> Omni-Directional Handheld Dynamic ENG Microphone with Extended Handle (Mfr# VP64AL • B&H# SHVP64AL) .....	<b>89.95</b>

## SM63 Omnidirectional Dynamic Mic

Elegant, yet rugged, the high output SM63 is designed for applications where performance and appearance are critical. Smooth, wide frequency response is tailored for optimum speech intelligibility. Controlled low-frequency rolloff reduces pickup of stand and wind noise. Virtually immune to strong hum fields such as those produced by studio lighting.

The champagne-finished SM63 is designed for hand-held use on stage and in broadcast, recording, and TV studios, while the champagne SM63L and black-finished SM63LB are for interviews, sports broadcasts, and other situations where longer microphones are desirable.

- ◆ Exceptionally rugged VERA-FLEX grille makes the mic impervious to dents, rust, corrosion, moisture and protects against damage from a drop of up to 6'.
- ◆ Patented shock mount system minimizes handling noise and stand vibration.
- ◆ Pop filter effectively reduces breath noise.
- ◆ Includes snap-in stand adapter and case.



The SM63L and SM63LB include a two-stage windscreen designed for outdoor use under adverse wind conditions.

<b>SM63</b> (Mfr# # SM63 • B&H# SHSM63) .....	<b>118.95</b>
<b>SM63L</b> Champagne finish (Mfr# # M63L • B&H# SHSM63L) .....	<b>132.95</b>
<b>SM63LB</b> Black finish (Mfr# # M63LB • B&H# SHSM63LB) .....	<b>132.95</b>

## MICROPHONE FLAGS

These blank microphone flags accept your graphics.  
They feature high-impact news grade construction and high-density foam inserts



<b>2" Black Square</b> (GBMFSSB) .....	<b>24.95</b>	<b>2.25" White Square</b> (GBMFMSW) .....	<b>24.95</b>
<b>2.25" Black Square</b> (GBMFMSB) .....	<b>24.95</b>	<b>2.5" White Square</b> (GBMFLSW) .....	<b>29.95</b>
<b>2.5" Black Square</b> (GBMFLSB) .....	<b>29.95</b>	<b>2.25 x 3.75" W. Triangle</b> (GBMFMTW) .....	<b>29.95</b>
<b>2x3" Black Triangle</b> (GBMFSTB) .....	<b>24.95</b>	<b>2.25" White Round</b> (GBMFMRW) .....	<b>26.95</b>
<b>2.25 x 3.75" Blk. Triangle</b> (GBMFMTB) .....	<b>29.95</b>	<b>2.5" White Round</b> (GBMFLRW) .....	<b>29.95</b>
<b>2.25" Black Round</b> (GBMFMRB) .....	<b>26.95</b>	<b>2.5" Blue Square</b> (GBMFLSBL) .....	<b>29.95</b>
<b>2.5" Black Round</b> (GBMFLRB) .....	<b>29.95</b>	<b>2.25 x 3.75" Blue Triangle</b> (GBMFMTBL) .....	<b>29.95</b>
<b>2" White Square</b> (GBMF2W) .....	<b>29.95</b>	<b>2.5" Blue Round</b> (GBMFLRBL) .....	<b>29.95</b>

## Accessories for Handheld Microphones

### Remote Audio

#### Fat-Cat

#### Universal Windscreen for Handheld Mics

The Fat-Cat is a wind diffuser designed for use with handheld, short boom, and ENG microphones. It features a fuzzy outer layer plus two additional inner layers of open-weave fabric that provides effective isolation from wind related noise. Perfect for the Electro-Voice RE-50, Shure VP-64, AKG D-230, and Beyers M-58.



**Fat-Cat** (B&H# REFATCAT) .....**68.00**

### Schulze-Brakel

#### Windscreens



8033

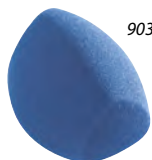

9033

High-quality handheld/ENG microphone windscreens made of open cellular reticulated foam. Available in blue and black and in three sizes: large (1 1/8" inside diameter), medium (1 1/8") and small (1"). Add your logo using standard iron-on transfers.

**8033 Square Large** (B&H # SC8033L), Medium (B&H # SC8033M) or Small (B&H # SC8033S) ...**41.95 Ea.**

**9033 Triangle Large** (B&H # SC9033L), Medium (B&H # SC9033M) or Small (B&H # SC9033S) ...**49.95 Ea.**

### Foam Mic Flags

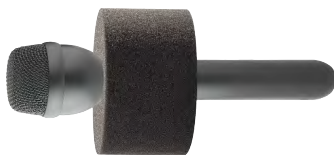

High-quality foam microphone ID flags available in three different shapes and various sizes. Available in 2 colors: black and blue. Add your logo using standard iron-on transfers.

4" x 2" triangle flag (B&H # SCTFR105).....**28.95**

4" x 1.8" triangle flag (B&H # SCTFR103) .....**28.95**

3.3" x 2" round flag (B&H # SCRF855).....**28.95**

3.3" x 2" square flag (B&H # SCSF855).....**28.95**

## Press Conferencing Equipment

### Whirlwind PressPower 2 Active Press Box

The press conference standard, the PressPower 2 features 2 mic/line inputs with individual gain controls and 16 transformer isolated outputs that are individually switchable for mic or line level operation. It includes a 20-segment LED level meter, an internal test tone generator, a built-in headphone monitor amp with volume control, high-pass filters, and phantom power — all conveniently front-panel accessible. The high-performance input stage provides clean audio even in high RF environments.

The PressPower 2 can be powered by 115/230v AC - 50/60Hz, via four 9v internal batteries or with an external DC supply (12-36v DC) connected via rear terminals. This allows it to be powered by a car battery, cigarette lighter, camera pack battery, etc. The unit will automatically switch to DC back-up power in the event of an AC power interruption.

Additional active mic/line outputs can be added with the optional 16 channel PRESS2XP Active Expansion Module. Using the expander module gives you up to 48 total active outputs. Additional mic outputs can be achieved by adding passive PB Series Press Boxes to outputs set to line level.

**PressPower 2 Active Pressbox - No Case** (Mfr # PRESSPOWER 2 NC • B&H # WHPP2NC) .....**1534.95**

**PressPower 2 Active Pressbox - with Case** (Mfr # PRESSPOWER 2 • B&H # WHPP2).....**1599.95**



### PressMite Active Press Box

This compact, active press feed distribution box distributes 12 high-quality mic level signals and 2 line level signals with a high degree of isolation between outputs. It provides a 60dB gain adjustment for one mic or line input. The PressMite also features a built-in headphone amp. Two 9v batteries provide power for over 8 hours of continuous operation, monitored by a Battery OK LED. The batteries are easily replaced via side-mount trays. A 120v AC/24v DC power adapter (PS24) is included.

In MIC input mode, 18v phantom power is selectable and a three segment LED headroom display speeds level adjustment. If more outputs are needed, PB Series Press Boxes can be connected to the line outputs to provide up to 48 additional mic outputs. Built to withstand the abuse of public events.

**PressMite - 1 Line In to 12 Mic/2 Line Out Active Press Box** (Mfr # PRESSMITE • B&H # WHPM).....**819.95**

### PB Series Passive Press Boxes

The PB Series expands mic outputs when used with line outs on PressPower 2 or PressMite active press boxes or any time a line level feed is available.

These passive units distribute one line level input to multiple mic level outputs. (Line level signal MUST be provided into these passive press boxes. A microphone directly into the input will not provide enough signal level for proper operation.) Each output is transformer isolated, provides excellent interchannel isolation and is ground lifted to help eliminate noise problems. Whirlwind TRSP-2F transformers are used throughout. The boxes are constructed with rugged, cold-rolled steel. Available with 6, 12, or 24 outputs.

**PB06: 6 Mic Out** (Mfr# PB06 • B&H# WHPB06) ..**289.95**

**PB12: 12 Mic Out** (Mfr# PB12 • B&H# WHPB12) ...**414.95**

**PB24: 1 Line In to 24 Mic Out Passive Press Box** (Mfr# PB24 • B&H# WHPB24) .....**748.50**



## Accessories for Handheld Microphones

### Press Conferencing Equipment



#### PSC Press Bridge

The Press Bridge is designed to allow audio distribution at press conferences. This 3-input, 12-output device provides

transformer-isolated audio feeds at microphone level. This Press Bridge features two mic level and one line level input, each with independent level controls, thus it may operate without the use of any additional audio mixer.

An important distinguishing feature of the Press Bridge is its ability to add additional "satellite style" output modules each with 12 additional outputs, all the way up to a total of 120 outputs. These freestanding output modules are available as the PSC "Press Train". Up to 10 Press Train modules may be remotely located from the main unit via standard microphone cables up to 500' in length thus eliminating multiple long cable runs to each member of the media.

The Press Bridge is housed in a heavy-duty aluminum case and finished in black powder coat for durability. It can be powered for more than 12 hours from two 9v batteries, or from a 9 to 18v DC adapter. A Sifam V.U. meter and a Internal tone oscillator are provided for level setting purposes.

**Press Bridge** Audio Distribution Center (Mfr# FPSC0014 • B&H# PSPB) .....1125.75

#### PSC Press Train

The Press Train is a 1-input, 12-output passive audio distribution box designed for press conferences. This ruggedly built device can be used in conjunction with the Press Bridge or with any professional balanced line level source. It accepts a standard +4dBm balanced line level signal and provides 12 transformer isolated mic level outputs. Custom wound, mu-metal-shielded transformer's high input impedance insure that up to 10 Press Trains can be connected to any professional 600 ohm balanced line without excessive line loading or distortion. Thus, you can obtain 120 separate, transformer-isolated, microphone-level outputs from a single line level source. In addition, the Press Train includes a high-quality Sifam V.U. meter for level setting and monitoring purposes.

The Press Train has one line level input and two line level loop-through connectors that are used to feed additional Press Trains. Up to 10 Press Trains may be connected in any daisy chain configuration without loss of sound quality. Interconnection of additional Press Trains is accomplished with standard microphone cables. Each of the Press Trains' 12 isolated mic level outputs have isolated grounds to eliminate ground loops.

**Press Train** Passive Press Box (Mfr# FPSC0015 • B&H# PSPTQ) .....470.25



### On-Stage Stands

#### MY-700



#### 6-Mic Pressbar (Black)

- ◆ Holds up to 6 microphones (7 with center mic stand thread)
- ◆ Cost-effective design for press conference applications
- ◆ Side bars are notched at 45 and 90 degrees in either direction
- ◆ Main bar- (4) 5/8"-27 male mounts
- ◆ Side bars- (1) 5/8"-27 male mounts

(Mfr # MY-700 • B&H # ONMY700) .....19.95

### Lenny's Media Stand



#### Press Conference Mic Holder

The Lenny's Media Stand is a multi-microphone holder designed to hold up to 17 microphones with flags for press conferences applications. It fits onto the top of any light stand, and no mic clips are required.

(Mfr# MEDIASTAND • B&H# LEMSQ) .....114.95

**2212-ABH** Air Cushioned Light Stand, 4 Sections, Black, 8'.

Mfr# # 2212ABH • B&H# IMLS8AQ).....34.95

### Mic-EZE Pig-E-Bak

#### Adjustable Dual-Mic Clamp

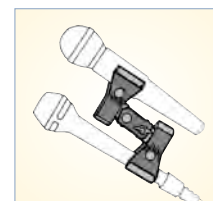

A double mic clamp that mounts microphones to microphones for dual feeds, and is fully adjustable to prevent phase cancellation. It provides a dual vertical in-line clamp set with a swing-type center attachment (black).

Dual-Mic Clamp (Mfr # PIGEBAK • B&H # MIPB) ..34.95

## AT875R

### Line + Gradient Shotgun Condenser Microphone



Designed for video production and broadcast (ENG/EFP) audio acquisition. AT's shortest shotgun microphone, it mounts conveniently on a DV camcorder without adding noticeable heft, and is ideal for use with compact digital cameras. This high-performance microphone offers a narrow acceptance angle of line + gradient design. It also features smooth, natural-sounding on-axis audio quality and excellent off-axis rejection of sound arriving from the sides and rear of mic.

- ◆ Designed for video production and broadcast (ENG/EFP) audio acquisition. Extremely short length (under 7") ideal for use with compact video cameras.
- ◆ Provides the narrow acceptance angle desirable for long-distance sound pickup. Excellent sound rejection from the sides and rear of mic. Tailored response minimizes camera and handling noise.
- ◆ Runs on 11-52v phantom power only

**AT875R Short Condenser Shotgun Mic:** Includes AT8405a stand clamp for 5/8"-27 threaded stands; 5/8"-27 to 3/8"-16 threaded adapter; windscreen; soft protective pouch. (Mfr # AT875R • B&H # AUAT875R) .....**199.95**

## AT897

### Line + Gradient Shotgun Condenser Microphone

The AT897 is designed for field audio acquisition in film/TV/video production, professional recording, wildlife recording and broadcast applications. It mounts conveniently on DV/HDV camcorders without adding noticeable heft, and remains out of the frame even with compact cameras. This high-performance short shotgun offers outstanding long-distance audio pickup due to narrow acceptance angle of line + gradient design. It also features smooth, natural-sounding on-axis audio quality and excellent off-axis rejection of sound arriving from the sides and rear of mic.

- ◆ Designed for video production and broadcast (ENG/EFP) audio acquisition. Short length (11") ensures mic stays out of the shot — even when used with compact digital cameras
- ◆ Smooth, natural-sounding on-axis audio quality. Provides the narrow acceptance angle desirable for long-distance sound pickup. Excellent sound rejection from the sides and rear of mic.
- ◆ Switchable low-frequency roll-off ◆ Operates on battery or phantom power

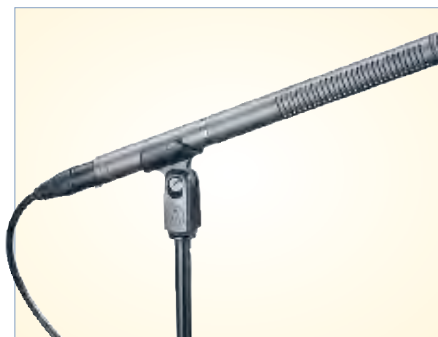

**AT897 Short Condenser Shotgun Mic:** Includes AT8405a stand clamp for 5/8"-27 threaded stands; AT8134 windscreen; battery; 5/8"-27 to 3/8"-16 threaded adapter; protective carrying case. (Mfr # AT897; B&H # AUAT897) .....**269.95**

Element	AT875R	AT897
	Condenser	
Polar Pattern	Line + Gradient	
Frequency Response (AT815B / AT835B)	90-20k Hz	20-20k Hz
Open Circuit Sensitivity <sup>1</sup> (Phantom/Batt)	-30dB (31.65mV)	-40dB (11.2mV)
Impedance (Phantom/Batt)	100 Ω	200 Ω
Maximum SPL Input <sup>2</sup> (Phantom/Batt)	127 dB	115 dB
Signal to Noise Ratio <sup>3</sup>	74 dB	77 dB
Dynamic Range-Typical <sup>4</sup> (Phantom/Batt)	107 dB	112 dB
Phantom Power (2.0mA Typical)	11 - 52V	
Battery Type (Life)	1.5v AA (up to 1200 hrs.)	
Low-Frequency Roll-off	12dB/oct @ 80 Hz	

1. re 1V @ 1 Pa    2. 1 kHz at 1% T.H.D.    3. 1 kHz @ 1 Pa    4. 1 kHz @ Max SPL

### AT897 Shotgun Microphone Kits

#### AT897 - Shotgun Microphone Kit with Mini Cable:

Includes: AT897, Rode SM3 Universal Shock Mount and XLR to Mini Impedance Matching Cable. (B&H # AUAT897K2) .....**269.95**

#### AT897 - Shotgun Microphone Kit with XLR Cable:

Includes: AT-897, Rode SM3 Universal Shock Mount and 1.5' XLR Right Angle Cable. (B&H # AUAT897K) .....**269.95**

#### AT-897 - Shotgun Microphone Basic Kit:

Includes: AT897, Rode SM3 Universal Shock Mount, Rycote 14cm Medium Hole Softie, K-Tek KE89CC Aluminum Boompole with Coiled Cable, Universal Hand grip, 1.5' and 20' Right Angled XLR Cables. (Mfr # AT897BK • B&H # AUAT897BK) .....**599.95**

## Shotgun Mics



### AT8015 • AT8035 Line + Gradient Condenser Mics

The 18" AT8015 and 14.5" AT8035 wide-range condenser mics with line + gradient polar patterns provide the narrow acceptance angle desirable for long distance sound pickup. They are ideal for use in professional recording, broadcasting, film/ TV/video production, high-quality sound reinforcement and other demanding applications requiring excellent sound rejection from the sides and rear. The shorter AT8035 is well suited for boom/fishpole use as well as mounting on professional video cameras, whereas the longer AT8015 has a narrower acceptance angle and is particularly useful for applications that require a longer reach.

	AT-815b	AT835b
Element	Condenser	
Polar Pattern	Line + Gradient	
Frequency Response (AT815B / AT835B)	30-20k Hz	40-20k Hz
Open Circuit Sensitivity <sup>1</sup> (Phantom/Batt)	-38dB (12.5mV)	-39dB (11.2mV)
Impedance (Phantom/Batt)	500 Ω	600 Ω
Maximum SPL Input <sup>2</sup> (Phantom/Batt)	131 dB	115 dB
Signal to Noise Ratio <sup>3</sup>	70 dB	
Dynamic Range-Typical <sup>4</sup> (Phantom/Batt)	106 dB	106 dB
Phantom Power (2.0mA Typical)	9 - 52V	
Battery Type (Life)	1.5v AA (up to 1200 hrs.)	
Low-Frequency Roll-off	12dB/oct @ 80 Hz	

- ◆ Rugged housing with a low-reflectance matte satin nickel finish.
- ◆ Excellent sound rejection from the sides and rear of mic.
- ◆ Recessed switch lets you choose either flat or a bass roll-off of 80 Hz at 12dB/octave.
- ◆ Powered by a single AA battery or 9-52v DC phantom power.
- ◆ Includes AA battery, foam wind-screen, mic stand adapter with 5/8"-27 threads, and a compartment carrying case designed to hold the microphone and accessories.

### BP4027 • BP4029 Stereo Condenser Shotgun Microphones

The 15" BP4027 and 9" BP4029 combine professional audio quality, outstanding versatility and robust construction, making them essential for today's high-quality stereo video production. Both feature independent line-cardioid and figure-of-eight elements configured in an M-S (Mid-Side) arrangement with switch-selectable internal matrixing. These innovative mics offer a choice of selecting a L/R stereo output (wide or narrow) via their internal matrixing system or choosing discreet M-Signals for later manipulation, a flexibility not available from any other manufacturer.



- ◆ Two internally-matrixed left/right stereo modes and non-matrixed M-S mode are switch selectable
- ◆ Switchable low-frequency roll-off
- ◆ Compact, lightweight design provides exceptional mounting versatility including camera-mount
- ◆ Include foam wind-screen, microphone stand adapter with 5/8"-27 threads, and compartment carrying case

	AT-815ST	AT835ST
Element	Condenser	
Polar Pattern	Line -Cardioid & Figure of 8	
Frequency Response (AT815B / AT835B)	30-20k Hz	40-20k Hz
Open Circuit Sensitivity (Mid/Side/LR Stereo)	-30dB (31.6mV) / -34dB (19.9mV) / -36dB (15.8mV)	
Impedance	200 Ω	200 Ω
Maximum SPL Input <sup>2</sup> (Mid/Side/LR Stereo)	123dB / 127dB / 126dB	
Signal to Noise Ratio <sup>3</sup> (Mid/Side/LR Stereo)	72dB / 68dB / 70dB	
Dynamic Range-Typical <sup>4</sup> (Mid/Side/LR Stereo)	101dB / 101dB / 102dB	
Phantom Power (4mA Typical at 48v)	11 - 52v	11 - 52v
Low-Frequency Roll-off	12dB/oct @ 80 Hz	

#### THREE STEREO MODES

**M-S mode** provides an independent cardioid element (Mid) and figure-8 element (Side). The advantage of this design is that the stereo balance of the separate Mid-Side signals can be adjusted later on in post-production instead of in the field.

**Two internally-matrixed modes** provide traditional "left-right" stereo that accommodates varying acoustic environments. The LR-W pattern is wider, allowing increased ambient pickup, while the LR-N pattern is more narrow to offer greater rejection with less ambience.

## AT-4071a / AT-4073a

### Line + Gradient Condenser Microphones



The AT4071a and AT4073a are transformerless line + gradient condenser microphones designed to meet the critical long-distance pickup demands of broadcasting, film/TV sound, professional recording and theater sound reinforcement. They feature a broad-band, linear on-axis frequency response, with maximum rejection of sounds from their sides and the rear. Rear polar lobing, common in shotgun microphones is greatly reduced and their off-axis response remains highly uniform. The resulting lack of sound coloration on- and off-axis makes them particularly suited for miking dynamic action in film/TV audio as well as in "spot" miking techniques in the music studio or theater.

◆ The effective working distance of a directional mic is determined in great part by its polar pattern and the uniformity of its off-axis response. However, the S/N ratio also affects the usable miking distance. The distance may be less if the system S/N ratio is low because of low mic sensitivity or noisy electronics. The AT4071a and AT4073a provide extremely high output and a noise floor that is hardly measurable, much less audible. Use them with confidence in distant miking applications and even under the stringent demands of modern digital recording systems.

- ◆ They set new standards in small size and light weight. Overall length is 9.13" (AT4073a) and 15.55" (AT4071a) and at 4 and 5.5 oz. respectively, they add practically no noticeable weight to the end of a fish pole or the top of a minicam.
- ◆ Through the use of an advanced design, both the diaphragm and the side ports are exposed to the same acoustic environment. One result of this is that they are less sensitive to noise caused by wind turbulence or the "encounter" noise of panning action. And there is a marked reduction in proximity effect. Recordings made at varying distances remain more consistent in response, making both production and editing quicker, easier and less costly.
- ◆ They are exceptionally resistant to mechanical or handling noise. An integral 150 Hz hi-pass filter is available to "roll-off" the low-frequency response, thereby attenuating unwanted low-frequency ambient noise (such as air conditioning). The switch is recessed to prevent accidental activation. Built to withstand rigorous use in the field, they are powered with any remote "phantom" or "simplex" power source supplying from 11 to 52v DC.

**AT4071a** Line/Gradient Shotgun Condenser Capacitor Microphone (Mfr# AT4071A • B&H# AUAT4071A) .....**659.95**  
**AT4073a** Line/Gradient Shotgun Condenser Capacitor Microphone (Mfr# AT4073A • B&H# AUAT4073A) .....**549.95**

## AT-4073

### Shotgun Microphone Kits

#### AT4073 Line/Gradient Condenser Shotgun Mic Kit:

Includes AT4073 Shotgun Microphone, Rode SM3 On-Camera Shock Mount, 1.5' Right Angled XLR Cable, AT8405 Snap-in Clamp, Foam Windscreen and Protective Case.

(B&H # AUAT4073AK) .....**569.95**

#### AT4073 Deluxe Shotgun Mic Kit:

Includes AT-4073a Shotgun Microphone, Rode SM3 On-Camera Shock Mount, Rycote 12cm Medium Hole Camera Mounted Softie, K-Tek KE-100CC Avalon 5-Section Graphite Fiber Cabled Boom Pole, Impact Universal Mic Hand Grip, 20' and 18" Right Angled XLR cables and Impact neoprene boompole bag.

(B&H # AUAT4073ADK) .....**1149.95**



AT4073 Deluxe Shotgun Mic Kit

## Shotgun Microphones

### SGM-1X Super-Cardioid Shotgun Condenser Microphone

The SGM-1X Professional Shotgun Microphone provides quality audio for the videographer. It is ideal for today's smaller, digital video cameras where longer models would appear in the frame when camera mounted. The hyper-directional super-cardioid shotgun microphone has a wide frequency response, exhibits low noise and accepts up to 110dB SPL input levels. The 11.8" long microphone uses a single "AAA" battery that will last over 1000 hours due to the mic's extremely low current drain. The low-impedance, XLR connected SGM-1X ships complete with a windscreen and Azden's proprietary shock-mount holder that isolates camera motor noise from the mic. The holder has provisions for both camera-shoe and mic-stand mounting.



**SGM-1X Super-Cardioid Shotgun Condenser Microphone**  
(Mfr# SGM-1X • B&H# AZSGM1X) ..... **149.95**

### SGM-2X Super-Cardioid Shotgun Condenser Camera Mountable Microphone

The SGM-2X Professional Shotgun Microphone System is designed for both the Pro-Sound and Broadcast markets. The microphone comes with two barrels making it either an omni (8.11" long) or, by adding the extension barrel, a supercardioid (15.75" long). Either configuration provides a sensitive, low-noise, wide bandwidth signal through its' balanced, low-impedanced XLR output. The SGM-2X comes complete with a unique, integrated shock-mount with both camera shoe-mount and mic stand-mount and two foam windscreens. The microphone is powered by a single, not included, "AAA" battery (no Phantom Power), which lasts more than 250 hours.



**SGM-2X Super-Cardioid Shotgun Condenser Camera Mountable Microphone** (Mfr# SGM-2X • B&H# AZSGM2X) ..... **219.95**



### SGM-1000 Super-Cardioid Shotgun Microphone

The Phantom-Powered Azden SGM-1000 comes with a windscreen and Azden's unique shockmount holder with integrated shoe-mount. Designed for Video and Audio Professionals, the SGM-1000 is a highly directional shotgun microphone with a wide frequency response and low noise levels. The SGM-1000 can be powered by external phantom power or a single AA battery.

**SGM-1X Super-Cardioid Shotgun Microphone** (Mfr # SGM-1000 • B&H # AZSGM1000)..... **299.95**

## DPA

### 4017 Professional Short Shotgun Mic

The DPA 4017 is a short and exceptionally lightweight shotgun microphone, offering a very directional pickup pattern with the typical natural DPA clarity maintained. It has been designed for a broad range of uses, from camera systems to fixed positions at sports facilities and for booming in ENG, broadcast, and film applications. Suppressing unwanted surrounding components to the signal, the 4017 is the state-of-the-art shotgun microphone with a smooth off-axis sound and large dynamic range. At just 210 mm (8.3") in length and 71 grams (2.5 ounces) in weight, the DPA 4017 is compact in size and among the lightest boom microphones available. Extensive research and development has been undertaken to optimize the sound coming from the sides and from behind. Minimizing the often very un-linear response of a shotgun microphone due to its side lobes is one of the key objectives of the 4017. The condenser capsule uses a high voltage pre-polarized back plate, giving the DPA 4017 high output as well as low noise and low distortion.

DPA 4017 features two switching filters incorporated in a brand new switching ring design: High boost +4dB at 8kHz and first order bass roll-off below 300Hz. A permanent third order high pass filter at 50 Hz removes unwanted low frequency disturbance from handling and wind noise. Due to its remarkable clarity, wide dynamic range, and excellent rejection characteristics, the DPA 4017 is equally at home in the recording studio and when used for sound reinforcement and live music miking.



(Mfr # 4017 • B&H# DP4017).... **1999.00**

## KMR 81i / KMR 82i

### Shotgun Microphones

The KMR 81i and KMR 82i are shotgun microphones with a high directivity that remains within the acceptance angle independent of the frequency.

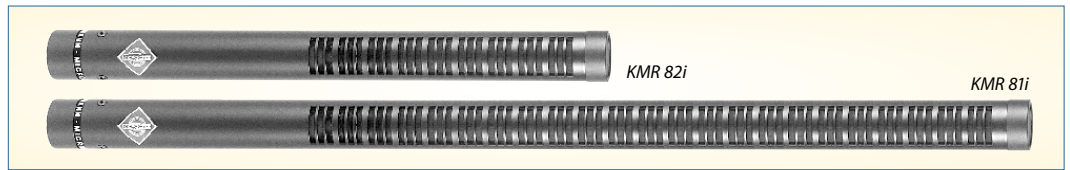

The advantage is that a sound source, for example an actor on stage, will not change its apparent tonal balance when moving within this area. Shotgun microphones are particularly useful in recording situations where a microphone cannot be positioned within the desired distance of the sound source to produce a sufficiently loud signal level.

Typical applications are film and video recordings, where the microphone should not appear in the picture. The KMR 82i is very often used on stage. The KMR 81i has been specifically designed for electronic news gathering.

### FEATURES

#### Acoustic Features

- ◆ These mics use a combination of a pressure gradient transducer and an interference tube. If the wavelength of the frequency is longer than the tube length, the mics work as pressure gradient transducers. At higher frequencies they operate as interference transducers for lateral sound.
- ◆ Off-axis sound sources are picked up with reduced level, but without coloration. Therefore, the microphones are well suited to record individual instruments of an orchestra. The pickup areas of several shotgun microphones may even overlap, like during recordings on a large stage, without causing any problem.
- ◆ They are less sensitive to wind and pop noise when compared to other mics with similar high directivity. The KMR 81i/82i both feature extremely low self noise, good impulse response, and high output level.

#### Polar Pattern

- ◆ These mics have a very directional characteristic. Their mic capsule is positioned inside a housing tube that is acoustically open but has a high flow resistance. The directional patterns of the mics are lobe shaped. The attenuation of lateral sound is practically independent of the frequency. The KMR 82i has a frequency independent directivity within a pickup angle of 45° for audio signals that determine the tonal balance of the program material. For the KMR 81i, this angle is 90°.

#### Filter and Attenuation (KMR 81i)

The microphone has a 10dB attenuation switch to prevent the input of the following unit from overloading. A second switch activates a 200Hz high-pass filter. Toward the lower frequencies the sensitivity of the microphone is attenuated by approximately 15dB at 50Hz. The frequency range above 200Hz is unaffected.

#### Using on Location

The shotgun microphones feature very high output capability and a remarkably low self-noise level. Their low power consumption, light weight, and low sensitivity to wind and handling noise, make them ideal tools for news gathering on location. Small dimensions, together with a balanced center of gravity, make handling easy without any whiplash effect. However, when on location and during strong wind conditions, it is recommended you use the using an additional wind screen (included). The wind screen is made of polyurethane foam and also serves as soft padding of the microphone in its leather carrying case. For mobile use a handle and an elastic suspension are available. An active handle with a built-in battery power supply makes an external phantom supply unnecessary.

#### Filter KMR (82i)

Between 2kHz and 15kHz the KMR 82i has a boost to compensate for HF transmission losses in air when recording distant sound sources. This may overemphasize any sibilance if the mic is used close-up. Therefore, a two-position slide switch allows you to select the setting that is best for balanced upper frequencies. The KMR 82i has a high-pass filter to suppress subsonic interference. The cutoff frequency may be raised to 120Hz (-3dB) with a built-in two-position slide switch.

	KMR 81i	KMR 82i
Acoustical Operating Principle	Interference transd.	Interference transd.
Directional Pattern	Supercardioid /lobe	Supercardioid /lobe
Frequency Response	20-20k Hz	20-20k Hz
Sensitivity	-18mV/Pa	21 mV/Pa
Impedance	150 Ω	150 Ω

**KMR81i**MT Black Finish (B&H # NEKMR81iMT), **KMR81i** Nickel Finish (B&H # NEKMR81i)..... **1399.00**  
**KMR82i**MT Black Finish (B&H # NEKMR82iMT), **KMR82i** Nickel Finish (B&H # B&H # NEKMR82i) ..... **1599.00**

## NTG-1

## Directional Condenser Microphone

The NTG-1 is a lightweight condenser shotgun microphone designed for film, video, television, voice-over and ENG applications. Super-cardioid polar pattern and line plus gradient acoustic principle effectively minimize audio and noise at the off-axis (sides) of the microphone, while the front of the capsule accurately reproduces incoming audio signal. The result is greater intelligibility and S/N ratio while using the NTG-1 in noisy environments. Its also designed to reduce noise caused by handling, rigid mounting hardware, loose cabling, etc.

The NTG-1 offers wide bandwidth and a controlled polar response coupled with low noise SMT electronics. Powered by an external +48v phantom power source with an XLR male output, the NTG-1 features a rugged, all metal, lightweight enclosure that is ideal for camera mounting yet durable enough to withstand the rigors of heavy road use. Ideal for mounting directly to video cameras with optional accessories or to a Boompole. Supplied windshield effectively suppresses wind noise when recording outdoors in moderate conditions.

**NTG-1:** Condenser Shotgun Mic with stand mount, zip pouch and windshield (Mfr # NTG-1 • B&H # RONTG1) .....**249.00**

**NTG-1 Basic Mic Kit:** Includes NTG-1, SM3 Shock Mount and 1.5' Right Angled XLR Cable (B&H # RONTG1K) ..... **249.95**

**NTG-1 Deluxe Mic Kit:** Includes NTG-1 Shotgun Mic, Rode SM-3 Shock Mount, Rycote 14cm Medium Hole Softie, K-Tek KE89CC Aluminum Boompole with coiled cable, 1.5' and 20' right angles XLR cables, Universal Hand Grip and Neoprene Boompole Bag (B&H # RONTG1BK) ..... **559.95**



## NTG-2 X-Long Directional Condenser Microphone

The NTG-2 is a lightweight (only 5 oz.) condenser shotgun microphone specifically designed for film, video, television and production.

The NTG-2 provides a balanced low impedance output stage and operates either from an internal AA battery or 48v phantom power. Wide bandwidth and controlled polar response coupled with low noise SMT electronics, makes the NTG-2 the perfect choice for film, video engineering and voice-over work. The NTG-2 is extremely lightweight so it can be mounted directly to video cameras or on boom poles. Includes windshield to effectively suppress wind noise when recording outdoors in moderate conditions.

**NTG-2:** Condenser Shotgun Mic with mount and windshield (Mfr # NTG-2 • B&H # RONTG2) .....**269.00**

**NTG-2 Shotgun Mic Kit:** Includes NTG-2 Shotgun Mic, Rode SM3 On-Camera Shockmount, Hosa MIT-156 Low to High Impedance Matching Transformer, Mic Stand Mount, Windscreen and Zippered Pouch (B&H # RONTG2K2) B&H Kit .....**269.95**

**NTG-2 Shotgun Mic/Boom Kit:** Includes NTG-2 Shotgun Mic, Rode SM3 On-Camera Shockmount, Rycote 14cm Medium Hole Softie, K-Tek KE89CC Aluminum Boompole with Coiled Cable, Impact Universal Microphone Hand grip, 1.5' and 20' Right Angled XLR cables and Impact Neoprene Boompole Bag (B&H # RONTG2BK) .....**579.95**

## VIDEOMIC Directional Condenser Microphone

The VideoMic is a professional grade shotgun mic designed for use with high quality DV/HDV camcorders. The mic exhibits low noise and an unusually wide bandwidth for its size. It is ultra lightweight, yet rugged due to its ABS construction.

The VideoMic is powered by a standard 9v battery and offers a Low Battery LED status indicator and a switchable high pass filter to reduce unwanted low frequency rumble. Attaches to any camcorder that has a standard camera-shoe fitting and utilizes a stereo mini jack for audio output.

- ◆ Broadcast sound quality
- ◆ Low noise circuitry
- ◆ Integrated shockmount
- ◆ Two step High-Pass Filter - Flat or 80Hz
- ◆ Rugged reinforced ABS construction
- ◆ 9V battery powered
- ◆ Integral camera-shoe mount
- ◆ Low handling noise

**VideoMic:** Camera Mounted Shotgun Microphone (Mfr # VIDEOMIC • B&H # ROVM) .....**149.00**



## CS-1

### Short Condenser Shotgun Microphone

The CS-1 is a professional shotgun microphone designed for film, video and broadcast applications. Its slim, compact design allows on-camera mounting without obstructing the camera's view. The CS-1's cardioid polar pattern and off-axis rejection combine to deliver focused, targeted signal while eliminating noise and ambiance at the perimeter of the capsule. Delivers narrow angle directivity in all frequency ranges—23dB/20kHz, 25dB/10kHz, 26dB/1kHz, 20dB/200Hz.

Utilizing Sanken's original square condenser capsule, the CS-1 has a flat frequency response well beyond 20kHz, while a high SPL rating of 137dB allows reproduction of transient signals with no distortion, even at close proximity.

Only 7" long, the CS-1 is ideal for mounting on video and film cameras, and weighing only 3.5 oz., it is easy to maneuver on a boom pole. It is also effective as a handheld shotgun mic. Supplied rubber O-rings are designed to expand the diameter of the CS-1 to match larger shock mounts attached to camera bodies (Canon XL-1, Sony DSR-PD-170).

**CS-1:** With foam windscreen and rubber O-ring (Mfr # CS-1 • B&H # SACS1) .....**795.00**

**KS-1 Mic Shockmount:** Firmly holds the CS-1 in two specially formulated polymer mounts (Mfr # KS1 • B&H # SAKS1) .....**135.00**

**WH-1 High Wind Cover:** Constructed of an acoustic foam base covered by a thick specially designed synthetic fur fabric. Attenuates high wind and atmospheric noises that compromise audio quality (Mfr # WH-1 • B&H # SAWH1) .....**55.00**

**Rubber O-Rings:** Set of 10 to expand the CS-1's diameter to fit the larger shockmounts (Mfr # ROCS • B&H # SAROCS) .....**20.00**

**US-1 Foam Windscreen (repl.):** Effectively reduces wind noise indoors and outdoors (Mfr # US-1 • B&H # SAUS1) .....**30.00**

**KCS Camera Adapter:** Designed to couple a CS-1 with a Sony camera. Fits in the camera microphone collar and adapts to a 3/8-16 thread. (Mfr # KCS • B&H # SAKCS) .....**25.00**

**KCC Camera Adapter:** Designed to couple a CS-1 with a Canon camera. Fits in the camera microphone collar and adapts to a 3/8-16 thread. (Mfr # KCC • B&H # SAKCC) .....**25.00**

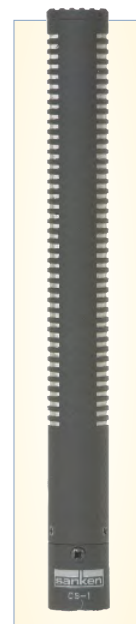

**KG Handgrip:** Universal handgrip for CS-1 and CS-3e shockmounts. Easily attaches to pole or stand (Mfr # KG • B&H # SAKG) ..... **65.00**

**KGW Wired Handgrip:** Same as above, but wired with cloth covered cable for maximum noise isolation (Mfr # KGW • B&H # SAKGW) .....**100.00**

## CS-3E Short Shotgun Microphone

The CS-3e provides convenient camera mountable size with the directional signal reproduction and range of much larger shotgun mics. Designed for directional dialog capturing in studios or on location.

The CS3e implements three-directional capsules arranged in a front-to-back array resulting in phenomenal supercardioid directivity at high, mid and low frequencies. By rejecting undesired noise and sounds coming from the rear and sides, it picks up the targeted frontal sound sources with exceptional clarity over a wide frequency range - even in noisy ambient environments or in long reverberation spaces. Capable of maintaining high signal quality at longer distances, the CS-3e is ideal for ceiling and overhead placement. In addition to exceptional super-cardioid off-axis rejection, the mic capsule eliminates low-frequency proximity effect when used close to the signal source. Only 10" long, the CS-3E is ideal for camera or boom pole mounting.

- ◆ Three directional capsules are arranged in a front-back array to combine line microphone performance and second-order pressure gradient response in a single system.
- ◆ Achieves phenomenal supercardioid directivity in the lowest frequencies and throughout the full range in a microphone 10" long.
- ◆ Conventional shotgun microphones use a line capsule array and a pipe with slits in front of the capsule to create high directivity by utilizing phase interference inside the casing. However, low/middle frequency range isn't achieved, although high-directivity in the high frequency range is maintained. Shotgun mics designed for high directivity in the middle/low frequencies need to be almost 40" long, seriously affecting mobility and are not ideal for field recording.

- ◆ The CS-3e offers switchable shotgun stereo/mono/wide, and has a low-cut switch to satisfy the various needs of location and studio recording. 19mm diameter permits use of a wide range of accessories developed for enhanced performance and field mobility.
- ◆ The CS-3e virtually eliminates proximity effect and maintains sharp directivity, while the sonic characteristics do not change with varied distances between sources and microphone.

**CS-3E Short Shotgun Microphone** (Mfr # CS-3E • B&H # SACS3E) .....**1350.00**

**KS-3 Mic Shockmount:** Firmly holds the CS-ee in two specially formulated polymer mounts. (Mfr # KS3 • B&H # SAKS3) .....**135.00**

**CB-483 II Phantom Power Supply:** Operates on a single 9-volt battery and supplies +48V phantom power as well as providing attenuation and low-cut filter. (Mfr # CB-483 II • B&H # SACB4832) ..... **499.00**

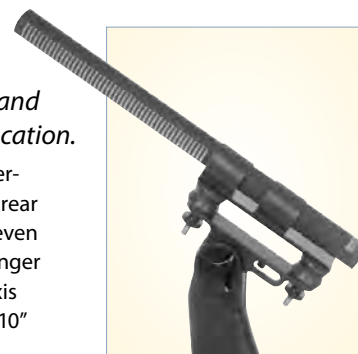

## SANKEN

## CSS-5

## Stereo Shotgun Microphone

Based on five directional condenser elements, the CSS-5 is equally responsive in the horizontal and vertical planes with high sensitivity, wide frequency response and excellent dynamic range. For film / video documentarie and major broadcast events, it is desirable to record targeted sounds precisely, with the added option of capturing realistic stereophonic perspectives. Stereophonic localization depends primarily on signal accuracy and channel separation in the 400Hz to 3kHz range. Pattern control of the CSS-5 has been optimized in this range. Very low and very high frequency response is optimized along the frontal axis so that the "target" on-axis sounds are clearly delineated. The result in playback accentuates the frontal image, with side signals positioned slightly behind.

The directional capsules combine line microphone performance and second-order gradient response in a single system. High directivity is achieved in a microphone less than 12" long. The CSS-5 is small and lightweight with switchable mono / stereo functions. 19mm diameter allows use of a wide range of accessories for enhanced performance and field mobility. The CSS-5 provides three switchable modes to satisfy the various needs of location and studio recording.

## Normal Mode

In the NORMAL mode, the CSS-5 clearly picks up the targeted sound as well as extremely accurate stereo localization. The STEREO angle is approximately 115°.

## Mono Mode

In MONO mode, sharp directivity is maintained over a wide frequency range for the aimed frontal sound sources, using the combination of a second gradient mic and a line mic. The CSS-5 picks up the sound source very clearly even in noisy ambient situations.

## Wide Mode

WIDE mode is designed for stereo recording of sound effects where dialogue will be dubbed in at a later date. This mode allows a wider 140° degree pickup, whereas conventional M-S microphones have a maximum of 127°.



(SACSS5)  
1,995.00

<b>CSS-5:</b> Stereo Shotgun Microphone (Mfr # CSS-5 • B&H # SACSS5).....	<b>1995.00</b>
Two-Channel Portable Phantom Power Supply for the CSS-5 (Mfr # CB-485 II • B&H # SACB4852).....	<b>499.00</b>

## CMS-10

## Camera Mountable Stereo/Mono Shotgun Mic

The industry-standard for use with today's HD cameras, the compact and lightweight CMS-10 provides extremely high-resolution audio to match today's advanced picture quality. Uses M-S design to provide stereo or mono with superior frontal directionality and a rejection of sound from the sides and back, making it ideal for noisy shooting or reverberant environments. Mono/Stereo switch allows output of a highly directional mono signal to both L/R channels. The supplied suspension camera-mount eliminates vibrations from both camera and operator movement. Condenser elements use PPS (Poly-Phenylene Sulfide) diaphragms to provide exceptional response and optimum humidity / temperature stability.

- ◆ The CMS-10 uses a unique second-order pressure gradient design, enabling precision directional response through multiple cardioid elements in a front-back array. The capsules combine line microphone performance and second-order gradient response in a single compact (8.6" long) system.
- ◆ Virtually eliminates the proximity effect in spite of sharp directivity, while the sonic characteristics do not change with varied distances between source and microphone. This is a significant advantage over all other directional microphones.

- ◆ Pattern control is optimized in the 400Hz to 3kHz range. this range. Very low and very high frequency response has been optimized along the frontal axis so that the "target" on-axis sounds are clearly delineated. The result in playback accentuates the frontal image, with side signals positioned slightly behind.

**CMS-10 Shotgun Stereo Mic** (Mfr# CMS-10 • B&H# SACMS10)  
With SH-10 Suspension Holder and WSJ-10 Softie.....**2195.00**



## ME66

### Short Condenser Shotgun Microphone Capsule

A popular choice among video, film and ENG/EFP professionals, the ME66 offers classic Sennheiser shotgun mic sound, extremely high sensitivity, and very low-self-noise, resulting in unprecedented "reach" characteristics for a mic that can be powered by AA batteries. The ME66 capsule features a highly directional, cardioid polar pattern yielding great attenuation at the sides of the mic, maximizing pick up at the front. The result is a focused pick-up in highly ambient environments, meaning its great for interviews in crowded situations. Wide, extremely smooth 40Hz-20kHz frequency response provides for neutral, uncolored sound in the low- and mid-range frequencies and a gentle boost in high frequencies, for increased intelligibility. The ME66 capsule is powered by the K6 modular power supply. The K6 houses a standard AA alkaline battery and is also capable of accepting phantom power from outside sources. Its compact design allows camera mounting while remaining free of the frame.



ME66 with K6 Power Supply



ME66 / K6 Kit

- ME66:** Short Shotgun Condenser Mic Capsule for K6/K6P (Mfr # ME66 • B&H # SEME66) ..... **CALL**
- ME66/K6:** - Same as above with K6 Power Supply. (B&H # SEME66K6J) ..... **CALL**
- ME66/K6P:** Same as above with K6P (Phantom Only) Power Supply (Mfr # ME66/K6P COMBO • B&H # SEME66K6P) ..... **CALL**
- ME66/K6 Kit:** ME66 with K6 Module, Windtech SG-1 Windscreen, Rode SM3 Shockmount, 1.5' Angled XLR cable. (B&H # SEME66K6K) ..... **479.95**
- ME66/K6 Kit 2:** ME66 with K6 Module, Windtech SG-1 Windscreen, Rode SM3 Shockmount, Hosa MIT-156 Low to High Impedance Matching Transformer. (B&H # SEME66K6K2) ..... **479.95**
- ME66/K6 Boom Kit** ME66 with K6 Module, Rode SM3 Shockmount, Rycote 18cm Medium Hole Softie, K-Tek KE89CC Aluminum Boom pole with coiled cable, Impact Universal Mic Hand Grip, 18" and 20' angled XLR cables, Pearstone Neoprene Boompole Bag. (Mfr # ME66BK • B&H # SEME66BK) ..... **749.95**
- ME66/K6 Deluxe Boom Kit:** Same as above except with K-Tek KE100CC Avalon 5-Section Graphite Fiber Boom Pole (Mfr # ME66DK • B&H # SEME66DK) ..... **969.95**

The ME-66 and ME-67 are powered by the K6 or K6P powering modules. They can run for 150 hours on a single AA battery, or can be used with 12 to 48v phantom power. The K6 features an on/off switch with LED battery status indicator; and a bass roll-off switch which will compensate for proximity effect in close miking, or for wind rumble in field recording. The K6P phantom powering (only) module provides an alternative to the K6 that is 42mm shorter, while offering the same integrated bass roll-off switch.

## ME67 Super-Cardioid Spot Shotgun Condenser Microphone

The ME-67 is a long shotgun mic capsule designed primarily for capturing low-level sounds. Its extremely directional design brings distant sound sources into close range, with the extremely tight focus of the on-axis signal. As with the ME66, its frequency response has been optimized for a natural presentation, with good articulation of high frequencies. With a precise combination of high sensitivity and low self-noise, the ME67 is outstanding in difficult acoustic environments. Frequency response is 40Hz - 20kHz. Powered via the K6 and K6P powering modules, the ME67 comes in matte black with an anodized, scratch resistant finish.

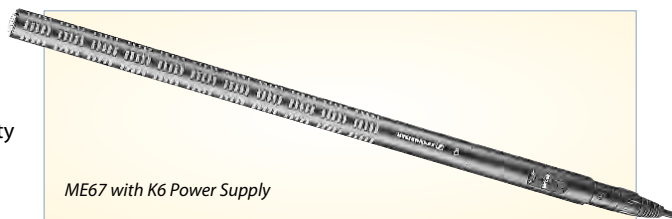

ME67 with K6 Power Supply

### ME-67 Long Shotgun Capsule

- ME67:** Super-Cardioid Spot Shotgun Condenser Microphone Capsule for K6/K6P (Mfr # ME67 • B&H # SEME67) ..... **299.95**
- ME67/K6** - Same as above with K6 (Battery/Phantom) Power Supply (Mfr # ME67K6 • B&H # SEME67K6) ..... **468.95**
- ME67/K6P** - Same as above with K6P (Phantom Only) Power Supply (Mfr # ME67K6P • B&H # SEME67K6P) ..... **499.95**
- ME67/K6 Boom Kit:** ME67 with K6 Powering Module, 2AA batteries, Audio Technica AT8415 Universal Shock Mount, AT8469 Camera Shoe Mount to 5/8-27" Threaded Base Adapter, K-Tek K-SUS Microphone Suspenders (Pair), Rycote 29cm Medium Hole Softie, K-Tek KE89CC Aluminum Boom pole with coiled cable, Impact universal hand grip, 18" and 20' right angled XLR cables. (B&H # SEME67BK) ..... **874.95**
- ME67/K6 Deluxe Boom Kit:** Same as above except with K-Tek KE100CC Avalon 5-Section Graphite Fiber Boom Pole (B&H # SEME67DK) ..... **1,089.95**

## MKH-416

### Super-Cardioid Short Shotgun Microphones

The black, all-metal MKH-416 is a short gun interference tube microphone. Its excellent directivity and compact design, high consonant articulation and feedback rejection make the MKH-416 a superb all-round microphone for film, radio and television, especially for outside broadcast applications. Transformerless, RF condenser designed as a combination of pressure gradient and interference tube microphones. Features high sensitivity, very low inherent self-noise, low proximity effect and can handle SPL up to 128dB. Rugged and resistant to changing climate conditions. Ideal for boom, fishpole, and camera mounting as a long-distance microphone for video, film, and studio recording. An excellent ENG mic for reporters or as a podium or lectern microphone.



- MKH-416:** With MZW-415 Windshield (Mfr # MKH416-P48U3 • B&H # SEMKH416P48) .....**CALL**
- MKH-416 Deluxe Kit:** Includes: MKH-416, Universal Shockmount, Rycote Softie, cabled Boom Pole, Universal Hand Grip and right angled XLR cables. (B&H # SEMKH416DK) .....**1699.95**
- MKH-416 Ultimate Kit:** Includes MKH-416, Rycote Windshield Kit, cabled Boom Pole and Canare XLR cable. (B&H # SEMKH416UK) .....**2259.95**

### RF Condenser Microphones

MKH condenser mics represent the perfect fusion between exceptional sound and precision engineering, and have long been the choice of the most demanding professionals in the broadcast, theatrical, and motion picture industries. Their extremely transparent sound, high sensitivity, and excellent S/Nratio are perfectly complemented by their exceptionally low inherent self-noise, extremely low distortion, and unusually flat, linear frequency response. Lightweight, durable, and weather-resistant construction makes them suitable for outdoor applications. In every MKH mic, the capsule is part of a tuned circuit in a radio frequency system. This makes them highly immune to humidity, and is responsible for their exceptionally low self-noise. In addition, their symmetrical push-pull capsule design incorporates optimum resistive loading, which virtually eliminates intermodulation distortion.

## MKH-60 • MKH-70

### Short and Long Super-Cardioid Shotgun Microphones

Versatile and easy to handle, the MKH-60's superb lateral sound muting makes it an excellent choice for film and reporting applications. High degree of directivity throughout the whole frequency range ensures high sound quality for distance applications. Incorporates short interference tube RF condenser, lightweight metal alloy, and transformerless, low noise symmetrical capsule design. Phantom-powered, it features smooth off-axis frequency response, switchable low cut filter (-5dB at 100Hz), high frequency boost (+5dB at 10kHz) and 10dB attenuation. Handles very high SPL (135dB). Widely used in film, theater and TV productions. Ideal for broadcast, sports and interviews in crowded or noisy environments. Excellent for studio voice-overs. The MKH-70 is a lightweight, long shotgun microphone. Its excellent directivity is particularly suited to shooting in difficult conditions, such as high background noise and distance microphone positioning. Its frequency-independent directivity prevents sound coloration from off-axis sound sources. Extremely rugged, the MKH-70 features low distortion push-pull element, low noise, switchable presence (+5dB at 10kHz), low cut filter (-5dB at 50Hz) and 10dB pad. Handles 133dB SPL with excellent sensitivity and high output level. Ideal for video/film studios, theater, sporting events, and nature recordings.



- ◆ Exceptionally low inherent self-noise
- ◆ Transformerless and fully floating balanced output
- ◆ Lightweight, rugged, weather-proof black anodized metal bodies
- ◆ Infra-sonic cut-off filter
- ◆ Switchable pre-attenuation, roll-off filter and treble emphasis
- ◆ Symmetrical transducer technology ensures extremely low distortion

- MKH-60:** with MZQ-40 stand adapter (Mfr# MKH60-P48 • B&H# SEMKH60) .....**1539.95**
- MKH60 Kit:** Includes: MKH-60, Rycote Windshield Kit, cabled Boom Pole and Canare XLR cable. (B&H # SEMKH60UK) .....**2619.95**
- MKH-70:** (Mfr# MKH70-P48 • B&H# SEMKH70) .....**1649.00**

## MKH-418S

### Stereo Shotgun Microphone

The MKH-418S is a professional stereo shotgun microphone featuring high constant articulation, excellent feedback rejection and functional versatility—making it a superb all-round, cost-effective choice for film, television, and multi-media applications. The MKH-418S incorporates Mid/Side (M/S) technique, yielding a high degree of directivity and focus while reproducing signals with extreme accuracy to their perspective placement, within the L/R stereo field.

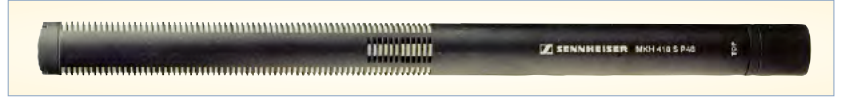

- ◆ The MKH 418S features 2 independent acoustic systems for generating the mid and side signals. The mid (M), or mono signal is generated using an internal shotgun microphone that accurately reproduces audio with extreme focus, emphasizing pick up of signals at the direct-axis section (front). It also rejects signal at the off-axis sections (sides) of the microphone, minimizing noise and further strengthening the pick up area. The Side (S), or stereo signal is generated using a separate, internal mic system that features a figure-of-eight polar pattern. This system is responsible for reproducing the spacial character needed for accurate placement of signal within the stereo field.
- ◆ 5-pin XLR output, capable of sending the separate signals of each internal microphone system to discrete channels of a console, field mixer, recorder or matrixing system.
- ◆ Each internal microphone requires +48V phantom power, supplied via two Sennheiser MZA 14 P48 battery power supply units, or any mixer capable of supplying at least 2 discrete channels of phantom power.

**MKH-418S** (Mfr # MKH418S • B&H # SEMKH418S) .....**1659.95**

### MZS20-1:

Combination shock mount, pistol grip and stand adapter for ME-66 and ME-67 as well as MKH Series microphones.

- ◆ Required for mounting in MZW "blimp" windscreen.
- ◆ May be boom or stand mounted. Requires MZA-216 adapter (included).
- ◆ Includes interchangeable mic clips for MKH-416 or MKH-60/70.

**MZS20-1** (Mfr # MZS20-1 • B&H # SEMZS201).....**343.50**



### Blimp Windshields (Require MZS20-1)

Rigid "blimp" windscreen for ME66, MKH-416 and MKH-60.

(Mfr # MZW60-1 • B&H # SEMZW601) .....**309.95**

Rigid "blimp" windscreen for ME-67/MKH-70.  
(Mfr # MZW70-1 • B&H # SEMZW701) .....**348.50**

### Long Hair Wind Muffs

Long hair wind muffs greatly reduce high velocity wind-noise when used with MZW series blimp windshields and MZS-20-1 pistol grip/shock mount.



For ME-66, MKH-416, MKH-60 (Mfr # MZH60-1 • B&H # SEMZH601) .**199.95**

For ME-67, MKH-70 (Mfr # MZH70-1 • B&H # SEMZH701) .....**214.95**

## SHURE SM89

### Shotgun Condenser Microphone

The SM89 is a highly directional condenser shotgun mic ideal for on-location film, television production, spot news coverage and wildlife recording.

- ◆ Discriminates at a distance against ambient noise – even in noisy surroundings.
- ◆ On-axis frequency response is very smooth and extended. For clarity and speech intelligibility, a slight presence rise optimizes the high-frequency response to compensate for high-frequency losses.
- ◆ Low-frequency roll-off minimizes pickup of wind, mechanical vibration and ambient noise without affecting voice frequencies.
- ◆ Off-axis response is virtually free of comb-filter effects. This is important when you can't aim the mic precisely or when you want to pick up dialogue or sound from moving sources.
- ◆ Operates on 11 to 52v DC phantom supply.
- ◆ Extremely lightweight, can be suspended on fishpole for long periods of time without operator fatigue.
- ◆ Includes foam windscreen and strong luggage-grade carrying case.

**SM89** (Mfr # SM89 • B&H # SHSM89) .....**629.95**

**A89SM Shockmount:** Designed for the SM89, the A89SM utilizes dual shock isolators and a cable locking design to eliminate noise associated with stands, booms, fishpoles, and cable movement. Mounting options include 5/8", 3/8" and 5/16" thread adapters for stands and booms .....**99.95**



## VP88 M-S

## Single Point Stereo Condenser Microphone

The VP88 is a single-point, stereo condenser mic for use in field production, electronic news gathering (ENG), and studio broadcasting applications. It combines two condenser cartridges in a single housing to create a stereo audio image of the sound source. It is unique in its ability to capture the realism of a live event and yet able to withstand the rigors of field production.

The VP88 uses a time-coherent mid-side (M-S) design for optimal stereo imaging. One mic cartridge (Mid) faces forward to capture on-axis sound using a cardioid pickup pattern. The other mic cartridge (Side) is bi-directional, capturing sound from either side. The VP88 contains an internal M-S matrix with three settings for different degrees of stereo image separation. The internal matrix can be bypassed if an external matrix is used or if stereo imaging is done in post-production. Switches on the top of the microphone control output mode, stereo imaging, low-frequency rolloff settings, and battery on/off.

- ◆ Mono compatibility ideal for broadcast applications.
- ◆ 40 to 20kHz frequency response; low noise and distortion; wide dynamic range.
- ◆ Selectable, low-frequency rolloff (12dB/octave below 80Hz) for reduced pickup of ambient noise and stand vibration.
- ◆ Internal shock mount for reduced handling noise.
- ◆ Built-in "pop" filter provides protection against moderate breath or wind noise.
- ◆ Operates on phantom power or a 6v camera battery.
- ◆ LED power indicator.
- ◆ Supplied with a multi-connector "Y-splitter" cable, foam wind-screen, swivel stand adapter, 6v battery, and zippered case.



**VP88 M-S: Cardioid Stereo Condenser Mic** (Mfr # VP88 • B&H # SHVP88) .....**689.95**

**25' Extension Cable for VP88** (Mfr # C110 • B&H # SHC110) .....**66.95**

**A88SM Isolation Shockmount:** The A88SM provides optimum isolation from stand-transmitted shock and vibration, making the VP88 M-S ideal for critical studio applications. It also contains a standard mounting foot for use with most ENG video cameras (Mfr # A88SM • B&H # SHA88SM) .....**158.50**

## SCHOEPS CMIT 5U

## Professional Condenser Shotgun Microphone

Designed for professional film and video, the CMIT 5U is a long shotgun microphone that captures dialog with great detail and accuracy. Lightweight with a robust, all-metal housing, the mic features a directional pattern with low-coloration at the off-axis sections of the capsule. At medium frequencies the directivity of the CMIT 5U is higher than one would expect from a mic of this length, while at high frequencies the pickup pattern is not as narrow as with long shotgun microphones. Thus in active scenes it is easier to cue the boom and keep actors "on mike."



At medium frequencies the directivity of the CMIT 5U is higher than one would expect from a mic of this length, while at high frequencies the pickup pattern is not as narrow as with long shotgun microphones. Thus in active scenes it is easier to cue the boom and keep actors "on mike."

- ◆ Unlike some other shotgun microphones, the directional pattern and sound quality are consistent in both the horizontal and vertical planes.
- ◆ Three pushbutton-activated filters allow the microphone to adapt to all recording situations:
  - High-frequency emphasis (+ 5 dB at 10 kHz) enhances speech intelligibility, and compensates for high-frequency loss caused by windscreens;
  - A steep low-cut filter (18 dB/oct. below 80 Hz) suppresses wind and boom noise;
  - A gentle low-frequency rolloff (6 dB/oct. below 300 Hz) compensates for proximity effect.
- ◆ Pairs of LEDs next to each pushbutton indicate the status of the filters. Even in darkness you can read the settings and see that the microphone is operational. The settings are retained when the microphone is switched off.

**CMIT 5U** (Mfr # CMIT5U • B&H # SCCMIT5U)

Includes polished wood carrying case, SG-20 swivel joint, W140 foam-type windscreens .....**1995.00**



## ECM-673 • ECM-674 • ECM-678

### Electret Condenser Short Shotgun Microphones

Sony's short shotgun microphones (ECM-673, ECM-674, ECM-678) deliver excellent sound performance in field and studio production applications at an affordable price. Optimized for use with Sony compact camcorders such as the HDV™ Series and DVCAM Series, they offer high sensitivity, low-noise characteristics, and a flat-and-wide frequency response in a compact and lightweight body.

In addition, their highly directional response and extreme durability allow clear voice pickup, even in harsh operational environments. With its high performance, compact design, and high durability, they are the ideal choice for quality-critical sound acquisition applications.

ECM-678 shown  
in a mount

ECM-673

#### FEATURES

- ◆ The ECM-673 and ECM-674 offer an excellent sensitivity of -36dB and a low inherent noise level of less than 17 dB SPL. This allows them to be used for clear voice pickup, even in noisy environments.
- ◆ The ECM-678 delivers a superb sensitivity of -28dB and low inherent noise of less than 16dB SPL providing the clearest pickup of even the faintest sounds at long distances.
- ◆ They have a flat and wide frequency response (40 Hz to 20 kHz) and deliver extremely smooth and natural sound reproduction.
- ◆ They are designed as highly directional, compact and lightweight short shotgun mics maintaining good balance even when mounted on compact camcorders.
  - ECM-673 is 7 7/8" long and weighs 4.7 oz.
  - ECM-674 is 10 3/8" long and 6.5 oz.
  - ECM-678 is 9 7/8" long and 7 oz.
- ◆ The vibration-resistant mechanisms of the ECM-673 and ECM-678 offer high durability and reliability, making them suitable for the harshest environments in field sound acquisition.
- ◆ Each features a built-in two-position (M, V) low-cut switch providing a simple method of reducing the effects of unwanted ambient noise.
- ◆ The mics are powered by external DC 40-52v phantom power. The ECM-674 can also be powered by a AA battery. In addition, the ECM-674 has a built-in battery liquid leakage protection circuit.

## ECM-680S

### MS Stereo Shotgun Microphone

An MS stereo shotgun mic, ideal for a broad range of field production and broadcast studio applications. It offers excellent sensitivity, low inherent noise, and a flat-and-wide frequency response. The most distinguished feature of the ECM-680S is its switchable operation between a highly directional monaural mode and stereo mode. Monaural mode provides highly directional sound pickup, while stereo mode delivers natural and spatial sound. Compact and lightweight, the ECM-680S is well-suited to use with a range of professional camcorders. In addition, it can be mounted on a boom pole for more versatility.



- ◆ Can operate in stereo mode—for capturing environmental sound with natural sound quality, or monaural mode—for clearly capturing voice and sound from a distance.
- ◆ Uses the Mid-Side (MS) technique that offers natural stereo sound and excellent localization. Equipped with large diaphragm mic capsules with bi-directional characteristics, the ECM-680S delivers a superb sensitivity of -28 dB (stereo)/-32 dB (monaural), and extremely low inherent noise of less than 20 dB SPL (stereo/monaural).
- ◆ Has a flat-and wide frequency response (50 Hz to 20 kHz (stereo)/40 Hz to 20 kHz (monaural)) in both stereo and monaural modes, and will provide sound reproduction that is extremely smooth and natural.
- ◆ Built-in two-position (M, V) low cut switch provides a simple method of reducing the effects of undesired ambient noise.
- ◆ Only 9 7/8" long and less than 4.9 oz. the ECM-680S maintains good balance and mobility when mounted on a range of professional camcorders.

<b>ECM-673</b> (Mfr # ECM673 • B&H # SOECM673) .....	<b>295.00</b>
<b>ECM-674</b> (Mfr # ECM674 • B&H # SOECM674) .....	<b>345.00</b>
<b>ECM-678</b> (Mfr # ECM678 • B&H # SOECM678) .....	<b>650.00</b>
<b>ECM-680S</b> (Mfr # ECM680S • B&H # SOECM680S) .....	<b>850.00</b>

## PARABOLIC MICROPHONES

### BIG EARS

#### Parabolic Microphone Kit

*The Big Ears parabolic reflector was designed to make impossible sound gathering situations easy for both field recordists and broadcast professionals. It is constructed from a custom plastic material that has been specially developed to deliver remarkable audio clarity over a wide frequency range, without the cumbersome weight. The dish is molded to extremely tight tolerances and its "sweet spot" can be fine-tuned to adjust to varying situations. There are even two side mounting plates to accommodate mounting transmitters and receivers for wireless communications.*



\*Not for tactical use

Latest generation of the state of the art parabolic microphone reflector . Comes complete with Sport handle set, transmitter attachment plate and universal Mic yoke. Big Ears uses acoustically isolated foam vinyl covered handles that also acts as a support bar for freestanding use. Two side mounting plates are incorporated in the handle design to accommodate mounting of transmitters and receivers for wireless communications. The handles and microphone yoke are easily detachable for convenient nested storage of multiple units.

Because the unit is often used in sports situations, significant thought has been given to the safety of the design. The dish is shatter and break resistant and the handle materials are selected and assembled with safety in mind. Big Ears is lightweight and can be easily mounted permanently when the need occurs.

- ◆ Pick-up Pattern: 30" diameter target at 100' (tunable)
- ◆ Useful Range: 5' to 500+' maximum (dependent on environment, atmospheric conditions and surrounding noise levels)
- ◆ Size: 25.5" x 26.5" x 10" ◆ Parabola size: 23" ◆ Weight: 5 lbs.

**Big Ears Super Kit:** (Mfr # BE3K/SCLEAR • B&H # CRBE3KSC): Includes BE3 Big Ears Parabolic Dish (Clear), Custom Sennheiser MKE 2 Mic, Lavalier Holder, HD1 Headphone, MD1 Bridging Amplifier, RD1 Electronic Site, DS1 Neck Strap, Carrying Case and Silent Gloves .....**4499.00**

### LIL' EARS Parabolic Microphone Kit

*The Lil' Ears parabolic reflector is the ENG version of Big Ears. Designed along the same guidelines as its bigger brother with a smaller package in mind, it comes complete with handle and yolk. Ideal when it isn't possible to make use of a larger dish in tight ENG environments— since large size may prohibit mobility and the coverage distances may not be as great. The smaller size is also a plus when it comes to speed and portability. This ready-to-use broadcast package comes complete with handle and yoke, and is designed for handheld, mic stand, or camera mount use.*



- ◆ Pick-up Pattern: 24" diameter target at 100' (tunable).
- ◆ Useful Range: 3' to 350+' maximum (dependent on environment, atmospheric conditions, and surrounding noise levels).
- ◆ Size: 16" x 15" x 5" overall.
- ◆ Parabola size: 13".
- ◆ Weight: 2 lbs.

**Lil' Ears Parabolic Microphone Super Kit** (Mfr # BE4K/SCLEAR • B&H # CRBE4KSC)

Includes BE4 Lil' Ears Parabolic Dish (Clear) , Custom Sennheiser MKE 2 Microphone, Lavalier Holder, HD1 Headphone, MD1 Bridging Amplifier, RD1 Electronic Site, DS1 Neck Strap, Carrying Case and Silent Gloves .....**2999.95**