





The Professional Video

SourceBook

Section 5

TRIPODS & BOOMS

- Cambo412-415
- Cartoni.....416-427
- Dykortech428
- Gitzo429
- Glidecam430
- Hi-Pod.....431
- JonyJib432
- Libec433-439
- Manfrotto440-449
- Matthews.....450-454
- Miller.....455-466
- OConner467-469
- Sachtler470-488
- Slik-Daiwa489-493
- Spider Pod494
- Vinten495-507

Obtaining information and ordering from B&H is quick and easy. When you call us, just punch in the corresponding Quick Dial number anytime during our welcome message. The Quick Dial code then directs you to the specific professional sales associates in our order department.

 For Section 5, Tripods & Booms
use Quick Dial #: 821

V-SERIES BOOMS

Professional boom effects are quick and easy to achieve with the V-Series professional video booms from Cambo. Designed to be highly transportable, compact and simple to use, these booms operate with the widest range of video cameras, from compact digital to the latest ENG models. Perfect for today's videographers who need to be where the action is.



V5 Lightweight Telescopic DV Boom

The V5 is a lightweight telescopic DV boom designed to carry a maximum load of 7 lbs. and has a standard mechanical tilt option ($\pm 60^\circ$). The boom is especially made for quick set-up and is very light (12 lbs.) with a compact packed size (folds down to 46"). The V5 boom has an extension range from 4.4' to 9' from tripod to boom end. The boom tail uses standard fitness weights and slides into the main boom section for either counterweight adjustment or packing. The weight bar, including weights, can be taken from the tail (one knob) for an even more compact travelling size.

- ◆ The V-5 uses vertical set-up for even more compact construction.
- ◆ Used for the tilt movement, the handle is adjustable to fit the users need. It can be fixed to keep the camera level or in the same angle throughout the vertical boom movement.

- ◆ The length of the steering cable is easily adjustable to fit the telescopic set-up of the boom. It rolls on to a wheel next to the steering handle.

V-5 Lightweight Telescopic DV Boom

(Mfr # 99134010 • B&H # CAV5TDB) **1998.50**

V15 Lightweight Jib Kit

The V15 is a rugged, lightweight jib. Though it accepts camera weights in excess of 40 lbs, it was designed for the weight conscious videographer. The basic unit weighs only 18 lbs. and has a reach of 67" fully extended. It assembles and breaks down in seconds to a compact case 37" long. Modular interlocking design means easy setup, no screws or little pieces to assemble. Male/female parts provide tight tolerance for the most secure fit.

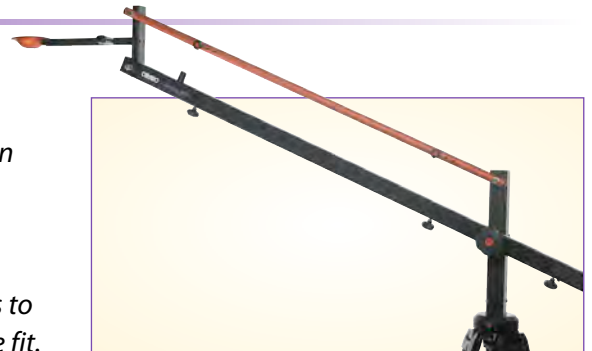

- ◆ 100mm bowl arm for camera levelling is detachable for easy storage.
- ◆ Mountable to a standard 75mm or 100mm video tripod. The ultra-smooth pan base features a locking facility.
- ◆ Utilizes a precision bearing base for very smooth camera movement.
- ◆ Central lock for quick set up and stability for fixed height shots.

- ◆ Adjustable friction control allows slow and fast movement along with being able to lock-down for a static shot.
- ◆ Adjustable counterweight system ensures a stable camera platform and quickly adjusts for different camera weights and positions (weights not included).

V-15 Lightweight Jib Kit (Mfr # 99134150 • B&H # CAV15MC) **1717.50**

V-15 ACCESSORIES

Ball and Arm Accessory (Mfr # 99134130 • B&H # CAV13BA) **187.50**
Extra Counterweight System (Mfr # 99134170 • B&H # CAV17ECS) **269.95**

31.5" Extra Extension (Mfr # 99134180 • B&H # CAV18CC) **259.95**
Angle Arm Unit (Mfr # 99134190 • B&H # CAV19AA) **436.95**



CAMBO

V40

Pro Video Boom

The V40 is the most complete boom system in the industry. Its modular approach offers sophisticated versatility you can't get anywhere else. Its unique interlocking joining system provides setup in minutes without sacrificing weight capacity. Extension bars allow for quick and easy addition of extensions from 2' to 16' long for a possible reach of just under 23'. The V40 features a smart counterbalance system that uses standard weights (not included). Its integrated fine-tuning block allows you to change lenses and batteries and adjust for the weight difference with ease. Disassembled, the longest component of this system measures less than 40". Weighing only 15 lbs., this compact boom travels anywhere - without breaking your back.



- ◆ Modular interlocking design means easy setup, no screws or little pieces to assemble. Male/female parts provide tight tolerance for the most secure fit.
- ◆ Detachable 100mm bowl arm.
- ◆ Fluid action base provides smooth pan-action base with locking facility.
- ◆ Counterweight system provides easy adjustment for a variety of camera weights and boom lengths.
- ◆ Quick detachment to add accessories like the PT90.
- ◆ Mountable to a standard 75mm or 100mm video tripod.
- ◆ System includes one V47 weight support.

V-40 Pro Video Boom (Mfr # 99134400 • B&H # CAV40)**2622.95**

V-40 ACCESSORIES

PT-900S Motorized Pan and Tilt Unit (Mfr # 99137906; B&H # CAPT900S)

Designed for DV and Mini DV cameras, the PT-900S has a weight capacity of 22 lbs, and provides precision-controlled motorized camera movements with the V40. The included PT-903 Control Unit operates the two motorized units for full camera control with 350° pan and/or tilt. A switchable direction control allows you to set rotation direction on both movements or switch either off. The maximum speed is determined by two independent controls. Includes camera platform, mount for V40, joystick control, 5m control cable and 100-240v AC/12v DC power



supply with a XLR-4 output connector. An optional V-battery mount is also available to accommodate many industry-standard batteries. The PT-900S also features an integrated LANC signal put-through connection.....**5,744.95**

Auxiliary Handle (Mfr# 99134410; B&H# CAV42)

Mounts in a different leverage location for specific remote operation. It allows the operator specific control and lift, making the V-40 more effective in various production applications.....**299.95**

Ball Arm Accessory (Mfr# 99134443; B&H# CAV43): Replacement**228.95**

LCD Screen Mount Adapter (Mfr# 99134444; B&H# CAV44) Secures the LCD monitor and mounts to the V-40**144.95**

Flexarm for LCD Mounting (Mfr# 99134445 • B&H# CAV45)

Works with a clamp to connect to the support equipment and offers a threaded screw-on mount to attach to an LCD screen.....**64.50**

Control Frame Deluxe (Mfr# 99134446 • B&H# CAV46)

Adds smooth control of movements and a convenient location for joystick control and an LCD screen**789.95**

Additional Counter Weight Mounting (Mfr# 9913444 • B&H# CAV47)

Included with the V-40, but available as extra option**249.95**

Double Fixed Counterweight Mounting (Mfr# 99134448 • B&H# CAV48)

Allows balanced extra weight to be attached to the V-40.....**364.50**

Super Clamp (Mfr# 99134449 • B&H# CAV49)

For mounting the V-45 Flexarm on to the V-15 or V-40.....**55.95**

V-50 Adapter (Mfr# 99131281 • B&H# CAV50)

Used to mount the V-40 on to a light tripod.....**93.50**

23.6" Tail Extension (Mfr# 99134454 • B&H# CAV54)**343.50**

39.3" Extension (Mfr# 99134455 • B&H# CAV55).....**374.50**

78.6" Extension (Mfr# 99134457 • B&H# CAV57)**582.95**

Soft Case for V-40 (Mfr# 99134490 • B&H# CAV444)

Securely holds a V-40 with a 39.3" extension**529.95**

Flightcase for V-40 (Mfr# 99134491 • B&H# CAV445)

Hard case with recessed latches and padding.....**1217.95**

Extension Support (Mfr# 99134520 • B&H# CAVCSS1)

For times when 3 meters or more of extension hardware is installed. It allows the longer boom lengths to operate without flex or sag.....**322.50**

ARTES

Video Boom System

A lightweight mini camera crane, the Artes is the perfect solution for weddings, corporate presentations and product shots. Designed to offer professional crane movement for small sized cameras and equipment, the jib features easy set-up and comes with a mechanical pan and tilt system. The manual tilt is easy to operate but achieves great dynamic results equal to those of more expensive crane

- ◆ Boom system is modular extended and this way usable in at least three different set-ups.
- ◆ Utilizes a low friction bearing base offering a very fluid and smooth camera movement.
- ◆ The central unit has four locking knobs for applying friction to the vertical boom movement and to make disassembling easier. The central rotation platform has a low friction bearing system with a rotation brake. It fits to all 75 and 100mm video tripod cups.
- ◆ Easy to set-up, Artes offers an interlocking design for easy assembly; no screws or small clamps, utilizes male/female connection with precision security. Modular system makes transporting it quick and easy
- ◆ The Artes weight system is based on a set of standard fitness weights (not included) with a set of (included) small fine-tuning weights. The system is expandable and mountable as side weights.

ARTES Video Boom with Fixed Camera Plate (Mfr # 99133050 • B&H# CAAVB): Includes base, standard platform and jib.....**1092.95**

ARTES Tilt Video Boom (Mfr # 99133052 • B&H# CAATVB) Includes tilt system, screen holder and extra weight system.....**1748.50**

ARTES Pan & Tilt Video Boom (Mfr # 99133053 • B&H# CAAMVB): Includes MPT-9 mechanical pan-and tilt unit, screen holder and weight system.....**2924.95**

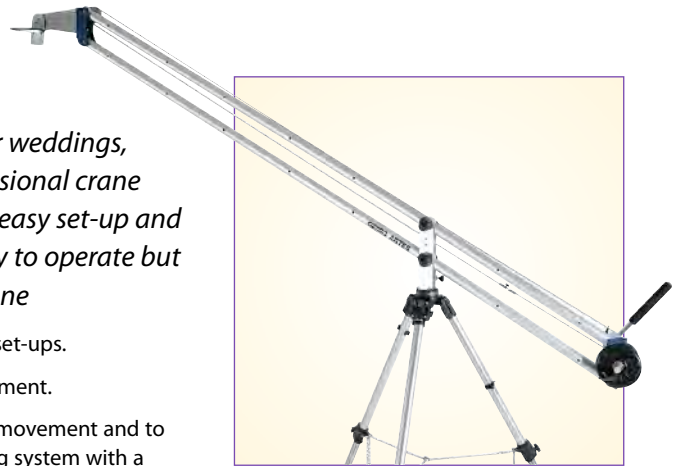

MPT-9 Mechanical Pan/Tilt Unit

For use with Cambo booms, the MPT-9 fits directly onto the Artes and V15 boom and uses a small adapter set to fit the V40. The camera unit weighs 5 lbs. and supports cameras up to 22 lbs. While the standard control unit has a combined pan/tilt handle, an optional handle set is available for independent pan and tilt control. Control units are attached to a modular tube frame that allows for personalized setups for the V15 and V40. The optional handle set also provides remote camera zoom and focus control possibilities. Adjustable friction control makes extremely smooth combined pan and tilt movements possible. Pan and tilt rotations are possible up to 340°, depending upon the flexibility of the setup.

MPT-9 Mechanical Pan and Tilt (Mfr # 99133063 • B&H # CAFSA)
For standard ARTES Boom Set.....**1829.95**

MPT-9 Mechanical Pan and Tilt (Mfr # 99134800 • B&H # CAFV15)
For Standard V-15 Boom Set.....**1873.50**

MPT-9 Large Mechanical Pan & Tilt (Mfr # 99134801 • B&H # CAFV15525)
For use on V-15 with 5.25' extension**1894.50**

MPT-9 Mechanical Pan & Tilt (Mfr # 99134805 • B&H # CAFV40)
For use on the standard V-40.....**2227.50**

MPT-9 Large Mechanical Pan and Tilt (Mfr # 99134806 • B&H # CAFV40W3.2): For V-40 Boom Set with 3.2' extension**2237.95**

MPT-9 Large Mechanical Pan and Tilt (Mfr # 99134807 • B&H # CAFV40W6.5)
For V-40 Boom Set with 6.5' extension.....**2247.95**

MPT-9 Large Mechanical Pan and Tilt (Mfr # 99134808 • B&H # CAFV40W9.7)
For V-40 Boom Set with 9.7' extension.....**2258.50**

MPT-9 Large Mechanical Pan and Tilt (Mfr # 99134809 • B&H # CAFV40W13.1)
For V-40 Boom Set with 13.1' extension**2268.95**

MPT-9 Large Mechanical Pan and Tilt (Mfr # 99134804 • B&H # CAFV40W16.4)
For V-40 Boom Set with 16.4' extension**2287.95**

PEDESTAL

VPS-1 Pedestal Column (Mfr # 99132910 • B&H # CAVP51)

A steady, versatile lightweight camera pedestal. An adjustable air-system provides accurate and effortless pneumatically-supported camera positioning. The top unit includes a steering wheel and a 100mm bowl accommodates a variety of tripod heads. It has a 44 lb. load capacity, a minimum height s of 30", and a maximum height of 43.75". It weighs 15.4 lbs.....**1,549.95**

VPD-9 Pedestal Dolly (Mfr # 99132920 • B&H # CAVPD9)

Designed for the VPS-1, the VPD-9 is a compact, lightweight, foldable dolly that remains on the column while folded. It also fits the Miller 480, 481, 483 and Manfrotto 114MV, depending on the configuration choice. Low camera position is possible while the 35cm vertical stroke is maintained. The VPD-9 features 4" locking wheels and a spider that allows the connection to the center pedestal.....**1144.95**

VPS-150 Pedestal Extension (Mfr # 99132911 • B&H # CAVPS150): 5.9" extension for the VPS-1.....**187.50**

VPS-300 Pedestal Extension (Mfr # 99132912 • B&H # CAVPS300): 11.8" extension for the VPS-1.....**197.95**

VPD-510 Cable Mover (Mfr # 99132930 • B&H # CAVPD510): Prevents the dolly wheels from running over the cable, allowing for better cable security while rolling. Package of three.....**199.95**



Pedestal column with dolly, extensions and cable movers.



VPD-4 Multi-Purpose 4-Wheel Dolly System (Mfr # 99132970; B&H # CAVPD4)

A high-quality four-wheel dolly that can be used as on-track or off-track dolly just by changing the wheels. The system includes a platform, a detachable rotating seat, specially-designed track wheels for any universal 62cm track, and a pneumatic pedestal. The VPD-4 Dolly System has a load capacity up to 462 lbs., and the seat is adjustable in height and distance to the pedestal**CALL**

VPD-76 Tripod Adapter Kit (Mfr # 99132976 • B&H # CAVPD76)**CALL**

VPD-78 Pneumatic Off-Track Wheel Set (Mfr # 99132978 • B&H # CAVPD78)**CALL**

VPD-79 Studio Wheel Set (Mfr # 99132979 • B&H # CAVPD79)**CALL**

VPSF-600 Fixed Pedestal for VPD-4 and VPD-9 (Mfr # 99132915 • B&H # CAVPSF600)**884.50**



UniTrack

Quick to setup on location, easy to level, and available in several length modules, the UniTrack allows the videographer to lay out and shape the track according to any desired routing. Straight tracks as well as curved tracks are possible with any shape or curve from straight into a tight radius. Adjustable cross bars assure a constant width of the system.

UTS-5 Dolly Track System (Mfr # 99132981 • B&H # CAUTS5) 16.4' track and rail system.....**5099.95**

UTS-5F Dolly Track System (Mfr # 99132985 • B&H # CAUTS5F) 16.4' track and rail system. Includes one flight case.....**6036.95**

UTS-10 Dolly Track System (Mfr # 99132982 • B&H # CAUTS10) 32.8' track and rail system**9991.95**

UTS-10F Dolly Track System (Mfr # 99132986 • B&H # CAUTS10F) 32.8' track and rail system. Includes two flight cases.....**11,864.95**

UTS-15 Dolly Track System (Mfr # 99132983 • B&H # CAUTS15) 49.2' track and rail system**14,883.95**

UTS-15F Dolly Track System (Mfr # 99132987 • B&H # CAUTS15F) 49.2' track and rail system. Includes three flight cases.....**17,694.50**

VDP-15 Uni-Track Dolly (Mfr # 99132925 • B&H # CAVDP15) For use with Uni-Track dolly tracks**2198.50**

VPS-962 Low Ball Unit (Mfr # 99132962 • B&H # CAVPS962) A low-position camera mount for the VPD-15 Dolly.....**457.95**

DV FLUID HEADS

Action Pro

Lightweight and compact, the Action Pro offers true fluid drag and professional features for sophisticated digital camcorders weighing up to 13 lbs. It features Cartoni's patented, award-winning fluid drag modules both in pan and tilt and a double spring counterbalance module including "0" spring setting. The Action Pro head comes equipped with quick release sliding camera plate, orientable pan bar, positive locking pan and tilt movements and spirit level. A sturdy lightweight tripod with 75mm bowl, mid-level spreader and orientable rubber feet completes the system. For additional creativity, add a third axis to the Action Pro with the optional DigiDutch. This smart accessory allows you to shoot fantastic "Dutch angles". The DigiDutch attaches to the sliding camera plate with the simple 3/8" screw and supports the camera on a larger sliding base plate, allowing lateral centering.

AP10 Action Pro Fluid Head (Mfr # AP10 • B&H # CAAP10)

75mm ball base. Supports 12 lbs. Includes a telescopic pan bar and a camera mounting plate.....**699.95**

AP11 Action Pro Mini DV Head (Mfr # AP11 • B&H # CAAP11)

75mm Ball Base. Supports 6 lbs. Includes a telescopic pan bar and a camera mounting plate.....**599.95**



Payload Capacity	11 lbs.
Weight	2.8 lbs.
Pan Range	360°
Tilt Range	-85°/+90°
Countebalance	1+0
Fluid Drag	Continuous
Bowl Diameter	75mm

Action Pro Systems:

Action Pro Aluminum Tripod System (Mfr # APRO • B&H # CAAP)

System includes Action Pro Fluid Head with pan bar, quick release plate, Action Pro single-stage aluminum tripod with mid-level spreader, and soft carrying case**978.50**

Action Pro DV Aluminum Tripod System (Mfr # APDV • B&H # CAAPDV):

Includes Action Pro Mini DV head with pan bar, quick-release plate, Action Pro single-stage aluminum tripod with mid-level spreader, and soft carrying case**969.95**



Payload Capacity	11 lbs.
Weight	3.7 lbs.
Pan Range	360°
Tilt Range	±90°
Countebalance	Continuous
Fluid Drag	Continuous
Bowl Diameter	75mm

HiDV

The HiDV fluid head is the ideal support for DV cameras weighing up to 11 lbs. Extremely compact and lightweight the HiDV features extra smooth, continuously variable true fluid damping system on both pan and tilt movements and a patented continuously variable counterbalance for perfect finger-tip camera control. The HiDV's tilting angle is ±90° with perfect response throughout the entire tilt range. It interfaces with all 75mm bowl base tripods and supports. The extreme ruggedness and versatility together with a superb quality/price ratio make the HiDV the best possible support for DV videographers. The head comes equipped with a quick release sliding camera plate, illuminated spirit level and orientable pan bar. Dual pan arm rosettes for left- or two-handed configurations.

HiDV Fluid Head (Mfr # H100 • B&H # CAH100)

75mm ball base. Supports 10 lbs**809.95**

HiDV Systems:

HiDV 1-Stage Tripod System (Mfr # H101 • B&H # CAH101)

System includes HiDV fluid head, 1-stage aluminum alloy tripod, mid-level spreader, rubber feet, and soft case**1149.95**

HiDV 2-Stage Tripod System (Mfr # H102 • B&H # CAH102)

System includes HiDV fluid head, 2-stage aluminum alloy tripod, mid-level spreader, rubber feet, and soft case**1349.95**

CARTONI

DV FLUID HEADS

Focus

The Focus fluid head is the ideal support for DV camcorders weighing from 2.2 to 22 lbs. Extremely compact and lightweight, the innovative Focus head features a continuously variable fluid damping system on both pan and tilt movements and a unprecedented patented variable counterbalance which brings its range of use to cover all existing ENG and DV cameras.

The head comes equipped with a quick release sliding camera plate, illuminated spirit level and orientable pan bar. Its tilting angle is $\pm 90^\circ$ with perfect response throughout the entire tilt range. It interfaces with all 100mm bowl base tripods and supports. The extreme ruggedness and versatility together with an outstanding quality/price ratio make the Focus head ideal for news operators and DV videographers.

F100 Focus DV Fluid Head (Mfr # F100 • B&H # CAF100)

Includes A500 camera mounting plate and B464 telescoping pan arm.....**899.95**



Payload Capacity	22 lbs.
Weight	4.4 lbs.
Pan Range	360°
Tilt Range	$\pm 90^\circ$
Counterbalance	Continuous
Fluid Drag	Continuous
Bowl Diameter	100mm

Focus Systems: Each with F100 Focus Head, Mid-Level Spreader, Soft Carrying Case, and...

With A302 A/B Aluminum Ultralight 1-Stage Tripod (Mfr # F101 • B&H # CAF101).....**1399.95**

With L501 Aluminum 2-Stage ENG Tripod (Mfr # F104 • B&H # CAF104)**2199.95**

With A627 A/B Aluminum Ultralight 2-Stage Tripod (Mfr # F102 • B&H # CAF102).....**1599.95**

With L506 Aluminum Smart Stop 2-Stage ENG Tripod (Mfr # F106 • B&H # CAF106)**2349.95**

With A303 A/B Carbon Fiber Ultralight 1-Stage Tripod (Mfr # F103 • B&H # CAF103)**1574.95**



Laser: The magnesium and aluminum alloy Laser is a very compact, lightweight fluid head designed for portable cameras and camcorders up to 25 lbs. Featuring an infinitely variable counterbalance, the Laser provides for excellent performances at any tilt position from $\pm 90^\circ$. The continuously variable fluid control system ensures consistent drag levels and smooth camera movements on both pan and tilt modes. The Laser comes with a 100mm bowl base, telescopic pan bar and illuminated spirit level.

Z100 Laser ENG Fluid Head (Mfr # Z100 • B&H # CAZ100)

100mm ball base. Supports 22 lbs. Includes mounting plate and telescoping pan arm.....**2099.95**

Model	Payload Capacity	Weight	Pan Range	Tilt Range	Counterbalance	Fluid Drag	Bowl Diameter
Laser	25 lbs.	7 lbs.	360°	$\pm 90^\circ$	Continuous	Continuous	100mm

Laser Systems: Each with Z100 Laser Head, Mid-Level Spreader (or ground spreader when noted), and a Soft Carrying Case), and...

With A302 aluminum Ultralight tripod (Mfr # Z101 • B&H # CAZ101).....**2599.95**

With L503 tripod, on-ground spreader (Mfr # Z108 • B&H # CAZ108).....**3606.95**

With A303 Ultralight CF tripod (Mfr # Z102 • B&H # CAZ102)**2799.95**

With L504 carbon fiber 2-stage tripod (Mfr # Z109 • B&H # CAZ109).....**3827.95**

With L501 aluminum 1-stage tripod (Mfr # Z103 • B&H # CAZ103).....**2899.95**

With L504 tripod, on-ground spreader (Mfr # Z110 • B&H # CAZ110)**4146.95**

With L501 tripod, on-ground spreader (Mfr # Z104 • B&H # CAZ104)**3289.95**

With L506 aluminum Smart Stop 2-stage ENG tripod (Mfr # Z111 • B&H # CAZ111)**2899.95**

With L502 aluminum 2-stage tripod (Mfr # Z105 • B&H # CAZ105).....**3258.95**

With L507 aluminum Smart Stop 2-stage ENG tripod (Mfr # Z112 • B&H # CAZ112)**3616.95**

With L502 Tripod, on-ground spreader (Mfr # Z106 • B&H # CAZ106).....**3199.95**

With L503 carbon fiber 1-stage tripod (Mfr # Z107 • B&H # CAZ107)**3503.95**



ENG/EFP FLUID HEADS

Gamma 100mm ENG Fluid Head

Safe and reliable, the Gamma fluid head is specifically designed for ENG configurations up to 35 lbs. Featuring an infinitely variable counterbalance system with easy readable numerical reference, the Gamma provides excellent performances at any angle from +90 to -70°. Patented fluid dampening system ensures consistent drag levels and smooth camera movements throughout the range, allowing perfect reproduction of 10 basic tension settings, plus 30 intermediate positions in both Pan and Tilt modes. Other advanced features including camera quick release system and illuminated spirit level make this fluid head top in its class. Comes with 100mm sliding platform with quick-release, or an integrated sliding camera base plate with safety lock for additional tilt matching the -90° angle.



Gamma 100mm EFP Fluid Head
(Mfr # G100 - B&H # CAG100).....**3199.95**

Gamma Systems: Each with G100 Gamma Head, Soft Carrying Case, and...

Model	Tripod	Stage	Spreader	B&H SKU	Price
G101	Aluminum	1	Mid-level	CAG101	3859.95
G102	Aluminum	1	Ground	CAG102	4109.95
G103	Aluminum	2	Mid-level	CAG103	4339.95
G104	Aluminum	2	Ground	CAG104	4428.95
G105	Carbon Fiber	1	Mid-level	CAG105	4636.95
G106	Carbon Fiber	1	Ground	CAG106	4687.95
G107	Carbon Fiber	2	Mid-level	CAG107	5044.95

Model	Tripod	Stage	Spreader	B&H SKU	Price
G108	Carbon Fiber	2	Ground	CAG108	4839.95
G109	Heavy-Duty Aluminum	1	Ground	CAG109	4539.95
G110	Heavy-Duty Aluminum	2	Ground	CAG110	4838.50
G112	Heavy-Duty CF	1	Ground	CAG112	5152.95
G113	Heavy-Duty CF	2	Ground	CAG113	5664.95
G115	Aluminum Smart Stop	2	Multi-level	CAG115	4624.95
G116	CF Smart Stop	2	Multi-level	CAG116	5264.95

Head	Payload Capacity	Weight	Pan Range	Tilt Range	Counterbalance	Fluid Drag	Bowl Diameter
Gamma	35 lbs.	7.7 lbs.	360°	±90° with sliding plate	Continuous	Continuous	100mm
Delta	35 lbs.	7.7 lbs.	360°	±90° with sliding plate	Continuous	Continuous	100mm



Delta 100mm EFP Fluid Head
(Mfr # D600; B&H # CAD600)**4202.50**

Delta 100mm EFP Fluid Head

Ideal for supporting ENG dockable camcorders or EFP cameras equipped with long focal lenses and top mounted viewfinders, the Delta is manufactured with an extensive use of ultra-light magnesium alloy. The fully variable counterbalance system accommodates offset payloads of 18-48 lbs. ensuring excellent performances at any tilt angle. The Delta features a continuously adjustable fluid damping mechanism providing extremely smooth and precise camera movements. Standard performances of +70, -60°, with the European style quick attachment camera plate, can be increased to ±90° with the optional sliding base plate. Powered by a 9v battery, two digital displays indicate the counterbalance and tilt drag values, while an illuminated spirit level allows easy set-up even in low light conditions.

Delta Systems: Each with D600 Delta Head, Soft Carrying Case, and...

Model	Tripod	Stage	Spreader	B&H SKU	Price
D601	Aluminum	1	Mid-level	CAD601	4999.95
D602	Aluminum	1	Ground	CAD602	5099.95
D603	Aluminum	2	Ground	CAD603	5279.95
D604	Carbon Fiber	1	Mid-level	CAD604	5279.95
D605	Carbon Fiber	1	Ground	CAD605	5299.95
D606	Carbon Fiber	2	Ground	CAD606	4579.95
D607	Heavy-Duty Aluminum	1	Ground	CAD607	5599.95

Model	Tripod	Stage	Spreader	B&H SKU	Price
D608	Heavy-Duty Aluminum	2	Ground	CAD608	5199.95
D609	Heavy-Duty CF	1	Ground	CAD609	6273.95
D610	Heavy-Duty CF	2	Ground	CAD610	6599.95
D611	Carbon Fiber	2	Mid-level	CAD611	5897.50
D612	Aluminum	2	Mid-level	CAD612	4999.95
D613	Aluminum Safe Stop	2	Multi-level	CAD613	5484.95
D614	CF Safe Stop	2	Multi-level	CAD614	6124.95

CARTONI

EFP/STUDIO FLUID HEADS

C20S EFP Fluid Head

Designed to provide an extremely stable support for standard EFP configurations, the C20S operates with a wide range of cameras weighing from 15 to 66 lbs. The C20S features three award-winning fluid damping modules assuring outstanding drag levels and extraordinary smoothness in both pan and tilt modes. Movements can be selected with 7 precisely repeatable steps of drag, while free wheeling is available by simply setting the drag selector ring into position "0". Counterbalance is activated by an easy grip selector in 7 progressive steps and "0". The C20S comes with a 100mm bowl base, illuminated spirit level and two telescopic pan bars. A 150mm bowl base is also available as an option.



C20S EFP Fluid Head
(Mfr # S422 • B&H # CAS422)CALL

C20S Systems: Each with C20S Head, Ground Spreader, 2 Expandable Pan Bars, and...

With 1-stage heavy-duty aluminum tripod (Mfr # S421 • B&H # CAS421)**6569.95**
With 2-stage heavy-duty aluminum tripod (Mfr # S519 • B&H # CAS519)**6799.95**

With 1-stage heavy-duty CF tripod (Mfr # S423 • B&H # CAS423)**7432.50**
With 2-stage heavy-duty CF tripod (Mfr # S424 • B&H # CAS424)**7869.95**



C40S

C40S Film/Studio Head • C60S Studio/OB Head

The C40S is a heavy-duty fluid action head designed to support film and studio cameras weighing up to 88 lbs. Counterbalance mechanism is activated by an 8-position easy grip selector, while the fluid control system allows damping levels from "0" for free wheeling to 7 for maximum drag on pan and tilt modes. Standard features include the quick-release camera plate with safety lock, two adaptable telescopic pan bars and illuminated spirit level. The head comes equipped with a flat Mitchell base, and options include a 150mm bowl base and the eye piece extension holder. For Studio/OB configurations up to 110 lbs., the C60S head offers an extremely cost-effective option. The C40S and C60S interface directly with the Studio or Heavy Duty Series tripods.



C60S

C40S Film/Studio Head (Mfr # K479 • B&H # CAK479): Includes mounting plate and telescoping pan arm**6898.95**
C60S Studio/OB Head (Mfr # K600 • B&H # CAK600): Includes dovetail plate and 2 telescoping pan arms.....**7694.95**

C40S Systems: Each with C40S Head, On-Ground Spreader, and...

With K-701 heavy-duty 1-stage aluminum tripod
(Mfr # K478 • B&H # CAK478).....**9699.95**

With K-702 heavy-duty 2-stage aluminum tripod
(Mfr # K480 • B&H # CAK480).....**9849.95**

With K-703 heavy-duty 1-stage aluminum tripod
(Mfr # K477 • B&H # CAK477).....**9999.95**

With K-704 heavy-duty 2-stage aluminum tripod
(Mfr # K471 • B&H # CAK471).....**10,199.95**

C20S • C40S Dutch Heads: Available for the C20S and C40S, Dutch Heads add a 3rd axis, allowing lateral movement called "Dutch angle", which enhances special effects. Designed to make exceptionally smooth side-tilt effects simple and straightforward, Dutch Heads integrate the award-winning CARTONI fluid module in progression from "0" to 7 intensity. The counterbalance system features the 7 step spring mechanism. The heads interface directly with the quick release plate on the top of the C20S or 40S and with the same size camera plate to attach the camera assembly. A special telescopic pan bar completes the equipment.



C20S Dutch Head
(Mfr # S518 • B&H # CAS518)**4142.95**

C40S Dutch Head
(Mfr # S500 • B&H # CAS500)**5302.95**

Head	Capacity	Weight	Pan Range	Tilt Range	Counterbalance	Fluid Drag	Bowl Diameter
C20S	66 lbs.	14 lbs.	360°	+/-65°	7 Steps + 0	7+7	100/150mm
C40S	88 lbs.	24 lbs.	360°	+/-65°	7 Steps + 0	7+7	Flat Mitchell/150mm
C60S	110 lbs.	24 lbs.	360°	+/-65°	7 Steps + 0	7+7	Flat Mitchell/150mm
C20S Dutch	55 lbs.	11 lbs.	—	+/-65°	7 Steps + 0	7+0	—
C40S Dutch	100 lbs.	17 lbs.	—	+/-65°	7 Steps + 0	7+0	—

STUDIO/OB FLUID HEADS

Master Fluid Head

Designed to support cameras weighing from 22 lbs. to 66 lbs., the Master head combines a wide range of counterbalance capabilities with an outstanding fluid damping system. The frictionless variable fluid modules perform a wide variety of fluid drag allowing smooth and precise movements in any shooting situation. The new patented counterbalance system supports a wide range of payloads at any angle throughout the $\pm 90^\circ$ tilt angle.

All operating knobs and levers are conveniently located and easy to reach with a special care for ergonomics. The head comes equipped with two telescopic pan bars, illuminated spirit level and digital readouts for drag and counterbalance settings.



Master Fluid Head (Mfr # M530 • B&H # CAM530): Includes a wedge plate and two telescoping pan arms.....**7218.95**

Master Systems: Each with Master Fluid Head, Studio Ground Spreader, and...

With 1-stage aluminum Studio tripod and 2 extendable pan bars
(Mfr # M110 • B&H # CAM110).....**9007.95**

With 2-stage aluminum Studio tripod and 2 extendable pan bars
(Mfr # M111 • B&H # CAM111).....**9182.95**

With 2-stage carbon fiber Studio tripod and 2 extendable pan bars
(Mfr # M112 • B&H # CAM112).....**10,237.95**

With 1-stage aluminum Studio tripod and eye piece holder
(Mfr # M113 • B&H # CAM113).....**9007.95**

With 2-stage aluminum Studio tripod and eye piece holder
(Mfr # M114 • B&H # CAM114).....**9406.95**

With 2-stage carbon fiber Studio tripod and eye piece holder
(Mfr # M115 • B&H # CAM115).....**10,232.95**

Head	Payload Capacity	Weight	Pan Range	Tilt Range	Counterbalance	Fluid Drag	Bowl Diameter
Master	66 lbs.	14 lbs.	360°	+/-90°	Continuous	Continuous	Flat Mitchell/150mm



Sigma Fluid Head

Designed to support cameras from 22 lbs. to 88 lbs., the Sigma head combines a wide range of counterbalance capabilities with an outstanding fluid damping system. The frictionless variable fluid modules perform a wide variety of fluid drag allowing smooth and precise movements in any shooting situation. The patented counterbalance system supports a wide range of payloads at any angle throughout the $\pm 90^\circ$ tilt angle. All operating knobs and levers are conveniently located and easy to reach with a special care for ergonomics.

Sigma Broadcast Fluid Head (Mfr # S100 • B&H # CAS100)
Equipped with two telescopic pan bars, illuminated spirit level and digital readouts for drag and counterbalance settings.....**7859.95**

Sigma Film/Digital Fluid Head (Mfr # S101 • B&H # CAS101)
Supplied with one telescopic pan bar, one front small pan handle and the eye piece extension holder.....**7754.95**

Sigma Systems:

With Sigma Broadcast Head, 1-stage Superpod and an HD ground spreader (Mfr # S105 • B&H # CAS105).....**9,583.95**

With Sigma Film/Digital Head, 1-stage Superpod and an HD ground spreader (Mfr # S107 • B&H # CAS107).....**9,583.95**

With Sigma Broadcast Head, 1-stage Superpod, mid-level spreader and foot pads (Mfr # S120 • B&H # CAS120).....**10,368.95**

With Sigma Film/Digital Head, 1-stage Superpod, mid-level spreader and foot pads (Mfr # S121 • B&H # CAS121).....**10,368.95**

Head	Payload Capacity	Weight	Pan Range	Tilt Range	Counterbalance	Fluid Drag	Bowl Diameter
Sigma	88 lbs.	26 lbs.	360°	+/-90°	Continuous	Continuous	Flat Mitchell/150mm

STUDIO/FILM FLUID HEADS

Omega OB/Studio Fluid Head

Designed to support the latest Studio and OB cameras, the Omega is an extremely compact fluid head incorporating a highly precise patented counterbalance system as well as an advanced fluid damping module in both pan and tilt modes. The Omega counterbalance mechanism is ideal for camera configurations with a high center of gravity up to 176 lbs. giving a perfect response throughout the tilt range. All settings are connected with a digital read out. The camera is fixed on a V-shaped wedge plate according to international standards and the precise center of gravity is achieved by a fine tuning crank underneath the rear section of the sliding plate. The Omega OB/Studio Fluid Head interfaces directly with any flat Mitchell base or 150mm bowl base and can be mounted on top of all existing pedestals featuring the 4-hole bores. Weighs only 33 lbs., the Omega comes equipped with an integrated soft grip carrying handle, two telescopic pan bars, and illuminated spirit level.



Omega EFP Fluid Head (Mfr # O101; B&H # CAO101): Includes a dove tail wedge plate and two telescoping pan bars.....**9989.95**

Omega Systems:

With an Omega EFP Fluid Head, 1-stage Superpod flat base and an HD ground spreader (Mfr # O103 • B&H # CAO103).....**11,964.95**

With an Omega EFP Fluid Head, 1-stage Superpod flat base a mid-level spreader and foot pads (Mfr # O105 • B&H # CAO105).....**12,029.95**

Head	Payload Capacity	Weight	Pan Range	Tilt Range	Counterbalance	Fluid Drag	Bowl Diameter
Omega	176 lbs.	33 lbs.	360°	+/-65°	Continuous	Continuous	Flat Mitchell/150mm



Lambda Nodal Swing Head

The Lambda is a nodal swing head ideally suited for 35mm film cameras equipped with long lenses, mattebox and extra large film magazines. Providing a high level of operational flexibility, the Lambda can be easily fitted to a wide range of supports including tripods, dollies, cranes and camera cars. The mounting can be inverted in under-slung position for low line positioning and allow the camera to be moved all the way to the ground and provide for accurate images which normally cannot be obtained with other traditional supports.

The balance system is designed so that the camera may swing on its center of gravity and rotate 360° on its vertical axis. No springs or similar counter reaction elements are required to set the head in a fixed tilt position and fluid pan and tilt movements have the same identical feel. The lens focal distance can be kept constant by presetting the fore and aft horizontal sliding plate. The Lambda employs the patented Cartoni fluid drag control system on both pan and tilt modes. In order to obtain the 3rd axis rotation, the Lambda features the 3rd axis accessory comprising an additional fluid drag system with 7 steps + "0". A variety of accessories including orientable extendable pan bar, round steering wheel, short pan handle, 150mm bowl base, counterweights and rods for nodal setting complete the equipment.

Lambda Nodel Swing Head (Mfr # L100; B&H # CAL100): Includes a telescoping pan bar.....**13,414.50**

Head	Payload Capacity	Weight	Pan Range	Tilt Range	Counterbalance	Fluid Drag	Bowl Diameter
Lambda	88 lbs.	46 lbs.	360°	360°	—	7 + 7	Flat Mitchell/150mm

TRIPODS

A/B Lightweight Tripods

A/B ultra-light tripods combine superb torsional rigidity with the lowest possible weight. Rigidity is assured by two external 20mm diameter tubes reinforced by a central tube of 25mm, while a flip-clamping system with a safety lock ensures maximum clamping efficiency at any weight. Equipped with a 100mm bowl base, the A/B tripods operate with an expendable mid-level spreader and provide for a 44 lb. payload. Easy to handle and quick to set up, they interface perfectly with the Focus and Laser, fluids heads.

A/B Ultra-Light (Mfr # A302 • B&H # CAA302): 1-stage with mid-level spreader	568.95
A/B Aluminum Ultra-Light (Mfr # A627 • B&H # CAA627): 2-stage with mid-level spreader	629.95
A/B Carbon Fiber Ultra-Light (Mfr # A303 • B&H # CAA303): 1-stage with mid-level spreader	649.95



ENG Tripods

Available in strong tubular alloy or light carbon fiber, in both single or two-stage versions, these tripods incorporate an ultrafast and secure flip-clamping system. In the single stage version, torsional rigidity on each leg is assured by four 16mm diameter tubes connected to the 100mm leveling base with an internal mounted aluminum shaft. This system eliminates backlash and provides for outstanding stability in any shooting environment. In the two-stage version, higher rigidity is obtained by a combination of 16mm and 20mm diameter tubes. Ideal for the Focus, Laser, Gamma and Delta heads, they also interface with the expendable mid-level or the flexible ground spreader.

L501 (Mfr # L501; B&H # CAL501): 1-stage aluminum ENG tripod	714.95
L502 (Mfr # L502; B&H # CAL502): 2-stage aluminum ENG tripod	969.95
L503 (Mfr # L503; B&H # CAL503): 1-stage carbon fiber ENG tripod	1208.95
L504 (Mfr # L504; B&H # CAL504): 2-stage carbon fiber ENG tripod	1659.50

EFP Tripods

Featuring 20mm diameter tubes, the single stage aluminum or carbon fiber EFP tripods are fitted with a flip-clamping system and provide for an exceptional steady platform, with virtually no torquing and twisting problems. The 2-stage version, also available in extra strong tubular alloy or light carbon fiber construction, features a combination of 20/25mm diameter tubes, allowing heavier weights to be supported, as well as a greater operating height range. Equipped with a 100mm Bowl base, the standard EFP tripod is ideal for the DELTA and C20S heads.

H601 (Mfr # H601; B&H # CAH601): 1-stage aluminum heavy-duty tripod legs EFP tripod	999.95
H602 (Mfr # H602; B&H # CAH602): 2-stage aluminum heavy-duty tripod legs EFP tripod	1257.95
H603 (Mfr # H603; B&H # CAH603): 1-stage carbon fiber heavy-duty tripod legs EFP tripod	1688.50
H604 (Mfr # H604; B&H # CAH604): 2-stage carbon fiber heavy-duty tripod legs EFP tripod	2093.50



TRIPODS

Studio Tripods

Studio tripods are entirely manufactured in die-cast alloy and fitted with two rotary clamping mechanisms on each leg. The single stage version, equipped with 22mm diameter tubes, features unsurpassed torsional rigidity and structural integrity. It incorporates locking knobs with over tightening protection, ensuring that maximum clamping efficiency is maintained over the lifetime of the tripod. In the two-stage version, also available in light carbon fiber, higher rigidity is obtained with a combination of 22mm and 25mm diameter tubes. Designed for the C40S, C60S and Master, these tripods can be supplied with an interchangeable 150mm Bowl base or flat Mitchell base.

K701 (Mfr # K701; B&H # CAK701): 1-stage aluminum flat base tripod legs.....	1204.95
K702 (Mfr # K702; B&H # CAK702): 2-stage aluminum flat base tripod legs.....	1419.95
K703 (Mfr # K703; B&H # CAK703): 1-stage carbon fiber flat base tripod legs.....	1208.50
K704 (Mfr # K704; B&H # CAK704): 2-stage carbon fiber flat base tripod legs.....	2093.50
K711 (Mfr # K711; B&H # CAK711): 2-stage carbon fiber flat base tripod legs	2289.50



Baby Legs

Low-level versions of the ENG, EFP and Studio tripods are available for low-level shots.

L505 (Mfr # L505 • B&H # CAL505): 1-stage Baby tripod legs (100mm bowl) supports 132 lbs.....	689.95
H605 (Mfr # H605 • B&H # CAH605): 1-stage heavy-duty Baby tripod legs (100mm bowl) supports 176 lbs.....	818.95
K705 (Mfr # K705 • B&H # CAK705): 1-stage heavy-duty Baby tripod legs (Flat base) supports 330 lbs.....	1029.95
K710 (Mfr # K710 • B&H # CAK710): 1-stage heavy-duty Baby tripod legs (150mm bowl) supports 330 lbs.....	1041.95

K625 3-Way Leveller HD Tripod

The K625 is a unique heavy duty tripod with flat Mitchell base and 3-way levelling ability for horizontal fine tuning. The innovative concept allows mounting all flat Mitchell base heads and still be able to correct horizontal plan without acting on the legs height and without compromise for torsional rigidity. Double-tube, one-stage alloy construction for unprecedented 440 lbs. carrying capacity. Double cine-style rotary leg clamps ensure absolute support integrity.

K625 (Mfr # K625 • B&H # CAK625).....	818.95
--	---------------

Elevation Unit

An elevation unit is available for the K625, giving it the height range advantages of a standard pedestal with the low cost, robustness and fast operation of a tripod. Weighing only 4.4 lbs., it features a maximum elevation height of 14" and can be easily mounted on any existing platform equipped with the 4-holes bore.

E881 Elevation Unit: Supports up to 220 lbs. (Mfr# E881 • B&H# CAE881)	1377.50
---	----------------



PEDESTALS

P20 Pneumatic Pedestal

Extremely compact and lightweight, the P20 is the perfect solution for mobile work and light-weight studio needs. Supporting up to 55 lbs., the innovative square shaped design pneumatic column provides maximum stability, smoothness and jerk-free operation. The manual adjusting system allows your camera to move smoothly and effortlessly, which helps achieve the perfect shot every time. The P20 also folds down for quick and easy transport.

The pedestal is anchored by a square shaped pneumatic system. The system works on the principle of compressed air, which acts as a counterweight. This allows for quick and easy height adjustment. Allows 15.7" on-shot stroke, making sure you achieve the shot you need.

Includes an air pressure gauge, locking brake and safety air pressure valve adjusted at maximum 187 psi. The air pressure inside the column can be set in manually and adjusted to suit the exact weight of the camera configuration. The foldable dolly features a six-position track lock foot operated brake on each of the 100mm wheels and cable guards to prevent any wires from tangling around the axles. Includes a manual air pump.

P20 (Mfr # P20 • B&H # CAP20)
Pedestal with 100mm ball base adapter**5699.95**

P20 (Mfr # P2L01 • B&H # CAP20LK)
With Z100 Laser fluid head and two pan bars.....**7899.95**

P20 (Mfr # P2D201 • B&H # CAP2D201)
With Delta Fluid head and two pan bars.....**10,158.95**

P20 (Mfr # P2G01 • B&H # CAP2G01)
With Gamma Fluid head and two pan bars.....**9377.95**



P50 & P70 Pneumatic Pedestals

The P50 is a portable and compact system for both studio and OB applications. Extremely stable yet lightweight, its ideal performance is reached with camera/lens combination of around 100 lbs. In the P70 version, the payload capacity is extended to 145 lbs. They allow 19.7" on-shot stroke, making sure you achieve the shot you need.

The air filled, one shot column is fast and safe to operate: the air can be set in manually or by compressor, and a safety air pressure valve prevents danger of over pumping. The innovative column design provides outstanding stability and jerk-free control with exceptional smoothness and precise movements. Accurate camera balance is achieved at full extension by simply activating the bleed valve, releasing excess air pressure. The column supports a maximum payload of 121 lbs. at 180 psi and the safety valve is adjusted at maximum 250 psi.

Six position track lock, foot operated brake on each of the 125mm twin wheels and cable guards provide smooth movements in any desired direction. The column is firmly secured to the dolly by a double clamp, easily engaged by two ergonomic locking levers. The dolly is foldable for easy transport. A set of 4.5" pneumatic tires with wheel brakes are available for OB use.

P50 With 100mm ball base adapter (Mfr # P500 • B&H # CAP50)**9901.95**
150mm Ball Base Adapter for the P50 (Mfr # P150 • B&H # CAP150)**263.50**

P70 With 100mm ball base adapter (Mfr # P700 • B&H # CAP700).....**10,363.95**

Hand pump for P50 Pedestal (Mfr # P866 • B&H # CAP866)**48.95**

Foot Ring for P50 Pedestal (Mfr # P867 • B&H # CAP867)**188.95**

P50 and P70 Systems with Head and Two Pan Bars

P50 with Delta head (Mfr # P5D01 • B&H # CAP5D01).....**14,579.95**
P50 with C20S head (Mfr # P5C01 • B&H # CAP5C01)**16,402.95**
P50 with Master fluid head (Mfr # P5MA1 • B&H # CAP5MA1)**17,247.95**
P50 with Sigma fluid head (Mfr # P5S01SIGMA • B&H # CAP5S01Q).....**17,843.50**
P50 with C40S fluid head (Mfr # P5K01 • B&H # CAP5K01)**17,498.50**

P70 with Master fluid head (Mfr # P7MA1 • B&H # CAP7MA1).....**17,319.95**

P70 with Omega fluid head (Mfr # P7OM1 • B&H # CAP7OM1).....**17,284.95**

P70 with Sigma fluid head (Mfr # P7SI1 • B&H # CAP7SI1)**18,669.95**

P70 with C60S fluid head (Mfr # P7C61 • B&H # CAP7C61).....**18,268.95**

PEDESTALS

P90 Pneumatic 2-Stage Pedestal

Extremely versatile, the two-stage P90 is designed to support camera/lens combinations up to 198 lbs. covering the entire range of studio and OB configurations. The system is compact and portable, the 2 stage column performs an on-shot stroke of 77 cm with a smooth and precise movement. The sturdy and yet lightweight dolly is equipped with high precision double wheels interlocked by a special designed chain allowing accurate travelling and steering, even on-shot. The crab position is also available for narrow door ways. All operating devices and control display are at the cameramen easy access. The pneumatic column works on simple compressed air which can be loaded with a compressor or a simple hand pump. The piston innovative design avoids complicated balance setting and no counterweights are needed. The system interfaces with all flat base, 4-bore holes heads or any other bowl based head with an adapter.

- P90** Pedestal with flat base adapter (Mfr # P900 • B&H # CAP900) **20,924.95**
- P90** Pedestal with Sigma fluid head and dual pan bars (Mfr # P90S11 • B&H # CAP90SK) **25,949.95**
- P90** Pedestal with Master fluid head and dual pan bars (Mfr # P900 • B&H # CAP900) **28,359.50**
- P90** Pedestal with C60S fluid head and dual pan bars (Mfr # P90C61 • B&H # CAP90C61) **28,809.95**
- P90** Pedestal with Omega fluid head and dual pan bars (Mfr # P90OM1 • B&H # CAP90OM1) **31,629.95**

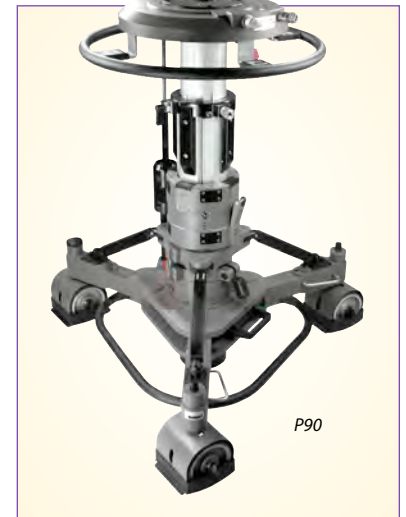

	P20	P50	P70	P90
Maximum Pressure	187 psi	250 psi	175 psi	187 psi
Maximum Capacity	55 lbs.	121 lbs.	145 lbs.	198 lbs.
Total Weight	31 lbs.	62 lbs.	62 lbs.	110 lbs.
"On-shot" Stroke	15.7"	19.7"	19.7"	30.3"
Steering Wheel Diameter	10.2"	17.7"	17.7"	22.6"
Min. / Max. Height	29" / 63.3"	30" / 55.1"	30" / 55.1"	25.9" / 56.2"
Wheels	3 x 2 coupled	3 x 2 coupled	3 x 2 coupled	—
Wheels Diameter	3.9"	4.5"	4.5"	49.2"
Doorway Tracking Width Min.	26.3"	39.4"	39.4"	31.4"
Doorway Tracking Width Max.	38.1"	39.4"	39.4"	31.4"

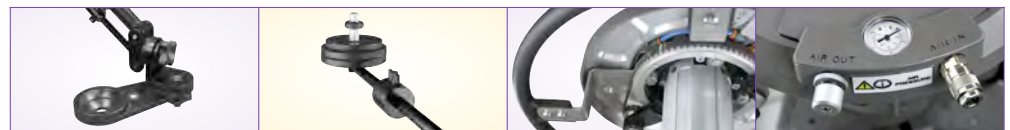

DV Mini Jib

Designed to carry up to 22 lbs. the Cartoni Jib is one of the most versatile and cost effective lightweight portable jibs around.

Assembled in less than five minutes the Jib adds the benefit of diagonal tracking and elevation to the traditional pan and tilt movement of a standard fluid head. The Jib weighs only 20 lbs., folds down to 39" in length and permits shooting from absolute ground level to 78" in height. The rear part of the arm, which holds the counterweights, is extendible to provide for accurate camera balance, while the front telescopic arm allows the Jib to work in wide variety of shooting requirements. Standard configuration includes a 100mm bowl base head attachment with double orientation, left to right and on/ under, spirit level and 22 lb. counterweights. The Jib interfaces with any 100mm bowl base tripod.

- M100** (Mfr # M100 • B&H # CAM100): Portable Mini Jib Arm with Weights **1,699.95**

ACCESSORIES

SPREADERS

1-Stage Multi-Level Above-Ground

Spreader (Mfr # P730-1; B&H # CAP7301):

A lightweight telescopic mid-level spreader that allows a quick set up, and adds just 1.1 lbs to your tripod. Its quick release attachment installs in just a few seconds**369.95**

2-Stage Multi-Level Above-Ground

Spreader (Mfr # P730-2; B&H # CAP7302):

Similar to the above spreader, but 2-stage**369.95**

Mid-Level Spreader (Mfr # P731; B&H # CAP731)

Suitable for fast moving ENG and EFP applications, this lightweight telescopic mid-level spreader adds only 1 lb. to your tripod and allows a very quick set-up. Its quick release attachment requires only a few seconds for being installed. Fits the A302, L501 and L503 single-stage tripods**253.50**

Mid-Level Spreader (Mfr # P732; B&H # CAP732)

Similar to the above spreader, but for the L502 and L504 two-stage tripods**253.50**

Metal Ground Spreader (Mfr # P733; B&H # CAP733)

Designed to enhance the stability of studio tripods, this spreader weighs 2.5 lbs, and attaches to the tripod foot with a rubber loop. Fits the K701, K702 and K711 tripods**369.95**

Flexible Ground Spreader (Mfr # P734; B&H # CAP734):

Designed for both ENG and EFP tripods and composed of rubber and nylon polymer material, this on-ground spreader provides outstanding flexibility on uneven field situations. Fits the H601, H602, H603 and H604 tripods**385.95**

Superpod Ground Spreader (Mfr # P735; B&H # CAP735):

Suitable for the K706 heavy-duty Studio tripod. A comfortable foot-operated pedal or rubber loops allow the tripod to firmly attach to the tripod foot**594.95**

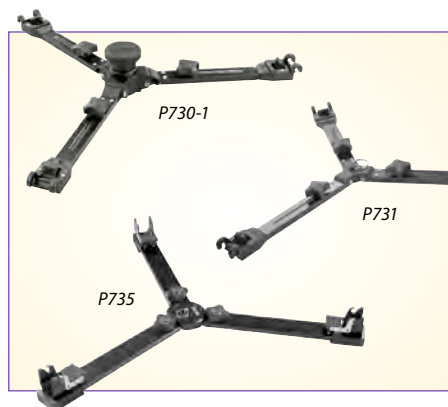

Studio Tripod Ground Spreader (Mfr # P736;

B&H # CAP736): A heavy-duty ground spreader designed for the C40. A foot-operated pedal or rubber loops allow the tripod to firmly be attached to the tripod foot**508.95**

Superpod Mid-Level Spreader (Mfr # P737; B&H # CAP737):

Provides structural reinforcement for Superpod tripods by preventing the legs from slipping outward**517.50**

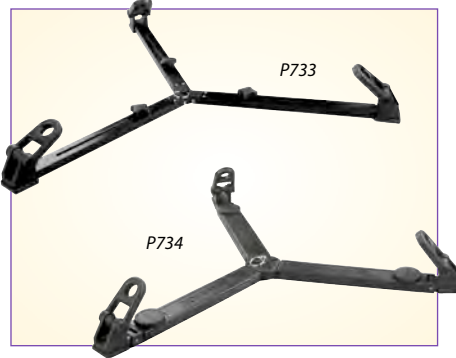

FOOT PADS

Foot Pads (Mfr # P865; B&H # CAP865)

Set of three adjustable pivoting foot pads for use with Cartoni Superpod tripods**333.95**



RUBBER FOOT

Used as replacements for the standard spiked tripod foot when you either want to work on delicate surfaces or need additional vibration absorption. Ideal on slippery and glossy floors.



Rubber Tripod Foot

(Mfr # B457; B&H # CAB457)**29.95**

Set of 3 Rubber Feet

(Mfr # B458 • B&H # CAB458)**79.95**

SHOULDER STRAPS

For DV Tripods (Mfr # A871; B&H # CAA871)**32.95**

For ENG Tripods (Mfr # G871; B&H # CAG871) ...**34.95**

DOLLIES

C491 Lightweight Dolly (Mfr # C491; B&H # CAC491)

Suitable for DV and three tube tripods, this 6.5 lbs. foldable dolly features independent track locks and wheel brakes. Load capacity 110 lbs. Fits the Action Pro and Ultralight tripods ..**529.95**

B419 Standard Dolly (Mfr # B419; B&H # CAB419)

Suitable for both ENG and EFP tripods, this 11 lb. foldable dolly is specifically designed for multi location work. It features a 6-position track lock on each wheel, cable guards, fast action foot operated brakes and 100mm wheel diameter. Load capacity is 220 lbs. Fits the L501, L502, L503 and L504 tripods**734.95**

S440 Studio Dolly (Mfr # S440; B&H # CAS440)

A rugged foldable dolly designed for studio operations. Features double wheels with cable guards, 6 position track lock and foot operated brakes. Load capacity is 440 lbs. Fits the H601, H602, H603 and H604 EFP tripods. The S440 weighs 25 lbs**1,374.95**

0736 Superpod Dolly (Mfr # 0736; B&H # CAO736)

A heavy-duty dolly for the Superpod**1419.95**



ACCESSORIES



Tie-Down Cups

- Tie down cups are the fastener which holds heads in place after leveling.
- For Action Pro, Focus and Gamma heads
(Mfr # B466 • B&H # CAB466).....**79.95**
 - For Delta and C20S
(Mfr # D514 • B&H # CAD514)**89.95**
 - For C40S Fluid Head
(Mfr # K481 • B&H # CAK481).....**99.95**
 - To hold the C40S head with a flat base in position on a tripod or pedestal
(Mfr # K489 • B&H # CAK489).....**59.50**
 - For Lambda head with a flat base (Mitchell) in position on a tripod or pedestal
(Mfr # L893 • B&H # CAL893)**82.50**



Pan Bars w/Handle Attachment

- For Action Pro Fluid head
(Mfr # AP05 • B&H # CAPB)**69.95**
- For Focus, Alfa, Beta and HiDV heads
(Mfr # B464 • B&H # CAB464)**174.95**
- For Laser and Gamma heads
(Mfr # G200 • B&H # CAG200).....**174.95**
- For Delta and C20S heads
(Mfr # D515 • B&H # CAD515)**229.95**
- For C40S head
(Mfr # K482 • B&H # CAK482)**279.95**
- For C40S Dutch head
(Mfr # K520 • B&H # CAK520)**289.95**
- For Omega head
(Mfr # O110 • B&H # CAO110)**296.50**
- For C20S Dutch head
(Mfr # S531 • B&H # CAS531).....**213.50**
- For Sigma head
(Mfr # S109 • B&H # CAS109).....**289.95**
- For Master head
(Mfr # M931 • B&H # CAM931)**213.95**

B410 Soft Carrying Tripod Case

Designed for the Alfa and Beta 2-stage tripods, it features 1/2" foam in the interior, two outside pockets, leather handles with Touch Fastener closure and shoulder strap.

(Mfr # B410; B&H # CAB410).....**149.95**



Hi-Hats, Bazooka Baskets, Base Adapters

Designed to provide stable support, the Hi Hat allows the mounting of a video fluid head to get great footage without shakes and vibrations at an extremely low camera angle. Available in a variety of different sizes - 75, 100, 150mm bowl and Mitchell base. It's ideal to mount it on a board or any other location where you need the use of a video head.

- 100mm Ball to Gitzo Flat Base Tripod**
(Mfr # B475; B&H # CAB475).....**214.95**
- 100mm Hi-Hat**
(Mfr # B476; B&H # CAB476)**214.95**
- Hi-Hat with Flat Base for C40S Fluid Head**
(Mfr # K487; B&H # CAK487)**229.95**
- 150mm Ball Base Hi-Hat**
(Mfr # K492; B&H # CAK492).....**229.95**
- 100mm to Flat Base Adapter**
(Mfr # S525; B&H # CAS525).....**199.95**
- 100mm to 150mm Ball Base Adapter**
(Mfr # S532; B&H # CAS532)**199.95**
- 150mm Ball Base to Flat Base Adapter** (Mfr # K462 • B&H # CAK462)**199.95**

Bazooka Baskets

Bazooka Baskets with 100mm or 150mm bowl allows impromptu camera setups with half-bowl fluid heads on the end of a sturdy post when shooting in confined spaces. Three set screws placed at 120° positions on the collar secure the post.

- 100mm Bazooka Basket (Mfr # D470 • B&H # CAD470)**209.95**
- 150mm Bazooka Basket (Mfr # D845 • B&H # CAD845)**259.95**
- Flat base Bazooka Basket (Mfr # D846 • B&H # CAD846).....**259.95**



Quick Release Plates (Repl.)

- For Action Pro, HiDV (Mfr # AP12 • B&H # CAAP12).....**64.95**
- For Focus, Alfa I, Alfa II, Action Pro (Mfr # A500 • B&H # CAA500)....**69.95**
- For Laser (Mfr # Z125 • B&H # CAZ125).....**89.95**
- For Beta, Gamma, Delta (Mfr # B511 • B&H # CAB511).....**114.95**
- For C20S, C40S, Sigma (Mfr # K512 • B&H # CAK512).....**126.50**
- Wedge plate for OB remote (Mfr # K498 • B&H # CAK498)**237.95**
- High Definition long plate (Mfr # H395 • B&H # CAH395).....**239.95**
- 1/4" Camera mount screw (Mfr # S914 • B&H # CAS914)**10.95**

ADVANTA-JIB LITE



Camera Crane System

The Advanta-Jib Lite is in a class by itself. Other camera jibs may cost less, but none will pack the features and value you'll find with the Advanta-Jib Lite. Similar jibs use cable-drive systems to pan and tilt. However, they can be cumbersome, time consuming to install and balance, and not very smooth. Because of their push/pull cable-drive system, friction increases with distance, making smooth pan/tilt starts difficult at greater jib lengths. The Advanta-Jib Lite's patented hydraulic tilt and open cable pan system allows for smooth pans and tilts at any height — giving you more freedom and flexibility—taking your productions to the level you've always dreamed of.

Designed for today's professional and independent videographer, the Advanta-Jib Lite offers unprecedented convenience and control at an

affordable price. If you're comfortable with a traditional tripod head, mastering the Advanta-Jib Lite is fast and easy. With Dykortech's patented technology, you have ultra-smooth control through a system of cables and hydraulics with camera pan and tilt/roll control located at the rear end of the jib.

FEATURES

- ◆ Complete camera crane system including 4' arm, hydraulic head and a remote control package. Ideal for compact cameras (10 lbs. or less), mounts to any tripod with 3/8" stud able to support the system weight.
- ◆ Patented hydraulic tilt and open cable pan system allows for smooth pans and tilts at any height.
- ◆ Pan and tilt at any height.
- ◆ Built-in mechanical pan and tilt/roll head (operated from jib rear).
- ◆ User friendly - pan-handle pan and tilt/roll operation.
- ◆ Remote operation is accomplished utilizing LANC/Panasonic protocols.
- ◆ Quick assembly and disassembly.
- ◆ Lightweight for easy transport and set-up.
- ◆ Standard jib weighs only 16 lbs.
- ◆ Camera can be mounted over and under-slung for various production applications.
- ◆ C/W jib boom lock, jib pan lock, camera tilt lock.
- ◆ No tripod head required.
- ◆ Superior, durable construction.
- ◆ Matte black finish minimizes reflection.



Advanta-Jib Lite (Mfr # ADVANTA-JIB LITE • B&H # DYAJL4)

Includes Pan Tilt and Roll Head, Fulcrum, Panhandle Weight Bar, three Cam CB Springs, Leveling Bar and Cable, Video and LANC/Panasonic Remote Extensions, LCD Monitor Mount, and Quick Release Sliding Camera Shoe.....**1998.95**

Underslung Head (Mfr # UNDERSLUNG HEAD • B&H # DYUH)

Allows the camera to be mounted under the jib. This creates a low angle advantage reaching lower levels of perspective while increasing the tilt angle to 160°. This head will work with the same pan and tilt controls as the regular head.....**258.95**

Tail Extension (Mfr # TAIL EXTENSION • B&H # DYTE)

Extends tail section by 10" to reduce the amount of counterweight required to counterbalance the jib arm when front extensions are added. It comes with the appropriate cables and connections.....**198.95**

Real Dirty Extension (Mfr # REAL DIRTY EXTENSION • B&H # DYRDE3)

3' extension kit, works with the Dirty Extension allowing a 10' reach. It comes with cables and connections**198.95**

Dirty Extension (Mfr # DIRTY EXTENSION • B&H # DYDE3)

3' extension kit, extends jib to 7' reach. It comes with the appropriate cables and connections.....**198.95**

Jib Bag (Mfr # JIB BAG • B&H # DYJB)

Convenient soft lightweight case for transporting jib**54.95**

Short Pan Handle (Mfr # SHORT PAN HANDLE • B&H # DYSPH)

For use in tight operating locations**24.95**

LEVELING TRIPDODS

Gitzo's leveling tripods have a ball joint-mounted center column designed to let you get your camera perfectly level simply by adjusting column inclination instead of having to set each leg individually. In addition, leveling tripods have all the features and benefits of the Gitzo Mountaineer carbon fiber range.

All-purpose tripods, they are leveled instantly with the simple twist of a knob, making them perfect for shooting on uneven terrain. Features include a silky-smooth rapid center column that's grooved to prevent rotation, a stainless steel weight hook for added stability, a removable spirit level at the center column base, and ergonomic rubber grip locks for easy handling. Up to 30% lighter than an equivalent aluminum tripod yet it does not compromise on strength, torsional stability or durability.

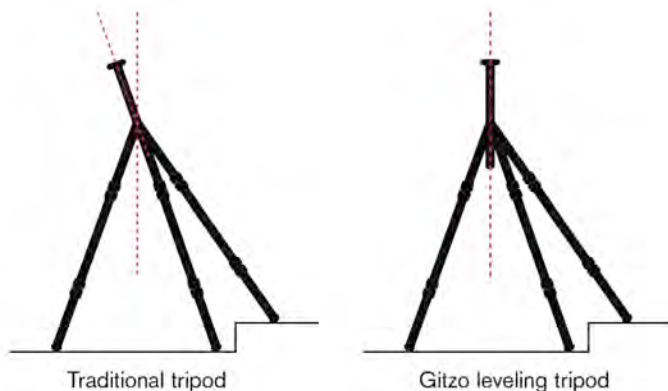

- ◆ Their column ($\pm 12^\circ$) lets you set your camera perfectly level without adjustment of the tripod legs, and keeps your equipment closer to the vertical of the tripod's center of gravity for more stable shooting on uneven terrain.
- ◆ Open the tripod, leaving the center column down. Loosen the leveling system locking knob. Adjust the center column inclination to get it level; for reference use the built-in bubble spirit level. When the column is correctly leveled, tighten the locking knob. Slide the center column to the required height.
- ◆ Constructed using a dual "screw thread and glue" jointing technology which provides greater durability and reliability.
- ◆ The center column locking collar above the shoulder makes it easy to move the column up and down. The rapid column can easily be inverted for an alternative shooting angle or low level macro work.
- ◆ Fitted with sliding stops, which enable the legs to be individually set at different angles, providing more flexibility and permitting very low angle shooting.
- ◆ Telescopic leg extensions and center columns are fitted with anti-slippage rubber cushioned locking rings.



G1380 Fluid Head (Mfr # G1380 • B&H # GIG1380)

A professional fluid video head designed for today's lightweight DV, DVCAM and HDV cameras. The head features perfect balancing system, variable fluid drag control on pan and tilt movements for smooth repeatable actions, separate pan and tilt locks. Innovative and unique interchangeable spring balance mechanism allows the use of a variety of camcorders with different payloads. The counterbalance system is adjustable with 6 interchangeable springs to cover cameras weighing from 2-23 lbs**999.95**

Davis & Sanford

Pro Vista Video Tripod with FM18 Head and W3 Dolly with 3" Rubber Wheels

Perfect for field, educational or industrial applications, the Pro Vista is a heavy-duty double strut 3-section tripod and fluid head. Features include self-aligning metal quick-flip leg locks for fast set up. Included mid-level spreader adds additional support. Rubber feet grab any surface. Non-glare black anodized finish. The 75mm FM18 fluid head has an 18 lb. capacity and sliding quick release plate system for variable balance control. Two adjustable removable pan handles provide easy maneuverability, and independent tilt & pan adjustment/locks deliver effortless control. Also has bubble level for easy leveling. (Mfr # PROVISTA7518 • B&H # DAPVT75)**199.95**



	Column Type	Leg Sections	Max. Height with Extended Center Column	Max. Height Column Down	Minimum Height	Closed Height	Weight	Max. Load Capacity	Price
GT2530LVL (GIGT2530LVL)	Rapid	3	62.6"	54.3"	14.2"	25.6"	3.5 lbs	26.5 lbs.	664.95
GT2540LVL (GIGT2540LVL)	Rapid	4	67.7"	59.4"	12.6"	24"	3.7 lbs	26.5 lbs.	743.95

VISTA CRANE

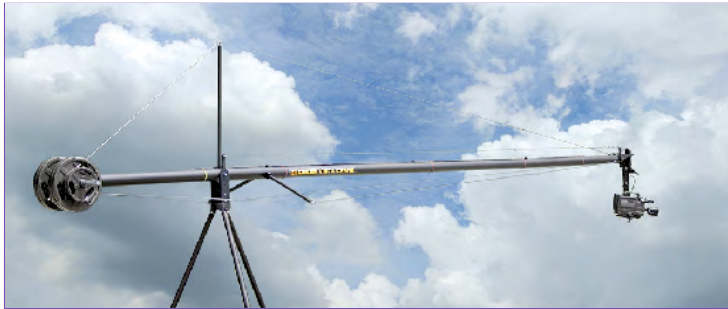

26' Crane with Full Range Camera Pan/Tilt Head

Glidecam's Vista Crane system offers quick assembly and precise 360° maneuverability. Designed for cameras up to 40 lbs., the crane is extremely versatile with varying boom lengths and balance settings. Adjustable boom arms allow

you to raise the height of your camera to over 30', yet all parts of the system can be stored easily in a lightweight carrying case and two custom padded canvas bags. Once the Vista Head III camera head is installed, a remote joystick lets you pan and tilt the camera with seamless continuity while the crane moves in perfect alignment upon operator command. The Vista Head III has a 3/8" mounting holes/slots allowing you to attach and horizontally balance a pan and tilt video head and can be set up in either high or low mode.



Vista Camera Crane with Vista Crane support base, Vista Crane and Vista Head III (Mfr# VC • B&H# GLVC).....**16,499.95**



Vista Head and Vista Head II

Vista Head and Vista Head II are the most affordable and versatile full range camera pan-tilt heads on the market today. They feature full 360° pan and tilt action. They can be set up and operated in both high mode (overslung) and low mode (underslung). The Vista Head is designed to handle cameras weighing up to 20 pounds with ease, while the Vista Head II supports cameras weighing up to 30 lbs. They feature super smooth, high-torque motors with 12v power. Their supplied control boxes provide smooth and accurate, proportional joystick control and come with a 15' extension cable. They also include a 12v AC transformer and power converter that can be used all over the world. The Vista Head works great with the Camcrane 200, as well as other brand crane and jib arms.

Vista Pan/Tilt Head (Mfr # VISTAHEAD • B&H # GLVH)**1899.95** **Vista II Pan/Tilt Head** (Mfr # VHD2 • B&H # GLVHD2).....**2399.95**

CAMCRANE 200

A tripod-mounted, boom-arm, camera crane system designed to allow you to smoothly boom your camera up or down, and move your camera in an infinite number of 360° arcs. When balanced and used correctly the Camcrane 200 moves with such tremendous precision and fluidity, that the results can only be called "picture perfect".

Camera cranes have been an industry standard for over 85 years. People have used cranes to move cameras to new heights both literally and figuratively, and now you can too. Supporting up to 25 lbs., the Camcrane 200 is the most affordable and versatile crane of its type on the market today. With its ease of set-up and variable boom lengths, you'll soon find yourself shooting the shots that you've always dreamed of.

Camcrane 200 Mfr # CC200 • B&H # GLCC200)**439.95**



HI-POD

CORE X4

Extreme Monopod

The best way to get high altitude shots. While others are straining to hold their cameras over their heads, unable to monitor what they are shooting and hoping for useable footage, the Core X4 extends to an amazing 30' allowing you to relax and concentrate on getting the best shot with ease. And its small footprint means shooting in a crowd won't block anyone's view.

The Core X4 lets you get the shots you're looking for with maximum comfort and minimum hassle. It is designed with the professional videographer in mind, allowing fast and easy setup and can be ready to use on site within minutes.

FEATURES

- ◆ The Core X4's unique head mount system allows you to use a variety of different cameras of various sizes. It will accommodate any camcorder - with remote LANC control - up to 15 lbs.
- ◆ Each turn of the tilt wheel control tilts the camera-mount smoothly up and down - up to a full 90°. You can shoot at any tilt angle needed to get the shot, from nearly straight up, to looking straight down on your subject.
- ◆ Users can monitor the shot comfortably at eye-level, even as they pan, tilt and zoom the camera as needed up to 30' in the air. It allows one cameraperson to get shots that previously would only have been possible with large and cumbersome crane setups that require an entire crew of operators.
- ◆ Control pan and zoom with ease using the handle-mounted LANC controller that attaches via internal cabling - cables are built into the mast itself - to your camera's remote LANC control, allowing you to control your camera comfortably and easily at any height.
- ◆ Controlling the tilt of your camera is easy with the unique tilt-wheel control. The advanced pulley system gives you full crane control, without the bulk. A short jog forward or backward with the wheel mechanism tilts the camera up or down as needed. As the mast is extended or lowered to the desired height, the wheel unit spools out or takes up the needed amount of cable, and then locks into place for use.
- ◆ The wheel and handle assembly is fully adjustable. It can be raised or lowered on the mast to whatever position the user prefers. Constructed of virtually indestructible lightweight aluminum and designed to weather the elements, it will last a full lifetime of use.
- ◆ The built-in LCD (NTSC/PAL) monitor allows you to easily see what you're shooting even with the camera elevated to a full 30' in the air. The monitor is also adjustable. It can tilt forward or backward to eliminate glare and provide the best viewing angle. And can be raised or lowered to accommodate any height and angle the operator is comfortable with.
- ◆ The LCD monitor is powered by the included battery pack, which is worn around the waist. Provides up to 9-hours of hassle-free use, and plugs into the HI-POD unit via cable with 4-pin XLR connector.
- ◆ Made of hard rubber that's built to last, the pivoting foot allows the operator to smoothly turn the Core X4, thus making for fluid pans.
- ◆ A small setup stand is included, making it easy to load your camera onto the head mount, raise the mast to the desired height, and go.

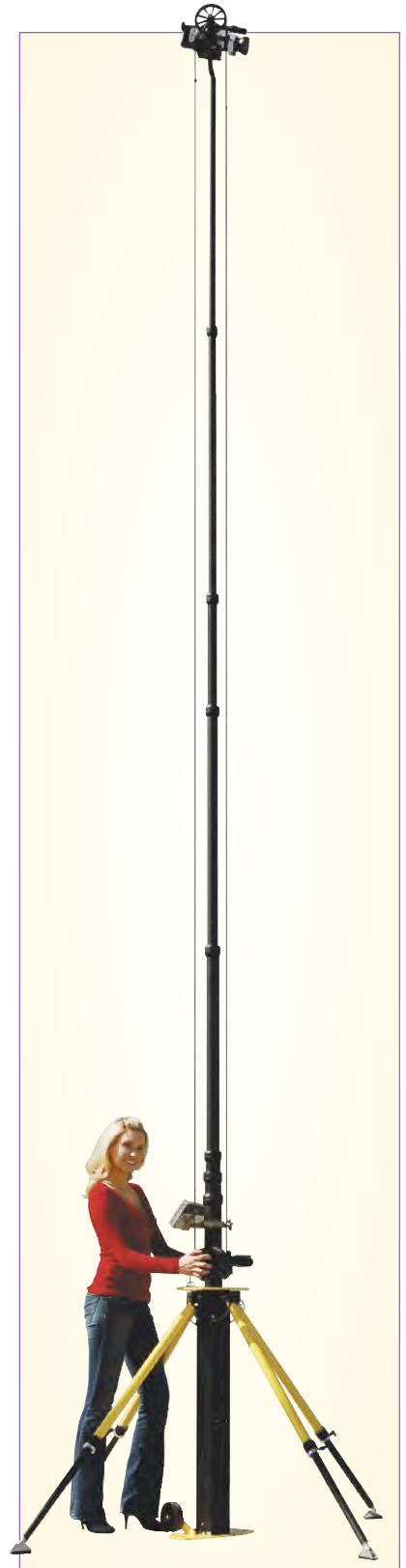

Core X4 Extreme Monopod (B&H # HIHP)5149.50

JONYJIB

JONYJIB 2



Available in four sizes, the JonyJib 2 can be fitted with optional accessories like the MotorHead 20 or 30 motorized pan & tilt unit, a motorized focus and zoom unit for broadcast lenses, a ZR1000 LANC zoom & focus unit and an LCD monitor all neatly connected via an optional wiring kit, power distribution box and an Anton Bauer Gold mounting plate.

What sets the JonyJib 2 apart from other cranes, is its ability to telescope and nest within itself. Its modularity is built on its lightweight, octagonal, aluminum, black powder-coated 4' extension sections which start at the tail of the jib with the largest diameter, and progressively get smaller as you get closer to the camera. The best part is, the arm breaks down to fit into an optional 48" tripod bag or case. The pivot, camera platform, rear control center and miscellaneous items fit into an optional Pelican 1650 carrying case.

The JonyJib 2 is expandable from 9' (2 sections) to 18' (5 sections) in 3' increments. Each extension tube is 4' long giving a 1' overlap between sections. Since each section slides out, pulled from the previous sections, you may store unused sections in the tail as ballast weight. This lightens your counterweight demand. You can buy as few, or as many sections as you need, then purchase more sections when you need them.

The pivot point is pre-drilled to mount the Anton Bauer Gold Mount plate kit that feeds a 12v power distribution box at the tail.

The distribution box feeds 12 volt power to the motorized pan & tilt head, the monitor and the camera. The pivot point is also pre-drilled to mount an optional monitor platform for 8-9" CRT style monitors. The adjustable camera platform leveling tether is also anchored at the pivot point. The camera platform is designed to over-sling or under-sling the motorized pan & tilt head without any changes. Just attach it 'either way' and there's 360° pan & tilt clearance. The main arm and extension sections are aluminum while the pivot point, camera platform and rear control center are steel. JonyJib 2's are powder-coated with a cobalt black finish, have a rear control center and 100mm mounting hub.

JonyJib 2 - 9 (Mfr # JONYJIB2 09 • B&H # JOJJ9)
9' jib with rear control center- supports 35 lbs.....**1349.95**

JonyJib 2 - 12 (Mfr # JONYJIB2 12 • B&H # JOJJ12)
12' jib with LCD monitor mount- supports 30 lbs.....**1694.95**

Transport Bag for JonyJib 2-9 (Mfr # JJBAG9 • B&H # JOBJ9).....**259.95**
Transport Bag for JonyJib 2-12 (Mfr # JJBAG12 • B&H # JOBJ12)**259.95**

JonyJib 2 - 15 (Mfr # JONYJIB2 15 • B&H # JOJJ15)
15' jib with rear control center- supports 35 lbs.....**2164.95**

JonyJib 2 - 18 (Mfr # JONYJIB2 18 • B&H # JOJJ18)
18' jib with LCD monitor mount- supports 20 lbs.....**2499.95**

Transport Bag for JonyJib 2-15 (Mfr # JJBAG15 • B&H # JOBJ15).....**259.95**
Transport Bag for Jony Jib 2-18 (Mfr # JJBAG18 • B&H # JOBJ18).....**259.95**

JONYJIB PRO

Like the JonyJib2, the PRO version has the ability to telescope and nest within itself. This crane's modularity is built on its lightweight, octagonal, aluminum, black anodized 4' extension sections which start at the tail of the jib, with the largest diameter, and progressively get smaller as you get closer to the camera. The best part is, the arm breaks down to fit into a 48" tripod bag or case. The pivot, camera platform, rear control center and miscellaneous items fit into a Pelican 1650 case.

The JonyJibPRO is expandable from 9' (2 sections) to 30' (9 sections) in 3' increments. Each extension tube is 4' long giving a 1' overlap between sections. Since each section slides out, pulled from the previous sections, you may store unused sections in the tail as ballast weight. This lightens your counterweight demand. Buy as few, or as many, sections as you need, then purchase more sections when you need them.

The pivot point is pre-drilled to mount an optional Anton Bauer Gold Mount plate kit that feeds a 12v power distribution box at the tail. The distribution box feeds power to the motorized pan & tilt head, zoom & focus controls, the monitor and the camera. The pivot point is also pre-drilled to mount an optional monitor platform for 8-9" CRT style monitors. The adjustable camera platform leveling tether is also anchored at the pivot point. The camera platform is designed to over-sling or under-sling the motorized pan & tilt head without any changes. Just attach it 'either way' and there's 360° pan & tilt clearance. The main arm and extension sections are aluminum while the pivot point, camera platform and rear control center are steel. They're all powder coated with a cobalt black finish.



JonyJib Pro - 9
JonyJib Pro - 12

JonyJib Pro - 15
JonyJib Pro - 18

JonyJib Pro - 21
JonyJib Pro - 24

JonyJib Pro - 27
JonyJib Pro - 30

TH-M20



Aluminum 2-Stage Tripod with Fluid Head

Designed to be used with lightweight Mini DV and HDV camcorders weighing up to 8.8 lbs., the unique TH-M20 features a true fluid head with integrated 65mm claw ball, making leveling smooth and steady even on the bumps or the slopes. Elliptical double leg sections made of aluminum alloy construction makes for a rugged support which is as light as it is durable. The mid-range spreader adds structural integrity while accommodating angled and/or irregular terrain. Includes oversized rubber feet for greater stability, and comes complete with carrying case and shoulder strap for a comfortable over-the-shoulder solution on the go.

TH-M20 Aluminum 2-Stage Tripod with Fluid Head (Mfr # THM20; B&H # LITHM20): With 65mm ball base fluid head, quick release plate, mid-level spreader, and soft case. Supports 8.8 lbs**179.95**

DL-2 Dolly (Mfr # DL2; B&H # LIDL2): Each wheel has a foot activated lock/release pedal making it easy to lock-down and release without having to bend over.....**99.95**

LS-22 SYSTEMS

LS-22 systems are based on the H22 fluid head. The H22 is fitted with an adjustable two positions of counterbalance for front or back heavy cameras, as well as standard cameras weighing up to 8.8 lbs. Very affordable, the H22 also features light fixed fluid drag and a 75mm claw ball for fast, efficient leveling. Ideal for DV and HDV camcorders, a newly developed, magnesium-made quick shoe with butterfly camera screw facilitates fine adjustment of counterbalance. Disc caliper tilt brake ensures operator safety and camera security. Dual rosettes allow left-handed or two-handed operation.

T58 Aluminum 1-Stage Tripod: Full featured tripod with an industry standard 75mm bowl, the T58 features aluminum alloy construction, robust single extension design and positive locking leg knob for fast, confident setups. Supports up to 22 lbs.

T68 Aluminum Two-Stage Tripod: Supporting loads up to 98 lbs., the T68 accepts most 75mm ENG-oriented fluid heads, while rotary stage locks assure dependable, tool-free setup. Tandem aluminum alloy upper leg sections provide superior torsion resistance. Each leg terminates with a hardened steel spike for use on soft, unstable ground.



	LS-22	LS-22M	LS-22 (2A)	LS-22M (2A)
Load Capacity	8.8 lbs.	8.8 lbs.	8.8 lbs.	8.8 lbs.
Tilt Angle	+90/-60	+90/-60	+90/-60	+90/-60
Drag Mode	Fix	Fix	Fix	Fix
Weight	8 lbs.	8 lbs.	8 lbs.	8 lbs.
Max. Height	61"	58"	58"	58"
Min. Height	30"	25.5"	25.5"	25.5"
Ball Diam.	75mm	75mm	75mm	75mm

LS-22 SYSTEMS

LS-22 (Mfr # LS22ZC3; B&H # LILS22J): Includes H22 fluid head, PH-2 pan arm, T58 tripod, SP-1 spreader and TC-60 case.....**399.95**

LS-22M (Mfr # LS22M; B&H # LILS22M): Includes H22 fluid head, PH-2 pan arm, T58 tripod, MS-1 spreader and TC-50 case.....**479.95**

LS-22 (2A) (Mfr # LS222A; B&H # LILS222A): Includes H22 fluid head, PH-2 pan arm, T68 tripod, SP-1 spreader and TC-60 case.....**469.95**

LS-22M (2A) (Mfr # LS22M2A; B&H # LILS22M2A): Includes H22 fluid head, PH-2 pan arm, T68 tripod, MS-1 spreader and TC-50 case**499.95**

LS-38 & LS-55 SYSTEMS



LH-55
Head

LS-38 systems are based on of H38 fluid head and T72 two-stage aluminum tripod. LS-55 systems are the same except they step-up with the LS-55 fluid head.

H38 Fluid Head: A 75mm fluid head with fixed counterbalance and silky-smooth fixed fluid drag, the H38 supports 8-18 lbs. with a 75mm claw ball for fast and secure leveling. Sliding plate with 3/8 screw with video pin balances uneven camera/lens configurations. Dual rosettes allow left-handed or two-handed operation.

H55 Fluid Head: The H50 Fluid Head has 2-step drag control for both Pan and Tilt, and a sliding quick mount plate with 3" (80mm) travel for camera balance. Tilt angle is $\pm 90^\circ$. Includes 75mm claw-ball, one pan handle (PH-7) and claw-ball locking knob. Camera load capacity is 8-22 lbs. Weighs 13.5 lbs. Dual rosettes allow left-handed or two-handed operation.

T72 Aluminum Two-Stage Tripod: Supporting loads up to 98 lbs., the T72 accepts most 75mm ENG-oriented fluid heads, while rotary stage locks assure dependable, tool-free setup. Tandem aluminum alloy upper leg sections provide superior torsion resistance. Each leg terminates with a hardened steel spike for use on soft, unstable ground. At the end of the day, a convenient retractable lanyard hooks all three legs together for transport.

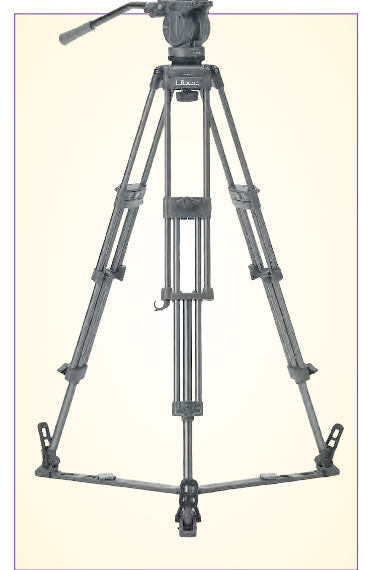

	LS-38 (2A)	LS-38M (2A)	LS-55 (2A)	LS-55M (2A)
Load Capacity	8-18 lbs.	8-18 lbs.	8-22 lbs.	8-22 lbs.
Tilt Angle	+90/-80	+90/-80	+90/-90	+90/-90
Drag Mode	Fix	Fix	Fix	Fix
Weight	13 lbs.	11 lbs.	13.5 lbs.	13.5 lbs.
Max. Height	63"	63"	63"	63"
Min. Height	22"	22"	22"	22"
Ball Diam.	75mm	75mm	75mm	75mm

LS-38 & LS-55 SYSTEMS

LS-38 (2A) (Mfr # LS382A • B&H # LILS382A): Includes H38 fluid head, PH-3 pan arm, T72 tripod, SP-1 spreader and TC-60 case.....**649.95**

LS-38M (2A) (Mfr # LS38M2A • B&H # LILS38M2A): Includes H38 fluid head, PH-3 pan arm, T72 tripod, MS-2 spreader and TC-60 case**675.95**

LS-55 (2A) (Mfr # LS552A • B&H # LILS552A): Includes H55 fluid head, T72 two-stage tripod, SP-1 ground spreader and TC-60 soft case**899.95**

LS-55M(2A) (Mfr # LS55M2A • B&H # LILS55M2A): Includes H55 fluid head, T72 two-stage tripod, MS-2 mid-level spreader, FP-3 large rubber feet and TC-60 soft case.....**953.95**

PH-9 Zoom Handle

Now you can have off camera control of both record and zoom functions (with two-phase zoom speed control) in a single ergonomically designed pan handle. The adjustable PH-9 adapts to most Canon and Fujinon ENG type 8-pin connector lenses and will conform to many Fujinon broadcast lenses with the addition of a 12-pin conversion adapter.



- ◆ Two record switches are available (top and bottom side of pan handle) for use, depending on pan handle position. Record/Return function can be alternated with Rec/Ret exchange switch.
- ◆ Easy manipulation of zoom and record On/Off function enables smoother and smarter shooting.
- ◆ Two speed zoom (fast or slow). Length or angle of pan handle is easily adjustable.

- ◆ Equipped with 8-pin connector as standard for controlling both Canon and Fujinon lenses (just set the Canon/Fujinon lens exchange switch). A 12-pin connector for controlling certain Fujinon broadcast lenses is available as an option.

PH-9 Zoom Controller Handle

(Mfr # PH9 • B&H# LIPH9)**319.95**

LS-60 SYSTEMS

LS-60 systems are based on the H60 fluid head and T78 single-stage or T98 two-stage aluminum and carbon fiber tripods. The H60 weighs 9 lbs. and has a load capacity of 17-28 lbs.



LH-60 Head

H60 Fluid Head: Supporting up to 28 lbs., the H60 features 2-mode

(strong and weak) torque change for pan and tilt, sliding plate (50mm forward and backward) to accommodate uneven payloads, and a 2-step fluid drag that makes setup rapid and repeatable. 100mm diameter claw ball makes leveling smooth and steady even on the bumps or the slopes. For easy setup, the H60 includes a bubble level. Comes equipped with a PH-7 extendable pan handle and sliding camera plate.

	LS-60	LS-60M	LS-60 (2A)	LS-60M (2A)	LS-60 (2C)	LS-60M (2C)
Load Capacity	17-28 lbs.	17-28 lbs.	17-28 lbs.	17-28 lbs.	17-28 lbs.	17-28 lbs.
Tilt Angle	+85/-65	+85/-65	+85/-65	+85/-65	+85/-65	+85/-65
Drag Mode	2-Step	2-Step	2-Step	2-Step	2-Step	2-Step
Weight	15.5 lbs.	15.5 lbs.	16.0 lbs.	16.0 lbs.	15.0 lbs.	15.0 lbs.
Max. Height	61"	62"	62"	63"	62"	63"
Min. Height	32"	38"	22"	30"	22"	30"
Ball Diam.	100mm	100mm	100mm	100mm	100mm	100mm

T78 Single-Stage Aluminum Tripod (Mfr # T78; B&H # LIT78)

Supporting loads up to 98 lbs., the T78 accepts most 100mm cine and video oriented fluid heads, while cine-style rotary stage clamps assure dependable leg locking regardless of ambient temperatures. Tandem aluminum alloy upper leg sections provide superior torsion resistance. Each leg terminates with a hardened steel spike for use on soft, unstable ground. At the end of the day, a convenient retractable lanyard hooks all three legs together for transport**319.95**

T98 Two-Stage Aluminum Tripod (Mfr # T98; B&H # LIT98)

The T98 is a two-stage aluminum alloy tripod features robust die-cast 100mm receiver for rapid leveling and supports up to 100 lbs. Dual-tubed upper leg sections provide superior torsion resistance when executing hard pans, and the dependable rotary stage clamps are completely temperature-independent. Each leg terminates with hardened stainless steel spikes for use on soft, unstable ground. A convenient retractable lanyard fastens all three legs together for transport**534.95**

T98C Two-Stage Carbon Fiber Tripod (Mfr # T98C; B&H # LIT98C)

Made of carbon fiber composite construction, the T98C is as strong as its aluminum equivalent, yet 7 lbs. lighter. Supporting up to 98 lbs., rotary stage locks assure dependable, tool-free setups, and the 100mm half-bowl accepts most ENG-oriented fluid heads. Each leg terminates with a hardened stainless steel spike for use on soft, unstable ground. Convenient retractable lanyard hooks all three legs together for transport**749.95**

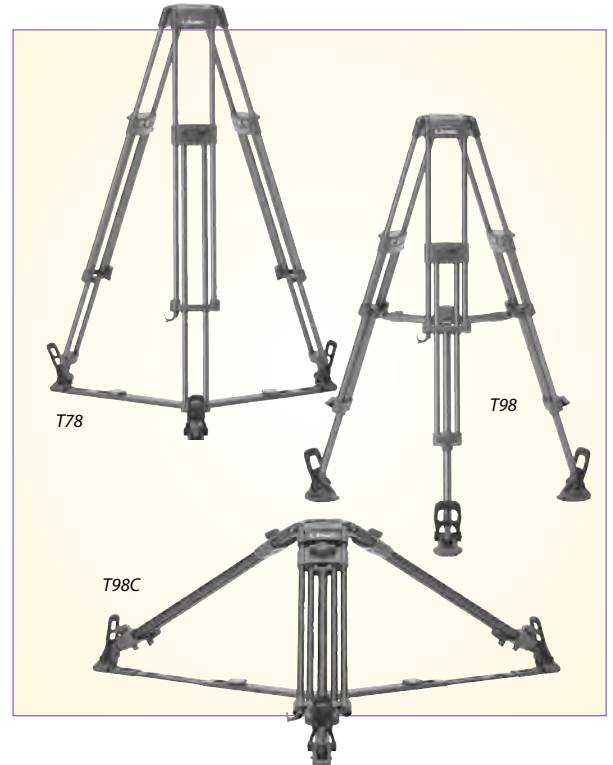

LS-60 SYSTEMS

H60 Fluid Head: With PH-7 Pan Arm and camera plate (Mfr # H60 • B&H # LIH60)**1069.95**

LS-60 (Mfr # LS60 • B&H # LLS60M): Includes H60 fluid head, PH-7 pan arm, T78 tripod, SP-1 ground-level spreader, and SC-7 soft case**1499.95**

LS-60M (Mfr # LS60M • B&H # LLS60M): Includes H60 fluid head, PH-7 pan arm, T78 tripod, BR-3S mid-level spreader, FP-3 large rubber feet, and SC-7 soft case**1608.95**

LS-60 (2A) (Mfr # LS602A • B&H # LLS602A): Includes H60 fluid head, PH-7 pan arm, T98 tripod, SP-1 ground-level spreader and SC-9 soft case**1699.95**

LS-60M (2A) (Mfr # LS60M2A • B&H # LLS60M2A): Includes H60 fluid head, PH-7 pan arm, T98 tripod, BR-3S mid-level spreader, FP-3 large rubber feet and SC-9 case**1823.95**

LS-60 (2C) (Mfr # LS602C; B&H # LLS602C): Includes H60 fluid head, PH-7 pan arm, T98C two-stage carbon fiber tripod, SP-1 ground-level spreader, and SC-9 soft case**1896.95**

LS-60M (2C) (Mfr # LS60M2C; B&H # LLS60M2C): Includes H60 fluid head, PH-7 pan arm, T98C two-stage carbon fiber tripod, BR-3S mid-level spreader, FP-3 large rubber feet and SC-9 soft case**1978.50**

LS-70 • LS-85 SYSTEMS



The heart of the LS-70 systems is the H-70 fluid head. Supporting up to 33 lbs., the H70's counterbalance mechanism supports various operating configurations including camcorder, standalone camera, even studio configuration with a large viewfinder. Systems include the T78 single-stage, or T98 two-stage aluminum and carbon fiber tripods (see previous page for description).

To accommodate varying payloads (13-33 lbs.), a 4-step counterbalance system and sliding camera plate provide finger-tip handling up to the load limit. The sliding plate features a patented locking mechanism and allows 4" (100mm) of travel for camera balance. The tilt and pan functions employ a simple 4 steps change system to select a torque. The patented 4-Step Drag Control System permits four individual levels of drag tension to be set on either pan or tilt to accomplish the smoothest camera moves imaginable. Makes setup fast and repeatable with a quick twist of an ergonomically-positioned knob.

LS-70 SYSTEMS

- H70 Fluid Head:** With PH-7 Pan Arm, bubble level and camera plate (Mfr # H70 • B&H # LIH70)**1819.95**
- LS-70** (Mfr # LS70; B&H # LILS70): Includes H70 fluid head, PH-7 pan arm, T78 tripod, SP-1 ground-level spreader, and SC-9 soft case.....**2059.95**
- LS-70M** (Mfr # LS70M • B&H # LILS70M): Includes H70 fluid head, PH-7 pan arm, T78 tripod, BR-3S mid-level spreader, FP-3 large rubber feet, and SC-9 soft case.....**2299.95**
- LS-70 (2A)** (Mfr # LS702A • B&H # LILS702A): Includes H70 fluid head, PH-7 pan arm, T98 tripod, SP-1 ground-level spreader, and SC-9 soft case ..**2388.95**

- LS-70M (2A)** (Mfr # LS70M2A • B&H # LILS70M2A): Includes H70 fluid head, PH-7 pan arm, T98 tripod, BR-3S mid-level spreader, FP-3 large rubber feet and SC-9 case.....**2469.95**
- LS-70 (2C)** (Mfr # LS702C • B&H # LILS702C): Includes H70 fluid head, PH-7 pan arm, T98C carbon fiber tripod, SP-1 ground-level spreader, and SC-9 soft case.....**2583.95**
- LS-70M (2C)** (Mfr # LS70M2C; B&H # LILS70M2C): Includes H70 fluid head, PH-7 pan arm, T98C carbon fiber tripod, BR-3S mid-level spreader, FP-3 large rubber feet and SC-9 soft case.....**2699.95**

H85 FLUID HEAD

Supporting up to 38 lbs., the H85 features a patented counterbalance system that allows the optimum balance to be easily achieved for diverse camera weights and angles. Provides a tilt angle of +90/-90, enabling stable shooting in all situation. Unique pan and tilt serial drag system allows for smooth camera operation in all situations. Whip pans? Slow motion sequences? No problem- continuously-variable true fluid drag provides precisely the right amount of dampening required with a quick twist of an ergonomically-positioned knob. The LED illumination leveling device insures fast, accurate positioning in low light situation (extended battery life for 2 years). Adoption of LED allows the leveler to light internally for easily leveling in dark area. Lighting time is about 15 seconds. Snap in dove tail plate sliding plate system achieves an almost immediate camera balance through a ±50mm positioning range. Reliable operation through a temperature range of -22F to 140 ensures steady operation under the most severe climatic conditions.



- H80 Fluid Head:** With PH-7 Pan Arm and camera plate (Mfr # H70; B&H # LIH70).....**1819.95**

LS-85 SYSTEMS

- LS-85** (Mfr # LS85 • B&H # LILS85): Includes H85 fluid head, PH-7 pan arm, T78 single-stage tripod, SP-1 ground-level spreader, and SC-9 soft case. Supports 28 lbs.....**3459.95**
- LS-85M** (Mfr # LS85M • B&H # LILS85M): Includes H85 fluid head, PH-7 pan arm, T78 single-stage tripod, BR-3S mid-level spreader, FP-3 large rubber feet, and SC-9 soft case.....**3558.95**
- LS-85 (2A)** (Mfr # LS852A • B&H # LILS852A): Includes H85 fluid head, PH-7 pan arm, T98 two-stage tripod, SP-1 ground-level spreader and SC-9 soft case.....**3626.95**

- LS-85M (2A)** (Mfr # LS85M2A • B&H # LILS85M2A): Includes H85 fluid head, PH-7 pan arm, T98 two-stage tripod, BR-3S mid-level spreader, FP-3 large rubber feet and SC-9 case.....**3753.95**
- LS-85 (2C)** (Mfr # LS852C • B&H # LILS852C): Includes H85 fluid head, PH-7 pan arm, T98C two-stage carbon fiber tripod, SP-1 ground-level spreader, and SC-9 soft case.....**3849.95**
- LS-85M (2C)** (Mfr # LS85M2C • B&H # LILS85M2C): Includes H85 fluid head, PH-7 pan arm, T98C two-stage carbon fiber tripod, BR-3S mid-level spreader, FP-3 large rubber feet and SC-9 soft case.....**3948.95**

LS-100 SYSTEMS

H 100 Fluid Head

Extremely durable, the H100 handles up to 50 lbs. with newly designed retractable winding up counter balance knob which enable users to adjust the balance at minimum strength. Like the H85, the H100 features a patented counterbalance system that allows the optimum balance to be easily achieved for diverse camera weights and angles. Pan and tilt serial drag system with LED illumination leveling device. Large snap in dove tail quick release plate slides 50mm forward and backward. Reliable operation through a temperature range of -22F to 140 ensures steady operation under the most severe climactic conditions.

H100 Fluid Head: With PH-7 Pan Arm and camera plate (Mfr # H100 • B&H # LIH100)**3999.95**

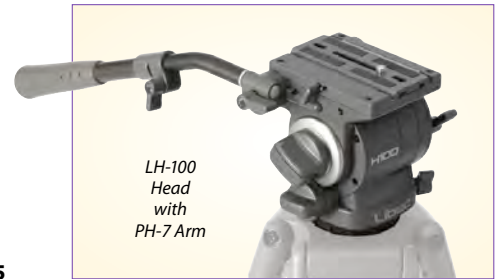

T-102 Single-Stage

Heavy-Duty Aluminum Tripod (Mfr # T102 • B&H # LIT101)

Ideal for location and studio applications, the T-102 is a heavy-duty aluminum single-stage tripod that offers high-payload capacity and durable design. Equipped with a high impact resistant 100mm-bowl base, the T-102 operates with a mid-level or on-ground spreader and provides a payload capacity of 198 lbs.....**1029.95**

T-103 Two-Stage

Heavy-Duty Aluminum Tripod (Mfr # T103 • B&H # LIT103)

The T-103 is a two-stage extra heavy-duty aluminum alloy tripod which supports up to 198 lbs. Dual-tubed leg sections provide superior torsion resistance when executing hard pans, and the dependable cine-style rotary stage clamps are completely temperature-independent. Each leg terminates with hardened stainless steel spikes for use on soft, unstable terrain or with a ground-level a spreader on delicate surfaces. Convenient retractable lanyard fastens all three legs together for easy transport**1174.95**

LS-100 SYSTEMS

LS-100 (Mfr # LS100 • B&H # LILS100): Includes H100 fluid head, PH-7 pan arm, T102 single-stage tripod, SP-5 ground-level spreader, and SC-7 soft case. Supports 28 lbs.....**4995.95**

LS-100M (Mfr # LS100M • B&H # LILS100M): Includes H100 fluid head, PH-7 pan arm, T102 single-stage tripod, BR-5S mid-level spreader, FP-3 large rubber feet, and SC-7 soft case.....**5179.95**

LS-100 (2A) (Mfr # LS1002A • B&H # LILS1002A): Includes H100 fluid head, PH-7 pan arm, T103 two-stage tripod, SP-5 ground-level spreader and SC-7 soft case**5279.95**

LS-100M (2A) (Mfr # LS100M2A • B&H # LILS100M2A): Includes H100 fluid head, PH-7 pan arm, T103 two-stage tripod, BR-5S mid-level spreader, FP-3 large rubber feet and SC-7 case**5443.95**

	LS-70 Systems						LS-85 Systems						LS-100 Systems			
	LS-70	LS-70M	LS-70 (2A)	LS-70M (2A)	LS-70 (2C)	LS-70M (2C)	LS-85	LS-85M	LS-85 (2A)	LS-85M (2A)	LS-85 (2C)	LS-85M (2C)	LS-100	LS-100M	LS-100 (2A)	LS-100M (2A)
Load Capacity	13-33 lbs.	13-33 lbs.	13-33 lbs.	13-33 lbs.	13-33 lbs.	13-33 lbs.	11-38 lbs.	11-38 lbs.	11-38 lbs.	11-38 lbs.	11-38 lbs.	11-38 lbs.	11-50 lbs.	11-50 lbs.	11-50 lbs.	11-50 lbs.
Tilt Angle	+90/-75	+90/-75	+90/-75	+90/-75	+90/-75	+90/-75	+90/-90	+90/-90	+90/-90	+90/-90	+90/-90	+90/-90	+90/-90	+90/-90	+90/-90	+90/-90
Drag Mode	4-Step	4-Step	4-Step	4-Step	4-Step	4-Step	Continu.	Continu.	Continu.	Continu.	Continu.	Continu.	Continu.	Continu.	Continu.	Continu.
Weight	17 lbs.	17 lbs.	17.5 lbs.	17.5 lbs.	16.5 lbs.	16.5 lbs.	17 lbs.	17 lbs.	17.5 lbs.	17.5 lbs.	16.5 lbs.	16.5 lbs.	24 lbs.	23 lbs.	23 lbs.	25 lbs.
Max. Height	63"	62"	63"	63"	63"	62"	62"	62"	63"	62"	63"	62"	62"	62"	62"	75"
Min. Height	32"	38"	22"	22"	22"	30"	32"	38"	22"	30"	22"	22"	43"	43"	43"	38"
Ball Diam.	100mm	100mm	100mm	100mm	100mm	100mm	100mm	100mm	100mm	100mm	100mm	100mm	100mm	100mm	100mm	100mm

Tripod Dollies

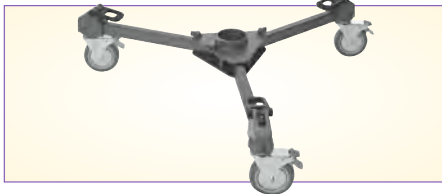

Designed to work with all tripods (except the TH-M20, T-102 and T-103), the DL-3 and DL-5S (variable length—makes it easy to move around close quarters) allow you to dolly in any direction without the need for tracks. Each 4" wheel has a foot activated lock/release pedal making it easy to lock-down and release without having to bend over. Constructed of corrosion-resistant aluminum alloy, they also feature a patented folding system which is operated with the turn of a lever.

DL-3 Dolly: Fixed spread (36"), folded length is 14", weighs 9 lbs (Mfr # DL3 • B&H # LIDL3).....**219.95**

DL-5S Dolly:

Variable spread (36-46"), folded length is 20", weighs 9 lbs (Mfr # DL5S • B&H # LIDL5S)**319.95**

DL-8 Dolly (Mfr # DL8 • B&H # LIDL8)

Equipped with 4" indoor wheels, the DL-8 is designed for use with the T-102/T-103 heavy-duty tripods. It features foot-controlled independent brakes, durable cast and extruded aluminum alloy construction, and sturdy neoprene tie-downs for rapid, secure assembly. Folded length is 24" weighs 9 lbs.....**775.95**

Ground Spreader



Lightweight for fast setup and tear down, Libec's ground spreaders are made of ABS plastic with molded rubber tie-downs. Each section of the spreader extends 5" and has a graduated scale for even adjustment. Tripods fold with the spreader attached.

SP-1: Ground spreader for T-72, T78, T98, T98C (Mfr # SP1 • B&H # LISPI).....**109.95**

SP-5: Ground spreader for the T101 (Mfr # SP5 • B&H # LISPS)**169.95**

P110

Pneumatic Pedestal

The P110 is a small size pedestal that offers great flexibility without taking up too much space. Featuring an advanced air pressure system, the P110 smoothly handles loads up to 66 lbs., easily accommodating mid-range camera packages which can include light-weight tele-prompter system, as well as professional cameras used in a small studio, at events, or any kind of industrial and institutional application.

- ◆ Two stage pneumatic design—the lower mechanical portion locks into place to provide secure camera positioning while the upper pneumatic column offers smooth camera elevation and depression moves.
- ◆ Air pump attached to the main body frame allows air to be pumped in anywhere and anytime – even while a camera is mounted on the pedestal. This allows you to check and adjust air pressure while using the pedestal.
- ◆ Air pressure can be gradually adjusted by discharging air through a bleed valve. A safety valve protects against over pressurizing of pneumatic column.
- ◆ Large steering wheel affords greater ease in handling when shifting columns up and down, or when moving the pedestal.
- ◆ Large double wheel 5" casters allow the P110S to move smoothly and quickly. The double stopper system secures the wheels and axle shafts by just snapping in.



- ◆ Multi positioning caster locking positions to guarantee exact, repeating, pedestal dolly moves. A track lock mechanism locks the wheels of the pedestal, so that it only moves in a desired position.
- ◆ Cable guards prevent the casters from rolling over and becoming tangled in camera cables when the tripod is moved around in a studio.
- ◆ The column and Dolly can be quickly disassembled for convenient transport. Column weighs 18 lbs., the Dolly 16 lbs.
- ◆ Maximum height is 61", minimum is 31". Weighs 40 lbs., supports up to 66 lbs. Attach the optional LA-100 Low Angle Adapter to shoot at low angles. (Height from the ground to mount is only 10")

STUDIO PEDESTAL SYSTEMS

110 Pneumatic Pedestal (100mm Bowl) with DL-10 Dolly

(Mfr # P110 • B&H # LIP110)**3999.95**

LA-110 Low Angle Adapter (Mfr # LA110 • B&H # LILAAP110)

For use with the DL-10 Dolly.....**263.95**

LS60PD Studio Pedestal System (Mfr # LS60PD • B&H # LILS60PD)

Includes P110 pedestal, H60 fluid head, and two PH-7 pan arms.....**4999.95**

LS70PD Studio Pedestal System (Mfr # LS70PD • B&H # LILS70PD)

Includes P110 pedestal, H70 fluid head, and two PH-7 pan arms.....**5449.95**

LS85PD Studio Pedestal System (Mfr # LS85PD • B&H # LILS85PD)

Includes P110 pedestal, H85 fluid head, and two PH-7 pan arms.....**6599.95**

LS100PD Studio Pedestal System (Mfr # LS100PD • B&H # LILS100PD)

Includes P110 pedestal, H100 fluid head, and two PH-7 pan arms.....**7795.95**

Mid-Level Spreaders

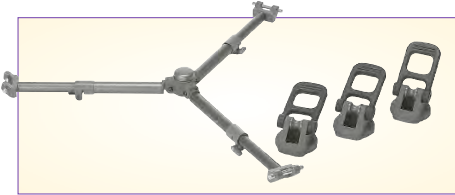

Mid-level spreaders are designed to stabilize the tripod legs in the most awkward positions. Two locking positions (45° and 180°) are provided to secure the leg spread. The spreaders can be detached from any one or all the legs for even greater flexibility. The MS-1 and MS-2 also include a set of three large feet to ensure stable shooting.

- MS-1 Mid-Level Spreader:** For T68 tripod. (Mfr # MS1 • B&H # LIMS1)**95.95**
- MS-2 Mid-Level Spreader:** For T78, T98, T98C tripods. (Mfr # MS2 • B&H # LIMS2)**214.95**
- MS-3 Mid-Level Spreader:** For the T102, T103 tripod—no feet (Mfr # MS3 • B&H # LIMS3)**257.95**

Zoom Controllers

Compatible with Canon and Fujinon lenses, Libec's unique zoom controls can clamp on tripod pan handles, monopods, stabilizers and other similar devices. Zoom speed is variable from slowest to fastest by a very sensitive thumb switch. The further you rotate the zoom controller, the faster the zoom speed.



- ZC-9Pro:** Universal zoom control for most ENG cameras (Canon and Fujinon lenses). (Mfr # ZC9PRO • B&H # LIZC9P)**229.95**
- ZC-9EX:** Zoom controller for the Sony PMW-EX1 with Canon or Fujinon lenses. (Mfr # ZC-9EX • B&H # LIZC9EX)**269.95**
- ZC-3DV:** Zoom controller for most Sony and Canon DV camcorders with LANC control, as well as Panasonic camcorders with cam remote jack. (Mfr # ZC3DV • B&H # LIZC3DV)**109.95**
- AS-5 Accessory Support:** Allows you to mount LCD monitors, lighting and other accessories on your video fluid head. My be attached to rosette of fluid head in upright or inverted position. Supports up to 2.2 lbs. (Mfr # AS5S • B&H # LIAS5S)**99.95**

JB-30U

Jib Arm with UM-3 Undermount Adapter

The JB-30U attaches quickly and easily to most conventional heads and tripods, giving it flexibility for use as a cost-effective studio crane where on-shot elevation is required, or on location where setup are critical. It provides precisely balanced booming with a load capacity of 44 lbs. from absolute ground level to 72" in height. The rear part of the arm, (which holds the counterweights), is easily adjustable to provide for the most suitable camera balance. An easily reversible bowl offers extremely low camera angles. Standard configuration includes a 75/100mm bowl base attachment. Standard barbell-type plates (not included) are employed for the counterweight, and the whole assembly sets up and breaks down in a simple, logical manner. (Mfr # JB30U • B&H # LIJB30)**2059.95**



- JB-30 Heavy-Duty Kit:** Includes the JB-30 jib arm, T101 tripod and DL-8 dolly. (Mfr # JBHEAVYKIT • B&H # LIJB30UHK)**2999.95**
- HM-1 Handle Mount for JB-30U Jib Arm** (Mfr # HM1 • B&H # LIHM1): Mounts on the back end of the jib arm, and allows use of additional pan arms, or an AS-5 remote monitor support. Good combination with PH-9 at rear end position zoom control.....**214.95**

Tracking Rail System

The Libec TR-320 tracking dolly system allows you to use your existing Libec tripod, pedestal or jib to achieve super smooth camera tracking movements at a very affordable price. The track comes in 32" sections and can be added to or reduced in length to suit the situation. Lightweight, compact and easily transportable CR-90 90° curves and EX-160S extra track lengths are available as options.



TR320 Track Rail System

The standard TR-320 package comes complete with 128" of straight track and a universal dolly that packs down into a neat carrying case for location work. This EX-160S is the ideal solution for when you need just a bit more track to roll on, or when you have a specific need for a short track layout. This extension is straight, 6' long and interfaces perfectly with the Libec track system. The CR-90 is a lightweight aluminum track set that sets up fast and easy. This set completes a 90° turn, and interfaces perfectly with the Libec track system.

- TR320 Track Rail System with Dolly and Transport Case - 10.5'** (Mfr # TR320 • B&H # LITR320)**1999.95**
- CR-90 Curved Track Rail with Case** (Mfr # CR90 • B&H # LICR90)**729.95**
- EX-160S Track Rail Extension with Case (Straight)** (Mfr # EX160S • B&H # LIEX160S).....**272.95**

VIDEO HEADS

526 Pro Fluid Video Head

Designed for heavy-duty, high-end ENG and EFP applications, the 526 is a feature-packed fluid video head that supports weight loads of up to 35 lbs. It features a replaceable and removable pan arm rosette, and large rubber-padded pan, tilt and drag knobs for a better grip. A precise fluid drag system comprised of three step settings for low, medium and high drag levels, plus an additional no-drag setting for such snap-pans and tilts. Counterbalance is achieved through an adjustable spring for camera weights between 17.6 and 33.1 lbs. The built-in 100mm half-ball adapts to a number of Manfrotto tripods with a 100mm receiver, allowing the quick levelling of the camera with the aid of the bright levelling bubble. The 526 comes with one pan arm and the long 3272 plate.



519 Pro Fluid Video Head

Professionals utilize a wide range of cameras including Mini DV, DV CAM, HD, and ENG. The versatile 519 is a compact, yet heavy duty fluid video head capable of accommodating a counterbalance payload from 3.3 up to 19.8 lbs. This is a revolutionary breakthrough, as the 519 is the only video head encompassing both interchangeable and adjustable counter-balance springs. Combining both features allow you to easily interchange a vast array of cameras as well as quickly fine-tune the perfect balance point of whatever camera being used, all with just one head. In addition, fluid drag is easily controlled with a large click-stop numbered knob in seven increments. Drag can be adjusted from the highest possible setting to nearly zero drag, allowing for the finest control through 360° pan and ±90° tilt.

516 Pro Fluid Video Head

Specifically designed for the latest DV camcorders used by documentary and industrial videographers, the 516 is very compact and light but can support cameras up to 22 lbs. This cost-effective high-performance head is equipped with fluid cartridges that provide continuous adjustable drag control. This system gives quite a wide range of friction control down to "zero drag" and operates on both pan and tilt axis. Additional features include separate tilt and pan locking mechanism; a fixed counter balance spring of 16.5 lb. load capacity at a center of gravity of 5"; two telescopic pan handles; and a bubble level. It can be mounted on a flat base tripod with a 3/8" female thread attachment or by attaching the ART 3141BALL to the head base, allowing it to fit a 100mm bowl.



	526	519	516	503HDV	501HDV	701RC2	700RC2
Load Capacity	35.3 lb.	22 lb.	22 lb.	17.6 lb.	13.2 lb.	8.8 lb.	4.4 lb.
Counter Balance	—	Interchangeable from 2.2 - 19.8 lbs.	Fixed 16.5	0 to 88 lbs.	Fixed 5.5	Fixed 16.5	—
Tilt Range	+75° -75°	+90° -90°	+90° -60°	+90° -60°	+90° -60°	+90° -60°	+90° -75°
Type of Drag	Continuous Variable	Continuous Variable	Continuous Variable	Continuous Variable	Fixed plus variable Teflon Friction	Fixed	Fixed
Head to Tripod Attach	100mm half bowl	75mm half bowl	3/8" female thread	3/8" female thread	3/8" female thread	3/8" female thread	3/8" female thread
Camcorder Weight	8.8 to 23.1 lb.	8.8 to 23.1 lb.	8.8 to 23.1 lb.	4.4 to 17.6 lb.	4.4 to 17.6 lb.	2.2 to 6.6 lb.	2.2 to 5.5 lb.
Mfr#/B&H #	526 / BO526	519 / BO519	516 / BO516	503HDV/BO503HDV	501HDV/BO501HDV	701RC2/BO701RC2	700RC2/BO700RC2
Price	1247.95	867.95	562.95	337.95	173.95	110.95	76.95

VIDEO HEADS

503HDV Pro Fluid Video Head

Designed for today's HDV professional shooters, the 503HDV has a completely new ergonomic, easy-to-use, functional design. It's features include large ergonomic locks and knobs allowing for a more solid grip and better control. For enhanced ease of use, the tilt lock and friction controls are located on the left side of the head. The 503HDV has an improved and adjustable counterbalance capacity: a switch controls the different counterbalance settings, allowing you to adjust the system to accommodate various payloads for different filming needs. The counterbalance system can be adjusted to four positions ensuring both smoother tilt movements and greater equipment safety. In addition, it has an illuminated levelling bubble and a replaceable pan bar rosette.



501HDV Pro Fluid Video Head

Inside the 501HDV is a fixed counterbalance spring (set for a typical weight of camera + accessories of 5.5 lbs.) that helps ensure both smoother tilt movements and greater equipment safety even when tilt locks are inadvertently left off. The easy-to-reach on/off switch allows the counterbalance system to be disengaged or re-engaged for different filming setups. The 501HDV video head also offers improved ergonomics with locks and knobs that allow a more solid grip and better fingertip control. Additional features include separate pan and tilt locks, gradual tilt friction adjustment system, flat base (with standard 3/8" thread), quick release camera plate and repositionable pan bar from its successful predecessor.

701RC2 Mini Video Head

The 701RC2 is one of the most compact and lightweight two-way heads found on the market and is designed to support the latest Mini DV and compact prosumer/professional compact High-Definition camcorders. Small and lightweight, the 701RC2 can accommodate a payload of up to 8.8 lbs. and is ideal for set-ups such as a fully equipped 3-CCD mini DV camcorder. It is equipped with a fixed 3.3 lb. counterbalance spring which combines with a camera plate attachment made of a touch and go/sliding plate who can shift from ± 15 mm from the 0 point to optimize the position of the counterbalance spring and deliver a wide range of balancing positions. Fluid drag on the 701RC2 is fixed. The 701RC2 has a fixed length pan bar with a soft handle and separate locking mechanisms to the head to adjust it as you like. The sliding quick-release video plate system is based on the 3157N equipped with the usual VHS pin.



700RC2 Mini Video Head

A compact and lightweight 2-movement video head designed principally to support the latest digital video equipment, the 700RC2 has a fixed length pan bar with soft handle and separate locking mechanisms for the 360° pan and the +90°/-75° tilt. Smooth and constant movements on both axes are assured by a fixed system of fluid cartridges. Equipped with quick release 3157N video plate system with VHS PIN and a secondary safety catch. Head to tripod attachment is 3/8" female.

TRIPODS

542ART ART Carbon Fiber Pro Video Tripod

Use of carbon fiber tubing makes this two-stage video tripod one of the lightest in its class. The 542 uses the patented A.R.T. (Advanced Release Technology) mechanism for the fastest opening, positioning and closing of any video tripod in the world—ideal for filming under pressure. Comes with a 100mm-75mm bowl adapter for compatibility with all industry-standard half-ball video heads. Included mid level “squid” spreader offers improved anti-torsion resistance and keeps legs locked safely in position even when space is cramped and tripod footprint is necessarily smaller. Double stainless steel spiked feet come with quick-on/off rubber shoes for better grip on smooth floors. No protruding parts, levers or knobs to catch or damage. When closed, tripod legs interlock without additional clips, straps or hooks to ensure compactness and prevent damage. Leg lock mechanism can be adjusted for increased or reduced tightness.

532ART ART Aluminum Pro Video Tripod

The aluminum version of the rapid deployment 542ART carbon tripod. The 532 also uses the patented A.R.T. (Advanced Release Technology) mechanism for the fastest opening, positioning and closing of any video tripod in the world. It comes with a 100mm-75mm bowl adapter, has a mid-level “squid” spreader, and double stainless steel spiked feet with quick-on/off rubber shoes for better grip on smooth floors. No protruding parts, levers or knobs to catch or damage. When closed, tripod legs interlock without additional clips, straps or hooks to ensure compactness and prevent damage. Leg lock mechanism can be adjusted for increased or reduced tightness.

525MVB/515MVB Lightweight Video Tripods

Two-stage, lightweight, high tensile aluminum tripods that are extremely rigid and stable, they have a die-cast aluminum crown with a built-in 75mm (525MVB) or 100mm interface bowl (515MVB), adjustable leg clamp levers for reliability and safety in the field and a floor-level spreader which aids tripod leg angle setting adjustment. Lowest leg section has twin spiked metal feet. The tripods can also be equipped with spiked feet shoes, different types of dollies and two models of mid level spreader.

3193/3186 Pro Video Tripods

Tandem aluminium legs combine with a 100mm half bowl attachment. Features include high tensile tubular aluminium legs with one step leg angle positioning system (21°). Legs can be adjusted within a 180° arc to other angle by using a 531SPRB or 530SPRB mid level spreader combined with a set of 565 spike foot shoes in case of unlevelled ground or by using a 3138 floor spreader. Legs can be locked to any height by a quick lever leg locks and stainless steel fittings. Twin spiked feet are standard. Otherwise identical, the 3186 is a short version of the 3193.

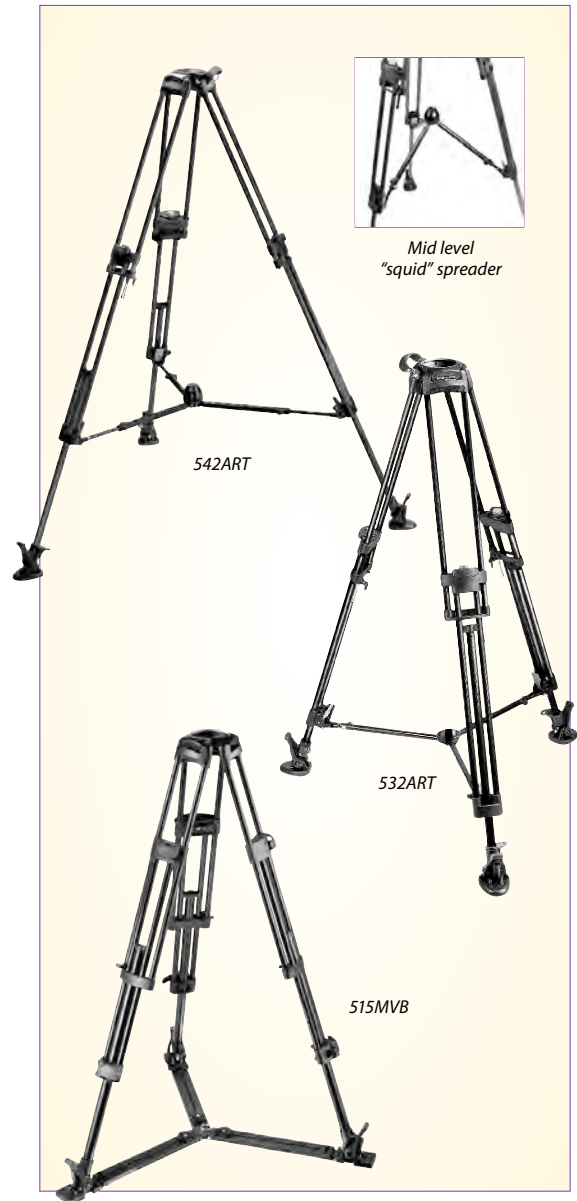

	542ART	532ART	525MVB	515MVB	3193	3186	3182	351MVB2	351MVCF	3068	528XB	3221WN
Closed Length	28.7"	28.7"	28.3"	28.3"	37.4"	20.5"	36.6"	27.7"	27.9"	37"	39"	25.6"
Min. Height	15.7"	15.7"	12.6"	12.6"	35.4"	19.3"	33.1"	24.8"	24.2"	18.1"	28.7"	3.1"
Max. Height	59.8"	59.8"	61.4"	61.4"	59.4"	26.8"	59.4"	59"	58"	57.9"	58.3"	54.3"
Weight	8.8 lb.	9.7 lb.	7.7 lb.	7.7 lb.	10.9 lb.	9.3 lb.	7.9 lb.	7.7 lb.	6.8 lb.	12.6 lb.	16.3 lb.	6.2 lb.
Load Capacity	33.1 lb.	33.1 lb.	33.1 lb.	33.1 lb.	44.1 lb.	44.1 lb.	44.1 lb.	28.6 lb.	28.6 lb.	39.7 lb.	110 lb.	15.4 lb.
Bowl	75/100mm	75/100mm	75mm	100mm	100mm	100mm	75mm	75mm	75mm		100mm	
B&H #	BO542ART	BO532ART	BO525MVB	BO515MVB	BO3190*	BO3185B	BO3181*	BO351MVB	BO351MVCF	BO3068	BO528XB	BO3221WN
Price	1453.95	1130.95	435.95	435.95		382.95		274.95	723.95	239.95	660.00	185.95

TRIPODS

3182 Lightweight Video Tripod

Supplied with a 75mm half bowl attachment, the 3182 is designed with tandem upper legs and single lower legs with variable angle adjustment and twin spiked feet. Tripod top spider has a two steps (18°-28°) leg angle positioning system. Legs can be adjusted within a 180° arc to other angle by using a 531SPRB or 530SPRB mid level spreader combined with a set of 565 spike foot shoes in case of unlevelled ground or by using a 3138 floor spreader. Leg locks by a quick lever and stainless steel fittings make this tripod extremely versatile and easy to use.

351MVB2 Lightweight Video Tripod

Equipped with a 75mm bowl combined with upper twin-leg design for greater rigidity, the 351MVB2 has a built-in shoulder spreader allowing you to adjust the legs at two different angles. To complete the package are twin-spiked feet to accommodate Manfrotto accessories such as their range of dollies. The result is an extremely portable, light and affordable professional video tripod.

351MVCF Carbon Fiber Lightweight Video Tripod

An innovative support solution for DV and Mini DV and compact ENG cameras, the 351MVCF offers unrivalled torsion rigidity with substantial weight savings. A two-stage carbon fiber video tripod with a 75mm half bowl, the 351MVCF combines together a twin leg design for the first stage and a single leg design for the second stage of the tripod, all completed with a double spiked feet. Legs have two angles adjustment while if they have to be adjusted at any angle of 180° the tripod needs to be equipped with a 3189 mid level spreader.

3068 Video Tripod

Stainless steel extension legs and extra sturdy leg locks make the 3068 the robust choice for video crews around the world. Remarkably stable, due to its rigid center brace construction and steel extension legs, which lower the center of gravity. Centerpost permits 9¼" of extension for precise positioning. Features built-in spirit level at the shoulder and telescopic mid level spreader. Unique variable-angle center brace system allows minimum elevation as low as 17¼". Extends to 67", weighs only 12½ lbs. Legs come complete with rubber feet and retractable metal spike for secure locking into a dolly or spreader.

528XB Video/Movie Video Tripod

With a massive 110 lb. load capacity, the 528XB is the ideal location tripod. It is a sturdy single-stage tripod with a single-tube leg structure. Tubes are made of stainless steel for strength under heavy loads, and aluminium for weight saving. The leg spread is fully adjustable, but also incorporates a 30° locked position for faster set up and greater strength. A 100mm bowl accepts industry-standard half-ball video heads and allows you to level the head quickly for accurate panoramic shots. The included claw ball allows you to use it with heads not equipped with a half ball. The 528XB includes a versatile mid-level spreader, which has telescopic "ratchet" braces that click into place in each of the preset positions for faster deployment. Each brace can be individually set, allowing each tripod leg to be separately positioned.

3221WN Video Tripod

Ideal for DV and Mini DV camcorders, the lightweight, sturdy and portable all-metal 3221WN is one of the Manfrotto's easiest and intuitive tripods to operate. It features four pre-set independent leg angles for great positioning flexibility and versatility, a long center column for extra adjustment, three leg warmers, quick flip lever locks and retractable rubber feet with steel spikes. The single-tube leg design helps keep weight and size to a minimum, yet offers ample anti-torsional rigidity and strength for compact video cameras.



MDeVe SERIES

The digital era has brought a drastic reduction in the weight and size of video camera equipment, matched by enormous advances in the picture quality achievable with the most minuscule of systems. Those working in the video sector are increasingly demanding camera supports tailored to these small cameras but that make no compromises in key areas such as rigidity which could jeopardize the fluidity and smoothness of camera movements.

Designed for DV, Mini DV and Micro DV markets, Manfrotto's MDeVe family of tripods provides high performance in an extremely compact and lightweight structure. The series is made up of six tripods; three are entirely in aluminum and three have carbon fiber leg sections with magnesium castings. All six are two-stage tripods and are supplied with quick-release leg locking levers, asymmetric leg angle presets and, patented, rapid center column with built-in levelling half ball. The fact that the 50mm diameter ball with bubble spirit level is attached not to the tripod top spider but to the top of the center column allows you to level the top plate (and consequently the head and camera) and even adjust the camera height without needing to make micro adjustments to the tripod legs, representing a massive time saving and giving you considerable added convenience.

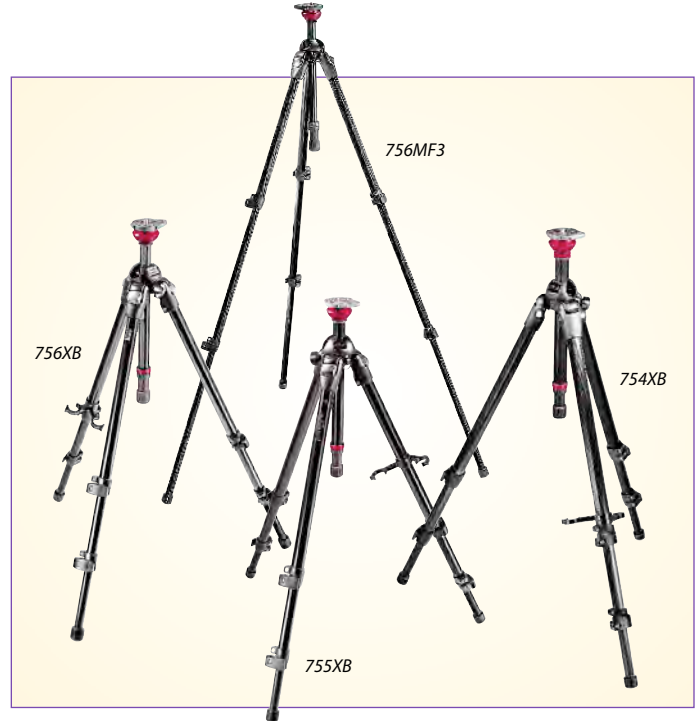

MDeVe MagFiber Tripods

756MF3 MDeVe MagFiber

Video Tripod (Mfr # 756MF3; B&H # BO756MF3)

The 756MF3 is the most innovative tripod of the MDeVe series due to the combination of low weight (Carbon Fiber for the legs/ Magnesium die casting) and high load capacity materials used for its construction. Its unique, patent-pending aluminum center column construction and precision-machined red anodized aluminum includes a built 50mm leveling ball system locked by a detachable rotating grip built at the bottom of the center column, which allows the camera operator to level the camera and even adjust its height without needing to make micro adjustments to each individual tripod leg. The castings of the 756MF3 are constructed of Magnesium to reduce the weight. The crown design also allows the center column to be horizontally mounted**395.95**

755MF3 MDeVe MagFiber

Video Tripod (Mfr # 755MF3; B&H # BO755MF3)

Same as 756MF3 but with a higher load capacity**452.95**

745MF3 MDeVe MagFiber

Video Tripod (Mfr # 745MF3; B&H # BO745MF3)

Two stage tripod made made using locking collars in magnesium and legs tubes in carbon fiber to provide better torsion rigidity and less weight during transportation**365.95**

MDeVe Aluminum Tripods

745XB MDeVe Aluminum Video Tripod (Mfr # 745XB; B&H # BO745XB)

Two stage aluminum tripod specifically geared towards the "on-the-go" videographers looking for a simple, straightforward, and affordable tripod without sacrificing the key virtue of stability. With a maximum load capacity of 13.2 lb, the 745B is designed to handle payloads commonly associated with Mini DV or DVCAM. An integrated 50mm leveling ball allows for quick set up with $\pm 15^\circ$ of leveling capability. Ideal for travel, it quickly folds up to a compact 24.8" and weighs only 5.3 lb. It has a maximum working height of 54.3" and can provide support as low as 8.7" with all three legs opened to a full 90°**213.95**

755XB MDeVe Aluminum Video Tripod (Mfr # 755XB; B&H # BO755XB)

Designed for professional videographers, this is an extremely versatile tripod, ideal for Mini DV camcorders. It is made entirely from aluminum, and has a removable center column with built-in 50mm leveling ball and bubble spirit level that can easily be re-fitted as a lateral arm. This allows the camera to be offset from the leg position, and is the simplest way to shoot a subject from directly overhead**254.95**

756XB MDeVe Aluminum Video Tripod (Mfr # 756XB; B&H # BO756XB)

Professionals will love this extremely compact and light aluminum video tripod. The tripod has an easily removed centre column provided with a 50mm leveling ball and spirit level. Perfectly supports most Mini DV camcorders.....**216.95**

MDeVE SERIES



Right Angle Bracket for Leveling Center Column (Mfr # 553; B&H # BO553)

The Right Angle Bracket is designed to be used with a "leveling center column" in horizontal orientation (e.g. 555B, 556B Leveling Column). This simple L-bracket makes it possible to mount any tripod

head in a normal horizontal position parallel to the ground, even when using the column in horizontal position. It has 3/8" male and female tripod and head connections, and a bubble level to make leveling easier and faster.....**57.50**



MDeVE SERIES FEATURES:

1. Tripod-to-head connection via a disc with 3/8" male thread, built-in spirit level and three grub screws for secure locking mountings.
2. Mounted on a built-in 50mm half bowl levelling system (on 745B and 745MF3 tripods).
3. Single tube leg profile made of round-section aluminium or carbon fiber.
4. Four different leg angle settings.

	756MF3	755MF3	745MF3	745XB	755XB	756XB
Closed Length	23.4"	26.6"	24.8"	24.8"	26.6"	21.9"
Minimum Height	21.5"	8.7"	8.7"	8.7"	19.1"	16"
Maximum Height	46.9"	54.7"	52.5"	54.3"	58.3"	47.4"
Weight	4 lb.	4.6 lb.	4.4 lb.	5.3 lb.	6.2 lb.	4.4 lb.
Load Capacity	8.5 lb.	15.4 lb.	13.2 lb.	15.4 lb.	15.4 lb.	8.8 lb.
Dolly	3127/3137	3127/3137	3127/3137	3127/3137	3127/3137	3127/3137
Spreader	3155	3155	3155	3155	3155	3155
B&H #	BO756MF3	BO755MF3	BO745MF3	BO754XB	BO755XB	BO756XB
Price	395.95	452.95	365.95	213.95	254.95	216.95

MONOPODS

The monopod is an important part of every videographer's support equipment. Besides the tripod, the monopod is the best way to hold a camcorder in situations where space is limited, the quantity and weight of the equipment carried on location needs to be kept to a minimum, or set-up speed is needed.

Fluid Video Monopod (Mfr # 560B; B&H # BO560B): A portable solution for smooth shooting with Mini DV and HDV cameras in confined spaces absorb normal body vibrations. The three pivoting, retractable feet ensure a firm footing while the quick release tilt top with angle lock knob lets you frame more creatively.....**148.95**

Video Monopod (Mfr # 557B; B&H # BO557B): Stable three-section professional monopod featuring flip lock levers and a sliding camera plate adapter to adjust the camera's center of balance. Ideal for ENG style camcorders**106.95**

Video Monopod (Mfr # 558B; B&H # BO558B): Light and compact three-section professional monopod with flip lock levers and a sliding camera plate to adjust the camera's center. Ideal for DVCAM and Mini DV camcorders**101.95**

Video Monopod (Mfr # 559B; B&H # BO559B): A lightweight, compact 4-section monopod with flip lock levers, and a built-in quick release mechanism for easy mounting and removal of the camera. Ideal for small and very compact Mini DV camcorders.....**79.95**



	560B	557B	558B	559B
Max. Height	65.5"	64.6"	62.6"	63.3"
Folded Length	26"	26.3"	25.6"	21.6"
Load Capacity	4.4 lb.	26.4 lb.	17.6 lb.	9.9 lb.
Leg Sections	4	3	3	4
Weight	1.5 lb.	2.4 lb.	2.4 lb.	1.2 lb.

ACCESSORIES

DOLLIES

Folding AutoDolly (Mfr # 3156; B&H # BO3156)

Single lever braking system controls all three 3.1" wheels. Includes 3/8" attachment which allows you to fix a head for low angle shooting. It folds legs for transporting and storage. Designed for Manfrotto's 3068, 3193, 3185, 3182, 351MVB2, 351MVCF, 515MVB, 525MVB, 532ART, 542ART**189.95**

Video Dolly (Mfr # 3067; B&H # BO3067)

Heavy duty, super sturdy dollies are designed for use with large still and video tripods. They feature large 5" individually braked wheels with cable guards. Folds for transporting. Designed for Manfrotto's 3068.....**274.95**

Video Dolly (Mfr # 3127; B&H # BO3127)

Designed for light and medium weight tripods. The 3" wheels have a sure-lock feature that raises the wheels free of the ground so that the dolly rests on separate feet. Designed for Manfrotto's 3221WN, 745XB, 745MF3, 755XB, 755MF, 756XB, 756MF3**108.95**

Portable Dolly (Mfr # 3198; B&H # BO3198)

Same as 3067 Dolly with ability to accept spiked tip tripods. Designed for Manfrotto's 3182, 351MVB2, 351MVCF**264.95**

Basic Dolly (Mfr # 3137; B&H # BO3137)

Everything that the 3127 has with the addition of variable spread to the legs. Suitable for standard and spiked feet. Designed for Manfrotto's 3221WN, 745B, 745MF3, 755B, 755MF, 756XB, 756MF3**132.95**

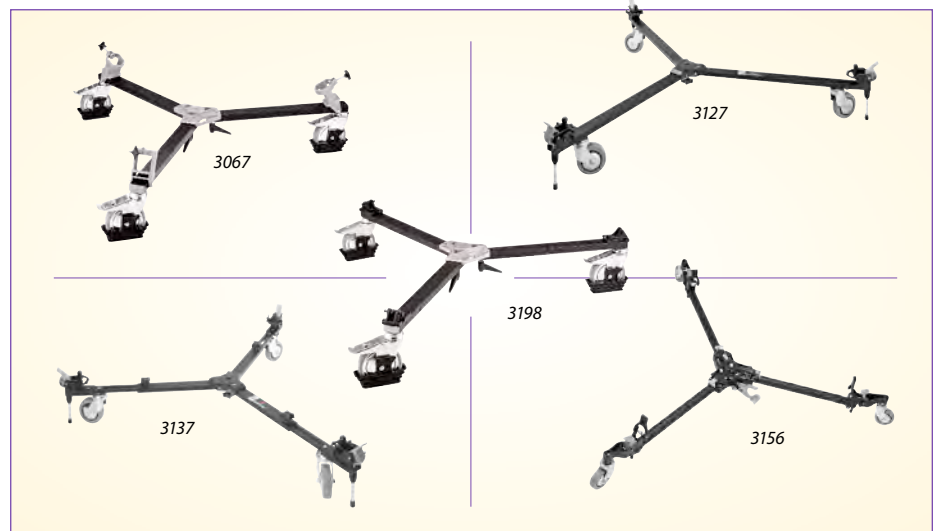

STRAPS

Quick Action Strap (Mfr # 401N; B&H # BO401N):

A quick and easy padded accessory for carrying your tripod. The shorter straps fasten to one of the tripod legs, the longer, adjustable quick-release straps bind the remaining legs together.....**49.95**

Short Strap (Mfr # 3044TSB; B&H # BO3044TSB):

A simple 2" wide loop strap with an adapter and a spring clip that makes attaching and detaching the strap from the tripod easy. It features a single-fixing system whereby the hook attaches to the tripod spider and loops around legs**29.95**

Short Strap (Mfr # 3447; B&H # BO3447):

Same as above, but with a narrower (1.57") black rubberized fabric.....**29.50**

Long Strap (Mfr # 3044; B&H # BO3044):

A basic 2" wide adjustable strap. A spring clip fastens quickly to the steel ring at the shoulder of the tripod, and a closed loop goes around the feet of the tripod and tightens to grip them securely.....**29.95**

Long Strap (Mfr # 3044NAR; B&H # BO3044NAR):

Same as above, but with a narrower (1.57") black rubberized fabric.....**29.95**

SPREADERS

Tripod Spreader for Spiked Feet

(Mfr # 3138; B&H # BO3138): Universal tripod spreader with variable diameter width controls from 31.5" to 51.2". It accepts spiked tip tripod. Designed for the 3193, 3185, 3182, 351MVCF**68.95**



Tripod Spreader (Mfr # 3155; B&H # BO3155)

Universal tripod spreader with variable diameter width controls from 31.5" to 51.2". Designed for Manfrotto's 3221WN, 745XB, 745MF3, 755XB, 755MF, 756XB, 756MF3.....**54.50**

Low Angle Stabilizer (Mfr # 3427; B&H # BO3427)

Designed to increase stability only for "floor-level" working positions. Quickly fitted between the 3138/3155 spreader and the head locking system, it gives total rigidity with minimal torque movement even on fast pans. Designed for Manfrotto's 515MVB and 525MVB tripods.....**CALL**

Mid Lever Spreader (Mfr # 3189; B&H # BO3189)

Designed to fit the mid level leg joint casting of 3193, 3185, 3182, 351MVB2, 351MVCF tripods to provide additional rigidity and structural support**41.95**

Mid Lever Spreader (Mfr # 531SPRB; B&H # BO531SPRB)

Designed to fit the mid level leg joint casting of the 515MVB and 525MVB tripods to provide additional rigidity and structural support. The spreader braces are telescopic.....**59.50**

"Squid" Mid Lever Spreader (Mfr # 530SPRB; B&H # BO530SPRB)

Fits the mid-level leg joint casting to provide additional rigidity and structural support. Unlike most spreaders, the innovative "Squid" lets you fine-tune the spreader brace angle to perfectly suit your working position. In combination with this continuous angle adjustment, you can use the quick click-stop arm length presets for rapid, precise operation.....**209.95**

ACCESSORIES

Tripod/Monopod Feet

Reversible rubber/metal spiked feet supplied with a dedicated fixing tool. The spike is made of a special hard stainless steel alloy extremely resistant to corrosion.

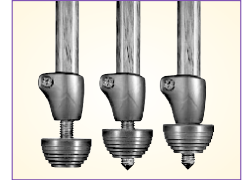

Set of 3 for 3221WN, 745XB, 745MF3, 755XB Tripods (Mfr # 055SPK2; B&H # BO055SPK2)**28.95**

Set of 3 for 756XB Tripod (Mfr # 190SPK2; B&H # BO190SPK2)**31.95**

Set of 3 for 756MF3 Tripod (Mfr # 440SPK2; B&H # BO440SPK2)**32.95**

Set of 3 for 3443 Tripod (Mfr # 441SPK2; B&H # BO441SPK2)**33.95**

For 559B Monopod (Mfr # 449SP2; B&H # BO449SP2)**16.95**

For 558B Monopod (Mfr # 676SP2; B&H # BO676SP2)**16.95**

Suction Cup/ Retractable Spike Feet

A rubber suction cup feet with retractable stainless steel spike. The suction cup increases the footprint of the tripod by almost 20 times, giving much greater stability when needed. The feet can be removed and replaced at will.

Set of 3 for 3221WN, 745XB, 745MF3, 755XB Tripods (Mfr # 055SCK2; B&H # BO055SCK2)**54.50**

Set of 3 for 756XB Tripod (Mfr # 190SCK2; B&H # BO190SCK2)**49.95**

Set of 3 for 756MF3 Tripod (Mfr # 440SCK2; B&H # BO440SCK2)**54.50**

Set of 3 for 755MF3 Tripod (Mfr # 441SCK2; B&H # BO441SCK2)**52.50**

Spike Foot Shoes (Mfr # 565; B&H # BO565)
Set of 3 for 3186, 3193, 3182, 351MVB2, 351MVCF, 515MVB, 525MVB tripods**19.95**

Surveyors Spiked Foot (Mfr # 3257; B&H # BO3257)
Rubber foot with retractable metal spike for monopods**13.95**

All-Weather Tripod Shoes (Mfr # 230; B&H # BO230) Set of three 5.5" shoes that attach to tripod feet or monopods to provide stability in snow, mud or soft ground**19.95**

529B Hi-Hat (Mfr # 529B; B&H # BO529B)

Get shots from the tightest or lowest of locations - and thanks to the built-in spreader, you can use the 529B on any even surface. The feet are rubber-padded to protect delicate surfaces and have a hole, so that it can be screwed to a ladder, apple-box or a sheet of wood. Recommended for the 526, 519 (with 3426 adapter), 516 (with 500BALLSH adapter), 3460 (with 500BALLSH adapter), and 501HDV (with 500BALLSH adapter)**189.95**



Mini Ball Head LCD (Mfr # 482LCD; B&H # BO482LCD)

A swivel mounting accessory that can be attached to the bottom of LCD or TFT monitors so you can mount the monitor to the top of the camera by using the "hot shoe" located on the top of the most camcorders**46.95**

Super Clamp without Stud (Mfr # 2915; B&H # BO2915): This universal clamp can be securely mounted on any tube from 0.5" to 2.1". Includes wedge inserts for better grip**24.95**

Monitor Holder (Mfr # 3152; B&H # BO3152): Designed to hold a monitor mounted on a tripod by using a standard 16mm stud. Straps hold monitor securely in place**46.95**

100mm to 75mm Adapter (Mfr # 3426; B&H # BO3426): A precision-engineered unit that converts all Manfrotto 100mm bowl tripods into a 75mm bowl**34.50**

HYDROSTATIC ARMS



Mini Hydrostatic Arm (Mfr # 814; B&H # BO814): The shortest arm at 5.1", it is also the most powerful. The pivoting pin is threaded with 1/4-20" and 3/8" studs so it can be attached to the top of a video camera to support a small monitor or other video accessory with an exceptional load of 7.7 lbs.**159.95**

Small Hydrostatic Arm (Mfr # 819; B&H # BO819): This arm spans 7", and supports up to 4.85 lbs. It is the ideal companion for attaching a video monitor to a camera or using as a flag support. Like the Mini Arm, the pivoting pins are 1/4-20" and 3/8" threaded with one side offering a platform to provide a larger footprint for the equipment being supported by the arm**169.95**

Medium Hydrostatic Arm (Mfr # 823; B&H # BO823): This arm features 5/8" and 1/4" pins to support larger and heavier items. One of the two pins is hex shaped to mate perfectly with Manfrotto's Super Clamp. With a total length of 9.25", the 823 is ideal to position lighting fixtures or cameras virtually anywhere. A ball pivot encapsulated in a hydraulic oil-filled chamber enables the arm to be locked in position with only a gentle turn of the knob**196.95**

BALL LEVELLERS

100mm Half Ball (Mfr # 3141BALL; B&H # BO3141BALL)
Half ball for levelling video heads on tripods equipped with 100mm bowl**44.95**

75mm Half Ball (Mfr # 3284; B&H # BO3284)
Half ball for levelling video heads on tripods equipped with 75mm bowl**46.50**

100mm Short Half Ball (Mfr # 500BALLSH; B&H # BO500BSH)
Complete with a short locking handle to mount flat-base heads to the 529B Hi-Hat**49.95**

75mm Short Half Ball (Mfr # 520BALLSH; B&H # BO520BSH)
Complete with a short locking handle to mount all Manfrotto flat-base heads to any 75mm bowl tripod including the 529B Hi-Hat (with optional adapter 3426)**46.95**



VIDEO REMOTE CONTROLS

Manfrotto's video camera remote control units put the essential commands of Sony, Canon and Panasonic cameras at your fingertips. Ideal for use with a video tripod & head, monopod, Fig Rig, jib arm, crane or alternative support system. Pan bar versions (which integrate directly with your video head) offer the advantage of allowing you to operate both camera movement and recording/zoom functions with the same hand without having to touch the camera itself; helping eliminate shake and unwanted vibration from your shooting. Clamp versions reduce the number of buttons and controls to the bare minimum, but where you use them is limited only by your imagination. They can be attached to anything from tubes, pipes, table tops, Fig Rigs, steering wheels, handlebars, hang-glidors or almost anything else.

523PRO Professional Remote Zoom Control for Sony and Canon DV/HDV Camcorders

Features a record/stop button, a power on/ standby button, three different zoom speed control buttons (slow, medium and fast) and a push auto focus button. The zoom wheel can be used to control one of the three preset, maximum zoom speeds or a customizable maximum speed which you can set to exactly the level you want. For all zoom



speeds you can choose between progressive zoom or fixed zoom speed. The LED shows you which speed you have selected. No matter what you choose, you can easily repeat zooms in subsequent takes of the same shot. The 523PRO also allows you to set left- and right-handed operation. Achieve in focus images when working in manual focus mode. You can also use the manual focus in and out buttons and change the focus direction. 523PRO does not come with any parts to fit to the head, instead utilizes the pan bar clamp that comes with all Manfrotto heads. (Mfr # 523PRO • B&H # B0523P)**390.95**

522P Remote Control for Panasonic AG-DVC-30, AG-DVC80, AG-DVX100A/B and AG-HVX200

A dual circuit, progressive zoom remote control unit built into a video head pan bar suitable for the 501HDV, 503, 516, 519 and 526 video heads. The dual circuit allows you to choose between a zero power consumption "analog" mode for basic functions (record/stop and progressive min-max zoom via a professional zoom wheel) and a 3 AA battery-powered, advanced, customizable "digital" mode. The digital mode gives you the record/stop function, and the zoom wheel can be used to control one of three preset maximum zoom speeds or a customizable maximum speed which you can set to exactly the level you want. The 522P also allows you to set left- or right handed operation by changing zoom wheel direction. 522P does not come with any parts to fit to the head, but instead utilizes the pan bar clamp that comes with all Manfrotto heads. (Mfr # 522P • B&H # B0522P)**69.00**



PADDED TRIPOD BAGS



Mini Air Bag (Mfr # MBAGD; B&H # BOMBAGD)

A simple unpadded rucksack-style bag for small tripods. It has a bungee cord top opening and adjustable straps, and comes in resistant nylon**15.95**

27.5" Tripod Bag (Mfr # MBAG70; B&H # BOMBAG70)

An unpadded tripod bag that is designed to carry tripods with heads up to 27" long. A zipper extends down the length of the bag, and a padded end cap offers tripod head protection**41.95**

31.5" Tripod Bag (Mfr # MBAG80; B&H # BOMBAG80)

Same as above, but slightly larger to carry tripods with heads up to 31" long**49.95**

31.5" Padded Tripod Bag (Mfr # MBAG80P; B&H # BOMBAG80P)

An asymmetric tapered bag with Thermoform padding that holds the tripod in place and protects it. Carries tripods with heads up to 31" long**74.95**

35.4" Padded Tripod Bag (Mfr # MBAG90P; B&H # BOMBAG90P)

Similar to the above, but slightly larger. Bag can be hand-carried horizontally by the side handle, vertically by the end handle or shoulder-carried using the included shoulder strap. Carries tripods with heads up to 35" long**99.95**

39.4" Padded Tripod Bag (Mfr # MBAG100P; B&H # BOMBAG100P)

Same as above, but slightly larger to carry tripods with heads up to 39" long**109.95**

47.2" Padded Tripod Bag (Mfr # MBAG120P; B&H # BOMBAG120P)

Same as above, but slightly larger to carry tripods with heads up to 47" long**124.95**

VIDEO REMOTE CONTROLS

Manfrotto is the first company to offer a single unit that control both the Fujinon and Canon interchangeable lenses used by professional camcorders. The Intelligent embedded system that allows it to automatically recognize and communicate with the lens you connect it to is what sets Manfrotto's Lens Controls head and shoulders above the rest. In other words: more flexibility at a lower investment, less gear to carry around, less to go wrong — all backed up by Manfrotto's truly worldwide service and support network.

524CFi (Mfr # 524CFi; B&H # BO524CFi)

Intelligent Zoom Remote Control for ENG Lenses

A pan bar-mounted remote control unit for Canon and Fujinon video camera lenses with intelligent circuitry and programming to differentiate between the two. It offers an easy-to-operate progressive zoom, record/stop and RET (return - plays back last 3 seconds of footage then stops at the last recorded frame ready to record again). The red dial allows you to quickly and easily limit the maximum zoom speed to avoid too-fast transitions while the zoom direction switch lets you change from left-right to right-left zooming.....**384.95**

521CFi (Mfr # # 521CFi; B&H # BO521CFi)

Basic Intelligent Zoom Remote Control for ENG Lenses

The 521CFi offers all the functions of the 524CFi in a smaller clamp control, and is suitable for use with the Fig Rig, with jib arms and in a wide variety of other shooting setups. This allows you to take full advantage of the latest compact HD camcorders with interchangeable lenses. It offers easy-to-operate progressive zoom, record/stop and RET. A small side-mounted dial allows you to quickly and easily limit the maximum zoom speed to avoid too-fast transitions while the zoom direction switch (also on the side of the unit) lets you change from left-right to right-left zooming**259.95**

524AX (Mfr # 524AX; B&H # BO524AX)

Zoom Remote Control for Angenieux ENG Lenses

Professional DV cameras continue to evolve and borrow many of the features found on the very high-end ENG cameras including removable manual lenses. Using the same popular pan-handle design of the 523PRO and 522P remotes, Manfrotto offers a zoom remote control for Angenieux ENG lens. The 524AX comes with a built-in 35.4" 8-pin cable to automatically adapt to the 8-pin connection found on most analog ENG lenses.....**372.95**



Video Remote Control Accessories

Remote Pan Bar Adapters: A pan bar adapter kit that connects the Manfrotto remote control to video heads from other manufactures. Available for Fluid Heads with pan bar socket diameter:

12mm <small>(Mfr # 522PB12; B&H # BO522PB12)</small>	39.95	18mm <small>(Mfr # 522PB18; B&H # BO522PB18)</small>	41.95
13mm <small>(Mfr # 522PB13; B&H # BO522PB13)</small>	39.95	22mm <small>(Mfr # 522PB22; B&H # BO522PB22)</small>	36.95
14mm <small>(Mfr # 522PB14; B&H # BO522PB14)</small>	39.50	25mm <small>(Mfr # 522PB25; B&H # BO522PB25)</small>	36.95
16mm <small>(Mfr # 522PB16; B&H # BO522PB16)</small>	39.50	30mm <small>(Mfr # 522PB30; B&H # BO522PB30)</small>	36.95

Rain Cover for Remote Control (Mfr # 523RC; B&H # BO523RC): Waterproof cover for Manfrotto 522 and 523 Remote Control Series supplied with a crystal clear vinyl panel to allow to view the remote control button during the shooting session. The cover slips quickly over the remote pan bar to protect it from rain or sudden showers.....**29.95**

Standard Remote Control Cable (Mfr # 522SCA; B&H # BO522SCA): 9.8'. Replacement.....**9.95**

Remote Control Cable Extension (Mfr # 522EXTC; B&H # BO522EXTC): 35.4'. Replacement.....**45.95**

Remote Control Cable Extension (Mfr # 522EXTC30; B&H # BO522EXTC30): 98'. Replacement ..**107.95**

DOLLIES

Doorway Dollies

For years the Doorway Dolly has proven its versatility on stage and location. Quick change pneumatic wheels are standard equipment. Combination Track/Stage Wheels allow for running on hard surfaces. The Dolly can easily be fitted with Matthews Hot Buttons for use on straight or curve track.

The platform is fitted with a recessed camera tie down and is carpeted for a non-slip, low maintenance surface. The Doorway Dolly will move through a full range of travel with either the Push Bar or Pull Bar.

Load it with gear to get to the location with ease! The platform can be flipped over for even lower camera positioning. Ground clearance is 9" or 3" when inverted. The removable side boards add an extra 10" per side for increased platform width. The wheelbase is 28 1/4" wide and the platform length is 51". Hot Buttons can be easily installed to accommodate standard 24.5" width track. Weight capacity is 800 lbs.



Doorway Dolly with Turret



Doorway Dolly (Mfr # 395100; B&H # MADDW) Weighs 117 lbs.....**1769.95**

Doorway Dolly with Turret (Mfr # 395043; B&H # MADDWT) Provides a 360° swing of both the camera mount and operator with all the functions of the standard dolly system. Mitchell mount and single operator seat are standard. It weighs 197 lbs.**4893.50**

Hot Buttons (Mfr # 395011; B&H # MAWHB) Set of 4 track wheels for straight or curved track.....**704.95**

Straight Track Wheels (Mfr # 395001) Self-contained bearings designed to work on hard surfaces or 1 1/2" diameter straight track only**CALL**

Briefcase Dolly

Airline transportable, the Briefcase Dolly is easy to set up, and totally self contained with casters, track wheels, locking push bar and pull handle, all in a durable case which opens into the dolly platform. Use with casters to shoot or haul equipment on regular surfaces, or use with track wheels to run on regular track, focus track, or even PVC or metal pipe. It will run on straight or curve track and will easily support up to 500 lbs. Weighs 59 lbs., measures 6 x 19.5 x 29".

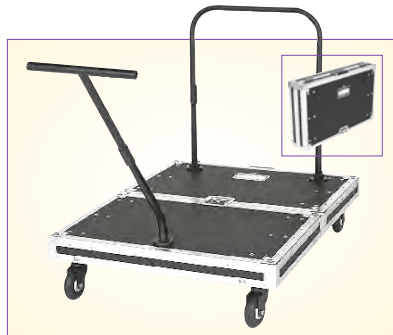

Briefcase Dolly (Mfr # 395022; B&H # MADBC)**2699.95**
Wheel Assembly for Briefcase Dolly (4 are needed) ea.....**CALL**

Western Dolly with Pop-Off Wheels

The Western Dolly has a heavier-duty platform than the Doorway, and offers a maximum capacity of 1200 lbs. The wider and longer platform, wider tires and extended wheelbase provide a significantly smoother ride. Pop-Off wheels allow quick removal and easy storage. The axle is captivated into the wheel assembly to prevent the axle from becoming separated from the wheel upon removal. It has a 52" wheel base, with an overall length of 76". The platform size is 48" wide by 66" long. Tire pressure is 16-22 lbs.



Used as an equipment transportation vehicle or as a camera platform, the Western Dolly provides reliable, heavy duty, steady support at a reasonable price. As it is impossible to anticipate the manner in which the dolly will be

loaded or the slope of the terrain on which it will be used, Matthews has made the capacity of each axle match the total capacity of the dolly, making the Western Dolly the strongest dolly of its type.

A turret assembly that allows mounting of two seats and a complete camera configuration supported by a Mitchell Base is also available.

Doorway Dolly (Mfr # 395047; B&H # MADR) Complete with pop-off wheels, push bar and push handle**2213.50**
Push Bar Tilt Adapter (Mfr # 395005); 34°, set of two.....**CALL**

Round-D-Round Doorway Dolly

A next generation doorway dolly, the Round-D-Round Doorway Dolly (51" long and 28.25" wide) offers all-wheel steering for greater turning flexibility, and can negotiate an extremely tight circle



of 6'. The camera operator is able to mount into six different fixed locations. Steering with the push/pull bar is possible from either ends of the dolly. In addition to being able to mount the seat directly onto the post, the included offset arm can be installed to give the camera operator more choices for seating positions and camera angles.

An optional second seat and offset arm offers the ability of having a second person seated on the dolly. This provides virtually unlimited camera and operator positioning as the dolly rolls on track with either Hot Buttons or the Centipede. Of course, using the dolly directly on the ground with the standard pneumatic rubber tires is another option. With a load capacity over 1100 lbs., this excellent choice for stage or location is carpeted for a non-slip low-maintenance surface.

Round-D-Round Dolly (Mfr # 395300; B&H # MARDRDDW)**2599.95**
Round-D-Round Seat (Mfr # 395310; B&H # MASRRDDW).....**257.50**
Secondary Offset Arm (Mfr # 395302; B&H # MASSOSA).....**49.95**

MATTHEWS

DOLLIES & TRACKS

Bazooka

The Bazooka is based on the international, industry-standard Elemac mounting system. Lightweight and easily mounted to any Doorway Dolly with just three bolts, the Bazooka adjusts from 24" to 39 1/4".



Whether used "free-standing" or in conjunction with any other camera dolly, the Bazooka reveals a myriad of creative imaging possibilities when using the Elemac mounting plate and a variety of side arms and adapters. The Bazooka offers a wide range of camera mount configurations at very affordable prices.

- Bazooka** (Mfr # 377702; B&H # MABAZ) **1054.95**
- Elemac to 100mm Bowl** (Mfr # 845120; B&H # MACBCA) **339.50**
- Elemac to Mitchell Adapter** (Mfr # 515024; B&H # MAEMA) **394.50**
- Elemac to Elemac Arm** (Mfr # 515021; B&H # MAEAB) **299.95**
- Elemac Mounting Plate** (Mfr # 515003; B&H # MAEMP) **146.95**

Centipede

A fast, efficient way to achieve a smooth dolly track shot. Can be used with most camera dollies less than 34" in width. Each truck consists of 8 wheels, 32 per set, staggered in position. Wheels will perform on older, less than perfect track as well as newer, precision track systems using 1 1/2" diameter rails. The Centipede's wheels will remain round under normal conditions. The suggested working load range is 200 - 1500 lbs. Dollies with less than a 46" wheel base will work well with the 10' diameter curve track. An optional carrying case is available to protect the Centipede, and make transporting it easier



- Centipede** (Mfr # 395200; B&H # MACX): Set of 2. Weighs 27.5 lb **2156.50**
- Centipede Case** (Mfr # 395199; B&H # MACCO): Weighs 31.2 lb **774.95**



Lenny Levelers

The Lenny Leveler has been designed to stabilize and level the Doorway Dolly. The stabilizer arms relocate the load base from the pneumatic tires to

provide an increased footprint and more stable platform. The extended footprint is especially desirable when a jib arm is mounted on the Doorway Dolly, as it effectively increases the center of gravity.

- Lenny Levelers** (Mfr # B395101; B&H # MALL): Set of 4. Weighs 40 lb **654.50**

Dolly Track

Matthews manufactures heavy wall and stainless steel Dolly Track. Heavy wall is manufactured from 1 1/2" diameter steel tube and is chrome-plated to protect it from negative environmental effects. It is slightly less expensive than stainless steel track. Stainless steel track does not require plating. Due to the inherent characteristics of the material, it is impervious to the elements.

(Note: Matthews doesn't recommend that the two types of track be used together.) The chrome plating used on the Heavy Wall can create size buildup and the finished diameter may be slightly larger. This can create a noticeable "bump" at the joint. Matthews curved tracks are available to complete 10', 20' and 70' diameter circles. Be advised that most dollies will not navigate the 10' circle without the addition of a multi wheeled device such as the Matthews Centipede.

Four pieces of 90° curve track are needed to complete a circle. Eight pieces are required for 20' diameter and 16 pieces for the 70' diameter circle. All Matthews Dolly Track is rated to a maximum payload of 1200 lbs. at the industry standard of 24.5" center to center track width.



Straight Track - Heavy Wall

- 4' Heavy Wall** (Mfr # 399735; B&H # MATS4): 4' section, 23.5 lbs **356.50**
- 8' Heavy Wall** (Mfr # 397055; B&H # MATS8): 8' section, 37 lbs **469.50**
- 10' Heavy Wall** (Mfr # 399736; B&H # MATS10): 10' section, 45 lbs **523.95**



Curved Track - Heavy Wall

- 8' Heavy Wall** (Mfr # 397050; B&H # MATC8): 20' diameter, 30 lb **489.95**
- 10' Heavy Wall** (Mfr # 397083; B&H # MATC10): 70' diameter, 41 lb **699.95**
- 90° Tight Radius** (Mfr # 397081; B&H # MATC90D): 10' diameter, 21 lb **654.50**

Straight Track - Stainless Steel

- 4' Stainless Steel** (Mfr # 397070; B&H #): 4' section, 22.5 lbs **CALL**
- 8' Stainless Steel** (Mfr # 397065; B&H #): 8' section, 36 lbs **CALL**

Curved Track - Stainless Steel

- 8' Stainless Steel** (Mfr # 397059; B&H #): 20' diameter, 30.5 lb **CALL**
- 90° Tight Radius** (Mfr # 397080; B&H #): 10' diameter, 23 lb **CALL**

Heavy Wall Starter Track (Mfr # 397054; B&H # MATS): Weighs 7 lb **231.95**

Track Wedge (Mfr # 399734; B&H # MAWT): Used to level track and to drive as a wedge to create perfect vertical or horizontal conditions **2.95**



CAMERA SUPPORT — CAR RIGS

Hood Mount Kit

Widely used in the television and movie industry, Matthews' auto mount systems enable construction of most any type of auto or motorcycle mounts. Available in separately or in kits, any number of heads will mount on the system. The Hood Mount Kit will also work as a rear deck, roof, and wheel mount of almost any still, film or video camera.

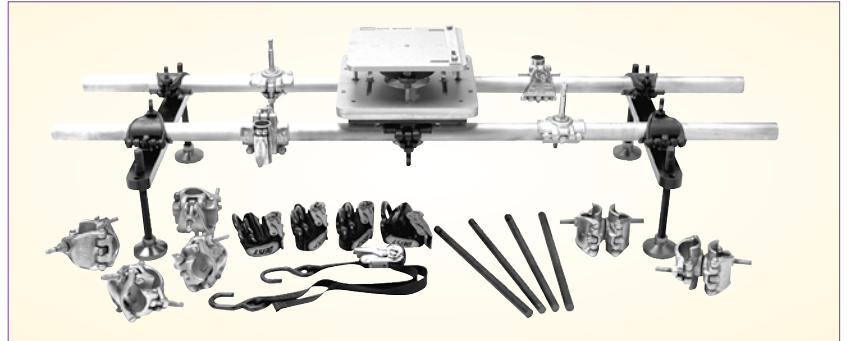

Hood Mount Kit (Mfr # 415166; B&H # MAHMK)

Kit includes a low profile leveling head, slide plate, two work horse clamps, four standard screw jacks with large leveling pads, four extended screw jacks with large leveling pads, five tie down straps, two baby grid clamps, two junior grid clamps, four 90° clamps, and two swivel clamps.....**2399.95**

Low Profile 4-Way Leveling Head (Mfr # 415151; B&H # MALPLH)

Has 4 independent screw levelers for precise leveling of almost any still or video camera used in this system**879.95**

Side Mount Kit Hostess Tray (Mfr # 415167; B&H # MASMK)

Allows basic mounting and level positioning of a camera onto the side of a motor vehicle. The kit includes a side mount bracket, low profile leveling head, two tie down straps and four screw jacks with small leveling pads.....**1379.95**

Side Mount Bracket Assembly Only (Mfr # 735161; B&H # MASMA)

Can be used as a second rig that accepts the camera and leveling head, for opposite angle shots while mounted on a motor vehicle.....**879.95**

Slide Plate (Mfr # 735152; B&H # MASP)

For mounting a camera to the side of a motor vehicle. A leveling head gets mounted to the top.....**213.95**

2-Way Tilt Plate (Mfr # 415165; B&H # MATP2W)

Vertical or horizontal tilting camera support for car rigs.....**419.95**

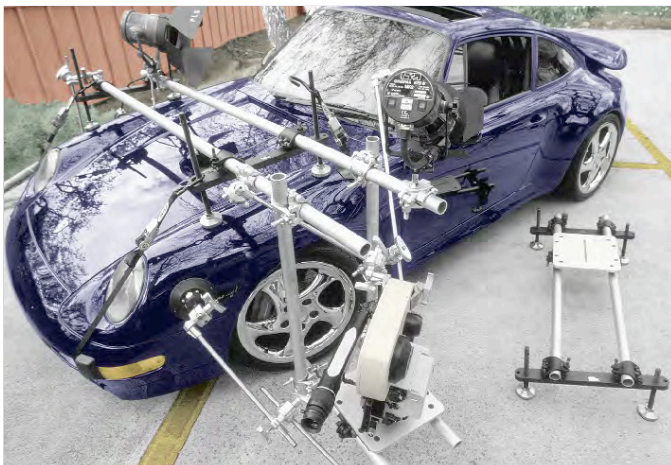

Standard Screw Jack Set (Mfr # 425154; B&H # MASJS)

A set of 4 screw jack extensions, 9" each, for use with the Side Mount Kit. These extensions allow regulation of angle and distance of the camera platform from the vehicle in use. With leveling pads.....**279.95**

Extended Screw Jack Set (Mfr # 425155; B&H # MASJE)

A set of 4 screw jack extensions, 15" each. With leveling pads**304.50**



Work Horse Clamp (Mfr # 425153; B&H # MACWH)

A bar with two pipe clamps. An integral part of the Side Mount Kit and Bracket Assembly**259.95**

Tie Down Straps (Mfr # 735156; B&H # MASX)

Adjustable nylon tie-down strap, with attached "S" Hooks for fastening and securing a frame or bracket**27.95**

Small Leveling Pads (Mfr # 6111100; B&H # MALPS)

To level and stabilize the camera support rig while mounted on a motor vehicle**42.50**

Large Leveling Pads (Mfr # 6084100; B&H # MALPL)

To level and stabilize the camera support rig while mounted on a motor vehicle**69.95**

Horizontal Frame Clamp (Mfr # 415163; B&H # MACHF)

Use in any of eight different positions.....**89.50**

Swivel Grid Clamp (Mfr # 425160; B&H # MACSG)

Grips 1¼ to 1½" pipe diameter. Virtually unbreakable when the ultimate in strength is required. Exceeds tensile strength @16,000 lbs.....**29.95**

Baby Grid Clamp (Mfr # 425157; B&H # MACBG)

Clamps securely on overhead grids, car rigs or camera car rails for the mounting of light fixtures. Can be inverted with the pin mounting into a Grip Head for spanning pipe between 2 stands.....**42.95**

Junior Grid Clamp (Mfr # 425158; B&H # MACJG)

For mounting larger lighting fixtures to overhead grids, car rigs or camera car rails**39.95**

Right Angle Grid Clamp (Mfr # 425159; B&H # MAC90D)

Used for mounting a light, or other grip equipment, at a 90° angle to a grip pipe, or truss. Ends in a 5/8" pin.....**27.95**



CAMERA SUPPORT — GENERAL

Suction Cups

Suction Cups have 5/8" pins (except the 10" Pump Cup). Pump it until the red marker disappears to create an amazing bond to non-porous surfaces. Used for camera shots on car hoods in conjunction with the 4-Way Tilt Plate.

10" Pump Cup (Mfr # 417023; B&H # MASC10)
A heavy duty style without 5/8" pins.....**198.95**

6" Pump Cup (Mfr # 427000; B&H # MAPC)
With 5/8" pin.....**93.50**

4.5" Pump Cup (Mfr # 427005; B&H # MASPC4.5)
With camera mount.....**118.50**

6" Pump Cup (Mfr # 427006; B&H # MASPC6)
With camera mount.....**167.50**

4-Way Tilt Plate

4-Way Tilt Plate (Mfr # 417010; B&H # MASC10MK)
A compact camera mounting unit with tilt adjustment in two planes, allowing the camera to be inverted 180°. The base has a series of mounting holes, or it can be mounted with the 10" suction cup or optional 'C' clamp.....**669.95**

Mounting Kit (Mfr # 417024; B&H # MAAK4WTP)
An adapter that mounts the 4-Way Tilt Plate to the 10" Suction Cup.....**69.95**

Camera Risers

Camera Risers, commonly known as High Hats, raise the camera and head a fixed distance off the dolly or support piece. The units have Mitchell mounting configurations on both top and bottom.

6" Mitchell Camera Riser
(Mfr # 417006; B&H # MACR6).....**523.50**

12" Mitchell Camera Riser
(Mfr # 417012; B&H # MACR12).....**523.50**

Adapters

100mm Claw Ball to Mitchell Flat Base Adapter (Mfr # 815121; B&H # MACBMA).....**388.50**

Elemack to Mitchell Adapter
(Mfr # 515024; B&H # MAEMA).....**394.50**

Mitchell to Elemack Adapter
(Mfr # 515025; B&H # MAAME).....**279.95**



4-Way Leveling Head

Knurled screws allow the positioning of the camera platform to be perfectly level in two planes and adjustable within ±1". Mitchell configuration or specify Elemack thread for mounting.

4-Way Leveling Head
(Mfr # 415063; B&H # MALHMM).....**835.95**

4-Way Leveling Head with Flat Mount
(Mfr # 395063; B&H # MALHFM).....**791.95**

4-Way Leveling Head with Elemack Mount
(Mfr # 725063; B&H # MALHEM).....**879.95**

Bangi

Bangi (Mfr # 417021; B&H # MAMBQ)
Used to offset the camera from the tripod or other mount. Its most common use is extreme tilt shots. It features Mitchell style mounts sliding on aluminum bronze rods. The Bangi will support most camera systems.....**853.50**



High Hats

Designed to provide stable support, High Hat allows the mounting of a video fluid head to get great footage without shakes and vibrations at an extremely low camera angle. Available in a variety of different sizes, ideal to mount it on a board or any other location where you need the use of a video head.

6" High Hat 100mm Claw Ball
(Mfr # 815515; B&H # MAHH6BB100).....**514.50**

6" High Hat with Mitchell Base
(Mfr # 815510; B&H # MAHH6M).....**484.50**

Mitchell Top Plate
(Mfr # 5028; B&H # MAMTP).....**213.95**

Mitchell Camera Nut
(Mfr # 1880; B&H # MAMCN).....**102.95**



P8 PNEUMATIC SYSTEM

The P8 Pneumatic Pedestal is the ideal solution for the budget-minded broadcast studio operation. With a load capacity of 175 lbs., the P8 provides smooth pedestal floor moves through the self-steering system. It easily rolls through doorways with minimum clearance of 28". The pneumatic column can be precisely balanced to allow for a floating camera position. The steering wheel is 19" in diameter and easily steers the cable-shrouded 5.75" diameter dual wheel trucks. Ideal for the budgets of small television or production studios, the P8 provides low angle camera action, while its compact size and ease of maneuverability insure complete control.

P8 Pneumatic Studio Pedestal:

Completely sealed pressure system 1 to 1 ratio (PSI to load) with pressure relief valve at 250 PSI. Standard compressed air is used; 12 pressure differential trim wafers provided. Weighs 302 lbs. and has a maximum load capacity of 175 lbs. (Mfr # 814800 • B&H # MAP8)**12,123.50**



MT1 Heavy-Duty Tripod



With the highest degree of structural integrity and dependability, the MT-1 is used at most of the world's major sporting events. Constructed of high strength aluminum alloy castings and stainless steel, it is finished to withstand the most severe weather. It features a combination leg spike, bolt down pads and spherical ball

feet. It weighs 28 lbs. and has a 265 lb. load capacity.

- ◆ Heavy-duty aluminum construction
- ◆ Mitchell base mount
- ◆ Single extension design
- ◆ Maximum height of 44"

(Mfr # 812170; B&H # MAMT1)**2093.95**

Brass Brake for MT-1 (Mfr # 22421K • B&H # MABMT1)

Simplicity and reliability are the best words to characterize the redesigned MT-1 brake. The brake replaces the original multi-part brake assembly with a single brass plate that has been engineered to provide positive, service-free locking**59.95**



DL-7 Dolly for MT-1 (Mfr # 811171 • B&H # MAD7): A firm, stable platform required for "whip" pans and other rapid camera movements, with no tripod, jitter, twist or swaying**1378.50**

PETER LISAND Lisand Studio Pedestal



The Lisand Studio Pedestal combines strength, rigidity, light weight and low cost, to create an economical alternative to traditionally large, heavy and expensive TV studio pedestals. While its was designed to meet the demands of cable TV, educational and corporate studio communicators, its light weight and compact transport dimensions make it equally at home on the road, in temporary studio locations. The center column of the Lisand Studio Pedestal is equipped with a

sealed, air charged cartridge, providing lift assist for camera payloads up to 50 lbs. The standard, "hi-hat" top, will accept 100mm ball leveling fluid heads of all major head manufacturers. This design permits immediate mounting of the head to the pedestal without first converting or adapting the head to a flat base configuration. Maintaining the head's ball level capability permits fast and simple compensation for any irregularities in the studio floor. Optional hi hat tops are available to accommodate 150mm ball level fluid heads and all flat base head configurations. The Lisand Studio Pedestal, without fluid head, weighs 24 lb. The wheels quickly remove, allowing the pedestal to reduce to a transport size of just 34" long x 12" diameter.

(Mfr# PLSP1 • B&H# PEPLSP1)**1809.95**

DS SERIES FLUID HEADS

DS5 High-Quality Precision Mini-DV Head

Attaches to your MiniDV camera using the industry standard 1/4" + pin attachment and provides a true fluid pan and tilt drag offering smooth movements needed to produce high quality MiniDV productions. Disc-style tilt and pan locks guarantee non-slip rock-solid lock-off shooting positions. 75mm ball levelling which lets you set up your tripod to any position, then quickly adjust your fluid head using the rear-mounted bubble level for perfect horizon setting.

- ◆ Self locking quick release plate with 1/4" + pin with a 20mm sliding range to offset lens/battery payloads.
- ◆ Disc-style tilt and pan locks with rotary control.
- ◆ True fluid action clutch pack.
- ◆ Rear-mounted bubble level combines with 75mm ball levelling system for rapid horizon setting.

DS5 Solo DV Alloy System (Mfr # 1637; B&H # MIDS5SDVAT): System includes the DS5 Fluid Head, Solo DV 2 Stage Alloy Tripod, Pan Handle with Handle Carrier, and the Solo DV Case**949.95**



DS10 Professional HDV System

Similar physical appearance and features as the DS5 fluid head with two selectable counterbalance positions for MiniDV/DVCAM/HDV camcorders with larger lens/battery from 5.5 to 11 lbs. Improved pan and tilt drag adjustments provide a friction boost to the true fluid action. Aids in drag control under high wind or adverse location conditions.

- ◆ Large battery or lens? Sliding quick release plate will offset your load for perfect tilt balance.
- ◆ Direct attachment to a Mini DV camcorder with 1/4" + pin attachment, or attach to Sony-style tripod plate with optional 1/4" and 3/8" screws.
- ◆ Fluid drag plate system with friction boost.
- ◆ 2-position selectable counterbalance control.
- ◆ Calliper-style disc pan & tilt locks. Rotary control guarantees non-slip, rock solid lock-off.
- ◆ Industry-standard 75mm ball levelling with bubble level is a quick means of resetting horizon level without having to adjust or reposition the tripod.

DS10 System (Mfr # 828; B&H # MIDS10AGKQ): Includes DS10 fluid head, lightweight 75mm alloy tripod, non-telescopic above-ground spreader, ENG/EFP tripod rubber feet, pan handle with handle carrier, tripod shoulder strap, and soft case**1049.95**

DS10 ENG System (Mfr # 832; B&H # MIDS10EAGCK): Includes DS10 fluid head, 2-stage 75mm alloy tripod, above-ground spreader, ENG/EFP tripod rubber feet, pan handle with handle carrier, tripod shoulder strap, and soft case (876)**1449.95**

DS10 Solo DV CF System (Mfr # 1511; B&H # MIDS10SDV2): Includes DS10 fluid head, Solo DV 2-stage alloy tripod, pan handle with handle carrier, Solo DV strap, and Solo DV case**1294.95**

DS10 Solo DV Alloy System (Mfr # 1640; B&H # MIDS10SDVAT): Includes DS10 fluid head, Solo DV 2-stage alloy tripod, pan handle with handle carrier, and Solo DV case**1099.95**

DS20 Superior HDV System

As the superior fluid head of the DV range, the DS20 offers 1/4" + pin or 1/4" + 3/8" screw attachments to attach MiniDV or tripod Adapter plates. Adjustable pan and tilt drags provide continuous friction for your flexible applications, while 'flick-of-a-switch' selectable counterbalance lets you tilt balance larger camcorders ranging from 11 to 22 lbs.

- ◆ MiniDV/DVCAM/HDV camcorders to 22 lbs.
- ◆ Fluid drag adjustment provides a friction boost to the true fluid action for high wind or adverse conditions.
- ◆ Camera plate choice: 1/4" + 3/8" screws or 1/4" + pin.
- ◆ Selectable counterbalance system.
- ◆ Rotary control, calliper-style pan & tilt disc lock.
- ◆ Safety lock sliding quick release plate.
- ◆ 75mm ball levelling with rear-mount bubble level.

DS20 Fluid Head (Mfr # 184; B&H # MIDS20): Supports 20 lbs**1159.95**

DS20 System (Mfr # 848; B&H # MIDS20E0GK): Includes DS20 fluid head, 2-stage 75mm alloy tripod, DS ground spreader, pan handle with handle carrier, tripod shoulder strap, and soft case**1549.95**

DS20 Solo DV Alloy System (Mfr # 1643; B&H # MIDS20SDVAT): Includes DS20 fluid head, Solo DV 2-stage alloy tripod, pan handle with handle carrier, and Solo DV case**1349.95**

DS20 ENG System (Mfr # 850; B&H # MIDS20EAGK): Includes DS20 fluid head, 2-stage 75mm alloy tripod, above-ground spreader, ENG/EFP tripod rubber feet, pan handle with handle carrier, tripod shoulder strap, and soft case**1599.95**

DS20 Solo DV CF System (Mfr # 1514; B&H # MIDS20SDV2): Includes DS20 fluid head, Solo DV 2-stage alloy tripod, pan handle with handle carrier, Solo DV strap, and Solo DV case**1499.95**



ARROW SERIES FLUID HEADS

Miller's Arrow Series of fluid heads utilize high-precision die-cast housings, pre-treated with chromate to prevent corrosion and anti-corrosive fixings that contribute to their proven reliability. The fluid module drag system is sealed to ensure consistency even in extreme temperatures, and, combined with additional modules, achieves true variance in drag settings, unlike wind-up drag systems. Soft take-offs, and smooth stops with over-runs are the hallmark of Miller's drag systems. Whether its diagonal shots, precise framing or long tight shots, you are in total control. Miller's variable counterbalance systems combined with a sliding camera platform ensure a quick set-up rather than time-consuming turning required on wind up counterbalance systems. Changing camera configurations in the field are made simple and rebalance is achieved quickly.



Arrow 25 Drag Performance from HDV to ENG

A 100mm true fluid head designed to support the latest generation in acquisition from the film-ready HDV alternatives to the lightweight ENG camcorders weighing up to 30.8 lbs. It features 5-step fluid drag, 4-step spring counterbalance, and a 70mm sliding quick-release camera plate. The LED illuminated bubble level and drag controls are rear mounted for easy operator access and monitoring, and a second rosette is provided for left- or two-handed configurations. For peace of mind, pan and tilt locks utilize caliper disc brakes for reliable, short-throw fixing.

Arrow 25 Fluid Head (Mfr # 1022; B&H # MIA25FH): Holds camcorders weighing up to 30.8 lbs**2573.50**

Arrow 25 1769 System (Mfr # 1769; B&H # MIA25SSAS2S): Arrow 25 fluid head, Sprinter II single-stage alloy tripod, ground spreader, pan handle with handle carrier, and Arrow soft case.....**3899.95**

Arrow 25 1770 System (Mfr # 1770; B&H # MIA25SSAS2SQ): Arrow 25 fluid head, Sprinter II single-stage alloy tripod, mid spreader, tripod rubber feet, pan handle with handle carrier, and Arrow soft case.....**4194.95**

Arrow 25 1773 System (Mfr # 1773; B&H # MIA252SAS2S): Arrow 25 fluid head, Sprinter II two-stage alloy tripod, ground spreader, pan handle with handle carrier, and Arrow soft case.....**4197.95**

Arrow 25 1774 System (Mfr # 1774; B&H # MIA252SAS2SQ): Arrow 25 fluid head, Sprinter II two-stage alloy tripod, mid spreader, tripod rubber feet, pan handle with handle carrier, Arrow soft case.....**4457.95**

Arrow 25 1778 System (Mfr # 1778; B&H # MIA252SCFS2S): Arrow 25 fluid head, Sprinter II two-stage carbon fiber tripod, mid spreader, tripod rubber feet, pan handle with handle carrier, and Arrow soft case.....**4979.95**

Arrow 25 1793 System (Mfr # 1793; B&H # MIA25E3SCFS): Arrow 25 fluid head, SOLO ENG 3-stage carbon fiber tripod, pan handle with handle carrier, Solo shoulder strap, and Arrow soft case.....**3749.50**

Arrow 40 Precision Performer for News Gathering

The Arrow 40 fluid head performance and features evolved from the demanding world of news gathering. Strength, durability and smooth fluid action have been combined in a simple-to-operate fluid head featuring 7 position pan and tilt drag, 4 counterbalance positions to suit all portable ENG camcorders, rear mount controls and backlit illumination on pan/tilt indicators and bubble level. With 7 position pan and tilt drag the Arrow 40 offers the widest range and heaviest drag in its class. From fast-action sports shooting to long, slow pans the Arrow 40 exceeds expectations of precision, quality and features for the ENG operators.

Arrow 40 Fluid Head (Mfr # 1025; B&H # MIA40FH): Holds camcorders weighing up to 35.2 lbs**3359.95**

Arrow 40 1680 System (Mfr # 1680; B&H # MIA40SS2AS): Arrow 40 fluid head, Sprinter II single-stage alloy tripod, ground spreader, pan handle with handle carrier, and Arrow soft case.....**4669.95**

Arrow 40 1681 System (Mfr # 1681; B&H # MIA40SS2ASQ): Arrow 40 fluid head, Sprinter II single-stage alloy tripod, mid spreader, tripod rubber feet, pan handle with handle carrier, and Arrow soft case.....**4671.95**

Arrow 40 1686 System (Mfr # 1686; B&H # MIA402SS2AS): Arrow 40 fluid head, Sprinter II two-stage alloy tripod, mid spreader, tripod rubber feet, pan handle with handle carrier, and Arrow soft case**5244.95**

Arrow 40 1690 System (Mfr # 1690; B&H # MIA402SS2CFS): Arrow 40 fluid head, Sprinter II two-stage carbon fiber tripod, mid spreader, tripod rubber feet, pan handle with handle carrier, Arrow soft case.....**5664.95**

Arrow 40 1709 System (Mfr # 1709; B&H # MIA40E3SCFS): Arrow 40 fluid head, SOLO ENG 3-stage carbon fiber tripod, pan handle with handle carrier, Solo shoulder strap, and Arrow soft case.....**3749.95**



ARROW SERIES FLUID HEADS

Arrow 55 Heavy-Duty Performance for ENG/EFP

The Arrow 55 is a 100mm true fluid head that provides higher load capacity (up to up to 55 lbs.) to suit documentary, lifestyle, and HD productions. It is particularly suited to long-lens applications or Studio EFP configurations. It features 7-position pan and tilt drag, 4-step spring counterbalance positions to suit all portable EFP camcorders, and an oversized 100mm sliding quick-release camera plate. The LED-illuminated bubble-level and drag controls are rear-mounted for easy operator access and monitoring, and a second rosette is provided for left- or two-handed configurations. For peace of mind, pan and tilt locks utilize caliper disc brakes for reliable, short-throw fixing.

- ◆ 7 (plus zero) positions of fluid pan and tilt drag
- ◆ 4 positions of counterbalance
- ◆ Rear mounted controls
- ◆ White illumination of bubble level and indicators for pan and tilt
- ◆ 100mm quick release sliding platform
- ◆ 100mm ball leveling



Arrow 55 Fluid Head (Mfr # 1028; B&H # MIA55FH): Supports camcorders weighing up to 55 lbs.....**4041.95**

Arrow 55 1717 System (Mfr # 1717; B&H # MIA55SS2AS): Arrow 55 fluid head, Sprinter II single-stage alloy tripod, ground spreader, pan handle with handle carrier, and Arrow soft case.....**5456.50**

Arrow 55 1737 System (Mfr # 1737; B&H # MIA55HDSSAS): Arrow 55 fluid head, heavy-duty single-stage alloy tripod, mid spreader, tripod rubber feet, pan handle with handle carrier**5982.95**

Arrow 55 1718 System (Mfr # 1718; B&H # MIA55SS2ASQ): Arrow 55 fluid head, Sprinter II single-stage alloy tripod, mid spreader, tripod rubber feet, pan handle with handle carrier, and Arrow soft case.....**5664.95**

Arrow 55 1741 System (Mfr # 1741; B&H # MIA55HD2SCFS): Arrow 55 fluid head, heavy-duty two-stage carbon fiber tripod, mid spreader, tripod rubber feet, pan handle with handle carrier, and HD soft case.....**6816.50**

Arrow 55 1726 System (Mfr # 1726; B&H # MIA55S2SCFS): Arrow 55 fluid head, Sprinter II two-stage carbon fiber tripod, mid spreader, tripod rubber feet, pan handle with handle carrier, and Arrow soft case**6189.95**

DS SERIES AND ARROW SERIES FLUID HEAD SPECIFICATIONS

	DS5	DS10	DS20	ARROW 25	ARROW 40	ARROW 55
Weight	3.5 lb.	3.7 lb.	3.9 lb.	6.6 lb.	7.1 lb.	7.1 lb.
Load Capacity	0-5.5 lb.	5.5-11 lb.	11-22 lb.	7-30 lb.	15-35 lb.	22-55 lb.
Pan Drag	Fluid drag plate system	Fluid drag plate system with friction boost	Fluid drag plate system with friction boost	5 selectable fluid drag positions + 0	7 selectable fluid drag positions + 0	7 selectable fluid drag positions + 0
Pan Rotation	360°	360°	360°	360°	360°	360°
Pan Lock	Calliper disc brake system	Calliper disc brake system	Calliper disc brake system	Calliper disc brake system	Calliper disc brake system	Calliper disc brake system
Tilt Drag	Fluid drag plate system	Fluid drag plate system with friction boost	Fluid drag plate system with friction boost	5 selectable fluid drag positions + 0	7 selectable fluid drag positions + 0	7 selectable fluid drag positions + 0
Tilt Rotation	+ 90°/ -75°	+ 90°/ -75°	+ 90°/ -75°	± 90°	± 90°	± 90°
Tilt Lock	Calliper disc brake system	Calliper disc brake system	Calliper disc brake system	Calliper disc brake system	Calliper disc brake system	Calliper disc brake system
Counterbalance	Single fixed position	2 selectable positions	Single fixed position	4 selectable positions	4 selectable positions	4 selectable positions
Camera Platform	Sliding QR plate	Sliding QR plate with 1/4" + pin	Sliding QR plate with 1/4" + pin & 1/4" & 3/8" screws	QR plate with 1/4" & 3/8" screws	QR plate with 1/4" & 3/8" screws	QR plate with 1/4" & 3/8" screws
Sliding Range	60mm (±30mm)	60mm (±30mm)	60mm (±30mm)	70mm (±35mm)	70mm (±35mm)	100mm (±50mm)
Height Above Bowl	137mm	137mm	137mm	162mm	162mm	162mm
Mounting Base	75mm ball levelling	75mm ball levelling	75mm ball levelling	100mm ball levelling	100mm ball levelling	100mm ball levelling
Illuminated Controls	—	—	—	Bubble level and pan/tilt indicators	Bubble level and pan/tilt indicators	Bubble level and pan/tilt indicators
Temperature Range	-40°C to +65°C	-40°C to +65°C	-40°C to +65°C	-40°C to +65°C	-40°C to +65°C	-40°C to +65°C
Pan Handle	Fixed length	Fixed length	Fixed length	Fixed length	Telescopic	Telescopic

DS SERIES ALLOY TRIPODS

For small studio and location production, Miller's DS Series are professional lightweight tripods built for compact storage, maximum strength and optimum versatility. Miller's range of carbon and alloy, 75mm and 100mm, one and 2-stage tripods let you set up higher and lower in seconds, while offering optimum torsional rigidity for stable shooting in the studio or on location. Choice of above-ground or ground spreaders helps reduce set-up time and provides maximum stability on level or uneven surfaces.

440 DV Single-Stage Lightweight Tripod

Designed for small studio and location production, the 440 is a cost-effective solution for tight budgets. Made of durable black anodized alloy tubing, it has industry-standard 75mm bowl levelling which is attached to a ball-leveling mount that ensures bowl-to-leg fastening, resists loosening and eliminates joint instability. The 440 extends to a maximum height of 52.4", and closes down to 32.7". It has a single extension design and a toggle clamping system. It weighs 5.5 lbs., and supports up to 33 lbs.

440 DV Single-Stage Lightweight Tripod (Mfr # 440; B&H # MI440)**469.50**

420 DV Two-Stage Lightweight Tripod

Designed for rugged field use with extended two-stage height range, the 420 is made of durable black anodized alloy tubing, and features an above-ground spreader that provides maximum stability on uneven surfaces. It has industry-standard 75mm bowl levelling which is attached to a ball-leveling mount that ensures bowl-to-leg fastening, resists loosening and eliminates joint instability. The 420 extends to a maximum height of 61.4", has a minimum height of 15.4", and closes down to 27.2" for easy transport. It weighs 6.6 lbs., supports up to 55 lbs.

420 DV Two-Stage Lightweight Tripod (Mfr # 420; B&H # MI420)**824.95**

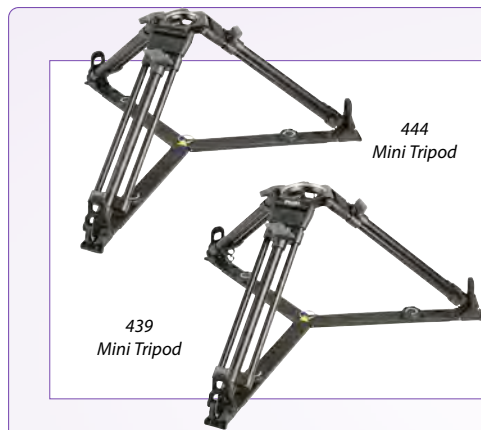

SPECIAL APPLICATION TRIPODS

444 Mini Tripod (Mfr # 444; B&H # MI444)

A single-stage tripod constructed with aluminum alloy, the 444 Mini Tripod offers 75mm bowl fixing, attached to a ball-leveling mount to ensure bowl-to-leg fastening, eliminating joint instability. Featuring toggle leg clamping system, this lightweight, compact tripod is quick and easy to set up and provides optimum torsional rigidity for stable shooting under any condition. Maximum height of 26", it supports up to 30 lb**399.95**

439 Mini Tripod (Mfr # 439; B&H # MI439)

Same as above with a 100mm bowl fixing.....**399.95**

455 Baby Legs Kit (Mfr # 455; B&H # MI455)

A 100mm two-stage alloy tripod with soft case and ground spreader. Constructed with aluminum alloy, the Baby tripod offers a 100mm bowl fixing attached to a ball-leveling mount to ensure bowl-to-leg fastening, eliminating joint instability. Featuring a toggle leg clamping system, this lightweight, compact tripod is quick and easy to set up and provides optimum torsional rigidity for stable shooting under any condition. The 455 has a maximum height of 20.5", a minimum height of 9.8", and folds down to 13.8" for easy transport. It has a payload capacity of 55 lb..**944.95**



SOLO ENG / SOLO DV TRIPODS

Designed for lightweight MiniDV and DVCAM camcorders, SOLO Series professional tripods feature leg angle locks that eliminate the need for a tripod spreader, and offer optimum torsional rigidity and long term durability. The 1505 SOLO ENG telescopic carbon fiber tripod was designed for video journalists on the run. It features a sleek three-stage telescoping design, and has an operating height range from 8.7" to an impressive 73". The two-stage SOLO DV tripods deliver a 12" - 63" height range, a silk-smooth fluid pan & tilt, plus an ultra-light, ultra-stable spreaderless tripod design.

1505 SOLO ENG Stellar ENG or EFP Support

The 1505 SOLO ENG has changed how cameraman view telescopic tripods by achieving incredibly high torsional rigidity in the lightest 100mm carbon fiber/magnesium design. Boasting an incredible 8" - 73" height range, this 3-stage ring-locking tripod collapses down to just 25 1/2". Designed for video journalists on the run, SOLO ENG is ultra-light and ultra-versatile, utilizing leg angle locking to eliminate the need for a spreader, and to reduce overall system weight and complexity.

1505 SOLO ENG Three-Stage Lightweight Tripod (Mfr # 1505; B&H # MI1505).....**944.95**

1630 SOLO DV Two-Stage Alloy Tripod

The 2-stage telescoping SOLO DV alloy tripod is designed for the single operator: quickly and securely setting up to 63"; packing down to a compact 27" for transport; and hitting a low 9". Selectable leg angle locks ensure rapid stabilisation at any height, while the 75mm diecast alloy bowl and fluid head bubble level offers quick levelling, optimum torsional rigidity and durability under extreme field conditions.

1630 SOLO DV Two-Stage Lightweight Tripod (Mfr # 1630; B&H # MI1630)**469.95**

1501 SOLO DV Two-Stage Carbon Tripod

The two-stage telescoping SOLO DV 1501 carbon fiber tripod is designed for a single operator. It sets up quickly and securely setting up to 63"; packing down to a compact 27" for transport; and hitting a low 9". Selectable leg angle locks ensure rapid stabilization at any height, while the 75mm diecast alloy bowl and fluid head bubble level offers quick levelling, optimum torsional rigidity and durability under extreme field conditions.

1501 SOLO DV Two-Stage Lightweight Tripod (Mfr # 1501; B&H # MI1501)**682.95**



DS SERIES AND SOLO SERIES TRIPOD SPECIFICATIONS

	440	420	444	439	455	1505	1630	1501
Weight	5.5 lbs.	6.6 lbs.	4 lbs.	4 lbs.	6.2 lbs.	6.8 lb.	6.4 lb.	5.5 lb.
Load Capacity	33 lb.	55 lbs.	33 lbs.	33 lbs.	55 lbs.	66 lb.	44.1 lb.	44.1 lb.
Bowl Diameter	75mm	75mm	75mm	100mm	100mm	100mm	75mm	75mm
Maximum Height	52.4"	61.4"	26.4"	26.4"	20.5"	73.6"	64"	63.5"
Minimum Height	24.4"	15.4"	11.8"	11.8"	9.8"	8.7"	9.2"	9.2"
Transport Length	32.7"	27.2"	18.9"	18.9"	13.8"	25.9"	27.6"	27.3"
Tube Type	Alloy	Black Alloy	Alloy	Alloy	Alloy	Carbon Fiber	Alloy	Carbon Fiber
Construction	Single-stage	2-stage	Single-stage	Single-stage	2-stage	3-stage	2-stage	2-stage

SPRINTER II TRIPODS

Sprinter II ENG tripods feature Miller's patented Sprint-Lok leg clamping system, which let you set-up in seconds. These easily accessible, high-speed locks let you independently adjust both stages of a two-stage tripod using one hand. Set-up speed is also increased by the rapid-action transport clips that flip on and off the tripod leg. A rugged mid-level spreader with an adjustable center hub lets you precisely and quickly fine-tune the height, while giving you the advantage of an extra 100mm of adjustment. A flexible inline carry handle ensures balanced carrying of the Sprinter II with any 100mm ENG head. The inline handle offers rigidity in the grip, with a flexible, inline Cordura attachment to the leg and lets the handle recede when the tripod is packed down. Sprinter II tripods are available as single- or two-stage tripods, with ultra-light carbon fiber or durable, anodized aluminum leg tubing.

- ◆ Easily accessible, high-speed dual action locks make it ergonomically easier to operate the co-located side action levers.
- ◆ Height-adjustable mid-level spreader for perfect height or width trimming.
- ◆ Quick leg height adjustment from one easy reach location.
- ◆ Unique inline carry handle comfortably carry the Sprinter II.
- ◆ Forever-flat rubber foot design provides stable support on any surface.

1589 Single-Stage Aluminum Tripod (Mfr # 1589; B&H # MI1589)

Single-stage tripod with integrated carry handle**737.50**

1584 Single-Stage Carbon Fiber Tripod (Mfr # 1584; B&H # MI1584)

Single-stage tripod with integrated carry handle**CALL**

1580 Two-Stage Aluminum Tripod (Mfr # 1580; B&H # MI1580)

2-stage tripod with dual Sprint-Loks and integrated carry handle**1082.95**

1576 Two-Stage Carbon Fiber Tripod (Mfr # 1576; B&H # MI1576)

2-stage tripod with dual Sprint-Loks and integrated carry handle**1523.50**

1593 Two-Stage XL Carbon Fiber Tripod (Mfr # 1593; B&H # MI1593)

2-stage extended-height tripod with integrated carry handle**CALL**

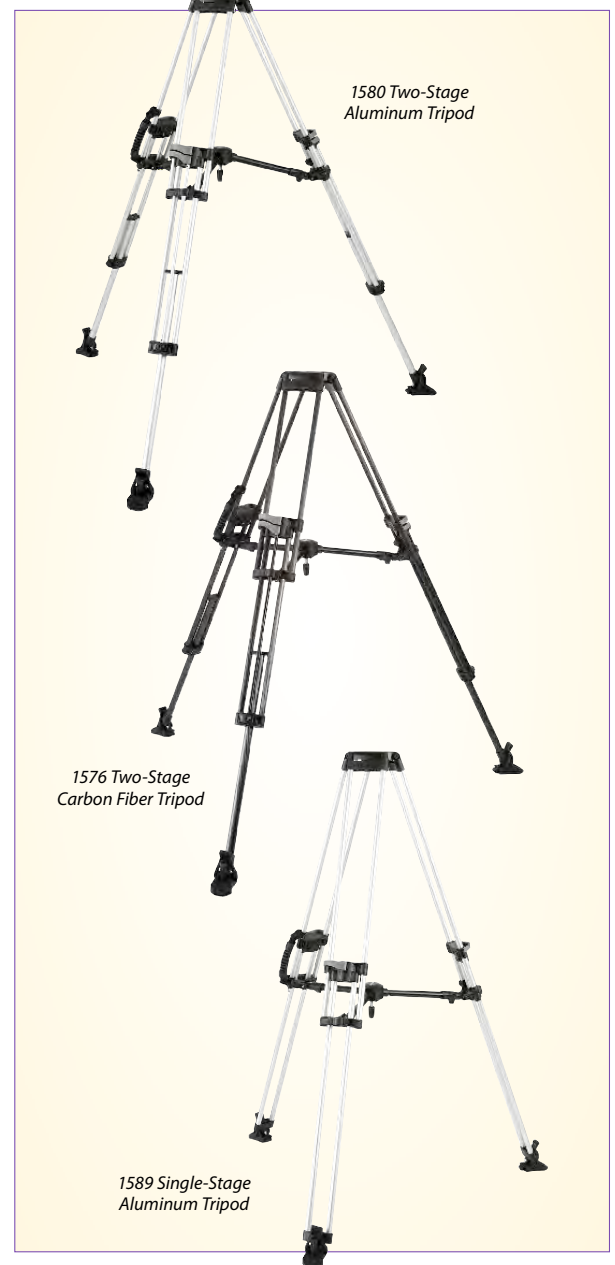

	1589	1580	1576	1584	1593
Tube Configuration	Single-Stage	Two-Stage	Two-Stage	Single-Stage	Two-Stage
Tube Material	Alloy	Alloy	Carbon Fiber	Alloy	Carbon Fiber
Maximum Load	100 lb.	100 lb.	100 lb.	100 lb.	100 lb.
Weight	6.8 lb.	7.7 lb.	6.3 lb.	5.5 lb.	7.5 lb.
Maximum Height	56.3"	60.4"	60.4"	57"	76"
Minimum Height	25"	17.3"	17.3"	26.1"	27"
Transport Length	33.1"	27.6"	27.6"	32.5"	34.6"

HD TRIPOD SERIES

Heavy-Duty ENG/EFP Tripods

HD tripods are built with the strength and torsional rigidity to take the full ENG/EFP workload — extreme climates and temperatures to -40° — and deliver rock-solid stability and optimum payload security when supporting studio camera configurations. They feature an easily detachable Mid-Level Spreader that lets you fine-tune your spreader position to match your application and location, an adjustable flip-lock for quick set-up and easy maintenance, and detachable rubber feet to provide stage support on any surface. Available as single- or two-stage tripods, 100 or 150mm bowl design, with high-strength 24mm cross-linked carbon fiber tubing or sturdy, hard anodized alloy tubing.

- ◆ Extended 2-stage height range for heavy-duty ENG; solid, single-stage support for EFP/sports.
- ◆ Available in high-strength 24mm cross-linked carbon fiber tubing or sturdy, hard-anodized alloy tubing.
- ◆ Split in-line carry handle for balanced hand-carrying (100mm only).
- ◆ Fully-adjustable Mid-Spreader with infinitely variable center hub adjustment allows rapid set-up on any level or uneven surface.
- ◆ Adjustable flip locks offer quick set-up and easy maintenance.

HD Heavy-Duty Carbon Fiber Tripod (Mfr # 925; B&H # MI925)
2-stage tripod with 100mm bowl and integrated carry handle**1879.95**

HD Heavy-Duty Alloy Tripod (Mfr # 931; B&H # MI931)
Single-stage with 100mm bowl and integrated carry handle.....**1229.95**

HD Heavy-Duty Studio Alloy Tripod (Mfr # 932; B&H # MI932)
Same as above, but 5.9" shorter for attachment to Studio Dolly...**1208.50**

HD Heavy-Duty Carbon Fiber Tripod (Mfr # 937; B&H # MI937)
2-stage tripod with 150mm bowl.....**1879.50**

HD Heavy-Duty Alloy Tripod (Mfr # 943; B&H # MI943)
Single-stage tripod with 150mm bowl.....**1352.95**

HD Heavy-Duty Studio Alloy Tripod (Mfr # 944; B&H # MI944)
Same as above, but 5.9" shorter for attachment to Studio Dolly...**1352.95**

HD Mini Heavy-Duty Alloy Tripod (Mfr # 935; B&H # MI935)
Mini single-stage tripod with 100mm bowl.....**1289.95**

HD Mini Heavy-Duty Alloy Tripod (Mfr # 945; B&H # MI945)
Mini single-stage tripod with 150mm bowl.....**1409.95**



	925	931	932	937	943	944	935	945
Tube Configuration	2-Stage	Single-Stage	Studio Single-Stage	2-Stage	Single-Stage	Studio Single-Stage	Mini Single-Stage	Mini Single-Stage
Tube Material	Carbon Fiber	Alloy	Alloy	Carbon Fiber	Alloy	Alloy	Alloy	Alloy
Maximum Load	210 lb.	210 lb.	210 lb.	210 lb.	210 lb.	210 lb.	210 lb.	210 lb.
Weight	9.9 lb.	11.5 lb.	10.4 lb.	10.1 lb.	11.8 lb.	10.6 lb.	8.8 lb.	9.3 lb.
Maximum Height	62.6"	62"	50"	63.6"	62.6"	50.4"	37.8"	38.2"
Minimum Height	18.9"	30.9"	23.2"	20.5"	31.5"	24"	13.8"	14.6"
Transport Length	29.5"	36.6"	30.8"	29.5"	37"	31.1"	25.4"	25.6"

PROJIB

Camera Jib Arm

Extend the creative scope of your film and video production. The Projib jib arm frees you from the limitations of single point-of-view shooting by adding a third dimension to your shot selection. For example, a pan and tilt head gives you horizontal and vertical motion from a fixed axis, while the Projib pans, tilts and diagonally tracks, to let you change your point-of-view. This is great for rehearsing the best position for 'pack shot' or 'table-top' shooting, while the dramatic tracking effects must be seen to be believed. Imagine tracking from ground level in a forest stream up to over 6½' in height in a single movement! Projib is lightweight, compact and portable, and is precision-engineered to meet the toughest physical demands of ENG/EFP and studio production. Designed to handle camera payloads up to 50 lb., Projib attaches easily to most conventional 100mm heads and tripods. This gives it flexibility for use as a cost-effective studio crane where on-shot elevation is required, or on location where set-up speed, weight and size are critical.

- ◆ Portable and lightweight, Projib is designed for single operator set-up. It weighs 25 lbs. packs down to 48" and supports 50 lbs.
- ◆ The silk-smooth diagonal tracking shots of Projib add a third dimension to traditional camera pan and tilt movements.
- ◆ A 6' swing, plus the versatile height range of tripod mounting, lets you shoot from ground level to over 6'.
- ◆ Available as a standalone unit or in system packages to suit lightweight field production or EFP/studio applications.

SPECIFICATIONS

Weight	25.1 lb.
Payload Capacity	55 lb.
Pan Drag	Adjustable friction system
Pan Rotation	360°
Pan Lock	Friction lock
Tilt Drag	Adjustable friction system
Tilt Lock	Friction lock
Counterbalance	1" center barbell weights
Dimensions	9.1 x 21.7 x 48" (WDL)
Height Range	78.7"
Head Attachment	100mm ball
Tripod Attachment	100mm ball
Levelling Indicators	2x Bubble levels
SKU #	Mfr # 711; B&H # MI711
Price	\$2749.95



Projib Camera Jib Arm shown on a tripod

PROJIB SYSTEMS

- Projib/Arrow 25 Single-Stage Alloy HD System** (Mfr # 1797; B&H # MI1797): Projib jib arm, Arrow 25 fluid head, heavy-duty single-stage alloy tripod, Sprinter/HD mid spreader, Sprinter/HD tripod rubber feet, pan handle with handle carrier, Projib soft case**7151.95**
- Projib/Arrow 40 2-Stage Carbon Fiber HD System** (Mfr # 1713; B&H # MI1713): Projib jib arm, Arrow 40 fluid head, heavy-duty 2-stage carbon fiber tripod, Sprinter/HD mid spreader, Sprinter/HD tripod rubber feet, pan handle with handle carrier, HD soft case, Projib soft case**8719.95**
- Projib/Arrow 55 Single-Stage HD Dolly System** (Mfr # 1749; B&H # MI1749): Projib jib arm, Arrow 55 fluid head, heavy-duty single-stage alloy Studio tripod, Sprinter/HD mid spreader, 2 pan handles with handle carriers, Projib soft case, Studio Tracker dolly**9988.50**

OPTIONAL ACCESSORIES



Studio Dolly (Mfr # 480; B&H # MI480): Combined with the Projib, the Studio Dolly is an indispensable creative tool. Smooth action castors, and a sturdy wheel lock ensure light, smooth dolly action. It features a reinforced center hub, a collapsible arm design, individual wheel brakes, and an integrated carry handle. Its 24.8" collapsed length enhances portability**787.95**

Studio Dolly (Mfr # 481; B&H # MI481): With height-adjustable cable guards**1003.95**

Studio Dolly (Mfr # 483; B&H # MI483): With independent track-wheel-locking and height-adjustable cable guards**1324.95**

Undermount Kit (Mfr # 715; B&H # MI715): Lets you track from ground level up to nearly 6' with absolute stability. Unlike other reverse mounts, it fits directly below the existing bowl to ensure the camera's center of gravity remains at its most stable point**Call**



Projib Soft Case (Mfr # 712; B&H # MI712): Ultra-light, ultra-tough protection for the Projib. Carry handles allow you to carry the Projib by hand or on your shoulder**367.50**



PEDESTALS

Pedestal 30 (Mfr # 730; B&H # MI730)

A gas lift pedestal for 30 lb. EFP and studio cameras, the Pedestal 30 delivers stability and column lift in a budget-conscious pedestal. It offers rapid, air-assisted column lift to all 10-30 lb. small studio cameras with LCD viewfinders and lightweight lens remote controls, and glides smoothly across any studio floor with its sturdy three-legged base and 4" castors with integrated brake locks.

- ◆ Gas assist lift column and lock.
- ◆ 4" castors with integrated brake locks.
- ◆ Flat base for universal head attachment.
- ◆ Suits small TV and corporate studios.

	Weight	Minimum Height Range	Height Range	Payload Capacity	Maximum Height Range	Mfr # / B&H # and Price
Pedestal 30	42 lb.	31.9"	32-46" in gas assist column	30.8 lb.	41.7"	730/MI730 \$1174.95



Pedestal 30 with Arrow 25 Fluid Head (Mfr # 733; B&H # MI733): The Arrow 25 adds 5 pan (plus '0') and 5 tilt (plus '0') drag positions to the Pedestal 30. This package gives you smooth moves in any direction, with safe, fast height re-positioning. Gliding an ENG or EFP camera with top mount viewfinder across a studio floor has never been smoother and more cost effective**4342.95**



Pedestal 60 (Mfr # 732; B&H # MI732)

The Pedestal 60 is a great solution for cameras where height repositioning is necessary. With a maximum payload capacity of 60 lb., this highly portable stand has the ability to support all EFP portable cameras with teleprompters. The gas assist column lift ensures rapid height repositioning, while the sturdy base and 4" castors offer smooth moving across all studio floors.

- ◆ Gas assist lift column with 60 lb. capacity.
- ◆ 4" castors with integrated brake locks.
- ◆ Flat base for universal head attachment.
- ◆ Column lock off and damping for safety.

	Weight	Minimum Height Range	Height Range	Payload Capacity	Maximum Height Range	Mfr # / B&H # and Price
Pedestal 60	42 lb.	31.9"	32-46" in gas assist column	60.1 lb.	41.7"	732/MI732 \$1149.50

Pedestal 60 Longer Column Option (MI732L): Allows the Pedestal 60 to extend from 38" - 54"**CALL**

Pedestal 60 with Arrow 40 Fluid Head (Mfr # 735; B&H # MI735)

The Arrow 40 adds 7 pan (plus '0') and 7 tilt (plus '0') drag positions, and four positions of counterbalance to the Pedestal 60. Gliding an ENG or EFP camera with a top mount viewfinder across the studio floor has never been smoother and more cost effective**4679.95**

Pedestal 60 with Arrow 55 Fluid Head (Mfr # 737; B&H # MI737)

The Arrow 55 adds 7-step fluid drag, 4-step spring counterbalance, and an oversized 100mm sliding quick-release camera plate. It offers the ideal column support for all EFP small studio cameras**5494.95**

Pedestal 60 with DS60 Fluid Head (Mfr # 738; B&H # MI738)

Designed to smoothly move 60 lb. payloads across the floor, this combination gives you stability and rapid column height adjustment for EFP cameras with teleprompters and CRT viewfinders. The DS60 Fluid Head adds dual telescopic handles with 4 pan/tilt positions and 4 counterbalance positions**6594.95**

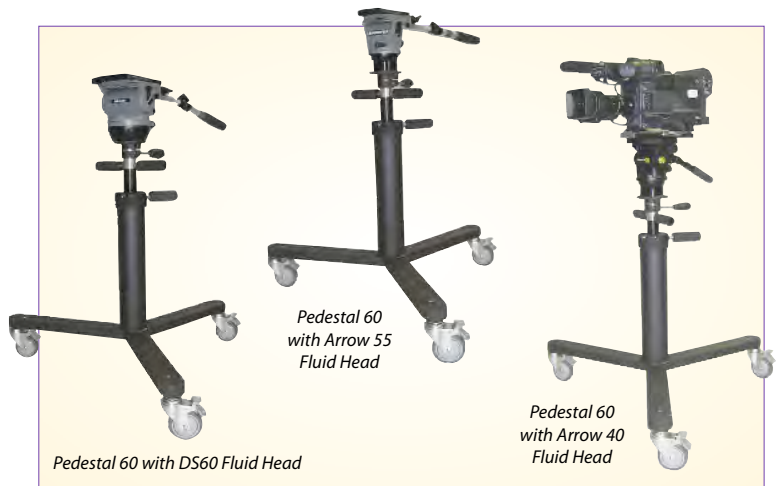

SPREADERS

On-Ground Spreader (Mfr # 411; B&H # MI411): For all lightweight, single-stage and 2-stage toggle tripods, the 411 features rapid set-up and pull down by keeping tripod legs at an equal or preset distance, telescopic arm extensions and integrated swivel foot pads.....**346.50**

On-Ground Spreader (Mfr # 470; B&H # MI470): For all Sprinter II single- and 2-stage tripods...**368.95**

Non-Telescopic Above-Ground Spreader (Mfr # 835; B&H # MI835) : For the DS Series 440 DV single-stage lightweight tripod. The Above-Ground spreader has the ability to quickly set up on uneven surfaces like steps and rocks, and offers rapid set-up and pull-down by keeping tripod legs at an equal or preset distance. It attaches to the center bracket of a tripod.....**158.50**

Adjustable Above-Ground Spreader (Mfr # 510; B&H # MI510): For the DS Series 440 DV single-stage lightweight tripod. Its arms extend to 20.7" to allow extension of a tripod leg without detaching the spreader. It folds down within the tripod legs**314.95**

Adjustable Above-Ground Spreader (Mfr # 512; B&H # MI512): Same as above, for the DS Series 420 DV two-stage lightweight tripod**314.95**

Adjustable Mid-Level Spreader (Mfr # 990; B&H # MI990): For all Sprinter II and HD tripods. It attaches directly to the center bracket of the tripod with a quick release latch, and allows rapid set-up and pull down by keeping the tripod legs at an equal or preset distance relative to each other. It features telescopic arm extensions, an infinitely-adjustable center hub, and a fast spring clip spreader attach/detach.....**439.95**

Adjustable Mid-Level Spreader with Attachment Brackets (Mfr # 991; B&H # MI991): Same as above, but with attachment brackets. For all Sprinter II and HD tripod.....**474.95**

ENG/EFP Tripod Rubber Feet (Mfr # 550; B&H # MI550): Suitable for all lightweight, single-stage and two-stage tripods with above-ground spreaders (ground spreaders have integrated foot pads). Rubber feet provide stable support for tripods on any surface. Set of 3**114.50**

Sprinter/HD Tripod Rubber Feet (Mfr # 475; B&H # MI475): Suitable for all Sprinter II and HD tripods with an above ground spreader (ground spreaders have integrated foot pads). Rubber feet provide stable support for tripods on any surface. Set of 3**114.50**



SOFT CASES

Miller compact and comfortable soft cases feature rigid sidewalls sandwiched between high-density foam padding, a patented head-end cradle that protects the fluid head from heavy bumps during flight and vehicle transport, heavy-duty zippers on the bag and all packets, padded carry straps and weatherproof Cordura construction.



	1518	872	876	870	874	974
Weight	1.4 lb.	6.6 lb.	3.7 lb.	7.7 lb.	4.2 lb.	9.5 lb.
External Dimensions (LWH)	33.5 x 6.15 x 6.5"	36.6 x 7.5 x 8.3"	36.6 x 8.3 x 8.3"	42.5 x 7.5 x 8.3"	42.3 x 8.3 x 8.3"	38.6 x 10.2 x 10.2"
Accommodates	DV Solo Tripods	Arrow 2-stage tripods ¹	2-stage tripods ²	Arrow 1-stage tripods ¹	DS & 1-stage tripods ¹	Arrow HD tripods
SKU / Price	MI1518 \$63.50	MI872 \$369.95	MI876 \$244.95	MI870 \$368.50	MI874 \$244.95	MI974 \$379.95

1. Except HD tripod 2. Except Arrow and systems with HD tripod

DOLLIES

394 Lightweight Aluminum Dolly (Mfr # 394; B&H # MI394): The SOLO Dolly boasts a 28.7" minimum width dimension for safe maneuverability through standard doorways, while a collapsed length of only 21.7" and aluminum construction weighing only 5.5 lb. enhances portability. The ergonomically designed carry handle is molded into the dolly's reinforced die-cast center bracket for optimum carriage strength. TPR rubber wheels offer ultra-smooth, fluid-style rolling action, and dual-lock braking on each wheel and castor. For Solo DV and SOLO ENG tripods**442.95**

391 Lightweight Aluminum Dolly (Mfr # 391; B&H # MI391): Built for 75mm DS tripods and lightweight payloads, the 391 offers cost-effective, professionally smooth dolly action. It features 2.95" wheels, independent wheel locks, and integrated rubber tripod stirrups. The 391 folds down for easy carriage with carry handle. A secure saddle mount locks the tripod firmly**559.95**

390 Medium Duty Aluminum Dolly (Mfr # 390; B&H # MI390): A cost-effective dolly for use with Miller 100mm toggle-style DS tripods, as used with the lightweight ENG/Studio system. It features 125mm wheels for light, smooth dolly action, independent wheel locks, integrated rubber tripod stirrups, and a secure saddle mount that locks the tripod firmly. The 390 folds down and is easily carried with the carry handle**766.95**

480 Studio Dolly (Mfr # 480; B&H # MI480): For Sprinter/HD tripods. The 480 has a reinforced center hub with collapsible box tubing arms. Smooth action castors ensure sturdy, smooth support under all Miller ENG and HD tripods. It features sturdy Tente roller castors, individual wheel brakes, and an integrated carry handle **787.95**

481 Studio Dolly with Cable Guards (Mfr # 481; B&H # MI481): For Sprinter/HD tripods. The 481 Studio Dolly boasts height-adjustable cable guards for smoothing out studio floor litter, plus a reinforced center hub with collapsible box tubing arms, smooth action castors, and a sturdy wheel lock. The collapsible arm design lets the 481 glide through doorways unhindered.....**1003.95**

483 Studio Dolly with Cable Guards and Tracking Locks (Mfr # 483; B&H # MI483): For Sprinter/HD tripods. The 483 Studio Dolly combines height-adjustable cable guards with independantly controllable wheel tracking. The tracking system lets you lock and glide the 483 dolly in a straight line across the studio floor, and also lets you rotate your dolly in a circular motion by engaging a single wheel. It has a reinforced center hub with collapsible box tubing arms, smooth action castors, and a solid individual braking system**1324.95**

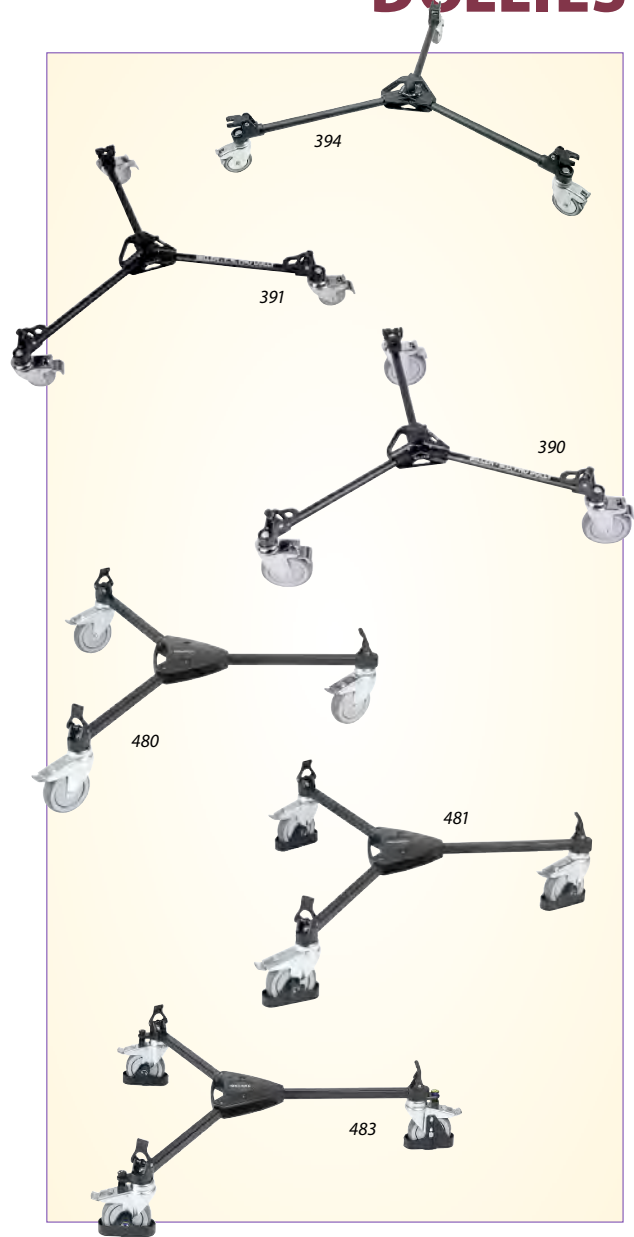

SHOULDER STRAPS

554 Shoulder Strap (Mfr # 554; B&H # MI554): A 2" wide weatherproof Cordura/Nylon shoulder strap with ergonomic 'padded cell' air-bubble shoulder support. A safety spring latch attaches to all 75mm and 100mm tripods. 31.5" minimum length; 43.3" maximum length.....**118.50**

1520 Shoulder Strap (Mfr # 1520; B&H # MI1520): A 1.5" wide weatherproof Cordura/Nylon shoulder strap with ergonomic 'padded cell' air-bubble shoulder support for Solo DV tripods.....**43.95**

1590 Solo Protective Leg Covers (Mfr # 1590; B&H # MI1590): Additional protection for Solo legs. Available as a pack of three covers. Will cover leg with or without standard neoprene grip.....**CALL**

ACCESSORIES

CAMERA PLATES
AND SCREWS

493: 1/4" -20 & Location Pin Adapter Carriage: Industry-standard 1/4" and pin fits all standard Miller camera plates. Direct-to-camera base for Mini DV camcorders. (Mfr # 493; B&H # MI493)**44.95**

490: Quick-Release Sliding Camera Plate: Quick-release sliding camera plate with 60mm travel. For DS-5 and DS-10 fluid heads. Includes the 1/4" -20 and Location Pin Adapter Carriage (493). (Mfr # 490; B&H # MI490)**84.50**

489: DS-20 Camera Plate: Quick-release sliding camera plate with 60mm travel. For DS-20 fluid head. Includes the 1/4" -20 and Location Pin Adapter Carriage (493), plus 1/4" -20 (036) and 3/8" -16 (037) screws. (Mfr # 489; B&H # MI489)**128.95**

860: Arrow Camera Plate: Euro-style quick-release sliding camera plate with 70mm travel for all Arrow fluid heads. Includes industry-standard 1/4" -20 (036) and 3/8" -16 (037) screws for attachment. (Mfr # 860; B&H # MI860)**134.95**

1060: Arrow Camera Plate: Large Euro-style quick-release sliding camera plate with 100mm travel for DS-60 fluid head. Includes two 3/8" -16 (037) screws for attachment. (Mfr # 1060; B&H # MI1060)**149.95**

036: 1/4" -20 (Small) Screw: Small screw to attach camera to quick-release camera plates. (Mfr # 036; B&H # MI036)**12.50**

037: 3/8" -16 (Large) Screw: Large threaded screw to attach camera to quick-release camera plates. (Mfr # 037; B&H # MI037)**12.50**

SPECIAL MOUNTS

465: 75mm Hi Hat: Bolts to any flat surface; can be permanently mounted. Suits 75mm ball levelling heads. 44 lb. payload capacity. (Mfr # 465; B&H # MI465)**319.95**

466: 100mm Hi Hat: Accommodates 100mm ball levelling heads. Supports a payload of up to 55 lbs. (Mfr # 466; B&H # MI466)**314.95**

467: 150mm Hi Hat: Accommodates 150mm ball levelling heads. Supports a payload of up to 88 lbs. (Mfr # 467; B&H # MI467)**466.95**



ADAPTERS

378: 100 to 75mm Tripod Bowl Adapter: Lets you mount 75mm ball levelling heads onto 100mm ball tripods, Hi-hats and Pro Jib. Accepts all 75mm heads: DS5, DS10 and DS20. (Mfr # 378; B&H # MI378)**158.50**

362: 150mm Bowl to Flat Base Adapter: Adapts a ball levelling head to a flat base tripod mounts. Die-cast alloy construction guarantees durability and strength. (Mfr # 362; B&H # MI362)**Call**

360: 100mm Bowl to Flat Base Adapter: Adapts ball levelling head to flat base tripod mounts. Die-cast alloy construction guarantees durability and strength For all Arrow heads. (Mfr # 360; B&H # MI360)**Call**

361: 75mm Bowl to Flat Base Adapter: Adapts ball levelling head to flat base tripod mounts. Die-cast alloy construction guarantees durability and strength. Accepts all 75mm heads: DS5, DS10 and DS20. (Mfr # 361; B&H # MI361)**148.95**

PAN HANDLES

679: 16mm Fixed-Length Pan Handle: With black handle carrier for Arrow 25 fluid head. Durable black anodized aluminium tubing. (Mfr # 679; B&H # MI679)**174.50**

680: 16mm Fixed-Length Pan Handle: With grey handle carrier for DS-5, DS-10 and DS-20 fluid heads. Durable black anodized aluminium tubing. (Mfr # 680; B&H # MI680)**174.50**

688: 16mm Fixed-Length Pan Handle: For DS-5, DS-10 and DS-20 heads. With positive grip rubber handle. (Mfr # 688; B&H # MI688) ...**CALL**

692: 16mm Telescopic Pan Handle: Extends from 15.4" to 24". For Arrow 40 and 55 heads. (Mfr # 692; B&H # MI692)**CALL**

694: 16mm Telescopic Pan Handle: Extends from 15.4" to 24". With black handle carrier for Arrow 40 and Arrow 55 fluid heads. Durable black anodized aluminium tubing. (Mfr # 694; B&H # MI694)**223.50**

684: 16mm Telescopic Pan Handle: Extends from 15.4" to 24". With grey handle carrier for DS60 fluid head. Durable black anodized aluminium tubing. (Mfr # 684; B&H # MI684)**223.50**

FLUID HEADS

Ultimate 1030HD • Ultimate 1030HDS



Featuring OConnor's stepless, ultra-smooth pan & tilt fluid drag specifically enhanced for HD applications, the Ultimate 1030HD provides ultimate control and stability for HD shooting up to 39 lbs. A mid-sized head based on the Ultimate 2575C fluid head—the standard for 35mm film cameras, the 1030HD features OConnor's patented sinusoidal counterbalance system for true, accurate balance at any point in the tilt range. Ultra-smooth pan and tilt true-fluid drag may be adjusted down to a zero setting, necessary for stable, confident "whip" movements. Positive tilt-locking pin positively locks head for fast and safe camera changes. Interchangeable platforms for 100mm, 150mm, Mitchell, and Sachtler/Vinten.

The 1030HDS is the "Studio" Version of the 1030HD. With a ±60° tilt range and an increased capacity load of 41 lbs. the 1030HDS is ideal for studio applications.

- Ultimate 1030HD Fluid Head** (Mfr # 1030-173; B&H # OC1030HD)**3889.95**
- Ultimate 1030HDS (Studio) Fluid Head** (Mfr # 1030-333; B&H # OC1030HDS)**4163.50**

Ultimate 1030HD Fluid Head Package (Mfr # 1030HD-PKG; B&H # OC1030HDPKG): Includes Ultimate 1030HD fluid head, mini European quick release with camera mounting plate, 14.5" pan arm, 10" pan arm extension, 100mm ball base, 100mm tiedown.....**4999.95**

Ultimate 1030HDS (Studio) Fluid Head Package (Mfr # 1030HDS-PKG; B&H # OC1030HDSPKG): Includes Ultimate 1030HDS fluid head, mini European quick release with camera mounting plate, 14.5" pan arm, 10" pan arm extension, 100mm ball base, 100mm tiedown**5134.95**

Options for the Ultimate 1030HD and 1030HDS

- Mini European Quick Release** (Mfr # 08430 • B&H # OCQRSM1030)**542.50**
- Large European Quick Release:** With 120mm camera mounting plate and screws (Mfr # 1030-268 • B&H # OCQRSL1030).....**654.95**
- 150mm Ball Base Adapter:** Allows mounting on 150mm bowl tripods. Requires 150mm ball tiedown (Mfr # 08414 • B&H # OCB150)**339.95**
- 150mm Ball Tiedown:** For attaching the Ultimate 1030HD/HDS on 150mm bowl tripods. (Mfr # 08417 • B&H # OC150TD)**113.95**
- Mitchell base Adapter:** Allows mounting on Mitchell base tripods. Requires Mitchell base tiedown (Mfr # 08281 • B&H # OCBM).....**338.50**
- Mitchell Tiedown:** Five-lobed retaining nut used with gear and fluid heads with Mitchell threaded post mounts.
- Eyepiece Leveler Bracket:** For use when using long, heavy eyepiece extensions. (Mfr # 08359 • B&H # OCEPLB1030).....**348.50**
- 14.5" Pan Handle with 34° bend (3/4" diameter)** (Mfr # 1030-145 • B&H # OCH145DV)**143.50**
- 10" Extension for above** (Mfr # 1030-152 • B&H # OCHE10).....**147.50**
- 12" Pan Handle with 30° bend (18mm diameter)** (Mfr # 1030-246 • B&H # OCH121030)**196.50**
- 11.5" Extension for above** (Mfr # 2575-135 • B&H # OCHE115).....**217.95**
- 7" Straight Base Handle (18mm diameter)** (Mfr # 08390 • B&H # OCHSBDV)**156.50**
- Randall Handle Extension:** For 18mm diameter handles (Mfr # 08388 • B&H # OCHER14).....**359.95**

Ultimate 2060HD

Specifically engineered for supporting HD cameras, the Ultimate 2060HD features OConnor's peerless sinusoidal counterbalance system, but with the addition of greatly enhanced pan and tilt dampening. Higher resolution means more critical attention to details such as sets, lighting, makeup, and the actual conveyance of the camera- herein lies the need for an especially smooth fluid head, such as the ULTIMATE 2060HD. Capable of supporting camera payloads up to 83 lbs., it features dual adjustable pan arms, an interchangeable top stage, an interchangeable base, and threaded connection points for finder extensions and an assistant's box. Platform locking pin holds the platform horizontal during camera changes. It also carries a 5-year warranty for parts and labor

- Ultimate 2060HD Fluid Head:** (Mfr # 2060-163; B&H # OC2060HDFH)**7316.50**
- Ultimate 2060HD Fluid Head Package** (Mfr # 2060HD-PKG; B&H # OC2060HDPKG)
Includes Ultimate 2060HD fluid head, Euro-style quick release with 120mm mounting plate and screws, 12" pan bar, 11.5" pan arm extension, 150mm ball base, 150mm tiedown.....**8946.95**



FLUID HEADS



Ultimate 2575C

The Ultimate 2575C is the pinnacle of true fluid head design. With a payload capacity of up to 133 lbs. it is just the ideal choice for large studio or EFP camera payloads requiring precision handling. The head features continuously variable dual-axis sinusoidal counterbalance for finger-tip camera control throughout the 180° tilt range, and continuously variable fluid drag to suit any shooting style. A collapsible counterbalance crank handle and numerical readout make repeatable counterbalance easy. The top stage slides to accommodate uneven payloads due to heavy lenses or magazines, and has a 120mm euro quick-release for rapid setups and take-downs. Illuminated bubble level facilitates efficient, precise setups in any working conditions

Ultimate 2575C Fluid Head (Mfr # 2575-253; B&H # OC2575C)**9399.95**

Ultimate 2575C Fluid Head Package (Mfr # 2575C-PKG • B&H # OC2575CPKG): Includes Ultimate 2575C fluid head, large Euro quick-release, 18mm pan arm, Mitchell base, Mitchell tiedown**11,237.50**

120EX Fluid Head

Based on new sinusoidal EX-technology, the patented 120EX fluid head features a new kind of stepless counterbalance system as well as a new ultra-smooth pan & tilt fluid drag designed for film style shooting. Now, with the use of EX-technology OConnor can offer the features it has become famous for while offering an additional benefit— extended capacity. With a new counterbalance mechanism at the heart of the EX-technology, the 120EX can be boosted into EX-mode to achieve a whole new realm of counterbalance.

The 120EX fluid head has a given payload of 30-120 lbs. for the ±90° tilt range. With traditional counterbalance mechanisms any payload heavier than this maximum weight can't be balanced. The 120EX can go far beyond that by slowly limiting tilt range as the payload is increased. The maximum payload is reached at a tilt range of ±60°. That means, in EX mode the 120EX can counterbalance up to incredible 240 lbs. at a tilt range of ±60°; all based on a 8" center of gravity.

120EX Standard Assembly: Includes 120EX Head, Mitchell base and tiedown, european handle and extension, geared platform plate (Mfr# C12250001 • B&H# OC120EXSA).....**11,478.50**



Options for Ultimate 2060, 2575C and the 120EX

Standard OConnor Plate (Mfr # 08283 • B&H # OCQRP2575)**407.95**

Euro Style Quick Release for 2060HD, 2575C: With 120mm camera mounting plate and screws. (Mfr # 2575-120 • B&H # OCQRSL2575)**1056.50**

Panavision Dovetail Plate (Mfr # 2575-110 • B&H # OCPPD2575).....**606.95**

Arriflex Dovetail Slide Plate
(Mfr # 2575-210 • B&H # OCPAD2575)**612.50**

Arriflex 24" Platform Plate Assembly
(Mfr # C2575-240 • B&H # OCPPA)**1004.50**

Straight Base Pan Handle (18mm diameter)
(Mfr # 08389 • B&H # OCHS2060)**156.50**

Randall Handle Extension: For 18mm diameter handles
(Mfr# 08388 • B&H# OCHER14)**359.95**

Front End Handle (for 2575 & 120EX Only)
Designed to fit into the front rosette. This provides the operator with the ability to maneuver and position the camera safely, accurately, and comfortably. (Mfr# 08409 • B&H# OCFEH2575)**289.95**

16.5" Pan Handle with 30° Bend (1" diameter)
(Mfr # 2575-107 • B&H # OCH1652575)**217.95**

12" Extension for Above (Mfr# 2575-105 • B&H# OCHE12)**238.95**

Eyepiece Leveler Bracket (Mfr # 08359 • B&H # OCEPLB1030)
For use when using long, heavy eyepiece extensions.....**348.50**

Assistant's Front Box (Mfr # MFB100 • B&H # OCAFB)
Provides storage for tools and accessories when using any of the fluid heads.....**288.50**

Assistant's Front Box Mount (Mfr # 08308 • B&H # OCAFBM)
Provides a mounting position for the MFB100 Assistant's Front Box when using any of the OConnor fluid heads**292.95**



TRIPODS

25L Two-Stage Carbon Fiber Tripod with Spreader

The 25L is an ultra lightweight two-stage tripod and has an incredible range of 15" to 66" while maintaining an extremely stable platform. A perfect choice for EFP, the carbon fiber 25L incorporates recessed horizontal leg lock levers that are easily accessible for safe and secure height adjustment.

35L Carbon Fiber Tripod with Spreader (100mm)

This lightweight, rugged, quick deployment tripod features instant set-up on most terrain. This is achieved by having a ring, located under the tripod top casting, which releases all three legs simultaneously. Each leg can also be independently adjusted. The ultimate ENG tripod, the 35L also has a two-position adjustable rigid spreader that adds even greater height range.

For fast breaking news, sports and production, this tripod goes from 26" to 62" with a single adjustment. Just press, lift, release, the three legs will lock automatically and you're ready to go.

Cine HD and Cine HD Baby Tripods

Constructed from time-proven aluminum alloy metallurgy, there will be no surprises, and they require no special accommodations. The single-stage design and die-cast spider ensure maximum rigidity for head and camera loads up to 309 lbs. and the rotary stage clamps provide tool-free temperature-independent leg fixing. Otherwise the same, the Cine HD Baby is a short leg tube "baby" version for extra low angles.

- ◆ Single-stage design for maximum rigidity
- ◆ Die-cast alloy spider/receiver top stage
- ◆ Rotary stage clamps are temperature-independent
- ◆ Dual leg spikes for high and low angles

25L Carbon Fiber 2-Stage Tripod Legs (100mm Bowl) with Mid-Level Spreader
 (Mfr# 25L-103 • B&H# OC25L) **1964.95**

35L Carbon Fiber 1-Stage Tripod Legs (100mm Bowl) with Two-Position Spreader - Supports 60 lbs.
 (Mfr# 35L-003 • B&H# OC35L) **1817.50**

Cine HD Single-Stage Aluminum Alloy Tripod (Mitchell) (Mfr# C1221-0001 • B&H# OCCHDTM) **1864.50**

Cine HD 1-Stage Aluminum Alloy Baby Tripod (Mitchell) (Mfr# C1221-0002 • B&H# OCCHDBTM) **1726.50**



	25L	35L	Cine HD	Cine HD Baby
Material	Carbon Fiber	Carbon Fiber	Aluminum	Aluminum
Load Capacity	60 lbs.	60 lbs.	309 lbs.	309 lbs.
Weight	7.3 lbs.	8.1 lbs.	29.3 lbs.	18.5 lbs.
Maximum Height	66"	62"	69.2"	34.6"
Minimum Height	14.75"	26"	33.6"	4"
Ball Diameter	100mm	100mm	Mitchell or 150mm	Mitchell or 150mm
Collapsed Length	28"	36.5"	40.4"	23.6"
Collapsed Width	7"	7"	11.1"	11.1"

FLUID HEADS

Functional and Easy to Operate

Sachtler's fluid heads offer 100 percent reliability. The patented damping system excels even when you and your equipment are challenged by the most adverse shooting conditions imaginable. Extreme temperatures have absolutely no effect on Sachtler's fluid heads. They provide frictionless operation, are free of hydraulic oil and are completely enclosed in their own capsule against any external influence. A special feature of the heads is their ease of operation. Instead of time-consuming adjustment and re-adjustment in search of the perfect balance, Sachtler's fluid heads offer finely tuned counterbalance for optimized settings.

Stability

A key reason why Sachtler fluid heads function so reliably is their stability. All components cooperate in a friction-free environment, a

key consideration for users who want equipment that functions tirelessly for years to come. In addition the modern, lightweight materials used helps limit the stress that unnecessary weight can have on your equipment, especially during long shoots.

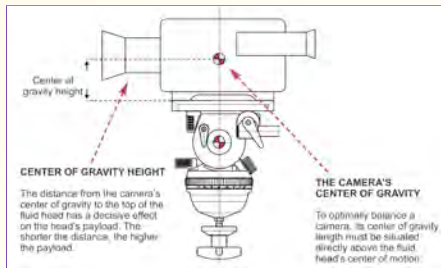

The Secret behind the Payload

The center of gravity height (C.O.G.) of the camera set up on a fluid head is decisive in determining the head's payload. The C.O.G. describes the distance between the camera or camcorder's center of gravity and the top edge of the fluid head being used. The shorter the distance, the greater the maximum camera weight.

Workmanship

The meticulous quality of these products is due in part to Sachtler's close working relationship with film and television professionals. The regular feedback sent in from the field provides their engineers with the constant incentive to redesign even their most proven products. The result is solid, innovative and extremely reliable products with a longer than usual life span.

Systems designed to meet your needs

A fluid head can only be fully effective with the right pedestal or tripod. Sachtler also offers a wide range of camera support system packages that are designed to meet your demands. The systems let operators choose between differently configured tripods with e.g. spreaders or mid-level spreaders. In most cases, a padded bag or cover is included in the package. Users can also customize and extend their own systems with optional accessories, such as additional pan bars or adapters.

The film maker's partner

Sachtler is a sustaining member of many different organizations and institutions that represent and unite camera operators, film makers and manufacturers of film and broadcast technology. Membership in the German Society of Cinematographers (bvj), has put them into direct contact with all well-known cameramen and camerawomen in the German speaking world. And their international service and dealer network puts them into direct contact with camera operators all over the globe. Sachtler also exchanges experiences with many of the other manufacturers of broadcast equipment in the International Association of Broadcast Manufacturers (IABM), where questions concerning standardization, current technical trends and developments are discussed.

Recommended for High Definition (HD)

All Sachtler fluid heads are suitable for use with HD cameras. Some heads, such as the Cine 75 HD or the Horizon, are particularly user friendly for classical film camera operators, who will find all the operating controls in their usual place. Of course, those who shoot with cinematography camcorders (e.g. Varicam) also want to take advantage of features such as a viewfinder extension or front box. Excellent solutions for users of small and lightweight HDV camcorders are also available, such as the SpeedBalance head DV 6 SB.

Service

Sachtler's worldwide distribution provides a widespread service net.

All authorized dealers can carry out repairs or exchange parts. And in acute situations, Sachtler even provides replacement

tripods or heads. Additionally, you can download operation manuals for almost all Sachtler products directly from their website. They provide highly detailed technical information, lists of parts and explosion drawings.



From Featherweight to Heavyweight

Sachtler offers the ideal tripod for every camera and camcorder. Whether your equipment weighs just a few hundred grams, like the digital (Mini) DV camcorder commonly used in day-to-day news gathering, or over 110 lb., like many film and studio cameras loaded with multiple accessories and high-performance optical systems, we have the right tripod for you.

Guarantee

Every Sachtler product comes complete with a comprehensive guarantee. Thorough quality testing both during and on completion of production ensure problem-free, reliable operation over a long life span.

SACHTLER

75MM FLUID HEADS



FSB 2

Sensitive, fast and robust – the FSB 2 is a small head that delivers awesome shots. Perfectly designed for Mini DV and small HDV cameras, the FSB 2 can handle payloads ranging from 0 to 4.4 lbs. It offers counterbalance settings of 1 and 0, and has three horizontal and three vertical grades of drag plus 0. No compromises have been made with regard to the damping, which is based on the same construction principles as Sachtler’s “large” heads.

FSB 2 Fluid Head (Mfr # 0207)CALL

FSB 6 • FSB 6T

Bigger, but equally sensitive, fast and robust, the FSB 6 handles payloads ranging from 2.2 to 13.2 lbs., and is ideal for Mini DV and HDV cameras. It is also the only head in its class to feature Sachtler’s Snap & Go sideload mechanism which boasts an exceptionally large 4.7” sliding range and 10-step counterbalance, which ensures extremely fine and fast balancing. Alternatively, the head is also available with the classic Touch & Go camera plate (FSB 6T). The FSB 6 also has three horizontal and three vertical grades of drag plus 0. For added convenience, a self-illuminated Touch Bubble makes balancing in poor light conditions even easier. No compromises have been made with regard to the damping, which is based on the same construction principles as Sachtler’s “large” heads.



FSB 6 Fluid Head (Mfr # 0407; B&H # SAFSB6)1249.95

FSB 6T Fluid Head (Mfr # 0405; B&H # SAFSB6T)1249.95

Model	Payload	Weight	Tilt Range	Counterbalance	Drag	Bowl Diameter
FSB 2	4.4 lbs.	4.1 lbs.	+90/-70°	2 Steps	3+0	75mm
FSB 6	13.2 lbs.	4.4 lbs.	+90/-70°	10 Steps	3+0	75mm
FSB 6T	13.2 lbs.	4.1 lbs.	+90/-70°	10 Steps	3+0	75mm

FSB Cell

Combine the FSB 2 or FSB 6 with Sachtler’s revolutionary FSB Cell, and the fluid heads become real powerhouses. This 10.5 AH lithium rechargeable camera battery, which fits directly below the camera, provides 8 hours of shooting time, ensuring maximal flexibility on the set. The ultra-high performance FSB Cell is a 7.2 volt lithium-ion battery that loads directly beneath Mini DV and HDV cameras. Shaped like a camera plate, the battery’s underside fastens perfectly onto the fluid head to ensure secure locking. The battery’s 1.4 lb. weight is positioned directly over the fluid head. This optimizes camera control, by acting neutrally when balancing the camera, as well as adding stability. The result is uniform, smooth camera pans. When teamed with the FSB CELL, the sliding range of the camera set-up is extended even further to 8.6” (225mm) for optimal balance.



- ◆ The FSB Cell’s high-performance lithium-ion lets you operate MiniDV and HDV camcorders for over 8 hours, greatly increasing independence on the shoot.
- ◆ As with other Sachtler products, extremely fast changeover between tripod and shoulder further adds to on-set flexibility - the camera is quickly removed together with the battery and just as easily replaced.

- ◆ It incorporates the Sachtler Snap & Go camera attachment system into its top and bottom surfaces for sure and easy connection between the camcorder and Sachtler fluid head. Thus the operator can quickly convert from tripod mount to hand-held use
- ◆ The FSB Cell can be used with Sony, Canon and Panasonic cameras with an optional adapter cable connecting battery and camera.

FSB Cell (Mfr # 0781 • B&H # SAFSBC)
7.2v 10.5AH Camcorder Battery.....**219.95**

Battery Charger (Mfr # 0782 • B&H # SACFSBB)
For FSB Cell.....**169.95**

FSB Cell Cable Adapter (Mfr # 0785 • B&H # SACAFSBS1)
For Sony DSR-PD170, DCR-VX2100, HDR-FX1.....**78.95**

FSB Cell Cable Adapter (Mfr # 0788 • B&H # SACAFSBBP)
For Panasonic AG-HVX200, AG-DVX100A/B.....**78.95**

FSB Cell Cable Adapter (Mfr # 0786 • B&H # SACAFSBS2)
For the Sony HVR-Z1U**78.95**

FSB Cell Cable Adapter (Mfr # 0787 • B&H # SACAFSBBC)
For Canon XH-1, XL-1/1s/2, GL-1/GL-2**78.95**

75MM & 100MM FLUID HEADS



DV 6 SB

Compact digital cameras have created a new era in electronic reporting, documentaries and industrial films. It's easy to see why – they are light, fast and highly versatile. To complement these cameras is the DV 6 SB fluid head, the professional choice. The DV 6 SB comes with 5-step fluid damping (5 horizontal and 5 vertical grades of drag) and a 10-step counterbalance system from 2 to 20 lbs. This enables the ambitious videographer to not only use different camera loads, but also to choose between different drag steps. For added convenience, equipped with self-illuminated Touch Bubble that make balancing in poor light conditions even easier.

DV 6 SB Fluid Head (Mfr # 0605; B&H # SADV6SB)**1599.95**

DV 8 SB

Ideal for documentary, industrial videos, and more, the DV 8 SB steps-up with 12-step counterbalance system and payload capacity from 2 to 26 lbs. Interchangeable pan arm rosettes allow a second pan bar, standard or telescopic, to be added if ever you need it. Weighs just 2 oz. more than the DV 6 SB. Like the DV 6 SB, it includes 2.4" sliding balance plate and Touch & Go quick-release, and 5-step fluid damping (5 horizontal and 5 vertical grades of drag). For added convenience, equipped with self-illuminated Touch Bubble that make balancing in poor light conditions even easier.

DV 8 SB Fluid Head (Mfr # 0805; B&H # SADV8SB75)**2198.95**



DV 8 / 100 SB

Ideal for documentary and industrial videos, and much more, the DV 8/100 SB is identical to the the DV 8 SB except it's used with 100mm bowl. Features 12-step counterbalance system and payload capacity from 2 to 26 lbs. Includes illuminated bubble level, 2.4" (60mm) sliding balance plate and Touch & Go quick release.

DV 8 / 100 SB Fluid Head (Mfr # 0806; B&H # SADV8SB100)**2306.95**

DV 12 SB

With a load capacity of up to 30 lbs., the DV-12 SB is the choice for the professional videographer utilizing heavy camcorders who demands the smoothest pans and tilts in addition to rapid setup. It features a 12-step counterbalance system with a 2.8" (70 mm) sliding plate for perfect balance, and 5 steps of drag plus zero in both axes for whip pans. Tap holes let you mount an optional viewfinder extension adapter, and the Touch & Go quick-release system makes mounting and take down a non-issue: no fumbling, no struggling, no worries.

DV 12 SB Fluid Head (Mfr # 1205; B&H # SADV12SB)**2784.95**



Video 15 SB

The Video 15 SB, like the other SB (Speed Balance) heads, offers high-precision and extremely fast counterbalance for all digital camcorders from broadcast to Mini DV. Similar to the DV-12 SB, the Video 15 SB steps up with 7 steps of drag plus zero in both axes for whip pans, and a payload capacity of up to 35 lbs.

Video 15 SB Fluid Head (Mfr # 1505; B&H # SAV15SB)**3588.50**

SACHTLER

100MM FLUID HEADS



Video 18 SB

With the Video 18 SB fluid head, the latest technology is also available to heavier ENG cameras. This head offers significantly finer counterbalance graduation (10-step counterbalance) and a payload of up to 40 lbs. Fast, safe and reliable, the Video 18 SB has a frictionless damping system with seven levels of drag, offering maximum safety in fast-paced reporting situations. With its Touch & Go quick release system, you can attach and release your camera with one hand. The balance plate's sliding range of 120mm (4.7") lets you precisely compensate for a variety of configuration weights, while the self-illuminating Touch Bubble uses a conventional battery, ensuring easy leveling even under unfavorable lighting conditions.

Video 18 SB Fluid Head (Mfr # 1805; B&H # SAV18SB).....**4949.95**

Video 18 Dutch

Today, the normal shot just doesn't satisfy expectations anymore. Shots need to be thrilling, breathtaking, electrifying – camera language has become more spectacular. So why not take full advantage of breathtaking scenes and extraordinary settings? With Sachtler's Video 18 Dutch, you can do just that. The head for special effects provides you with seven steps of drag, even in conjunction with lateral tilt. The Video 18 Dutch features a cross-sliding plate with a sliding range of 60 mm / 2.4" to provide for precise camera control. Thus the camera's center of gravity can be exactly aligned over the swiveling axis. The head is able to tilt the horizon, and features a scale on its right side that shows the exact degree of third axis movement.

Video 18 Dutch Fluid Head (Mfr # 1804 • B&H# SAV18D)**3317.95**



Video 20 SB

The extremely flexible Video 20 SB can be used for EFP applications, because it combines an even greater level of carrying power with an increased carrying capacity. Do you need rear camera operation and on-camera viewfinder monitors? No problem for the powerful Video 20 SB. The Video 20 SB steps-up from the Video 18 SB with 12-step counterbalance and extremely high carrying capacity with a maximum payload of 55 lb. The Video 20 SB also has a long 120mm (4.7") balance plate sliding range.

Video 20 SB Fluid Head (Mfr # 2005; B&H # SAV20SB).....**6542.95**

Model	Payload	Weight	Tilt Range	Counterbalance	Drag	Bowl Diameter
DV 6 SB	20 lbs.	5.3 lbs.	+90/-75°	12 Steps	5+0	75mm
DV 8 SB	26 lbs.	5.5 lbs.	+90/-75°	12 Steps	5+0	75mm
DV 8 / 100 SB	26 lbs.	5.7 lbs.	+90/-75°	12 Steps	5+0	100mm
DV 12 SB	30 lbs.	6.0 lbs.	+90/-75°	12 Steps	5+0	100mm
Video 15 SB	35 lbs.	6.2 lbs.	+90/-75°	12 Steps	7+0	100mm
Video 18 SB	26 lbs.	7.3 lbs.	±90°	10 Steps	7+0	100mm
Video 18 Dutch	40 lbs.	5.7 lbs.	±80°	5 Steps	7+0	100mm
Video 20 SB	55 lbs.	7.5 lbs.	±90°	12 Steps	7+0	100mm

150MM FLUID HEADS



Video 25 Plus

With the Video 25 Plus and its 7-step, temperature-independent damping system, professional camera operators capture the naked truth with perfect clarity. Need to change position? Tilt angles up to 90° are no problem—even under maximum load. Fast, safe, and reliable, the Video 25 Plus displays an 18-step counterbalance that can be adjusted easily and safely in 9 stages via dial. Fine tuning is achieved via a half step function which can either be engaged or disengaged. The self-illuminating Touch Bubble helps you level the camera even in poor lighting conditions. With a maximum payload of 71 lbs. the Video 25 Plus is ideally suited to HDTV and wide screen cameras. For added convenience, a viewfinder extension mount is included.

Video 25 Plus Fluid Head (Mfr # 2500P; B&H # SA25P)**7142.95**

Video 25 Plus FB

The Video 25 Plus FB is unusually light for a studio / OB head. Its assembly lock mechanism lets you set up your equipment safely. It features horizontal and vertical brakes that are conveniently located at the rear side facing the studio camera operator) and easy to reach. The 4-hole bores are standard for TV equipment and allow you to use the head on all FB tripods. The Video 25 Plus FB is a featherweight that handles heavyweight cameras and camcorders. One of the fluid heads most frequently used by international television crews, it is easy to see that this head was created for combination with Pedestals Combi, CI and CIII. (Ball adapter available to mount on a tripod bowl.)

Video 25 Plus FB Fluid Head (Mfr # 2501P; B&H # SAV25PFB)**7039.95**



Video 60 Plus EFP • Video 60 Plus Studio

Extremely lightweight (weighs just 18.5 lbs.), the Video 60 Plus EFP has a 150mm center of gravity height to easily support up to 132 lbs. Balance plate has a sliding range of up to 115mm / 4.5", allowing you to safely balance the camera at any tilt angle. The 9-step damping system lets you move the camera gently, safely and friction-free – as quickly as the objects move. And tilt it wherever you want it to go. Follow the action, even when everything suddenly turns upside down. Easy to identify, direct-response horizontal and vertical brakes are vibration-free. Integrated assembly lock lets you mount the camera quickly and safely.

Its displays an 18-step counterbalance which can be adjusted easily and safely in 9 stages with the well known Sachtler dial. Fine-tuning is achieved via a half step function, which can either be engaged or disengaged. Finally, the head has a modular design, allowing you to change it for different applications. Modifications include, modify with V-plate; with pan bar with rosette; with flat base; with Mitchell fitting. The flat-base version of the Video 60 Plus EFP, the Video 60 Plus Studio is designed for OB and studio operation. It also comes with a V-Plate (the EFP version comes with a Touch & Go Plate 35) and has fatter pan arms (front section only).

Video 60 Plus EFP Fluid Head (Mfr # 6000; B&H # SAV60P)**8273.95** **Video 60 Plus Studio Fluid Head** (Mfr # 6001; B&H # SAV60PFB)**8167.95**

Video 75 Plus EFP • Video 75 Plus Studio

The Video 75 Plus EFP and Video 75 Plus Studio offer outstanding payload range of 25 to 190 lbs. Suitable for a variety of camera configurations and flexible applications in both EFP and studio operation, they offer users a broad palette of solutions. They display a 24-step plus Boost Button counterbalance which can be adjusted easily and safely in 12 stages with the well-known Sachtler dial. Fine-tuning is achieved via a half step function, which can either be engaged or disengaged. For even more precise adjustment the balance plate on the Video 75 Plus EFP has a sliding range of up to 120mm / 4.7", and up to 145mm / 5.7" for the Video 75 Plus Studio. This allows you to safely balance the camera at any tilt angle.

The Video 75 Plus EFP/Studio have a modular design, allowing you to change them for different applications. Various configuration options are available like; 150mm Ball Base with the Touch & Go quick release system and camera plate 35 wedge or Flat Base with the V-shaped wedge plate, or you can even mount it on a Mitchell Mount base.

Video 75 Plus EFP Fluid Head (Mfr # 7500; B&H # SAV75P)**9399.95** **Video 75 Plus Studio Fluid Head** (Mfr # 7501; B&H # SAV75PFB)**9877.95**



SACHTLER

150MM FLUID HEADS



Video 90 FB

Professional camera operators choose the Video 90 FB for OB and studio applications for good reason. Lightweight yet capable of supporting enormous loads up to 250 lbs. with 24-step counterbalance, it features simple, sturdy, squeeze-proof construction, and unsurpassed leak-proof, frictionless, maximum damping (7 grades +0) that is identical on the horizontal and vertical planes. A high-performance, jerk-free damping system is indispensable for long focal lengths in OB applications. Independent from the damping system, a 27-step counterbalance with fine tuning adjustments allows a variety of equipment to be used, and can be activated and deactivated individually.

The head features direct-response horizontal and vertical brakes. Mounted on the back of the head, they are absolutely vibration-free, thus guaranteeing exceptionally smooth operation. The integrated assembly lock lets you mount the camera quickly and safely, while a fine tuning knob ensures perfect counterbalance.

The Sachtler Quick fix lets you mount flat base heads with a single screw. This saves lots of time, especially if you have to change equipment quickly, which is all in a day's work in OB environments. Interface for teleprompter mounting allows you to place the teleprompter right next to the rotating axis. Need to use counterweights? This is also no problem for the Video 90 FB, which supports maximum loads up to 250 lbs.

Video 90 FB Fluid Head (Mfr # 8092; B&H # SAV90)**10,023.95**

Dutch Head 35

The Dutch Head 35 also features Sachtler's patented fluid damping and counterbalance systems. In addition, it has a cross-sliding plate that uses a high precision dove-tailed guidance with a sliding range of 60 mm / 2.4". This enables the camera's center of gravity to be aligned exactly over the head's swiveling axis. The head is able to tilt the horizon, and features a scale on the right side panel that shows the exact degree of third axis movement. Sachtler's patented damping system takes everything in its stride. The individual modules are frictionless and contain no hydraulic oil. This means they are permanently leak proof. The damping action of heads is identical across both horizontal and vertical planes and offers you five steps of drag, for smooth camerawork under the toughest of rough conditions. You can completely disengage the drag for fast panning without affecting the dynamic counterbalance system.

The sliding camera mount and plate with a 2.4" sliding range, allows the camera's center of gravity to be exactly aligned over the swiveling axis. Most importantly, once adjusted, the settings cannot be lost.



Dutch Head 35 Attachment (Mfr # 3004; B&H # SADHA)**4603.95**

Model	Payload	Weight	Tilt Range	Counterbalance	Drag	Bowl Diameter
Video 25 Plus	77 lbs.	9.9 lbs.	+90/-75°	18 Steps	7+0	150mm
Video 25 Plus FB	77 lbs.	9.9 lbs.	+90/-75°	18 Steps	7+0	150mm
Video 60 Plus EFP	143 lbs.	18.5 lbs.	+90/-60°	18 Steps	9+0	150mm
Video 60 Plus Studio	143 lbs.	20.7 lbs.	+90/-60°	18 Steps	9+0	150mm
Video 75 Plus EFP	187 lbs.	26.2 lbs.	+90/-60°	24 Steps	9+0	150mm
Video 75 Plus Studio	187 lbs.	28.4 lbs.	+90/-60°	24 Steps	9+0	150mm
Video 90 FB	254 lbs.	31.3 lbs.	+90/-45°	24 Steps	7+0	150mm
Dutch Head 35	110 lbs.	13.7 lbs.	±60°	8 Steps	8+0	150mm

FLUID HEADS for FILM

Cine 30 HD

Sachtler's fluid head Cine 30 HD features a side-load mechanism for the camera plate. A key advantage of this technology is that the fluid head can be side-loaded together with its camera set-up – quickly and easily. The mechanism is compatible with camera plates from OConnor and ARRI. The operating elements, manufactured according to 2K processes, are especially convenient. If you need a front box for all sorts of utensils or tools, it is simple to mount an adapter which is exceptionally practical for film and HD shooting. Any long-suffering camera assistant will appreciate the Sachtler Cine 30 HD 150mm fluid head and its unique side-load sliding camera plate. With the camera fully equipped, mounting and dismounting using the Snap & Go locking mechanism is safe, efficient, and worry-free. Fully compatible with Arri and OConnor camera plates, and features a fine adjustment for a tight, secure fit even if the plate is worn from use.

Counterbalance is accomplished with an 18-step selector dial and a high/low range lever for rapid, yet fine-tuned, repeatable setups. Horizontal and vertical drag is governed by a similar 7-step (plus zero) indexed selector system in conjunction with Sachtler's patented leak-proof frictionless cartridges, which carry a separate 2-year warranty. A tilt safety lock guarantees the integrity of the payload until it is secured, and caliper disk brakes ensure reliable pan and tilt fixing during operation with a quick flip of a short-throw lever. Naturally, the Cine 30 HD is covered by the standard Sachtler 2-year warranty, as well as comprehensive worldwide voice and web-based tech support, complete with CAD drawings, manuals, and service bulletins.



Cine 30 HD Fluid Head (150mm) - (Mfr # 3006 • B&H # SAC30HD)7,452.95



Cine 75HD

Classic film cameras are being increasingly replaced by high definition cameras in the area of movie production. Sachtler's fluid head Cine 75 HD is ideal for both types of production. The payload range of 4 to 75 kg / 9 to 165 lb also comes with a huge selection of accessories for the various cameras used with the head. And, of course, interfaces for a Front Box and viewfinder extension are standard accessories.

Cine 75 HD Fluid Head (150mm) - (Mfr# 7502 • B&H# SAC75HD)9,804.50

Studio 9+9

Ideal for 16 and 35mm film cameras, the Studio 9+9, features Sachtler's unique, patented damping system that has been significantly extended. As the name indicates, there are now nine levels of extra-powerful drag, ensuring perfect counterbalance in 18 steps. Levels 2 to 7 are fairly fine, while the jump from levels 7 to 9 is much greater.

The fluid head also boasts a new sliding plate, which has an integrated spindle drive. Centering the camera weight is now fast and easy - just slide the plate quickly into place and fine tune with the spindle drive if required. The counterbalance system combines the renowned Sachtler system with a dial knob system, compensating perfectly for any load up to 120 lb.

9+9 Fluid Head (150mm) - (Mfr# 6002 • B&H# SAS9P9)8,282.50



Model	Payload	Weight	Tilt Range	Counterbalance	Drag	Bowl Diameter
Cine 30 HD	77 lbs.	12.3 lbs.	+90/-75°	18 Steps	7+0	150mm
Cine 75 HD	165 lbs.	26.2 lbs.	+90/-60°	24 Steps	9+0	150mm
Studio 9+9	121 lbs.	18.5 lbs.	+90/-60°	18 Steps	9+0	150mm

SOOM

Multifunctional Camera Support System for Mini DV & HDV Camcorders

Developed to solve the shooter's dilemma of which type of camera support to transport to studio or location, Sachtler's innovative SOOM elegantly configures into 4 distinct support tools - all in one compact, easy-to-carry system.



1) For going low, the SOOM TriSpread mid-level spreader, which sports its own 75mm bowl, can be disconnected from the legs and used on its own as a low-level 2-stage "baby tripod" with a height range of 8" to nearly 19". Rubberized spikes assure firm footing.

2) Available as individual components or as a complete integrated system, the SOOM system includes the SOOM single-stage tripod with 75mm bowl ready to be mated to a Sachtler FSB or other fluid head. In this configuration, the SOOM TriPod provides a vertical height range from 27" to 56". The integrated TriSpread mid-level spreader delivers stability, even over uneven ground. There is a choice of removable rubber feet or hardened steel spikes.

3) The third part of the SOOM system is the SOOM Tube. The Tube looks like a small, automotive drive shaft with a universal joint on one end. It's a telescoping mono-pod with a retractable foot that the shooter can trap with their foot providing slip-proof operation. The "u-joint" on the top is actually another 75mm bowl where you can mount the tripod's pan/tilt head. Sports a range of 34" to 62", great for getting shots in places where a tripod just can't go, like in a crowd.

4) When you need more height, combining the SOOM TriPod with the SOOM Tube, deftly transforms into the SOOM HiPod capable of telescoping vertically to a variable lens height of over 8 feet. Thus it is ideal for shooting over obstacles or crowds. Sachtler incorporated a protective dampening feature that automatically deploys as the center column is collapsed, preventing the camera payload from crashing down.

This versatile Sachtler system may be reconfigured from one function to the next quickly and easily and without tools. SOOM's modularity not only gives the shooter freedom of spontaneous creativity, but also allows for a wide range of yet-to-be-developed accessories to expand the unit's functionality in the future. The SOOM system collapses to 37" for easy transportation in a single bag or case. The rugged SOOM system, featuring all 4 functions, weighs a total of 11.4 lbs (15.8 lbs with a Sachtler FSB 6 fluid head). When used in combination with the FSB 6 head, the system supports up to 13.2 lbs. For easy transport over long distances and through rough terrain, a custom-designed SOOM Bag featuring carrying straps, wheels and backpack straps is also available.

SOOM Tripod (26.8"-55.9") (Mfr # S2003-0003 • B&H # SASTP).....**799.95**

SOOM Tri-Spreader (Mfr # S2004-0001 • B&H # SAMLSQ)**428.95**

SOOM Tube (Mfr # S2005-0001 • B&H # SASHC)**489.95**

SOOM Tripod with SOOM Tri-Spreader and Carrying Case
(Mfr # 4160 • B&H # SASTTSC).....**1443.95**

Complete SOOM System with FSB-2: Includes the SOOM Tripod, SOOM Tri-Spreader, SOOM Tube, FSB-2 Fluid Head and Carrying Case. (Mfr # 0280 • B&H # SAFSB2S)**2509.95**

Complete SOOM System with FSB-6: Includes the SOOM Tripod, SOOM Tri-Spreader, SOOM Tube, FSB-6 Fluid Head and Carrying Case. (Mfr # 0480 • B&H # SAFSB6S)**3099.95**

Complete SOOM System: Includes SOOM Tripod, SOOM Tri-Spreader, SOOM Tube and Carrying Case (Mfr # 4161 • B&H # SASTTSHPC)**2178.95**

TRIPODS (75mm Bowl)

Sachtler tripods have proven themselves worldwide for over 45 years—whether in the Antarctic at temperatures of -40°C / -40°F or in the desert's scorching heat. Sachtler uses aluminum and carbon fiber for its tripods. Both materials stand out for their extraordinary resilience and extremely high safety against rupture. And because carbon fiber (CF) is exceptionally lightweight, it is the choice of camera operators who often need to travel. Carbon fiber has an additional advantage – it is more pleasant to hold at extremely low temperatures.

Single extension tripods usually have a rotary clamping system that secures each tripod leg in the required extension position within a matter of seconds. Double extension tripods are locked into place in a flash with Sachtler fast-action clamps, with the help of a lever specially designed for this purpose. The Speed Lock tripod also features an easy-to-use, patented clamping system. A single release lever operates the two fasteners on each leg of this double extension tripod. Depending on the payload, Sachtler tripods fit their fluid heads using a variety of connections. 75mm bowls are usually utilized with tripod systems that carry lightweight digital camcorders. 100mm fittings are widely used with tripods in ENG operation. Heavy film and television cameras find a reliable mount on tripods with 150mm fittings that, using adapters, can also be easily converted for different applications. Studio pedestals and OB tripods come with flat base for use with studio heads.

DA75/L • ENG 75/2D

With their compact dimensions, these tripods are indispensable companions for small Mini DV and HDV cameras. Used in combination with the FSB 2, FSB 6, DV6 SB and DV8 SB, the DA 75/L single extension with rotary clamp and ENG 75/2 D double extension with rotary clamp use Dural aluminum leg tubes to provide sturdy, lightweight support. Dural aluminum is an alloy employed in the manufacture of aircraft landing gear, and ensures great strength and reliability at a lower cost than carbon fiber. The tripods also incorporate the proven Touch & Go system enabling fast changeover, so camera operators can go from using the tripod to shooting from the shoulder within a matter of seconds.

DA 75/L Aluminum Tripod (Mfr # 4183; B&H # SADA75L)**463.50**

ENG 75/2D Two Stage Aluminum Tripod (Mfr # 4188; B&H # SADA752D)**712.95**

Speed Lock 75 CF

A professional tripod with the most compact dimensions on the market, the Speed Lock 75 CF is a fast, lightweight solution for MiniDV, HDV, DV CAM and DVCPRO ENG camcorders. Made from carbon fiber and therefore particularly lightweight, it also boasts smaller transport measurements than any other comparable tripod in its class. Designed for use with any fluid head that has a 75mm ball, it is a perfect companion for the Sachtler FSB 2, FSB 6, DV6 SB and DV8 SB heads.

The Speed Lock 75 CF is ideal for one-handed operation. And with its fast-action clamping system, it is ready to use within seconds. A clamp on each of the double-extension tripod legs releases and locks the leg with speed and precision. Just three clamps are used to lock the six clamping connections. In addition, an optional carrying strap with adjustable shoulder supports offers users the best possible carrying comfort.

Speed Lock 75 CF Carbon Fiber Tripod (Mfr # 4588; B&H # SASL75CF)**948.95**



Model	Payload	Weight	Material	Height	Folds to	Bowl Diameter
DA 75/L	33 lbs.	4.2 lbs.	Aluminum	55.9"	32.3"	75mm
DA 75/2D	44 lbs.	4.9 lbs.	Aluminum	57.9"	25.6"	75mm
Speed Lock 75 CF	44 lbs.	4.4 lbs.	Carbon Fiber	57.9"	25.6"	75mm

SACHTLER

TRIPODS (100mm Bowl)

DA Aluminum Single Stage Tripods

Dural aluminium (DA) 100mm single stage tripods are fitted with the Sachtler rotary clamping system which delivers the speed and mobility that news professionals and other users need. They come in a variety of sizes from the tiny DA 100 K, with its mini spreader, to the DA 100 L, which has a maximum height of 55.5". The DA 100 HD has a maximum load of 176 lb. A highly cost-effective alternative to carbon fiber tripods, standard dural aluminium tripods also have a tube diameter of 0.63", while HD (heavy-duty) versions have a tube diameter of 0.87".

Do you need to get down to a frog's perspective? The DA 100 K offers stability for extremely low shooting positions. And like all the others in the line, it also features the Sachtler rotary clamping system. You'll see and feel how securely your tripod is locked.

- DA-100M Medium Tripod Legs** (Mfr # 5151; B&H # SADA100M)**959.95**
- DA-100L Long Tripod Legs** (Mfr # 5182; B&H # SADA100L)**944.95**
- DA-100D Tripod Legs** (Mfr # 5480; B&H # SADA1002D)**1367.50**
- DA-100K Short Tripod Legs** (Mfr # 5122; B&H # SADA100S)**869.95**



Model	Payload	Weight	Material	Height	Folds to	Bowl Diameter
DA-100M	77 lbs.	4.9 lbs.	Aluminum	30.3"	20.1"	100mm
DA-100L	77 lbs.	6.4 lbs.	Aluminum	55.9"	32.3"	100mm
DA-100D	176 lbs.	9.7 lbs.	Aluminum	55.9"	32.3"	100mm
DA-100K	88 lbs.	3.3 lbs.	Aluminum	10.6"	8.7"	100mm

Carbon Fiber Single Stage Tripods

Sachtler's carbon fiber is especially twist-resistant since it is drawn out of one piece. Lighter and more stable than aluminum, carbon fiber offers maximum stability and carrying capacity. They also don't bend or corrode and are less influenced by temperature.

Sachtler carbon fiber single stage tripods are solid as a rock and light as a feather at the same time. For example, the CF 100 M weighs just 4 lb. and has a maximum load of 99 lb! The standard carbon fiber tripods CF 100 L and CF 100 M both have tube diameters of 0.63", while the HD version CF 100 HD has a tube diameter of 0.87" for a maximum load of 198 lb. All models in the line feature the Sachtler rotary clamping system which delivers the speed and mobility that news professionals and other users need.

- CF-100M Medium Tripod Legs** (Mfr # 5351; B&H # SACF100M)**1149.95**
- CF-100L Long Tripod Legs** (Mfr # 5382; B&H # SACF100L)**1358.50**
- CF-100HD Tripod Legs** (Mfr # 5380; B&H # SACF100HD)**1,474.95**



Model	Payload	Weight	Material	Height	Folds to	Bowl Diameter
CF-100M	99 lbs.	4.2 lbs.	Carbon Fiber	30.3"	20.1"	100mm
CF-100L	99 lbs.	5.3 lbs.	Carbon Fiber	55.9"	32.3"	100mm
CF-100HD	198 lbs.	8.2 lbs.	Carbon Fiber	55.9"	32.3"	100mm

TRIPODS (100mm Bowl)

ENG Aluminum and Carbon Fiber Two-Stage Tripods

Available in both dural aluminum and carbon fiber, two-stage tripods have an enlarged height range (lower bottom and higher top position), rendering them more universal. Locking of the legs is achieved in seconds by Sachtler's unique quick clamping system. In addition, their transport length is even shorter, and with their folding handle (ENG 2DHD and ENG 2CFHD only), you can easily carry the tripod in a horizontal position. Heavy-duty versions are available for extra stability. The heavy-duty aluminum tripod has a 20mm diameter tube vs. 16mm, and the heavy-duty carbon fiber model has a 24mm diameter tube vs. 22mm. For example, the ENG 2 D HD weighs just 10.8 lb, yet its continuous dual-tube design safely and stably carries payloads of up to 198 lb even at its maximum height of 61.8".



Model	Payload	Weight	Material	Height	Folds to	Bowl Diameter
ENG-2D	77 lbs.	6.8 lbs.	Aluminum	61.0"	27.6"	100mm
ENG-2D HD	198 lbs.	11 lbs.	Aluminum	63.4"	29.5"	100mm
ENG-2CF	88 lbs.	5.7 lbs.	Carbon-Fiber	61.0"	27.6"	100mm
ENG-2CF HD	209 lbs.	8.6 lbs.	Carbon-Fiber	63.4"	29.5"	100mm

ENG 2D Aluminum Tripod (Mfr # 5186 • B&H # SADA1002D).....**1199.95**
 ENG 2D HD Aluminum Tripod (Mfr # 5490 • B&H # SADA100HD2D)**1534.50**

ENG 2CF Carbon Fiber Tripod (Mfr # 5386 • B&H # SACF1002CF)**1299.95**
 ENG 2CF HD Carbon Fiber Tripod (Mfr # 5390 • B&H # SACF100HD2CF)....**1799.95**



Speed Lock CF • Speed Lock CF HD

The Speed Lock CF is the fastest two stage tripod in the world! Simply release the three easy to reach clamps and it is ready for action. This extremely sturdy and twist-resistant carbon fiber tripod ensures that you're already shooting while others are still setting up. It takes just three quick movements and the Speed Lock CF is ready for action – and you don't even have to bend over! The patented clamping system lets you adjust the tripod smoothly and safely, even with a camera mounted. Carbon fiber construction ensures minimal load-free weight, and increases stability and twist resistance. On top of that, the clamping connection forms a third tube to further increase stability. The ergonomically shaped, high-tech clamps have a rounded design which ensures that cables slide off without catching. In addition, you can tell at a glance whether the legs are clamped into position. The Speed Lock CF weighs less than 6.6 lb, only a few ounces more than the ENG 2 CF, highly favored by camera crews all over the world. And if you need strength, the HD model has an amazing clamping force of 209 lb. These tripods are, of course, compatible with all existing 100mm accessories.

Speed Lock CF 2 Stage Carbon Fiber Tripod Legs (Mfr # 5586 • B&H # SASLCF2) **1749.95**
 Speed Lock CF HD 2 Stage Heavy Duty Carbon Fiber Tripod Legs (Mfr # 5590 • B&H # SASLCF2HD).....**2153.50**



Model	Payload	Weight	Material	Height	Folds to	Bowl Diameter
Speed Lock CF	88 lbs.	6.8 lbs.	Carbon Fiber	61.0"	27.6"	100mm
Speed Lock CF HD	209 lbs.	11 lbs.	Carbon Fiber	63.4"	29.5"	100mm

Hot Pod CF

The fastest tripod in the world, the Hot Pod CF is the perfect companion for the DV 8/100, DV 12, DV 15 and Video 18 Plus/Sensor. All that's needed to change the fluid head is a touch of the button – no tools are required. With its centering function, the Hot Pod's locking system simultaneously releases and locks all three legs. The pneumatic center column easily lifts loads up to 40 lb. (Hot Pod CF10) or 55 lb. (Hot Pod CF14) to lens heights of over 6.6' and has a factory set elevation force that is maintenance free. And if you need to move quickly, the Hot Pod CF has both a handle and a strap for easy carrying.

Hot Pod CF 10 1-Stage Carbon Fiber Hot Pod Tripod Legs (Mfr # 538510; B&H # SAHPCF10)**2569.95**
 Hot Pod CF 14 1-Stage Carbon Fiber Hot Pod Tripod Legs (Mfr # 538514; B&H # SAHPCF14).....**2569.95**

TRIPODS (150mm Bowl)



DA Aluminum Single-Stage and Dual Stage Tripod Legs

Like the 100mm series, the three models in the dural aluminium (DA) 150mm series are designed to ensure that every perspective is covered. The DA-150K, for example, with its minimum height of just 6.3", enables shots from extremely low viewing angles.

- DA-150L** Long Tripod Legs (Mfr # 6192; B&H # SADA150L) **1359.95**
- DA-150ML** Medium-Long Tripod Legs (Mfr # 6181; B&H # SADA150ML) **1247.95**
- DA-150K** Short Tripod Legs (Mfr # 6132; B&H # SADA150S) **1064.95**
- EFP-2D** Aluminum Dual-Stage Legs (Mfr # 6186; B&H # SADA1502D) **1455.95**

Carbon Fiber Single Stage and Two-Stage Tripod Legs

Like the 100mm series, Sachtler's 150mm carbon fiber single stage tripods are solid as a rock and light as a feather at the same time.

- CF-150L** Long Carbon Fiber Tripod Legs (Mfr # 6392; B&H # SACF150L) **1757.50**
- CF-150ML** Medium Carbon Fiber Legs (Mfr # 6381; B&H # SADA150ML) **1649.95**
- EFP-2CF** Carbon Fiber Dual-Stage Legs (Mfr # 6386; B&H # SACF1502CF) ... **1841.95**

Cine 150 • Cine 2000

With their all-metal construction and large 35mm/1.4" tube diameter, the Cine 150 and Cine 2000 are extremely stable tripods. Oversized rotary stage clamps ensure dependable leg fixing and ease of use, even with gloved hands. Each leg is tipped with long stainless steel spikes for a firm footing in soft, unstable ground, and pivot stiffness is adjustable with convenient fold-away levers. The different height ranges of the Cine 150 Medium and Long complement each other, allowing use in various of applications. The Cine 2000 Short offers a minimum height of 6.7" making it ideal to keep the tripod footprint to a minimum.

- Cine 150 Long** Aluminum Tripod Legs (Mfr # 6290; B&H # SAC150L) **1968.95**
- Cine 150 Medium** Aluminum Tripod Legs (Mfr # 6250; B&H # SAC150M) ... **1744.95**
- Cine 2000 Short** Aluminum Tripod Legs (Mfr # 6232; B&H # SAC2000S) .. **1588.95**

Cine Mitchell

Otherwise the same as their Cine 150 Medium and Cine 150 Long counterparts, the Cine Mitchell Medium and Long are designed for fluid heads with Mitchell or flat base fittings as well as gear heads.

- Cine Mitchell Medium** Tripod Legs (Mfr # 6255 • B&H # SACMM) **1859.50**
- Cine Mitchell Long** Tripod Legs (Mfr # 6295 • B&H # SACML) **2007.95**

OB 2000 for OB and studio applications

The OB 2000 is the tripod for heavy cameras. The single stage, heavy duty, flat-base tripod has a built-in stabilizer which can hold a hand crank column and lock it into place. Rotating rubber feet are built into the tripod legs. Built-in bubble and tripod leg scaling provide simple and precise leveling. The OB 2000 supports all common flat-base heads, including Mitchell video fittings, which do not require an adapter. Also includes a mid-level spreader.

- OB 2000** Aluminum Tripod Legs (Mfr # 6481 • B&H # SAOB2000) **2689.95**

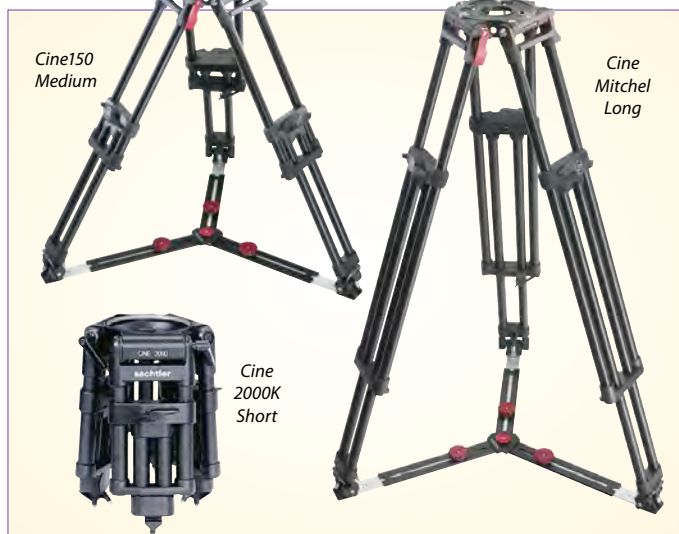

OB 2000 Center Column Hand Crank

Height adjustments with complex camera configurations are rarely easy. Extending the legs can be very difficult, and at times impossible without help. But with the OB 2000 hand crank column, you will glide to the top! All you have to do is crank your camera to the desired height. The 14.2" lift range extends the maximum height of the OB 2000 to 67.7". The built-in stabilizer of the OB 2000 holds the hand crank column.

A brace which anchors the tripod to the pedestal tower is built into the base of the column guide tube. The hand crank column complies with all safety regulations observed by TV broadcasters and is compatible with all common flat base heads, as well as the Sachtler Quickfix mount.

- Center Column Hand Crank** (Mfr # 6205 • B&H # SACCOB2000) **2499.95**

PEDESTALS

Picture transmission needs to be first rate, even during vertical camera movement. Sachtler pedestals enable smooth, precise and jerk-free height adjustment. Our full range of weight classes, designs and accessories ensures outstanding performance for all applications, from video studios right up to OB vans.



Pedestal C I

The C I combines a tripod with a pneumatic central column. The air pressure inside the central column can be adjusted to suit the exact weight of your configuration, so the camera actually floats on a cushion of air. A brake locks the central column in any position, while a transport latch lets you carry the pedestal safely, even when the central column is under pressure. The maintenance-free central column rests on six ball bearings, two of which can be adjusted to ensure jerk-free motion even after long, intensive shoots. Each bearing is coated with hard rubber to absorb sliding noises.

C I System (Flat Base) with Dolly 75 (Mfr #4191 • B&H # SAP14).....2199.95

Pedestal C III

The C III is ideal for industrial studios and user-friendly mobile studios. The C III lifting column moves so smoothly you can even operate it while shooting. Its extensive adjustment range, silent dolly and fast, tool-free assembly and disassembly ensure ideal conditions for outstanding pictures – in any location. You can combine the C III with any Sachtler fluid head, even the Video 60 Plus, dependent only on your camera load.

C III with Dolly XL- (Mfr #5195 • B&H # SAPEDC3)7194.95

Combi Ped 1-40

Thanks to its modular design, the lightweight Combi Ped 1-40 is ideal for EFP and OB portable use. The compact construction provides maximum stability at a low weight. The Combi Ped 1-40 provides crab steering functionality to provide simple manoeuvring. The pedestal enables smooth and vibration-free height adjustment. A column brake locks the column in any position. A transport latch keeps the pedestal securely in position during transport. An air pump is included, providing convenient pressurization of the pedestal at any location. The Combi Ped 1-40 setup is tool-free: The dolly and column can be easily connected using eccentric clamps, and engaging the steering column.

- ◆ The Combi Ped 1-40 is a steerable (crab) pedestal. The steering ring can be detached easily for transportation. Four trim weights are included as standard with the pedestal, and can be put in the trim weight storage pockets on the steering ring to compensate for variations in temperature during a production.
- ◆ 5" wheels with easy to adjust cable guards and individual wheel brakes.
- ◆ Pressure gauge provides easy monitoring of air pressure inside the column. A pressure relief valve prevents damage caused by overfilling.

Combi Ped 1-40 (Mfr #2473)CALL



Specifications	Pedestal C I	Pedestal C III	Combi 1-40
Weight	20.3 lbs.	36.4 lbs.	54 lbs.
Payload	44.1 lbs.	121 lbs.	88 lbs.
Height Range	26.8" – 61.8"	28.1" – 61.8"	31.1" – 52.4"
Lift	15.4"	16.5"	16.5"
Clearance	36.6"	39"	27.5"
Head Fitting	Flat Base	Flat Base	Flat Base

VARIO PED 2-75 • STUDIO PED 2-75

Two-Stage Steering Pedestals with Vario or Studio Pedestal Dolly

Your pedestal affects the quality of your work. Highly stable, yet light-weight, Sachtler's Vario and Studio pedestals provide optimum support in both OB and studio environments. Perfectly suited for all weights and sizes of modern broadcast cameras, each pedestal has a built-in Quickfix attachment which ensures fast setup, while the large column diameters provide exceptional stability. Air-filled columns make them far safer than gas-filled pedestals. In addition, a pressure relief valve prevents damage caused by overpumping.



Vario Ped

Sachtler thought of everything! Do you need to change heads? A column latch and Quickfix attachment make this even faster. And fast vertical panning is child's play with the friction damping systems. In addition, the crab-and-steer function enables simple maneuvering with defined rolling turns. In order to enable balancing during the shoot – for example in case of sudden temperature change – the steering wheel has easily accessible slots for the balance weights (included). Narrow clearance is not a problem, as the dolly arm positions are easy to adjust. Even the power cable features extra padding to protect it from being crushed. The steering wheel, column, and dolly quickly disassemble for transport.

Studio Ped

Studio pedestals are not only incredibly simple to use – they are extremely user-friendly too. Camera operators can easily view the wheel positions at all times and operate the three individual wheel brakes from any position. The crab-and-steer function enables simple maneuvering with defined rolling turns. The power cable, of course, features extra padding to protect it from being crushed. In addition, most of the pedestal surfaces are rubber coated so you can push the unit with your feet, and the balance weights are covered in plastic to avoid contact with lead. A small steering wheel is available and can even be used with a teleprompter. It takes just a few minutes to convert the Studio Ped into a Vario Ped for mobile use or to replace the standard studio wheels with large OB wheels or air wheels.

FEATURES

- ◆ Their modular design allows the steering wheel, column and dolly to be assembled in seconds without tools. Due to the increased weight, the Studio Pedestals provide just the right feel for maneuvering in the studio, while keeping all the advantages of an OB pedestal – narrow track ability, in particular.
- ◆ They are steered by a removable hand wheel on which holders are fitted for trim weights to compensate for temperature changes during a shooting session.
- ◆ A column lock and Sachtler Quickfix mount for fast changes of the fluid head are standard, as is the friction damping which prevents unwanted movement of the column during rapid tilting.
- ◆ Whether on hard rubber wheels or optional pneumatic tires, the Vario Peds can shrink to 27" doorway clearance for narrow passages. The Dolly base may be folded for easy transport. Crab and steer switching, individual wheel brakes and cable guards are standard on both pedestals.

Studio Pedestal Only

- ◆ The Studio Pedestal has all the advantages of the Vario series and combine the feel of a traditional pedestals with a kick strip to maneuver the pedestal by foot.
- ◆ The large, flat dolly surface eases camera setup by providing a platform for accessories and better visibility of the wheels and thus the steering direction.

Specifications	Vario Pedestal 2-75	Studio Pedestal 2-75
Weight	121 lbs.	181 lbs.
Payload	165 lbs.	165 lbs.
Height Range	26.0" – 56.3"	26.0" – 56.3"
Lift	30.3"	30.3"
Clearance	27.2" – 36.2"	35"
Head Fitting	Flat Base, Quickfix	Flat Base, Quickfix

The Vario 2-75 and Studio 2-75 are "true" two-stage pedestals, offering an extended 'on air' stroke of 30", with a load capacity of 165 lbs. The height range of the Vario and Studio pedestals allows horizontal cameras to shoot people sitting or standing.

Vario Pedestal 2-75 System (Quick Fix) with Vario Dolly (Mfr# 5201 • B&H# SAVARPED275) **17,999.95**
Studio Pedestal 2-75 System (Quick Fix) with Studio Pad Dolly (Mfr# 5275 • B&H# SASP75) **19,999.95**

TRIPOD SYSTEMS

FSB-2 (supports up 4.4 lbs.) and FSB-6 (up to 13.2 lbs.) Tripod Systems

FSB-2 Aluminum Tripod System

Consists of:
FSB-2 Fluid Head, 1-Stage Tripod, Mid-Level Spreader and Padded Case. (Mfr # 0272 • B&H # SAFSB2ML1S)**799.95**

FSB-2 Aluminum Tripod System

Consists of:
FSB-2 Fluid Head, 2-Stage Tripod, Mid-Level Spreader and Padded Case. (Mfr # 0273 • B&H # SAFSB2ML2S)**954.95**

FSB-2 FSB-2 Carbon Fiber Tripod System

Consists of:
FSB-2 Fluid Head, 2-Stage Tripod, Mid-Level Spreader and Padded Case. (Mfr # 0275 • B&H # SAFSB2ML2CFS).....**1149.95**



FSB-6 Aluminum Tripod System - consists of:

FSB-6 Fluid Head, 2-Stage Tripod, Mid-Level Spreader and Padded Case (Mfr # 0473 • B&H # SAFSB6ML2S)**1439.95**

FSB-6 Aluminum Tripod System - consists of:

FSB-6 Fluid Head, 1-Stage Tripod, Mid-Level Spreader and Padded Case (Mfr # 0472 • B&H # SAFSB6ML1S)**1399.95**

FSB-6 Aluminum Tripod System - consists of:

FSB-6 Fluid Head, 2-Stage Tripod, Mid-Level Spreader and Padded Case (Mfr # 0443 • B&H # SAFSB6TML2S)**1499.95**

FSB-6 Carbon Fiber Tripod System - consists of:

FSB-6 Fluid Head, 2-Stage Tripod, Mid-Level Spreader and Padded Case (Mfr # 0475 • B&H # SAFSB6ML2CFS)**1699.95**

DV-6SB (up to 20 lbs.), DV-8SB (to 26 lbs.) & 12SB (to 30 lbs.) Tripod Systems

DV-6SB Aluminum Tripod System - consists of: DV-6SB Fluid Head, DA-75L 1-Stage Tripod, Mid-Level Spreader and Hard Case (Mfr # 0642 • B&H # SADV6SB1S)**1719.95**

DV-6SB/2D Aluminum Tripod System - consists of: DV-6SB Fluid Head, DA-75/2D ENG 2-Stage Tripod, Mid-Level Spreader and Hard Case. (Mfr # 0643 • B&H # SADV6SB2S).....**1899.95**

DV-6SB SL Carbon Fiber Tripod System - consists of: DV-6SB Fluid Head, Speed Lock 75CF 2-Stage Tripod, Mid-Level Spreader and Softcase. (Mfr # 0650 • B&H # SADV6SBSLMCF).....**2149.95**

DV-8SB Aluminum Tripod System - consists of: DV-8SB Fluid Head, DA-75L 1-Stage Tripod, Mid-Level Spreader and Hard Case (Mfr # 0842 • B&H # SADV8SB1S)**2449.95**

DV-8SB/2D Aluminum Tripod System - consists of: DV-8SB Fluid Head, DA-75/2D ENG 2-Stage Tripod, Mid-Level Spreader and Hardcase. (Mfr # 0843 • B&H # SADV8SB2S).....**2599.95**

DV-8SB SL Carbon Fiber Tripod System - consists of: DV-8SB Fluid Head, Speed Lock 75CF 2-Stage Tripod, Mid-Level Spreader and Softcase. (Mfr # 0850 • B&H # SADV8SBSLMCF).....**2959.95**

DV-8SB Aluminum Tripod System - consists of: DV-8SB Fluid Head, DA-100L 1-Stage Tripod, On-Ground Spreader, and Hard Case. (Mfr # 0860 • B&H # SADV8100SB).....**3799.95**

DV-8SB ENG Carbon Fiber Tripod System - consists of: DV-8SB Fluid Head, ENG 2CF 2-Stage Tripod, On-Ground Spreader, and Hard Case. (Mfr # 0662 • B&H # SADV8100SBFCF)**4767.95**



DV 12 SB Fluid Head



DV 8 SB Fluid Head



DV-6SB Tripod System

DV-12SB Aluminum Tripod System - consists of:

DV-12SB Fluid Head, DA-100L 1-Stage Tripod, On-Ground Spreader, and Case. (Mfr # 1260 • B&H # SADV12SB5S).....**4505.50**

DV-12SB ENG Carbon Fiber Tripod System - consists of: DV-12SB Fluid Head, ENG 2CF 2-Stage Tripod, On-Ground Spreader, and Hard Case. (Mfr # 1262 • B&H # SADV12SB2CF)**5001.95**

DV-12SB ENG Carbon Fiber Tripod System - consists of: DV-12SB Fluid Head, ENG 2CF 2-Stage Tripod, Mid-Level Spreader, Rubber Feet and Soft Case. (Mfr # 1263 • B&H # SADV12SB2MCF)**5499.95**

DV-12SB SL Carbon Fiber Tripod System - consists of: DV-12SB Fluid Head, Speed-Lock CF 2-Stage Tripod, Mid-Level Spreader, Rubber Feet and Case. (Mfr # 1265 • B&H # SADV12SBSLMC)**5999.95**

DV-12SB Carbon Fiber Hot-Pod Tripod System - consists of: DV-12SB Fluid Head, 1-Stage Hot-Pod 10 Tripod, with Integrated Mid-Level Spreader, and Case. (Mfr # 1214 • B&H # SADV12SBHP)**5099.95**

V-12SB SL Carbon Fiber Tripod System - consists of: DV-12SB Fluid Head, Speed-Lock CF 2-Stage Tripod, Mid-Level Spreader, Rubber Feet and Case. (Mfr # 1265 • B&H # SADV12SBSLMC)**5989.95**

TRIPOD SYSTEMS

Video 15SB (up to 35 lbs.) and System 18 (up to 45 lbs.) Tripod Systems

Video-15SB Hot-Pod Carbon Fiber Tripod System - consists of: Video-15SB Fluid Head, 1-Stage Hot-Pod 14 Tripod with integrated Mid-Level Spreader and Hardcase - (Mfr # 1514 • B&H # SAS15PSBHP).....**6249.95**

Video-15SB Aluminum Tripod System - consists of: Video-15SB Fluid Head, DA-100 ENG 2D 2-Stage Tripod, On-Ground Spreader, and Case (Mfr # 1561 • B&H # SAS15PSBENG2)**4946.95**

Video-15SB ENG Carbon Fiber Tripod System - consists of: Video-15SB Fluid Head, ENG 2CF 2-Stage Tripod, On-Ground Spreader, and Hard Case (Mfr # 1562 • B&H # SAS15PSBENG2)**5599.95**

Video-15SB Carbon Fiber Tripod System - consists of: Video-15SB Fluid Head, ENG 2CF 2-Stage Tripod, Mid-Level Spreader, Rubber Feet and Case (Mfr # 1563 • B&H # SAS15PSBENMC)**6594.95**

Video-15SB Carbon Fiber Tripod System - consists of: Video-15SB Fluid Head, Speed-Lock CF 2-Stage Tripod, Mid-Level Spreader, Rubber Feet and Case - (Mfr # 1565 • B&H # SAS15SBSLMCF).....**6699.95**



18 PLUS Carbon Fiber Hot-Pod System - consists of: Video 18 Plus Fluid Head, 1-Stage Hot-Pod Tripod with Integrated Mid-Level Spreader and Hardcase. (Mfr # 1820US • B&H # SASYST18NC)**7559.95**

System 18/1861- Includes Video 18 SB Fluid Head, ENG 2D Tripod, Ground-Level Spreader, and ENG-2 Cover- (Mfr # 1861 • B&H # SASY18SB2D).....**6897.95**

System 18/1864- Includes Video 18 SB Fluid Head, Speed Lock CF tripod, Ground Spreader, and Padded Bag. (Mfr # 1864 • B&H # SAS18SBSL).....**7399.95**

System 18/1862- Includes Video 18 SB Fluid Head, ENG 2 CF Tripod, Ground-Level Spreader, and Padded Bag. (Mfr # 1862 • B&H # SASY18SB2CF)**7369.95**

System 18/1863- Includes Video 18 SB Fluid Head, ENG 2 CF Tripod, Mid-Level Spreader, Rubber Feet, and Padded Bag. (Mfr # 1863 • B&H # SAS18SBENG2M).....**7639.95**

System 18/1865- Includes Video 18 SB Fluid Head, Speed Lock CF tripod with rubber feet, 100/150 Mid-Level Spreader, and Padded Bag. (Mfr # 1865 • B&H # SAS18SBSLMCF).....**8119.50**

System 15 / 20 / 25 / 60 / 75 / 90 Tripod Systems

System 15 SB C III- Video 15 SB and Pedestal C III- Supports 35 lbs (Mfr # 1570; B&H # SAS15SBC3).....**10,347.95**

20 SB HD CF Carbon Fiber Tripod System - Video 20 SB Fluid Head, ENG-2 CF HD 1-Stage Tripod, On-Ground Spreader and Soft Bag - Supports 55 lbs (Mfr # 2072 • B&H # SAS20SBHDCF)**9006.50**

System 20/2062- Includes Video 20 SB Fluid Head, ENG-2 CF tripod, SP-100 Ground-Level Spreader, and Padded Bag- Supports 55 lbs (Mfr # 2062 • B&H # SAS20SBENG2)**8564.95**

System 20/2073- Includes Video 20 SB Fluid Head, ENG-2 CF HD tripod with rubber feet, 100/150 Mid-Level Spreader, Padded Bag- Supports 55 lbs (Mfr # 2073 • B&H # SAS20SBHDMCF)**9613.50**

System 20/2074 Includes Video 20 SB Fluid Head, Speed Lock CF HD, SP 100/150 Ground Spreader, Padded Bag- Supports up to 55 lbs (Mfr # 2074 • B&H # SAS20SBSLHD) **8995.95**

System 20/2075 Same as above except with SP 100/150 Mid-Level Spreader (Mfr # 2075 • B&H # SAS20SBSLMCF) ..**9869.95**

25 PLUS Carbon Fiber Tripod System - consists of: Video 25 Plus Fluid Head, EFP-2CF 2-Stage Tripod, On-Ground Spreader and Hardcase - Supports 11-77.2 lbs (Mfr # 2512 • B&H # SAS25)**9845.95**



Video 25 Plus Head



System 60 OB-2000

Cine 75 HD Aluminum Tripod System
Cine 75 HD Fluid Head, Cine-2000L 1-Stage Tripod and On-Ground Spreader - Supports 9-165 lbs. (Mfr # 7522 • B&H # SAS75HD)**CALL**

60 PLUS Carbon Fiber Tripod System - consists of: Video 60 Plus Fluid Head, EFP-2CF 2-Stage Tripod, On-Ground Spreader and Hardcase - Supports 35-143.3 lbs. (Mfr # 6012 • B&H # SAS60)**11,176.95**

60 OB Aluminum Tripod System - Video 60 Plus Fluid Head, OB-2000 1-Stage Tripod and Dolly - Supports 35-143 lbs. (Mfr # 6095 • B&H # SAS60OB2000)**12,699.95**

75 PLUS EFP Carbon Fiber Tripod System - consists of: Video 75 Plus EFP Fluid Head, EFP-2CF 2-Stage Tripod, On-Ground Spreader and Hardcase - Supports 25-178.6 lbs. (Mfr # 7512 • B&H # SAS75P)**12,009.95**

75 PLUS OB-2000 Aluminum Tripod System - consists of: Video 75 Plus Studio Fluid Head, OB-2000 1-Stage Tripod and Dolly - Supports 25-187.4 lbs. (Mfr # 7595 • B&H # SAS75POB2000).....**14,107.50**

90 OB Aluminum Tripod System - Video 90 FB Fluid Head, OB-2000 1-Stage Tripod and Dolly - Supports up to 253.5 lbs. (Mfr # 8095 • B&H # SAS90OB).....**14,783.95**

ACCESSORIES

Mid-Level and On-Ground Spreaders

An on-ground spreader is used when shooting is performed on a level surface, such as studio, city streets, offices, sport fields and stadiums. It allows for rapid set-up and pull down by keeping tripod legs at an equal or preset distance relative to each other. Attaches directly to the feet at the bottom of a tripod and its arms are telescopic to allow extension of a tripod leg without detaching the spreader.

Mid-level spreader Kit: Includes mid-level spreader and 3 rubber feet for the for the Speed Lock 75 CF, ENG 75/2 D and DA 75 tripods. (Mfr # 7011 • B&H # SAMLS)**204.95**

Spreader SP 75: On-Ground spreader for all 75mm Bowl Tripods and Pedestal C I (Mfr # 7001 • B&H # SASP14)**209.95**

Spreader SP 100: On-Ground spreader for all 100mm Bowl Tripods (Except DA-100 Short Tripod) (Mfr # 7002 • B&H # SASP100)**449.95**

Mini Spreader SP 100: On-Ground for DA-100 Short Tripod (Mfr # 7002K • B&H # SASPMINI) ...**434.95**

Spreader SP 100/150: Heavy-Duty On-Ground Spreader - for all 100mm and 150mm tripods (except Short, OB-2000/M and Cine 2000 tripods) (Mfr # 7003 • B&H # SASP100150)**537.95**

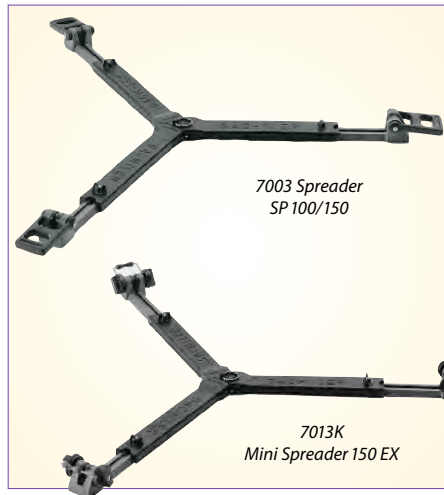

Mini Spreader 150

Heavy-Duty On-Ground Spreader for DA-100 and DA-150 Short (Mfr # 7003K; B&H # SASP100150Q)**549.95**

Mini Spreader EX

On-Ground spreader for Cine 2000 Short Tripod (Mfr # 7013K; B&H # SAMSEX)**609.95**

Spreader SP 150 EX

On-Ground spreader for OB-2000/M, Cine 2000 and Cine 2000 Medium Tripods (Except Cine 2000 Short) (Mfr # 7013; B&H # SASP150EX)**579.95**

Mid-Level Tripod Spreader

For all Tripods 100mm and 150mm Bowl, OB-2000M, Cine 2000 (Except Short Tripods) (Mfr # 7007; B&H # SASP100OG)**599.95**

Dollies

Dolly DV 75: Provides smooth and stable dolly action for all 75mm (for DA-75L, DA-75/2D and Pedestal C I) tripods. Features independent wheel locks and are foot controllable that lets you fix the direction of one, two or all three wheels. A collapsed length of 25" enhances portability, while the ergonomically designed carry handle is molded into the dolly's reinforced center bracket for optimum carriage strength. (Mfr # 7063; B&H # SAD75)**489.95**

Dolly DV 100: Provides smooth and stable dolly action for all 100mm tripods. Features independent wheel locks and are foot controllable that lets you fix the direction of one, two or all three wheels. Collapses to 26" enhancing portability, while the ergonomically designed carry handle is molded into the dolly's reinforced center bracket for optimum carriage strength. (Mfr # 7067; B&H # SADDV100)**857.50**

Dolly S: Provides smooth and stable dolly action for most 100 and 150mm tripods (except Hot-Pod, DA-100/150 Short, OB-2000/M and Cine 2000 tripods). Features fast-action foot-operated brakes, adjustable cable guards and is fitted with track



locks to provide tricycle steering. A collapsed length of only 26" enhances portability, while the ergonomically designed carry handle is molded into the dolly's reinforced center bracket for optimum carriage strength. (Mfr # 7065; B&H # SADS)**1384.95**

Dolly XL: Provides smooth and stable dolly action for the OB-2000, OB-2000M and Cine 2000 tripods. Features fast-action foot-operated brakes, adjustable cable guards and is fitted with track locks to provide tricycle steering. A collapsed length of 28" enhances portability, while the ergonomically designed carry handle is molded into the dolly's reinforced center bracket for optimum carriage strength. (Mfr # 7080; B&H # SADXL)**2204.95**

Hot Pod Dolly: Provides smooth and stable dolly action for all Hot-Pod tripods. Features fast-action foot-operated brakes, adjustable cable guards and is fitted with track locks to provide tricycle steering. A collapsed length of only 21" enhances portability, while the ergonomically designed carry handle is molded into the dolly's reinforced center bracket for optimum carriage strength. (Mfr # 7066; B&H # SADHP)**1393.50**

ACCESSORIES

Rubber Feet

Snap these feet onto your tripod when it's not possible to use the dual spiked feet, ideal on slippery and glossy floors.

7004 Rubber Feet: Set of 3 for all Tripods with Off-Ground Spreaders (Except OB-2000/M and Cine 2000/M Tripods)
(Mfr # 7004; B&H # SARF7004)**349.95**



7014 Rubber Feet EX: Set of 3, for OB-2000, OB-2000M, Cine 2000 Cine 2000M tripods.
(Mfr # 7014; B&H # SARF7014)**339.95**

Pan Bars

0992 Pan Bar DV75: for DV-1, DV-2 II, DV-4 II, DV-6, DV-8 and DV 8/100 Fluid Heads.
(Mfr # 0992; B&H # SAPADV2)**89.95**

1075 Pan Bar DV 100: for DV-12, DV-15 and Video 14 Fluid Heads.
(Mfr # 1075; B&H # SAPAV14)**148.95**

3470 Pan Bar DV Right (telescopic): for all DV Fluid Heads (Mfr # 3470; B&H # SATRPBDV)**356.95**

3471 Pan Bar DV Left (telescopic): for all DV Fluid Heads. (Mfr # 3471; B&H # SATLPBDV)**356.95**

3270 Pan Bar PLUS Right (telescopic): for DV-12, DV-15, Caddy, Video 18/20 all versions, Video 25 Plus, Video 60 Plus, Panorama Plus, Horizon Plus, Dutch 35 and Video 18 Dutch Fluid Heads. (Mfr # 3270; B&H # SARPAV18)**356.95**



3271 Pan Bar PLUS Left (telescopic): For DV-12, DV-15, Caddy, Video 18/20 all versions, Video 25 Plus, Video 60 Plus, Panorama Plus, Horizon Plus, Dutch 35 and Video 18 Dutch Fluid Heads.
(Mfr # 3271; B&H # SALPAV18)**356.95**

3170 Pan Bar MOVIE Right: For Studio 9+9 and Studio 80 II Fluid Heads.
(Mfr # 3170; B&H # SAPAS80)**526.95**

3172 Front Pan Bar: Front-Mounted Short Cine-Style Pan Bar Handle for Cine 75 HD and Video 75 Plus EFP Fluid Heads.
(Mfr # 3172; B&H # SAFBPC75HD)**327.95**

Camera Plates and Adapters

1464 Camera Plate DV 8: Touch and Go Wedge Plate for DV-8, DV-8/100 and Video 14/75 Fluid Heads.
(Mfr # 1464; B&H # SA1464)**79.95**

1465 C.O.G. Plate DV: Center of Gravity (C.O.G.) Touch and Go Wedge Plate for DV-2, DV-4 and DV-6 Fluid Heads.
(Mfr # 1465; B&H # SA1465)**224.95**

1064 Camera Plate 16: Touch and Go Wedge Plate for Caddy, DV-12, DV-15, Video 18, Video 20, Panorama Plus, Horizon Plus, Video 25 and Video 18 Dutch Fluid Heads.
(Mfr # 1064; B&H # SA1064)**94.95**

1063 C.O.G. Plate 16: Center of Gravity (C.O.G.) Touch and Go Wedge Plate - for DV-12, DV-15, Caddy, Video 18, Video 20 and Video 25 Fluid Heads. (Mfr # 1063; B&H # SA1063)**249.95**

3051 Camera Plate 35: Touch and Go Wedge Plate for Video 25 Plus FB, Video 60 and 75 Plus EFP, Cine 75 HD, Studio 9+9, Studio 80 and Dutch Head 35 Fluid Heads.
(Mfr # 3051; B&H # SA3051)**174.95**

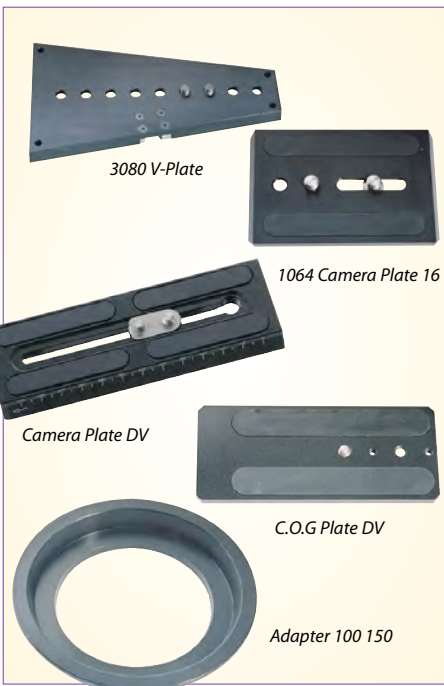

3080 V-Plate: Touch and Go Wedge Plate for Video 60 Plus Studio and Video 90 Fluid Heads.
(Mfr # 3080; B&H # SA3080)**373.50**

6050 Studio Set-Up Video 60 Plus: Platform with V-Shaped Wedge Plate - to convert Video 60 Plus EFP to Video 60 Plus Studio.
(Mfr # 6050; B&H # SASSUV60)**1295.95**

6051 EFP Set-Up Video 60 Plus: Platform with Camera Plate 35 - to convert Video 60 Plus Studio to Video 60 Plus EFP.
(Mfr # 6051; B&H # AESUV60)**1087.95**

7550 Studio Set-Up Video 75 Plus: Platform with V-Shaped Wedge Plate - to convert Video 75 Plus EFP to Video 75 Plus Studio.
(Mfr # 7550; B&H # SASSUV75P)**1295.95**

7551 EFP Set-Up Video 75 Plus: Platform with Camera Plate 35 - to convert Video 75 Plus Studio to Video 75 Plus EFP.
(Mfr # 7551; B&H # SAESUV75P)**1087.95**

1091 Sandwich Touch and Go: Adapter with Camera Plate 16 (#1064).
(Mfr # 1091; B&H # SA1091)**319.95**

ACCESSORIES

Viewfinder Extensions/ Converters / Adapters

Adapter Viewfinder Extension 12/15: 3980
Viewfinder Extension Adapter for Video 15 SB
and DV 12 SB fluid heads
(Mfr # 3980; B&H # SAAVFEDV12)**64.95**

Adapter Viewfinder Extension 18/20: for
Video 18 Plus and Video 20 Plus fluid heads
(Mfr # 3981; B&H # SAAVFEDV18P)**64.95**

FB Converter: for Video 18/20 Plus heads on
pedestals and OB tripods (except Pedestal C I)
(Mfr # 3913; B&H # SAAVFEDV18P)**64.95**

Multi Disc: Universal Flat Base adapter for the
DV-8/100, DV-12, DV-15, Video 18 & 20 III FB,
Video 25 Plus and Video 60 Plus onto the
Pedestal CII, Combi Ped and Vario Pedestal.
(Mfr # 3914; B&H # SAMD)**213.95**

Quickfix Adapter: Gives a Quickfix mount for
the Video 25 Plus, Video 60 Plus and Video 90,
to mount them on the OB 2000 tripods or
Pedestal CII (Mfr # 3910; B&H # SA3910)**759.95**

Adapter Ped C I/DV: Allows use of DV 8/100,
DV 12, DV 15 and Video 15 Plus heads on
Pedestal C I (Mfr # 1030; B&H # SAP14DVA)**58.95**

Adapter Ped C I/Plus: Allows use of the Video
18 and 20 (Plus and Sensor) fluid heads onto
the Pedestal C I. (Mfr # 3941; B&H # SAP14A) ...**169.95**

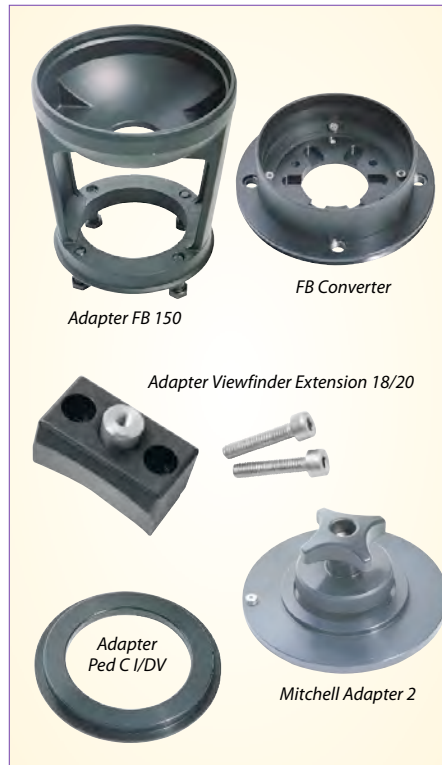

Adapter 75/100: Allows 75mm ball base fluid
heads to be used on tripods with 100mm
bowl (Mfr # 3906; B&H # SA3906)**189.95**

Adapter 100/150: Allows 100mm ball base
fluid heads to be used on tripods with 150mm
bowl (Mfr # 3901; B&H # SA3901)**244.95**

Adapter FB/100: Allows 100mm ball base
fluid heads to be used on FB tripods and
pedestals (Multi Disc is required for C II
Pedestal). (Mfr # 3903; B&H # SAFBA100MM) ...**169.95**

Adapter FB/150: Allows 150mm ball base
fluid heads to be used on FB tripods and
pedestals (Mfr # 3908; B&H # SAFBA150MM)**244.95**

Mitchell Adapter Plate: Allows Cine 75 HD,
Studio 9+9 and Horizon Plus to be used on
Mitchell tripod (Mfr # 3902; B&H # SAMAP).....**319.95**

Mitchell Adapter piece with Locking Knob:
For Cine 75 HD, Studio 9+9, Video 75 Plus EFP
and Video 60 Plus EFP to be used on Mitchell
tripods (Mfr # 6053; B&H # SAMAV60)**52.95**

Cable Clamp V 60: To organize expensive,
heavy signal and power cables with the Video
60 fluid head. (Mfr # 6054; B&H # SACCV60)**179.50**

Cable Clamp V/C 75: Same as above with the
Video 75 Plus and Cine 75 HD fluid heads (Mfr #
6055; B&H # SACCV75P)**179.50**

Cover 100 II: Hard plastic case to ship a DV-8
/100, DV-12, DV-15, all Video 15/18/20 and
Panorama versions on 100 Long or HD tripods
with spreader and Hot Pod. It has an
adjustable top cover with about a 3.5" leeway.
(Mfr # 9309; B&H # SAC100)**459.50**

Cover ENG 2: For DV-8 /100, DV-12, DV-15, all
Video 15/18/20 and Panorama versions on ENG
2 and Speed Lock CF tripods, and DV-6, DV-8,
DV-12, DV-15, Video 15/18 on Pedestal C I. (Mfr
9311; B&H # SACENG2)**439.95**

Cover 100M: Hard plastic case designed to
ship a Sachtler 100mm medium ball tripod
with a spreader.
(Mfr # 9214; B&H # SAC100M)**286.50**

Cover 150SE: Hard plastic case to ship a
Sachtler 150mm medium ball tripod with a
spreader (without fluid head), or Dolly S and
Dolly DV-100. (Mfr # 9316; B&H # SAC150SE)**373.50**

Tripod Cases and Bags



Padded Bag ENG 2: Soft padded tripod carry
bag for ENG 75/2D tripod DV-2 II, DV-4 II or DV
8/75mm head, or DV 8 with 100mm ball, DV-12,
DV-15, Video-15, Video-18, Video-20 fluid heads
on 2-fold extension or Speed Lock CF tripods.
Bag is carried by interlocking handles or
attached shoulder strap.
(Mfr # 9104; B&H # INPG9104)**269.95**

Padded Bag ENG/EFP:
For DV 8 with 100mm ball, DV-12, DV-15, Video-
15, Video-18, Video-20 fluid heads on 100 mm
long, 100 HD, Hot Pod tripods; DV-8 wit 100mm
ball, DV-12, DV-15, Video-15, Video-18, Video-20
fluid heads on ENG 2 HD, Speed Lock CF HD
tripods; Horizon Plus and Video 25 Plus fluid
heads on 2-fold extension EFP 2 tripods. strap.
Bag is carried by interlocking handles or
attached shoulder strap.
(Mfr # 9106; B&H # SAPBEFP)**563.50**

SLIK-DAIWA

FLUID HEADS

DAIWA 05 — 75mm Spring Balance System



Constructed from durable all-metal material, the Daiwa-05 fluid head is designed to provide smooth performance for today's lightweight digital camcorders. Features a preset counterbalance system, procuring perfect balance for camera's ranging between 3 to 11 lbs. It also offers an integrated counterbalance system with +90/-72 tilt angle, a 75mm claw ball base, as well as a quick release system for quick setup and disengagement of your camera.

- ◆ Durable all-metal head construction handles a recommended load of 4 to 11 lbs.
- ◆ Sliding camera mount plate with 50mm of movement forward or rearward for balance.
- ◆ Professional disk type pan and tilt brake
- ◆ Pre-set counter balance and movement drag
- ◆ Includes Telescopic Pan Bar (#PH05L) and Camera Mounting Plate (#PKS05)

Daiwa-05 Fluid Head (75mm Ball Base) - Supports 11 lbs (Mfr# DAIWA05 • B&H# SLD05).....699.00

DAIWA 06 — 75mm Spring Balance System

Perfect for independent TV productions using Mini DV camcorders, the Daiwa-06 fluid head provides smooth effortless professional performance, quality lightweight construction and simple operating procedures. You literally mount the camera, slide the plate to balance, aim and shoot. Features a preset counterbalance system providing perfect balance for today's DV and HDV camcorders ranging between 8 and 19 lbs. Also offers high viscosity fluid drag pan and tilt system and quick release plate with ±2.5 inches of adjustment for perfect horizontal counterbalance.

- ◆ Reliable spring balance system with simple to operate pre-set counter balance and drag / friction for lighter weight cameras.
- ◆ Compact professional fluid head made from aluminum die-casting.
- ◆ Smooth fluid movements with separate locks for pan and tilt.
- ◆ Tilttable control handle, 75mm claw ball base and spirit level.
- ◆ Includes Telescopic Pan Bar (#PH10L) and Camera Mounting Plate (#PKS06).

Daiwa-06 Fluid Head (75mm Ball Base). Supports 19 lbs (Mfr# DAIWA06 • B&H# SLD06).....849.00



DAIWA 08 — 75mm Cam Balance System



Constructed from die-cast all-metal material, the Daiwa-08 fluid head is designed to provide smooth performance, for today's on-the-move compact ENG camcorders. It features an infinitely adjustable counterbalance system, procuring perfect balance for camera's ranging between 13 to 22 lbs. Variable viscosity drag pan and tilt system, providing infinite and repeatable adjustments and can be adjusted down to "zero" setting. Comes with a tilting and telescopic control handle, 75mm claw ball base, quick release camera plate with safety lock and spirit level.

- ◆ Professional Cam Balance system creates smooth performance with a full range of drag controls for tilt and pan movements
- ◆ Compact design and all metal construction.
- ◆ Designed for outstanding performance with DV/HDV cameras weighing 13 to 20 lbs.
- ◆ Includes Telescopic Pan Bar (#PH10L) and Camera Mounting Plate (#PKS08)

Daiwa-08 Fluid Head (75mm Ball Base) - Supports 20 lbs (Mfr# DAIWA08 • B&H# SLD08)CALL

Model	Payload	Weight	Tilt Range	Drag	Bowl Diameter
DAIWA 05	11 lbs.	3.6 lbs.	+90/-72°	Constant Viscosity	75mm
DAIWA 06	17 lbs.	5.06 lbs.	+90/-68°	Constant Viscosity	75mm
DAIWA 08	20 lbs.	7.04 lbs.	+90/-75°	Variable Viscosity	75mm

FLUID HEADS

DAIWA 11 — 100mm Cam Balance System

Designed to meet the requirements of today's camera operator, the Daiwa-11 fluid head, with its load capacity of up to 29 lb. is ideal for ENG/EFP dockable camera's with long lenses and batteries. Perfectly counterbalanced through a tilt range of +90/-60°, with an infinite and repeatable pan and tilt friction, provides unsurpassed smoothness and personalized feel. The Daiwa-11 comes with telescopic pan handle, quick release plate, spirit level and 100mm ball base, that allows it to be mounted on any tripod with a 100 mm bowl.

- ◆ Superior performance with cameras weighing 13 to 25 lbs.
- ◆ Once mounted and balanced, the camera load is perfectly counter balanced throughout the tilt range of +90° to -60°
- ◆ Full range of controls including infinitely adjustable drag for tilt and pan movements
- ◆ Includes Telescopic Pan Bar (#PH10L) and Camera Mounting Plate (#PKS10)

Daiwa-11 Fluid Head (100 mm Ball Base) - Supports 25 lb (Mfr# DAIWA11 • B&H# SLD11).....2359.00



DAIWA 15 — 100mm Cam Balance System



Designed to meet the requisite needs of the ENG/EFP operator, the Daiwa-15 fluid head, with its load capacity of up to 33 lbs. is ideal for the latest portable digital camera configurations used in professional broadcast, educational and corporate productions. Perfectly counterbalanced through a tilt range of +90/-60 degrees, achieving perfect balance for camera's ranging between 18 to 33 lbs. Variable viscosity drag pan and tilt system provides unsurpassed smoothness and personalized feel. The Daiwa-15 fluid head comes with telescopic pan handle, quick release plate, spirit level and 100mm ball base, that allows it to be mounted on any tripod with a 100mm bowl.

- ◆ Excellent heavy-duty fluid head for both ENG and EFP / Studio applications
- ◆ Perfect counter balance for DV camcorders throughout the tilt range of +90° to -60°
- ◆ Unsurpassed smoothness with infinitely adjustable and repeatable drag settings
- ◆ Includes Telescopic Pan Bar (#PH10L) and Camera Mounting Plate (#PKS10)

Daiwa-15 Fluid Head (100mm Ball Base) - Supports 33 lbs (Mfr# DAIWA15 • B&H# SLD15).....3299.00

DAIWA EP56 — 100mm Cam Balance System

Designed to meet the needs of the ENG/EFP operator, the Daiwa-15 utilizes space age die-cast alloys, composites, titanium and bronze materials, to bring about lightweight design and construction, for outstanding quality, reliability and performance. Ideal for the latest portable digital camera configurations used in professional broadcast, educational and corporate productions, the head is perfectly counterbalanced through a tilt range of +90/-60 degrees, achieving perfect balance for camera's ranging between 18 to 33 lbs. Variable viscosity drag pan and tilt system.

- ◆ Sliding quick release plate with safety lock provides ±2.5 inches of adjustment, for perfect horizontal counterbalance.
- ◆ Variable and repeatable viscosity fluid drag system, ensures perfect pictures while pan and tilt movements, without jerks and vibrations.
- ◆ Once set on the right setting you can always go back, with the line markings on the adjustment knobs.
- ◆ Built-in spirit level, for easy horizontal leveling
- ◆ Includes Telescopic Pan Bar (#PH10L) and Camera Mounting Plate (#PKS10)

Daiwa-EP56 Fluid Head (100 mm)- Supports 48.5 lb (22 kg) (Mfr# EP56 • B&H# SLDEP56)3399.00



Model	Payload	Weight	Tilt Range	Drag	Bowl Diameter
DAIWA 11	25 lbs.	9.25 lbs.	+90/-60°	Variable Viscosity	100mm
DAIWA 15	33 lbs.	9.25 lbs.	+90/-60°	Variable Viscosity	100mm
DAIWA EP56	48.5 lbs.	9.25 lbs.	+90/-60°	Variable Viscosity	100mm

TRIPOD LEGS

207 • 307

Lightweight Single and Dual-Stage Tripods

The 207 (single-stage) and 307 (dual-stage) tripods are constructed from hard-anodized aluminum alloy leg tubing in conjunction with composite moldings and bronze bearing surfaces, providing superior structural integrity and unsurpassed reliability. They feature a leg locking design that won't permit slippage or over compression (leg damage) and can be field adjusted. The leg pivots are self-adjusting. With dual stage design, the 307 tripod adds the capability of getting close to the ground for low-angle shots. They includes a removable ,mid-level spreader, dual spike tips, and a 75mm claw ball bowl.

- ◆ Durable all aluminum rail construction
- ◆ Single- and dual-stage design for fast set-up and fold down
- ◆ Mid-level spreader included (removable)
- ◆ 75mm bowl for mounting heads
- ◆ Maximum height of 55.8" (207) and 58" (307)
- ◆ Support up to 28 lbs
- ◆ Perfect for Daiwa 05, 06 and Daiwa 08 heads

207 1-Stage Tripod Legs (75mm Bowl) with Mid-Level Spreader (Mfr# 207 • B&H# SL207)**499.00**

307 2-Stage Tripod Legs (75mm Bowl) with Mid-Level Spreader (Mfr# 307 • B&H# SL307)**599.00**

209 • 309

Lightweight Single and Dual-Stage Tripods

The 209 (single-stage) and 309 (dual-stage) tripods are constructed from hard-anodized aluminum alloy leg tubing in conjunction with composite moldings and bronze bearing surfaces, providing superior structural integrity and unsurpassed reliability. studio applications. Their leg lock design prevents slippage or over compression and is field adjustable by the camera person. Leg pivot assemblies are self-adjusting. With dual-stage design, the 309 tripod adds the capability of getting close to the ground for low-angle shots.

- ◆ Durable all aluminum rail construction
- ◆ Single-stage and dual-stage design for fast set-up and fold down
- ◆ 100mm bowl for mounting heads
- ◆ Maximum height of 61.1" (209) and 62" (309)
- ◆ They support up to 55 lbs.
- ◆ Perfect for Daiwa 11, Daiwa 15 and other heads with 100mm mount

209 1-Stage Tripod Legs (100 mm Bowl)- Supports 55 lb (Mfr# 209 • B&H# SL209)**649.00**

309 2-Stage Tripod Legs (100mm Bowl)- Supports 55 lb (Mfr# 309 • B&H# SL309)**739.00**

100DW 2C Super Lightweight Carbon Fiber Legs

The 100DW2C is a carbon fiber tripod which utilizes a single stage leg design, mid-level spreader and composite molded fittings, permitting virtually no radial motion or instability.

- ◆ Maximum height of 62 inches
- ◆ Two leg sections for greater capacity
- ◆ 100mm bowl for mounting heads
- ◆ Perfect for the Daiwa EP56, Daiwa 15, Daiwa 11 and other heads with 100mm mount

100DW 2C Carbon Fiber 1-Stage Tripod Legs (100mm Bowl) (Mfr# 100DW2C • B&H# SL100DW2C) .**999.00**

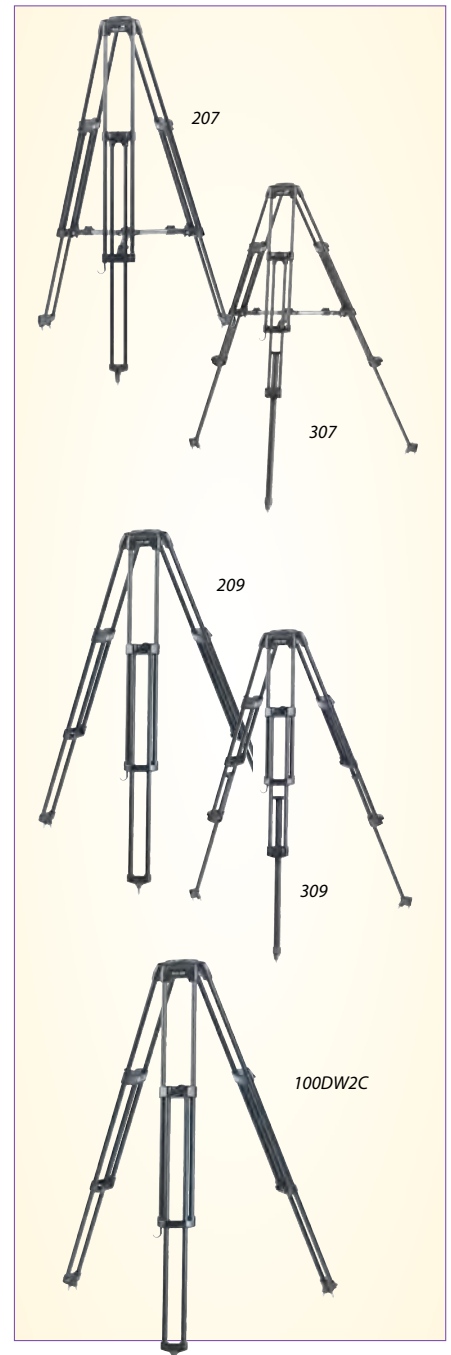

Model	Payload	Weight	Material	Height	Folds to	Bowl Diameter
207	28 lbs.	6.16 lbs.	Aluminum	55.8"	33"	75mm
307	28 lbs.	6.61 lbs.	Aluminum	58"	27.6"	75mm
209	55 lbs.	7.92 lbs.	Aluminum	61.14"	37.5"	100mm
309	55 lbs.	8.14 lbs.	Aluminum	62"	28.3"	100mm
100DW 2C	55 lbs.	6 lbs.	Carbon Fiber	62"	35.2"	100mm

TRIPOD SYSTEMS

Daiwa-05 Aluminum Tripod System (Mfr # DW5M1; B&H # SLD05M1)
Consists of Daiwa-05 Fluid Head, 207 tripod, mid-level spreader and 1030-UL soft-sided heavy-duty nylon tripod case.....**1099.00**

Daiwa-05 Aluminum Tripod System (Mfr # DW5F1; B&H # SLD05F1)
Consists of Daiwa-05 Fluid Head, 207 tripod, FL-9 on-ground spreader and 1030-UL soft-sided heavy-duty nylon tripod case.....**1249.00**

Daiwa-05 Aluminum Tripod System (Mfr # DW5M2; B&H # SLD05M2)
Consists of Daiwa-05 Fluid Head, 307 tripod, mid-level spreader and 890-7 soft-sided heavy-duty nylon tripod case.....**CALL**

Daiwa-05 Aluminum Tripod System (Mfr # DW5F2; B&H # SLD05F2)
Consists of Daiwa-05 Fluid Head, 307 tripod, FL-9 on-ground spreader and 890-7 soft-sided heavy-duty nylon tripod case.....**CALL**

Daiwa-06 Aluminum Tripod System (Mfr # DW6M1; B&H # SLD06M1)
Consists of Daiwa-06 Fluid Head, 207 tripod, mid-level spreader and 1030-UL soft-sided heavy-duty nylon tripod case.....**1299.00**

Daiwa-06 Aluminum Tripod System (Mfr # DW6F1; B&H # SLD06F1)
Consists of Daiwa-06 Fluid Head, 207 tripod, FL-9 on-ground spreader and 1030-UL soft-sided heavy-duty nylon tripod case.....**1499.00**

Daiwa-06 Aluminum Tripod System (Mfr # DW6M2; B&H # SLD06M2)
Consists of Daiwa-06 Fluid Head, 307 tripod, mid-level spreader and 890-7 soft-sided heavy-duty nylon tripod case.....**1499.00**

Daiwa-06 Aluminum Tripod System (Mfr # DW6F2; B&H # SLD06F2)
Consists of Daiwa-06 Fluid Head, 307 tripod, FL-9 on-ground spreader and 890-7 soft-sided heavy-duty nylon tripod case.....**1699.00**

Daiwa-08 Aluminum Tripod System (Mfr # DW8M1; B&H # SLD08M1)
Consists of Daiwa-08 Fluid Head, 207 tripod, mid-level spreader and 1030-UL soft-sided heavy-duty nylon tripod case.....**2199.00**

Daiwa-08 Aluminum Tripod System (Mfr # DW8F1; B&H # SLD08F1)
Consists of Daiwa-08 Fluid Head, 207 tripod, FL-9 on-ground spreader and 1030-UL soft-sided heavy-duty nylon tripod case.....**2399.00**

Daiwa-08 Aluminum Tripod System (Mfr # DW8M2; B&H # SLD08M2)
Consists of Daiwa-08 Fluid Head, 307 tripod, mid-level spreader and 890-7 soft-sided heavy-duty nylon tripod case.....**2399.00**

Daiwa-08 Aluminum Tripod System (Mfr # DW8F2; B&H # SLD08F2)
Consists of Daiwa-08 Fluid Head, 307 tripod, FL-9 on-ground spreader and 890-7 soft-sided heavy-duty nylon tripod case.....**2599.00**

Daiwa-11 Aluminum Tripod System (Mfr # DW11M1; B&H # SLD11M1)
Consists of Daiwa-11 Fluid Head, 209 tripod, ML-9 mid-level spreader and 1080-9 soft-sided heavy-duty nylon tripod case.....**3199.00**

Daiwa-11 Aluminum Tripod System (Mfr # DW11F1; B&H # SLD11F1)
Consists of Daiwa-11 Fluid Head, 209 tripod, FL-9 on-ground spreader and 1080-9 soft-sided heavy-duty nylon tripod case.....**3149.00**



Daiwa-11 Aluminum Tripod System (Mfr # DW11M2; B&H # SLD11M2)
Consists of Daiwa-11 Fluid Head, 309 tripod, ML-9 mid-level spreader and 890-9 soft-sided heavy-duty nylon tripod case.....**3249.00**

Daiwa-11 Aluminum Tripod System (Mfr # DW11F2; B&H # SLD11F2)
Consists of Daiwa-11 Fluid Head, 309 tripod, FL-9 on-ground spreader and 890-9 soft-sided heavy-duty nylon tripod case.....**3199.00**

Daiwa-11 Tripod System (Mfr # DW11D1; B&H # SLD11D1)
Consists of Daiwa-11 Fluid Head, 209 tripod and DY9 dolly.....**3299.00**

Daiwa-11 Carbon Fiber Tripod System (Mfr # DW11M3 • B&H # SLD11M3)
Consists of Daiwa-11 Fluid Head, 100DW 2C tripod, ML-9 mid-level spreader and 1080-9 soft-sided heavy-duty nylon tripod case.....**3549.00**

Daiwa-11 Carbon Fiber Tripod System (Mfr # DW11F3 • B&H # SLD11F3)
Consists of Daiwa-11 Fluid Head, 100DW 2C tripod, FL-9 on-ground spreader and 1080-9 soft-sided heavy-duty nylon tripod case.....**3499.00**

Daiwa-15 Aluminum Tripod System (Mfr # DW15M1 • B&H # SLD15M1)
Consists of: Daiwa-15 Fluid Head, 209 1-Stage Tripod, ML-9 mid-level spreader and 1080-9 Softcase - Supports 33 lbs.....**Call**

Daiwa-15 Aluminum Tripod System (Mfr # DW15M1 • B&H # SLD15M1)
Consists of: Daiwa-15 Fluid Head, 309 2-Stage Tripod, ML-9 mid-level spreader and 1080-9 Softcase - Supports 33 lbs.....**3780.95**

Daiwa-15 Aluminum Tripod System (Mfr # DW15F1 • B&H # SLD15F1)
Consists of: Daiwa-15 Fluid Head, 209 1-Stage Tripod, FL-9 on-ground spreader and 1080-9 Softcase - Supports 33 lbs.....**3849.00**

Daiwa-15 Aluminum Tripod System (Mfr # DW15F2 • B&H # SLD15F2)
Consists of: Daiwa-15 Fluid Head, 309 2-Stage Tripod, FL-9 on-ground spreader and 1080-9 Softcase - Supports 33 lbs.....**3899.95**

Daiwa-EP56 Aluminum Tripod System (Mfr # DWEP56M1 • B&H # SLDEP56M1)
Consists of: Daiwa-EP56 Fluid Head, 209 1-Stage Tripod, Mid-Level Spreader and Softcase - Supports 35.2 lbs.....**4299.00**

Daiwa-EP56 Aluminum Tripod System (Mfr # DWEP56M2 • B&H # SLDEP56M2)
- consists of: Daiwa-EP56 Fluid Head, 309 3-Stage Tripod, Mid-Level Spreader and Softcase - Supports 35.2 lbs.....**4299.95**

ACCESSORIES

Camera Mount Plates (repl.)

- PKS05** for Daiwa 05 Head
(Mfr# PKS05 • B&H# SLPKS05)**95.95**
- PKS08** for Daiwa 08 Head
(Mfr# PKS08 • B&H# SLPKS08)**109.95**
- PKS10** for Daiwa 11 and Daiwa 15 Heads
(Mfr# PKS10 • B&H# SLPKS10)**129.95**

Foot Pads

Snap these foot pads onto your tripod legs when it isn't possible to use the dual spiked feet. Ideal on slippery and glossy floors. Sold singularly. For use with all Daiwa tripods
(Mfr# FOOTPAD • B&H# SLFP)**ea. 34.95**

PH10L Pan Handle

Left-handed (reversible for right-handed users) telescoping pan handle for Daiwa 06, 08, 11, 15 and EP56 fluid heads
(Mfr# PH10L • B&H# SLPH10L)**119.95**

CLAMP HEAD 38

The CLAMP HEAD 38 is perfect for attaching small LCD monitors, to a light stand, railing, or tripod leg or even branch that has a diameter of 1.5" or less. It has a 2-way pan head that allows it to be locked in a wide variety of positions. Its all-metal construction will hold up for years of use.



(Mfr# 618-020 • B&H# SLCH38)**49.95**

Carrying Cases



Heavy nylon soft-sided case fitting the 207 tripod with smaller fluid heads like the Daiwa 05, 06, 08 (Mfr # CASE1030UL • B&H # SL1030UL)..**42.95**

Heavy nylon soft-sided case with reinforced sides fitting the 209 tripod with heavy-duty fluid heads like the Daiwa 11 and 15
(Mfr # CASE10809 • B&H # SL10809).....**156.95**

Heavy nylon soft-sided case with reinforced sides fitting the 307 and 309 tripod legs with the Daiwa 11 and 15 heavy-duty fluid heads
(Mfr # CASE8909 • B&H # SL8909).....**139.95**

DY7 and DY-9 Dollies

The DY-7 and DY-9 are designed for quiet, smooth and effortless tripod movement on studio floors. All wheel castors utilize non-marking, non-setting polyurethane tires mounted on stainless steel rims rotating on needle bearings. Each wheel has positive locking in both radial & axial rotation with step-on step-off design. Each dolly leg folds from a carrying position to 120-degree lock position with each leg terminating with a positive tripod leg lock (tapered cone) and clamping device. Wheel diameter is 3.9" (100mm) and radius is 18.5" (470mm)

DY-7 Medium-weight dolly (8.8 lbs.) for use with 207 and 307 tripods (Mfr# DY7 • B&H# SLDY7) ..**349.00**

DY-9 Heavy-duty dolly (12.1 lbs.) for use with 209 / 207 and 309 / 307 tripods
(Mfr# DY9 • B&H# SLDY9)**479.00**

ML-9 Mid-Level Spreader

Designed for the 209 and 309 tripods, the ML-9 is used when shooting on uneven surfaces such as steps, rocky ground, and inclines. It allows for rapid set-up and take-down by keeping tripod legs at an equal or preset distance relative to each other. It attaches to the center bracket of a tripod and it has telescoping arms, allowing extension of a tripod leg without detaching the spreader.

ML-9 Adjustable Mid-Level Tripod Spreader with Foot Pads - for 209 and 309 Tripods
(Mfr# ML9 • B&H# SLML9).....**224.95**

FL-9 Floor Spreader

Designed for the 207, 209, 307 and 309 tripods, the FL-9 is used when shooting on level surface, such as studios, city streets, offices, sport fields and stadiums. Rubber foot pads provide added stability on smooth surfaces. The FL-9 allows for rapid set-up and take-down by keeping tripod legs at an equal or preset distance relative to each other. It attaches directly to the feet at the bottom of a tripod and its arms are telescopic to allow extension of a tripod leg without detaching the spreader.

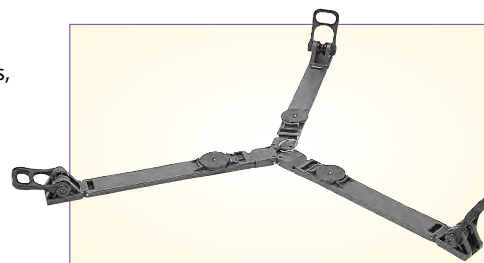

FL-9 On-Ground Tripod Spreader - for 207, 209, 307 and 309 Tripods (Mfr# FL9 • B&H# SLFL9)**164.95**

DHR-9 Remote Control Pan Handle

The DHR-9 combines zoom lens control with one-touch operation built into the pan handle. This puts controls, such as REC/RET and zoom, right at your fingertips. This allows videographers to operate both camera movement and recording controls with the same hand — freeing them to take care of creative decisions rather than having to worry about how to reach the camera buttons, follow the subject, and keep movements smooth all at the same time. Also available for Vinten and Sachtler heads.



- ◆ Ergonomic, telescoping panhandle, supports firm direction of both pan & tilt moves.
- ◆ Provides off-camera control of both record and zoom (tele/wide) functions
- ◆ Adapts to most Canon and Fujinon ENG lenses with 8-pin connectors (optional 8-pin to 12-pin adapter, will conform to many Fujinon Broadcast lenses)

DHR-9: Remote Control Pan Handle for Slik Daiwa Heads (Mfr# DHR9 • B&H# SLDHR9)**369.95**

SHR-9: Remote Control Pan Handle for Sachtler Heads (Mfr # SHR9 • B&H # SLSHR9)**412.50**

VHR-9: Remote Control Pan Handle for Vinten Heads (Mfr # VHR9 • B&H # SLVHR9)**369.95**

SPIDER SUPPORT SYSTEMS

SPIDER POD

Portable Tripod Riser and Standing Platform

A portable tripod riser and standing platform, the Spider Pod elevates a camera tripod and operator two feet. Designed for professional videographers, filmmakers and news crews who need to raise their camera's viewpoint with speed and stability, it allows a camera operator to shoot above crowds and capture images that are stable and unobstructed.

Large staging risers are often used as camera platforms. However, as an operator shifts footing, the camera and tripod may shake producing an unstable video image. When multiple shooters are on these shaky staging risers or camera are zoomed in, the problem is magnified. The Spider Pod features a separate tripod riser and standing platform eliminating camera shake caused by the camera operator.

- ◆ Setting up within 30 seconds, Spider Pod supports all standard tripods with spreaders or feet.
- ◆ Riser and platform measure 3.5 x 28 x 28", weigh 41 lbs.

- ◆ Tripod riser supports up to 200 lbs., the standing platform supports up to 300 lbs.

Spider Pod (Mfr # TR2SP2 • B&H # SPSP)**2019.95**



EXPANSION WEB Expanded Standing Platform System for the Spider Pod

Designed for those who need the portability of the Spider Pod, but require a larger standing area. Based on a modular concept, the Expansion Web provides many advantages over a traditional riser. The 2' x 2' square panels interlock in a variety of configurations to accommodate the full spectrum of shooting needs. This set of four panels provides a 4' x 4' platform area. Like the Spider Pod, the Expansion Web is separated from the tripod riser which eliminates any potential shake caused by operator movement. The modules form a platform large enough to accommodate a chair or stool for longer shooting times.

operator movement. The modules form a platform large enough to accommodate a chair or stool for longer shooting times.

Portability makes the Expansion Web an ideal choice for remote broadcast needs, corporate video departments, and staging companies. It eliminates the need for a staging riser, sets up quickly, and is easy to transport and store. Various configurations are possible for total mobility around your tripod. Made of high-quality component materials, such as anodized aluminum and a carpeted slip-resistant surface, each modular square is designed to interlock with the others for a strong and stable standing platform. The ability to interlock from all four sides is key to its versatility and portability.

Expansion Web for Spider Pod: Includes four 2 x 2' square panels (Mfr # EW • B&H # SPEWS)**2199.95**

Tripod Riser and Expansion Web (Mfr # TR2EW • B&H # SPSPEW)**3399.95**

SCORPION POD

One-Piece Portable Tripod Riser and Standing Platform

A one-piece portable tripod riser and standing platform, the Scorpion Pod elevates a camera tripod and operator two feet. Designed for professional videographers and news crews who need to raise their camera's viewpoint with speed and stability, the Scorpion Pod brings the camera lens and operator's view clearly above the crowd.

Based on the Spider Pod's award-winning features, the Scorpion Pod consumes a small footprint of space on the floor, and can be easily set-up by one person in less than 30 seconds. Unique to the Scorpion Pod is its one-piece design. By integrating the tripod riser and standing platform, the weight of the unit is reduced making it easier to carry and set-up.

Scorpion Pod (Mfr # SCP • B&H # SPSPS)**1289.95**



TRIPOD SYSTEM

Renowned for their innovative design of pan and tilt heads, tripods and pedestals, Vinten's philosophy has always been to design camera support equipment that camera operators want. Producing award winning designs such as Vision, Vector, Osprey and Quattro, Vinten has an extensive knowledge of camera operator requirements. Working closely with camera operators, producers, directors and professional associations around the world, Vinten listens to their operational issues and build real solutions for them. Vinten designs and manufactures the very highest quality camera supports —able to withstand the most rigorous use and toughest conditions. All Vinten products are designed and manufactured in accordance with ISO 9001:2000. From fast-moving sports productions and dramatic ENG situations, to the slow and precise movements demanded in documentaries and drama - whatever the application, Vinten continues to develop a solution to meet the challenges and demands faced by producers and camera operators creating unique pictures for broadcast television, video and film. Vinten is also constantly striving to provide the most comprehensive worldwide customer support network. A global team of customer service professionals ensures that technical advice, training and service backup is always available.



PERFECT BALANCE SYSTEM



Compensating for the effect of gravity, Vinten's perfect balance makes the camera appear weightless in the hands of the cameraman. Vinten is the only manufacturer in the world to offer infinitely adjustable perfect balance.

Perfect balance means ...

The camera feels weightless at any tilt angle enabling you to capture the perfect shot with minimal effort. And, it's just as easy to move diagonally as it is to pan the camera. Work for

longer periods by reducing the physical strain of holding the camera in position. Zero maintenance and highly responsive.

Comparing Counterbalance Systems

As the camera tilts, the torque needed to counterbalance the camera increases. If the torque produced by the counterbalance system doesn't match the camera requirement exactly, it will either fall away or return to center, balancing only where the two lines cross.

This effect is most prominent with 'Linear' counterbalance systems as the tilt angle increases the effort required from the camera operator to stop it falling away or springing back increases. Frequently, camera operators rely on the drag system to dampen this 'out of balance' effect.

The patented Vinten Perfect Balance system offers infinite adjustment, providing precisely the right amount of torque necessary to counterbalance the camera throughout its range. No effort is required to move the camera, you can even go 'hands free'.

Vinten's infinite adjustment allows you to trim the counterbalance system so that exactly the right amount of torque is generated wherever the camera is positioned and because it balances perfectly, you use the ideal drag setting for shot framing, not to help balance the camera.

DRAG TECHNOLOGY



Vinten drag technology ensures precise framing at all times. Infinite adjustment allows you to select the level of drag you need and to work the way you want, rather than having to select from pre-determined levels as with stepped drag systems. Provides ultimate control with with continuous adjustment.

'Feel' your way to the drag setting that exactly suits you—no stepping, no compromises. Fast and repeatable set-up for perfect framing and control. Illuminated controls from Vision 11 upwards

Vinten drag systems provide a steep ramp at the start of the movement to ensure maximum control, particularly with slow framing adjustments that could be necessary with long tight shots and in difficult conditions. A shallower response curve is created as the speed of camera movement increases, enabling you to keep up with the shot as it develops.

Lubricated Friction - LF Drag

- ◆ Continuous drag adjustment; Controlled 'whip pan' movement
- ◆ Available on Vision 3, 6, 8, 11 and Vector 60, 70

Thin Film - TF Drag

In addition to the characteristics offered by the LF drag system, the patented TF drag system also offers...

- ◆ Increased range of drag from very light to exceptionally heavy
- ◆ A wide operating temperature range from -40°F to +140°F
- ◆ Outstanding 'whip pan' control
- ◆ Available on Vision 100, Vision 250 and Vector 700/450/900

PRO-6HDV & PRO-10

Protouch Range

Lightweight, high performance pan & tilt heads, the Pro-6HDV (up to 13.2 lbs.) and Pro-10 (up to 22 lbs.) are perfect for supporting the latest range of small professional DV camcorders in corporate, industrial and event videography. Designed to be simple to use the Pro-6 and Pro-10 incorporate easy to adjust drag knobs and are the ONLY heads in their class to include an illuminated leveling bubble for quick and convenient set up in low light situations. Continuously variable fluid drag ensures that they provide smooth movement and complete camera control.

Protouch systems combine either the Pro-6 or Pro-10 lightweight heads with the Vinten Pozi-loc tripod. The outstanding rigidity and positive action clamping system of the Pozi-Loc tripod makes it the preferred tripod for camera operators worldwide for professional control of much greater payloads. Pro-6DC and Pro-10DC system packages include a two-stage black aluminium pozi-loc tripod, floor spreader and soft case.



Pro-6HDV and Pro-10 Pan and Tilt Heads



The Pro-6HDV and Pro-10 are designed to support the latest professional DV/HDV camcorders weighing up to 13.2 and 22 lbs. (respectively). They embody fluid drag assemblies for pan and tilt motions with brakes on each axis to lock the head in any position. An illuminated levelling bubble is fitted to the rear of the head and a quick-release, side-loading adjustable slide plate is provided for camera mounting. A single fixed pan bar is supplied.

Pro-6 Head: 75mm ball base with one pan bar (Mfr # V4018-0001 • B&H # VIV40180001)**464.95**

Pro-10 Head: 75mm ball base with one pan bar (Mfr # 3809-3; B&H # VI38093).....**897.95**

Pan and Tilt Heads Specification

Model	Payload	Weight	Tilt Range	Counterbalance	Bowl Diameter
Pro-6HDV	13.2 lbs.	3.5 lbs.	+90/-60°	Fixed	75mm
Pro-10	22 lbs.	5.2 lbs.	+90/-60°	Fixed	75mm

Tripod Specification

Model	Payload	Weight	Material	Height	Folds to	Bowl Diameter
Pozi-Loc	55 lbs.	7 lbs.	Aluminum	61.5"	28"	75mm

Pro-6HDV and Pro-10 Tripods



Pro-6HDV System: Includes Pro-6HDV, 2-stage aluminum Pozi-Loc tripod, floor spreader, soft case (Mfr # PRO-6HDVF • B&H # VIPRO6HDVF)**999.95**

Pro-10 System: (Mfr # PRO10DC; B&H # VIPRO10DC): 2-stage aluminum Pozi-Loc tripod, floor spreader and soft case.....**1,499.95**

Protouch Accessories

Protouch Dolly (Mfr # U005-103; B&H # VIU005103): PD114 Dolly with cable guards.....**CALL**

Camera Mounting Plate (Mfr # 3808-900SP; B&H # VI3808900SP): For Pro-6. With one 1/4" screw, one 3/8" screw and locating pin.....**81.95**

Second Pan Bar (Mfr # 3219-104; B&H # VI3219104): For Pro-6 and Pro-10**154.50**

Camera Mounting Plate (Mfr # 3809-900SP; B&H # VI3809900SP): For Pro-10 with two 1/4" screws, one 3/8" screw and locating pin.....**81.95**

Soft Case (Mfr # U005-190; B&H # VIU005190): For Pro-6 and Pro-10 systems**159.95**

Protouch Flat Base to 75mm Bowl Adapter (Mfr # U005-153; B&H # VIU005153)**64.95**

Protouch Flat Base to 100mm Bowl Adapter (Mfr # U005-110; B&H # VIU005110)**114.95**

VISION PAN & TILT HEADS

RIGIDITY

Picture quality relies as much upon the rigidity of the camera support as it does on the smoothness of the pan & tilt head and the accuracy of the counterbalance. Vinten Pozi-Loc and the new Fibertec tripods have been designed to optimize rigidity without compromising operational essentials such as weight, reliability, maintenance and speed of set-up.

- ◆ Clearances in tripod design allow movement but are necessary for quick set-up and for the clamping system to work effectively. When the clamps are locked this clearance must be minimal so as to avoid unnecessary movement when framing, particularly on tight shots with long lenses.
- ◆ The use of drag forces a tripod to twist creating 'spring back' when the camera comes to rest, making precise shot framing and minor adjustments very difficult. The torsional rigidity of the tripod is the only thing that will minimize spring back.
- ◆ Vinten tripods combine minimal (Pozi-Loc) or "zero" clearance (Fibertec) with exceptional torsional rigidity, both are critical factors in providing the camera operator with ultimate control of the camera through every movement.

Why rigidity is important to your work:

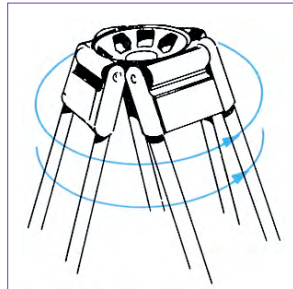

- ◆ The less movement in a support the better the drag system works and the smoother an on air move.
- ◆ The less rigid a support the more spring back at the end of a movement, thus changing the shot framing.
- ◆ The less rigid a support the more shake is evident in wind buffeting etc.

All degrade the quality and therefore the value of your work.

Vision 3

Designed for today's smaller, lighter video cameras, the Vision 3 fluid head weighs just 5 lbs. yet incorporates many of the key features you would usually expect to see only in larger, more expensive heads—and at a fraction of the price. Versatile and extremely responsive, the Vision 3 comes with an illuminated levelling bubble for quick and easy set-up, detented and calibrated drag controls using Vinten's Lubricate Friction (LF) system, plus a full $\pm 90^\circ$ of smooth tilt movement.



Perfect for all professional video applications, a unique interchangeable spring balancing system offers perfect balance for a wide range of payloads from 2.2 to 22 lb. So whatever your camera configuration, the Vision 3 head provides professional features without compromising any of the functionality you'd expect from the Vision range.

Vision 3 Fluid Head (Mfr # 35433 • B&H # V135433)**1079.95**

Vision 3 System: Including Vision 3 head, single-stage aluminum Pozi-Loc tripod, spreader, and soft case (Mfr # V3AP1 • B&H # VIVIN3AP1)**1799.95**

Vision 3 System: Includes Vision 3 head, two-stage aluminum Pozi-Loc tripod, spreader, and soft case (Mfr # V3AP2 • B&H # VIVIN3AP2)**1899.95**

Vision 3 System: Includes Vision 3 head, single-stage carbon fiber Pozi-Loc tripod, spreader, and soft case (Mfr # V3CP1 • B&H # VIVIN3CP1)**2299.95**

Vision 3 System: Includes Vision 3 head, two-stage carbon fiber Pozi-Loc tripod, spreader, and soft case (Mfr # V3CP2 • B&H # VIVIN3CP2)**2699.95**

Vision 6

Lightweight and compact, the Vision 6 fluid head is ideal for the professional lightweight, corporate and ENG user. Supporting the latest DV/HDV camcorders, Vision 6 provides a full $\pm 90^\circ$ of smooth tilt movement with a counterbalance range of 9.9 - 22 lbs. If you are constantly changing your camera set-up or you need that little bit of extra capacity, Vinten's unique infinitely adjustable perfect balance system lets you easily "set" just the right amount of counterbalance, so that your camera remains perfectly balanced, wherever it is positioned. Weighing just 5.3 lbs., the Vision 6 provides smooth shots, fast whip pan action and rapid set up. Comes with an illuminated levelling bubble for quick and easy set-up, detented and calibrated drag controls using Vinten's Lubricate Friction (LF) system.



Vision 6 Fluid Head (Mfr # 34493 • B&H # V134493)**1865.95**

Vision 6 System: Includes Vision 6 head, single-stage aluminum Pozi-Loc tripod, spreader, and soft case. (Mfr # V6AP1 • B&H # VIVIN6AP1)**2699.99**

Vision 6 System: Includes Vision 6 head, two-stage aluminum Pozi-Loc tripod, spreader, and soft case. (Mfr # V6AP2 • B&H # VIVIN6AP2)**2899.99**

Vision 6 System: Includes Vision 6 head, single-stage carbon fiber Pozi-Loc tripod, spreader, and soft case. (Mfr # V6CP1 • B&H # VIVIN6CP1)**3099.99**

Vision 6 System: Includes Vision 6 head, two-stage carbon fiber Pozi-Loc tripod, spreader, and soft case. (Mfr # V6CP2 • B&H # VIVIN6CP2)**3299.99**

Vision 6 System: Includes Vision 6 head, 2-stage carbon fiber Pozi-Loc tripod, Spreadloc, and soft case. (Mfr # V6CP2M • B&H # VIVIN6CP2M)**3949.95**

VISION SERIES PAN & TILT HEADS

Vision 8

Designed for the latest portable digital camera configurations used in professional broadcast, educational and corporate productions. An extensive camera capacity means greater flexibility in your work allowing you to use a wide variety of camera configurations on a light-weight head. Continuously Variable Perfect Balance system and LF (Lubricated Friction) Drag System combine to provide the perfect tool for capturing news, training or corporate communication, time after time. Weighing just 5.6 lbs. the Vision 8 provides smooth shots, fast whip pan action and rapid set-up. Comes with an illuminated levelling bubble for quick and easy set-up.



Vision 8 Fluid Head (Mfr # 3441-3 • B&H # VIV8LF).....**3199.95**

Vision 11

Perfect for all ENG and professional broadcast productions where larger batteries, small viewfinders and small LCD prompts are constantly swapped. With a capacity of 14.3 - 37.5 lbs., it supports an extensive range of digital camcorders in ENG configuration. Illuminated drag controls and counterbalance with digital readout ensures simple and repeatable "dial in" camera set-up, allowing for rapid deployment in any lighting situation. Also includes an illuminated levelling bubble. The Vision 11 system provides you with an extremely cost effective, all purpose camera control system that's equally at home on a documentary shoot or covering news.



Vision 11 Fluid Head (Mfr # 3442-3 • B&H # VIV11LFG).....**3974.95**



Vision 100

Defining the level of control excellence, the Vision 100 is perfect for all professional ENG or EFP situations that demand round the clock reliability. Ideal for today's digital camera configurations and one-piece camcorders, it incorporates the innovative TF drag system, allowing total control, precise movement, excellent camera control and consistent

performance in the toughest conditions. The drag knobs are backlit for easy viewing and detented to give a 'dial-in' feel. It offers perfect balance throughout its payload range and features an illuminated digital balance readout which provides repeatability for easier and quicker set-up. Following the action is effortless even at the heaviest drag setting, regardless of your environment, allowing you the freedom to work the way you choose. The Vision 100 is available in black and with the Fibertec tripod. This definitive system lets you frame and follow the action like never before, allowing you to widen your production boundaries. Exceptionally robust, this system gives you ultimate control of your camera and is the ideal companion for the professional who demands only the best.

Vision 100 Fluid Head (Mfr # 3466-3 • B&H # VIV100B).....**5072.95**



Vision 250

The standard in studio production as well as OB/EFP, the Vision 250 will support the latest portable cameras with viewfinders, prompts and pan bar controls. With a choice of easily changeable spherical or flat bases, it can be mounted on any pedestal or tripod, making it one of the most versatile products in the range.

The TF drag system allows you to select any level of adjustment, and because it works independently of the balance system, allows you to balance the pan and tilt axis so precisely that the effort needed to follow the action becomes totally insignificant. Provides constant drag and consistent performance over an extended temperature range from -40°C to +60°C. It also has the benefit of digital counterbalance readout, backlit drag controls and an illuminated level bubble, giving the camera operator the quickest and easiest set-up, particularly in low-light conditions. With its unique twin balancing mechanism, the Vision 250 can be easily adjusted to perfectly balance any camera and lens combination up to 72 lbs.

Vision 250 Fluid Head
(Mfr # 3465-3S • B&H # VIV250BB): Dual
100/150mm ball base**6952.50**

Vision 250 Fluid Head
(Mfr # 3465-3F • B&H # VIV250FB):
Quickfix/4-bolt flat base ..**7123.50**

	Vision 3	Vision 6	Vision 8	Vision 11	Vision 100	Vision 250
Maximum Payload	22 lb.	22 lb.	30.9 lb.	37.5 lb.	44.1 lb.	72.8 lb.
Counterbalance Range	2.2 - 22 lbs.*	9.9 - 22 lb.	12.1 - 30.9 lb.	14.3 - 37.5 lb.	15.4 - 44.1 lb.	22 - 72.8 lb.
Weight	5.1 lb.	5.3 lb.	6 lb.	6.2 lb.	7.1 lb.	13.5 lb.
Tilt Range	±90°	±90°	±90°	±90°	±90°	±90°
Ball Base	75mm	75mm	100mm	100mm	100mm	100/150mm
Leveling Bubble	Illuminated	Illuminated	Illuminated	Illuminated	Illuminated	Illuminated

* dependant on interchangeable spring

VISION SERIES PAN & TILT HEAD SYSTEMS

Vision 8 Systems

For portable cameras and one-piece camcorders in counterbalance range 12-31 lbs.

Vision 8 Tripod System (Mfr # V8AP1 • B&H # VIVIN8AP1)
Includes Vision 8 fluid head, single-stage aluminum Pozi-Loc tripod, spreader, and soft case.....**4293.95**

Vision 8 Tripod System (Mfr # V8AP2 • B&H # VIVIN8AP2)
Includes Vision 8 fluid head, two-stage aluminum Pozi-Loc tripod, spreader, and soft case.....**4574.95**

Vision 8 Tripod System (Mfr # V8CP1 • B&H # VIVIN8CP1)
Includes Vision 8 fluid head, single-stage carbon fiber Pozi-Loc tripod, spreader, and soft case.....**4588.95**

Vision 8 Tripod System (Mfr # V8CP2 • B&H # VIVIN8CP2)
Includes Vision 8 fluid head, two-stage carbon fiber Pozi-Loc tripod, spreader, and soft case.....**4499.95**

Vision 8 Tripod System (Mfr # V8CP2M • B&H # VIVIN8CP2M)
Includes Vision 8 fluid head, two-stage carbon fiber Pozi-Loc tripod, mid-level spreader, and soft case.....**4899.95**

Vision 11 Systems

For cameras and one-piece camcorders in ENG configuration in counterbalance range 14-37 lbs.

Vision 11 Tripod System (Mfr # V11AP2 • B&H # VIVIN11AP2)
Includes Vision 11 fluid head, two-stage aluminum Pozi-Loc tripod, spreader, and soft case.....**5354.95**

Vision 11 Tripod System (Mfr # V11CP2 • B&H # VIVIN11CP2)
Includes Vision 11 fluid head, two-stage carbon fiber Pozi-Loc tripod, spreader, and soft case.....**5663.50**

Vision 11 Tripod System (Mfr # V11CP2M • B&H # VIVIN11CP2M)
Includes Vision 11 fluid head, two-stage carbon fiber Pozi-Loc tripod, mid-level spreader, and soft case.....**6016.95**

Vision 11 Tripod System (Mfr # V11FT2 • B&H # VIVIN11FT2)
Includes Vision 11 fluid head, Fibertec two-stage carbon fiber tripod, spreader, and soft case.....**CALL**

Vision 11 Tripod System (Mfr # V11FT2M • B&H # VIVIN11FT2M)
Includes Vision 11 fluid head, Fibertec two-stage carbon fiber tripod, mid-level spreader, and soft case.....**CALL**

Vision 100 Systems

For camcorders in ENG & EFP configuration in counterbalance range 15-44 lbs.

Vision 100 Tripod System (Mfr # VB100AP2 • B&H # VIVB100AP2)
Includes Vision 100 fluid head, two-stage aluminum Pozi-Loc tripod, spreader, and soft case.....**6958.95**

Vision 100 Tripod System (Mfr # VB100CP2 • B&H # VIVIN100CP2)
Includes Vision 100 fluid head, two-stage carbon fiber Pozi-Loc tripod, spreader, and soft case.....**7017.95**

Vision 100 Tripod System (Mfr # VB100CP2M • B&H # VIVB100CP2M)
Includes Vision 100 fluid head, two-stage carbon fiber Pozi-Loc tripod, mid-level spreader, and soft case.....**6699.50**

Vision 100 Tripod System (Mfr # VB100AP2 • B&H # VIVB100AP2)
Includes Vision 100 fluid head, dual telescopic pan bars, two-stage aluminum Pozi-Loc tripod, and soft case.....**6598.95**

Vision 100 Tripod System (Mfr # VB100FT2 • B&H # VIVB100FT2)
Includes Vision 100 fluid head, Fibertec two-stage carbon fiber tripod, spreader, and soft case.....**7399.95**

Vision 100 Tripod System (Mfr # VB100FT2M • B&H # VIVB100FT2M)
Includes Vision 100 fluid head, Fibertec two-stage carbon fiber tripod, mid-level spreader, and soft case.....**7699.95**

Vision 250 Systems

For studio cameras and EFP configurations, e.g. larger lenses, viewfinders in counterbalance range 22-73 lbs.

Vision 250 Pro Tripod System (Mfr # VB250AP2 • B&H # VIVB250AP2)
Includes Vision 250 fluid head, dual telescopic pan bars with clamp, two-stage aluminum Pozi-Loc tripod, lightweight floor spreader, and soft case.....**9369.95**

Vision 250 Pro Tripod System (Mfr # VB250CP2 • B&H # VIVB250CP2)
Includes Vision 250 fluid head, dual telescopic pan bars with clamp, two-stage carbon fiber Pozi-Loc tripod, lightweight floor spreader, and soft case.....**9939.95**

Vision 250 Pro Tripod System (Mfr # VB250CP2M • B&H # VIVB250CP2M)
Includes Vision 250 fluid head, dual telescopic pan bars with clamp, two-stage carbon fiber Pozi-Loc tripod, Spread-Loc mid-level spreader, and soft case.....**10,259.95**

Vision 250 Pro Tripod System (Mfr # VB250AP2S • B&H # VIVB250AP2)
Includes Vision 250 fluid head, dual telescopic pan bars with clamp, two-stage aluminum Pozi-Loc tripod, and EFP/OB folding dolly with 5" wheels.....**9369.95**

VISION SERIES TRIPODS

With unrivalled height range capability, the lightweight, compact Vision tripods are quick and easy to set up and offer maximum stability and torsional stiffness. They are available in single- or two-stage with either aluminium or carbon fiber legs with 'Pozi-Loc' clamps. The Pozi-Loc cam-operated clamping system requires low effort with a 90° turn from on to off, providing you with a positive indication that the tripod is securely locked. The profile of the knob ensures that camera cables cannot snag. The 'Baby Legs' tripod is a low-level version, with a minimum height of 11" which makes even lower shots possible. An optional mid-level spreader is available.

Vision Aluminum ENG Tripods

Vision ENG tripods are precision-engineered with single or two-stage legs made of aluminum alloy.

- Single-Stage ENG Aluminum Pozi-Loc Tripod (75mm Bowl)**
Extends 25.5 to 57.3", weighs 6.2 lbs. supports 55 lbs, folds to 34"
(Mfr # 3775-3 • B&H # VI37753): Supports 55 lbs**628.95**
- Single-Stage ENG Aluminum Pozi-Loc Tripod (100mm Bowl)**
Same specs as above (Mfr # 3771-3 • B&H # VI37713)**632.95**
- Two-Stage ENG Aluminum Pozi-Loc Tripod (75mm Bowl)**
Extends 16.4 to 61.5", weighs 7 lbs. supports 55 lbs, folds to 28"
(Mfr # 3774-3 • B&H # VI37743): Supports 55.1 lbs.....**863.50**
- Two-Stage ENG Aluminum Pozi-Loc Tripod (100mm Bowl)**
Same specs as above (Mfr # 3770-3 • B&H # VI37703)**863.50**
- ENG Aluminum Pozi-Loc Baby Legs (75mm Bowl)**
Extends 9.3 to 20.1", weighs 4.6 lbs. supports 55 lbs, folds to 12.9"
(Mfr # 3779-3 • B&H # VI37793)**861.95**
- ENG Aluminum Pozi-Loc Baby Legs (100mm Bowl)**
Extends 9.3 to 20.1", weighs 4.6 lbs. supports 55 lbs, folds to 12.9"
(Mfr # 3778-3 • B&H # VI37783): Supports 55.1 lbs.....**861.95**

Vision Aluminum EFP Tripods

Vision Aluminum EFP Tripods are designed to be used for demanding ENG and EFP work where long lens shots require exceptional rigidity.

- Two-Stage EFP Aluminum Pozi-Loc Tripod (100mm Bowl)**
Extends 20.5 to 61.9", weighs 12.8 lbs. supports 99 lbs, folds to 30"
(Mfr # 3883-3 • B&H # VI38833)**1517.95**
- Two-Stage EFP Aluminum Pozi-Loc Tripod (150mm Bowl)**
Extends 20.5 to 61.9", weighs 12.8 lbs. supports 99 lbs, folds to 30"
(Mfr # 3880-3 • B&H # VI38803)**1674.50**
- EFP Aluminum Pozi-Loc Baby Legs (150mm Bowl)**
Extends 11 to 19.7", weighs 8.8 lbs. supports 99 lbs, folds to 14"
(Mfr # 3882-3 • B&H # VI38823)**1503.95**

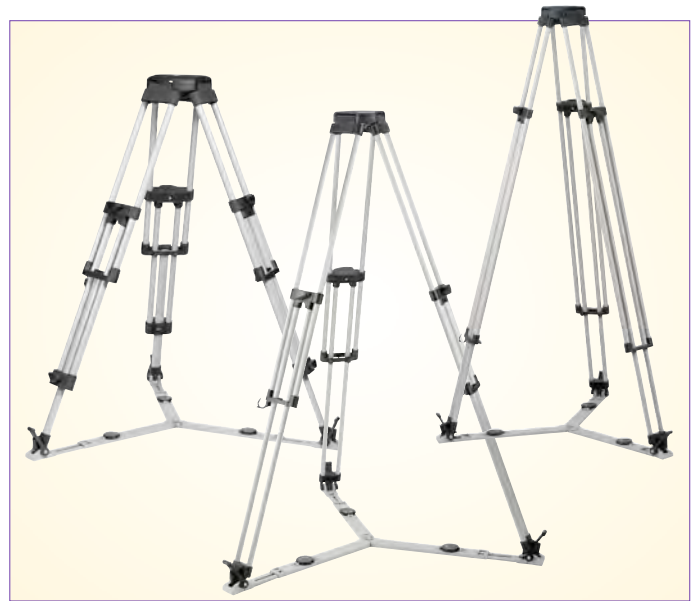

Vision Carbon Fiber ENG Tripods

The ultimate in lightweight tripods, these innovative ENG tripods are manufactured in an axially and spirally wound construction which adds more strength and rigidity to the tripod.

- Single-Stage ENG Carbon Fiber Pozi-Loc Tripod (75mm Bowl)**
Extends 25.5 to 57.3", weighs 5 lbs. supports 55 lbs, folds to 28"
(Mfr # 3777-3 • B&H # VI37773)**933.95**
- Two-Stage ENG Carbon Fiber Pozi-Loc Tripod (75mm Bowl)**
Extends 16.4 to 61.5", weighs 5.6 lbs. supports 55 lbs, folds to 28"
(Mfr # 3776-3 • B&H # VI37763)**1193.95**
- Single-Stage ENG Carbon Fiber Pozi-Loc Tripod (100mm Bowl)**
Extends 25.5 to 57.3", weighs 5 lbs. supports 55 lbs, folds to 28"
(Mfr # 3773-3 • B&H # VI37733)**959.95**
- Two-Stage ENG Carbon Fiber Pozi-Loc Tripod (100mm Bowl)**
Extends 16.4 to 61.5", weighs 5.6 lbs. supports 55 lbs, folds to 28"
(Mfr # 3772-3 • B&H # VI37723):**1214.95**

Vision Carbon Fiber EFP Tripods

These sturdy construction of these innovative EFP tripods provide an excellent platform when camera movement is critical. They are ideal for sport and location productions. The carbon fiber construction provides the ultimate in tripod rigidity, offering a 20% increase in torsional strength over the aluminum tripod. Load capacity up to 45 lbs.

- Two-Stage EFP Carbon Fiber Pozi-Loc Tripod (100mm Bowl)**
Extends 25.5 to 57.3", weighs 6.2 lbs. supports 55 lbs, folds to 34"
(Mfr # 3884-3 • B&H # VI38843)**2059.95**
- Two-Stage EFP Carbon Fiber Pozi-Loc Tripod (150mm Bowl)**
Extends 2.5 to 61.9", weighs 12 lbs. supports 99 lbs, folds to 28"
(Mfr # 3881-3 • B&H # VI38813)**2287.95**

VINTEN

SPREADERS

Your choice of spreader is determined by the conditions you work in. A ground spreader is by far the most stable device. However, it is ideally suited to flat, hard surfaces. A mid-level spreader is better for rough terrain or confined spaces, but it can be at the cost of picture stability. The Spread-Loc and floor spreaders are suitable for the full range of Vision single and two-stage tripods (excluding Baby-Legs with their own dedicated spreaders) and Fibertec.



Spread-Loc Mid-Level Spreader

Spread-Loc Mid-Level Spreader

The revolutionary Spread-Loc is a lightweight, fully adjustable, geared mid-level spreader, controlled by a single lock knob. This ensures fast and simple set up and infinitely adjustable positioning in all applications. Its revolutionary design incorporates a unique deployment system and a number of innovative safety features to prevent accidental damage to both spreader and tripod. The Spread-Loc easily achieves multi-level positioning or an incredibly small footprint so in the toughest terrain or the tightest of spaces you can be sure of reliable camera support that gives you great control. The arms are individually extendable to provide a large spreader radius and facilitate use on uneven ground. Easily installed on any tripod provided with Spread-Loc attachment points. Also compatible with 'Pozi-Loc' 75mm, 100mm and 150mm bowl tripod, as well as all 'Torque-Safe' ENG tripods.

Spread-Loc Mid-Level Spreader (Mfr # 37813 • B&H # V137813): Complete with set of three rubber feet **739.50**

Lightweight Floor Spreaders

Lightweight spreaders provide greater stability to Vision tripods. Their flexibility means that they can cope with uneven terrain and their hinged construction enables them to fold with the tripod. Quick-release straps ensure that they can be easily installed or removed if required.

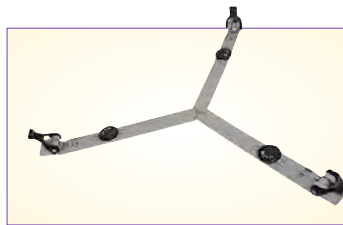

Gray Lightweight Floor Spreader (Mfr # 33133 • B&H # V133133) **384.95**

Black Lightweight Floor Spreader (Mfr # 33633 • B&H # V133633) **384.95**

Baby Legs Spreader (Mfr # 33793 • B&H # V133793) **323.50**

Heavy-Duty Floor Spreader

This spreader provides stability for heavy-duty tripods. Its flexibility means that it can cope with uneven terrain and the hinged construction enables it to fold with the tripod. Quick-release straps ensure that it can be easily installed or removed if required.

Heavy Duty Floor Flexible (Mfr # 33673 • B&H # V133673) **450.00**

Circular Anti-Skid Feet (Set of 3) (Mfr # 3378902SP • B&H # V13378902SP)

For times when it's not possible to use the dual spiked feet **102.95**

Vision ENG/EFP Dollies

Vinten's lightweight and compact ENG/EFP folding dollies are available in Studio and OB (mobile production) versions, with cable guards fitted to the castoring wheel units. Both also have fast action foot-operated brakes. In addition, the ENG Studio dolly is fitted with track locks to allow the use of tricycle steer mode, which gives the Osprey and Pro-Ped tripods the ability to operate on track. Vision Dollies fold for easy transportation and storage.



	ENG (Studio) V3955-0001	ENG (OB) V3955-0002	ENG (Small) V3955-0003	EFP (OB) 3497-3E	EFP (Studio) 3497-3G
Leg Radius	19.7"	19.7"	17.7"	20.7"	20.7"
Castor Diameter	3.9"	4.9"	4.9"	4.9"	4.9"
Skid Weight	12.8 lbs.	11.9 lbs.	11.7 lbs.	17 lbs.	20 lbs.
Cable Guards	YES	NO	NO	NO	YES
Track Locks	YES	NO	NO	NO	NO
Capacity	110.3 lb.	88.2 lbs.	110.3 lbs.	221 lbs.	221 lbs
Brakes	YES	YES	YES	YES	YES

STUDIO / OB PEDESTALS

Pedestals provide a number of advantages, but the real benefit of a balanced pedestal column is that it assists movement, enables precise camera elevation and avoids the effort and extra concentration needed to control an unbalanced camera, allowing the operator to pay full attention to shot framing. Perfect balance of the camera configuration is at the forefront of all Vinten innovations. Pro-Ped, Osprey and Quattro pedestals all utilize precisely engineered and patented systems, providing smooth, controllable camera balance. Studio noise levels are also a key consideration when selecting equipment, encouraging Vinten to develop new compositions that create far less disturbance than traditional materials. Vinten also use only the very best bearings and tracks, ensuring column elevation noise is minimal. Sound deadening materials are used to minimize noise further still. The Vinten range of pedestals offer the very best in camera control and freedom of movement to actively encourage creativity.



Vision Ped Plus Studio Pedestal (Mfr # V39510001 • B&H # VIV39510001)

The successor to the highly popular Vision Pedestal, with new and improved features including perfect balance, increased payload of 66 lbs. plus an integral manual pump and an inlet for use with an external supply. Weighing only 30 lbs., the Vision Ped Plus is the ideal solution for all-small production studios and corporate, educational, religious and government applications where simplicity of operation, portability and reliability is key. The pedestal is ideal for where professional framing and creative movement is essential and where lightweight prompter systems are required. In addition, there is a pressure gauge for clear and reliable set-up, a new detachable skid which improves overall stability significantly and a revised wheel braking system that ensures a smooth rolling base at all times**4433.95**

Pro-Ped Studio Pedestal (Mfr # 39833C • B&H # VI39833C)

An economical, lightweight pedestal, the Pro-Ped studio pedestal offers a two-stage system with a height range of 32". The lower stage column is balance-assisted to give easy elevation, while the upper stage offers perfect balance and 'on-shot' movement. The pneumatic counterbalance system employs a self-pumping action, making it easy-to-use on location. The dolly base is supplied with 5" wheels, track locks and cable guards.....**9259.95**

Pro-Ped OB Pedestal (Mfr # 3983-3B • B&H # VI39833B)

The Pro-Ped OB version is the same as the Studio version, except that it has 6" wheels, has a maximum height of 26.7", a minimum height of 58.9", and weighs 61.7"**9036.95**

Osprey Light Studio Pedestal (Mfr # V39500001 • B&H # VIV39500001)

Designed for the growing number of low budget studios that provide production facilities for niche channels and studios with live content. It is also suitable for mainstream studios requiring the quality of on shot movement that only a Vinten pedestal can provide. The Osprey Light is a 88 lbs. capacity pedestal, with a permanent full steering capability. This single stage pedestal also has a significantly improved wheel braking mechanism that eliminates the flat spots associated with traditional wheel brakes that can ruin a rolling shot. The pedestal is a great addition to those studios with limited budgets often requiring an extra pedestal but not wanting to limit capabilities and functionality**10,188.50**

Osprey Elite Studio Pedestal (Mfr # 3574-3C • B&H # VI35743C)

The 101lb. Osprey Elite supports the latest range of digital, portable and full facility cameras for studio production. The two-stage column offers 'on-shot' movement from a minimum height of 26" to a high of 56" with full crab and steer facilities controlled from a central steering ring. Its exceptional combination of lightness and structural integrity giving maximum stability while still allowing the column and dolly base to fold for easy transportation. The steering ring and kick ring are removable. Optional accessories include a portable hand pump to counterbalance the pneumatic system**19,217.50**

STUDIO / OB PEDESTALS

Osprey Elite OB Pedestal (Mfr # 3574-3B • B&H # VI35743B)

The same as the Studio version, but with a minimum height of 27", a maximum height of 57.3", and a wheel diameter of 6.3". It weighs 107.4 lbs **19,269.95**

Quartz One / Quartz Two Studio Pedestals

The versatile Quartz One is particularly suitable for news and studio productions. Its single-stage column supports a maximum payload of 209 lb. It incorporates a fully-skirted base with an innovative cable guard system, easily adjusted by three external knobs. The base offers maximum stability and rigidity, while the precise steering allows rapid repositioning, even in the tightest of sets. The light and sensitive feel of the column and crab steering controlled from a central steering ring enables fine and precise movements and a single foot brake gives that extra control at all times. Otherwise the same, the Quartz Two provides greater operational flexibility with its two-stage column, and has a 175 lb. capacity

Quartz One (Mfr # 3825-3 • B&H # VI38253) **CALL** **Quartz Two** (Mfr # 3826-3 • B&H # VI38263) **CALL**

Quattro-L Studio Pedestal (Mfr # V3852-0003 • B&H # VIV38520003)

Unique and innovative four-stage pedestal with an extensive range of benefits for today's camera operator. It provides an extensive height range capability and the opportunity to achieve creative lower angle shots. The four-stage column offerd maximum rigidity coupled with an unrivaled height range while minimizing torsional twist. Its triangular structure prevents any unwanted movement during operation. Revolutionary low-pressure pneumatic design ensures that it provides perfect balance throughout the 4-stages of elevation. Equipped with crab and steer, the highly-maneuverable studio base incorporates a unique cable guard jacking system. The pedestal can be charged simply by using an external hand pump **42,299.00**

Quattro-OBL OB Pedestal (Mfr # V4002-0002 • B&H # VIV40020002)

Same as the Quattro-L, but with a minimum height of 20", a maximum height of 59.4", a 7.8" wheel diameter. It weighs 255.8 lbs **40,454.95**

Quattro-SL Pedestal (Mfr # V3963-0002 • B&H # VIV39630002)

A compact pedestal designed for multi-camera studio locations, the Quattro-SL is perfect for restricted sets and smaller studios. (It easily tracks through any 30" set restriction.) As with all Quattro pedestals, the Quattro-SL offers a unique four-stage telescopic column, which allows exceptional minimal height. The unique triangular column design offers unrivalled torsional stiffness, minimizing all unwanted rotational movement. The low volume, low pressure pneumatic system combined with the new balance profile provides silky smooth, low effort elevation movement, allowing quiet and seamlessly developed shots. An optimized steering ring combined with low friction wheels allows confident tracking and reduced steering effort in any direction **34,199.00**



	Vision Ped Plus	Pro-Ped	Pro-Ped	Osprey Light	Osprey Elite	Osprey Elite	Quartz One	Quartz Two	Quattro -L	Quattro -OBL	Quattro -SL
Production	Studio	Studio	OB	Studio	Studio	OB	Studio/OB	Studio/OB	Studio/OB	Studio/OB	Studio/OB
Capacity	66 lbs.	121 lbs.	121 lbs.	88 lbs.	165 lbs.	165 lbs.	209.5 lbs.	176.4 lbs.	231.5 lbs.	231.5 lbs.	176.4 lbs.
Minimum Height	29.5"	26.2"	26.7"	30.1"	26"	27"	28"	26"	18.2"	20"	18.5"
Maximum Height	63"	58.4"	58.4"	51.4"	56"	57.3"	48"	56"	58.6"	59.4"	57.8"
Weight	33 lbs.	62.8 lbs.	62.8 lbs.	41.6 lbs.	101 lbs.	107.4 lbs.	180.8 lbs.	187.4 lbs.	348.8 lbs.	255.8 lbs.	300.6 lbs.
'On-Shot' Stroke	20"	16.1"	16.1"	21.2"	30.3"	30.3"	20"	30"	39.4"	39.4"	39.4"
Wheel Diameter	4"	5"	6"	4"	5"	6.3"	5"	5"	6.3"	7.8"	4.9"

STUDIO / OB PAN & TILT HEADS

Vector 70 & 700 provide up to 120° of perfectly balanced tilt range for digital studio and OB cameras with long lenses. The unique Vector counterbalance system is simple to adjust and requires no time-consuming cam changes when changing your configuration. The Vector 70H and 700H are also available for those using cameras with a high center of gravity.

Vector 70

The Vector 70 is a highly successful pan and tilt head using an entirely new, patented counterbalance mechanism. This is easily adjustable, with no time-consuming cam changes, to provide up to ±60° perfectly balanced tilt range for camera, lens and teleprompter combinations of up to 154 lb. It has a LF drag system, which is easily adjustable and provides smooth movement and consistent drag over a wide range of shots and whip pan. The Vector 70 has an integral soft-grip carrying handle, and a rear control pan and tilt brake. It is supplied with one telescopic pan bar and an auto-locking wedge adapter which will accept a standard camera wedge.



Vector 70 (Mfr # 3554-3 • B&H # V135543)**Call**

Vector 70H (Mfr # 3554-3H • B&H # V135543H)

For those using cameras with a high center of gravity.....**Call**

Vector 700

The Vector 700 contains a TF drag system providing a high level of control and exceptionally smooth movement. The TF drag system is a calibrated 'non-contacting' system ensuring constant drag and consistent performance over an extended temperature range from -40°C to +60°C. Using the patented Vector counterbalance mechanism, this head is easily adjustable, with no time-consuming cam changes, to provide up to ±60° perfectly balanced tilt range for camera, lens and teleprompter combinations of up to 154 lb. The Vector 700 is supplied with one telescopic pan bar and a wedge Adapter which will accept a standard camera wedge.



Vector 700 (Mfr # 34583 • B&H # V134583)**Call**

Vector 700H (Mfr # 34583H • B&H # V134583H)

For those using cameras with a high center of gravity.....**14,918.95**



Vector 90

The Vinten Vector 90 pan/tilt head supports oversized camera payloads up to 198.4 lbs. with perfect sinusoidal counterbalance. Once balanced, heavy cameras, such as the IMAX IW5A with a 2500' magazine, may controlled with the fingertips and move with fluid-like ease thanks, to the Lubricated Friction (LF) drag control system. True caliper disk brakes arrest movement during operation, and the center lock button firmly fixes the head in a horizontal position for safely mounting and dismounting camera payloads. Operation is assisted with the brightly illuminated rear-facing status LCD and bubble level, and dual pan arm rosettes allow left- or two-handed configurations.

Vector 90 (Mfr # V3998-0001 • B&H # VIV39980001)**10,574.95**

	Vector 70	Vector 90	Vector 450	Vector 700	Vector 950
Dimensions (HLW)	10 x 14 x 13.5"	9.8 x 8.9 x 13.5"	9.8 x 8.9 x 13.5"	10 x 14 x 13.5"	9.8 x 8.9 x 13.5"
Weight	38 lbs.	33 lbs.	33.1 lbs.	39.5 lbs.	33.1 lbs.
Tilt Range	±60° (70H: ±52°)	±90° (up to 99.2 lbs)	± 77° (± 90° @ 35kg)	±60° (70H: ±52°)	±90° (up to 132.2 lbs)
Capacity	154.4 lbs.	198.4 lbs.	99.2 lbs	154.4 lbs.	264.5 lbs.
Platform Adjustment	13"	+2.2 - 4.9"	+2.2 - 4.9"	13"	+2.2 - 4.9"
Pan Bar	Single Telescopic	Single Telescopic	Single Telescopic	Single Telescopic	Single Telescopic
Camera Fixing	Wedge Adapter	Wedge Adapter	Quick Release Plate	Wedge Adapter	Wedge Adapter
Levelling Bubble	Illuminated	Illuminated		Illuminated	
Base Fixing	4 bolt flat	4 bolt flat		4 bolt flat	

STUDIO / OB PAN & TILT HEADS

Vector heads have been synonymous with both studio and OB production world-wide for nearly a decade. The Vector 900 and 450 are designed for the new millennium and offer even more performance enhancements in one smaller package.

Vector 450

The Vector 450 is designed specifically for EFP applications, can cope with any camera payload from 22 lbs. through to 99.2 lbs., and offers perfect balance throughout its $\pm 90^\circ$ of tilt. This feature alone opens up all kinds of shots that have never been a simple option before. It covers all the area immediately below the operator's position or out as far as the lens allows. The typical configuration is supplied with a standard four bolt flat or spherical bases and an EFP Quickfit wedge adapter.



- Vector 450** (Mfr # 3805-3S • B&H # VI38053S): With 150mm bowl.....**CALL**
- Vector 450** (Mfr # 3805-3F • B&H # VI38053F): With flat base.....**CALL**

Vector 950

The Vector 950 comes complete with a standard four bolt base, single telescopic pan bar and wedge adapter. It offers a capacity of up to 264.5 lbs. and at this payload, provides $\pm 60^\circ$ of perfectly balanced tilt, allowing the safe control of today's long OB lenses. By combining the characteristics of the TF drag control with infinite perfect balance adjustment, the effort needed to control the effect of a heavy, moving camera payload remains constant and predictable, eliminating a major distraction. An LCD multifunction display offers a counterbalance readout, 24 hr. clock and stopwatch.



- Vector 950** (Mfr # V3996-0001 • B&H # VIV39960001).....**14,844.95**



HEAVY DUTY TRIPODS

Offering the most extensive height range available from heavy duty tripods on the market, the HDT has been totally re-designed, to offer increased torsional rigidity and robustness – ideal for large camera and lens combinations in any studio or OB application. The new pinned and glued telescopic leg design provides a wide range of height adjustment while offering superior strength and reliability. Set up has been made even simpler with the addition of engraved leg markings for rapid, even deployment and an integral level bubble allows for fine level adjustment. The new clamping system provides progressive feel to a positive stop which indicates when the leg is locked, ensuring simple and confident clamping.

Whatever the terrain, the HDT's three position swivel foot ensures a stable base. Choose from an increased length spike for soft surfaces, self-levelling pad for harder surfaces or a socket to fit all Vinten skids and floor spreaders. For more uneven surfaces, the newly designed mid-level spreader ensures the HDT is a convenient and stable option. The single piece, fixed length design offers exceptional strength and robustness, whilst simple to use and remove when necessary. With an integral carry handle providing comfortable and easy repositioning, this system is ideal for any terrain. Combined with the Vector range, these systems provide maximum control and flexibility wherever the next location may be.

- HDT-1** (Mfr # 39013 • B&H # VI39013): One-stage heavy-duty tripod. Supports up to 308 lb.....**2747.95**
- HDT-2** (Mfr # 39023 • B&H # VI39023): Two-stage heavy-duty tripod. Supports up to 265 lb.....**3863.50**

Heavy-duty dollies are available in Studio and OB versions, and are capable of supporting up to 350 lbs. Both have fast-action foot-operated brakes, while the Studio version is fitted with adjustable cable guards and track locks to provide tricycle steering.

- OB Skid for HDT-1 and HDT-2** (Mfr # 3497-3B • B&H # VI34973B).....**CALL**
- Studio Skid for HDT-1 and HDT-2** (Mfr # 3497-3C • B&H # VI34973C).....**1773.95**
- Soft Case for HDT-1 Tripod** (Mfr # 3535-3 • B&H # VI35353).....**418.50**
- Soft Case for HDT-2 Tripod** (Mfr # 3343-3 • B&H # VI33433).....**418.50**
- Tube for HDT-1 Tripod** (Mfr # 3411-3S • B&H # VI34113S).....**559.95**
- Tube for HDT-2 Tripod** (Mfr # 3411-3T • B&H # VI34113T).....**559.95**

ACCESSORIES & ADAPTERS

Vinten supply an extensive range of adapters. These include pan and tilt head to mounting adapters and camera to head adapters. Accessories include the Vinten portable pump and nitrogen charging adapter, both used for charging pedestals, and a variety of pan bars.

Extended Pan Bar Clamps

Extended Pan Bar Clamp for Vision

8 & 11 - Gray (Mfr # 3219-34 • B&H # VI321934) ..**35.95**

Extended Pan Bar Clamp for Vision 100 &

250 - Black (Mfr # 3219-105 • B&H # VI3219105) ..**362.95**

Vision 3 Balance Springs

Balance Spring #1 (Mfr # U005-161 • B&H # VIU005161)
Supports 2.2 lbs.....**44.95**

Balance Spring #2 (Mfr # U005-162 • B&H # VIU005162)
Supports 4.4 lbs.....**49.95**

Balance Spring #3 (Mfr # U005-163 • B&H # VIU005163)
Supports 6.6 lbs.....**48.95**

Balance Spring #4 (Mfr # U005-164 • B&H # VIU005164)
Supports 8.8 lbs.....**49.95**

Balance Spring #5 (Mfr # U005-165 • B&H # VIU005165)
Supports 11.0 lbs**48.95**

Balance Spring #6 (Mfr # U005-166 • B&H # VIU005166)
Supports 13.2 lbs.....**49.95**

Balance Spring #7 (Mfr # U005-167 • B&H # VIU005167)
Supports 15.4 lbs.....**44.95**

Balance Spring #8 (Mfr # U005-168 • B&H # VIU005168)
Supports 17.6 lbs**49.95**

Balance Spring #9 (Mfr # U005-169 • B&H # VIU005169)
Supports 19.8 lbs.....**48.95**

Balance Spring #10 (Mfr # U005-170 • B&H # VIU005170)
Supports 22.0 lbs**48.95**

Second Pan Bars

Pan Bar and Clamp (Mfr # 3219-78 • B&H # VI321978)
For Vision 3 and 6. Gray**159.95**

Telescopic Pan Bar and Clamp (Mfr # 3219-106 •
B&H # VI3219106); For Vision 3 and 6. Gray..**292.50**

Pan Bar and Clamp (Mfr # 3219-71 • B&H # VI321971)
For Vision 8. Gray.....**169.95**

**Telescopic Pan Bar
and Clamp** (Mfr # 3219-69 • B&H # VI321969); For
Vision 8 & 11. Gray**288.50**

**Telescopic Pan Bar
and Clamp** (Mfr # 3219-91 • B&H # VI321991); For
Vision 100 & 250. Black**292.95**

Camera Plates

Camera Mounting Plate

(Mfr # 3449-900SP • B&H # VI3449900SP): Complete
with two 3/8" screws and 1/4" pin Adapter. For
Vision 3 & 6.....**154.50**

1/4" Pin Adapter (Mfr # 3330-29 • B&H # VI333029):
Connects a camera with a 1/4" screw to a
standard Vision camera slide plate**34.95**

Camera Mounting Plate (Mfr # 3364-900SP; B&H #
VI3364900SP): Complete with two 3/8" screws.
For Vision 8, 11, 100 & 250.....**189.95**

Extended Camera Mounting Plate
(Mfr # 3330-33 • B&H # VI333033): Complete with two
3/8" screws. For Vision 8, 11, 100 & 250 ...**239.95**

Alternative Bases

150mm Leveling Bowl Adapter
(Mfr # 3330-17 • B&H # VI333017): With Quickfix ring
and 4-bolt flat base**274.50**

100mm Leveling Bowl Adapter
(Mfr # 3330-16 • B&H # VI333016): With Quickfix ring
and 4-bolt flat base**243.95**

75mm to 100mm Bowl Adapter
(Mfr # 3330-243 • B&H # VI3330243)**59.95**

4-Bolt Flat Base to 150mm Bowl Adapter
(Mfr # 3104-3 • B&H # VI31043)**399.95**

Ball Base for Vision 250 and HD250
(Mfr # 3525-900SP • B&H # VI3525900SP)**285.95**

Quickfix / 4-Bolt Flat Base
(Mfr # 3525-901SP • B&H # VI3525901SP):
For Vision 250 & HD250**276.95**

Quickfix Adapterss

**Quickfix Adapter
with 4-Bolt Flat Base** (Mfr # 3100-3 • B&H # VI31003):
For use with the Osprey, Pro-Ped, Quartz and
Quattro pedestals and heavy-duty tripods. It
has a load capacity of 100 lb.....**618.95**

**Quickfix Ring to fit
4-Bolt Flat Base Head** (Mfr # 3101-3 • B&H # VI31013):
Allows a four-hole flat-base pan and tilt head
to be installed on a heavy-duty tripod with a
Mitchell fixing. 220 lb. load capacity**167.50**

Quickfix Adapter with 150mm Ball Base
(Mfr # 3143-3 • B&H # VI31433): For use with a Vision
150mm bowl tripod. 100 lb. capacity.....**949.95**

Quickfix Adapter with 100mm Ball Base
(Mfr # 3144-3 • B&H # VI31443): For use with a Vision
100mm bowl tripod. 100 lb. capacity...**1259.95**

**Quickfix Levelling Adapter with
4-Hole Flat Base** (Mfr # 3328-30 • B&H # VI332830):
Allows a pan and tilt head with a Quickfix
base to be installed on a standard Vinten
four-hole base. The clamp and spherical
bearing allow the head to be levelled or
set at an angle. 100 lb. capacity**1142.95**

Heavy-Duty Quickfix Adapter (Mfr # 3490-3 •
B&H # VI34903): Allows a pan and tilt head with a
Quickfix base to be installed on an Osprey,
Pro-Ped, Quartz, Quattro, heavy-duty tripods
or any standard Vinten four-hole mounting.
Load capacity 220 lb.....**613.95**

Quickfix Wedges

**EFP Quickfit Automatic Adapter with
Wedge** (Mfr # 37613 • B&H # VI37613): Provides a
quick-release fixing for EFP cameras weighing
up to 100 lb. Recommended for HD250 and
Vector 450 fluid heads**678.95**

EFP Quickfit Wedge (Mfr # 376113 • B&H # VI376113):
With 2x 3/8" threaded screws. For EFP Quickfit
Automatic Adapter**144.50**

**EFP Quickfit Automatic Adapter
with Wedge** (Mfr # 3371-3 • B&H # VI33713)
Provides a quick-release fixing for EFP
cameras weighing up to 55.1 lb.
Recommended for Vision 6, 8, 11, 100 and 250
heads. Grey.....**339.50**

**EFP Quickfit Automatic Adapter
with Wedge** (Mfr # 3471-3 • B&H # VI34713)
Provides a quick-release fixing for EFP
cameras weighing up to 55.1 lb.
Recommended for Vision 6, 8, 11, 100 and 250
heads. Black.....**339.50**

ENG Quickfit Wedge (Mfr # 376311 • B&H # VI376311):
With 2x 3/8" threaded screws. For ENG Quickfit
Automatic Adapter**139.95**

STUDIO ACCESSORIES

Soft Carrying Cases

- Soft Case** (Mfr # 3334-3; B&H # VI33343): For Vision 3, 6, and 8 + single-stage tripod**209.95**
- Soft Case** (Mfr # 3358-3; B&H # VI33583): For Vision 3, 6, 8, 11 and 100 + two-stage tripod**267.95**
- Soft Case** (Mfr # 3339-3; B&H # VI33393): For Vision 8, 11 and 100 + single-stage tripod**456.50**



- Soft Case** (Mfr # 3340-3; B&H # VI33403): For Vision 3, 6, 8, 11 and 100 + two-stage tripod**404.95**
- Soft Case** (Mfr # 3341-3; B&H # VI33413) For Vision 100, and 250 + EFP tripod**506.95**
- Soft Case** (Mfr # 3440-202; B&H # VI3440202) For Vision ENG skid**251.95**
- Soft Case** (Mfr # 3532-3; B&H # VI35323) For Fibertec system**398.95**

Hard Carrying Cases

- Hard Transit Case** (Mfr # 3908-3; B&H # VI39083): For a Vision system tripod carried within a Vinten 3339-3 soft tripod case**594.95**
- Hard Case** (Mfr # 3909-3; B&H # VI39093): For a Vision system tripod carried within a Vinten 3340-3 soft tripod case**649.95**
- Hard Case** (Mfr # 3910-3; B&H # VI39103): For a Vision system tripod carried within a Vinten 3341-3 soft tripod case**736.95**
- Octagonal Thermoplastic Case** (Mfr # 4337-3; B&H # VI43373): For Vision 3 and 6 single-stage ENG tripod systems**453.50**
- Octagonal Thermoplastic Case** (Mfr # 4338-3; B&H # VI43383): For Vision 3, 6, 8, 11 and 100 two-stage ENG tripod systems**588.95**
- Octagonal Thermoplastic Case** (Mfr # 5338-3; B&H # VI53383): For Vision 250 two-stage EFP tripod systems**399.95**

Wheel Sets

- Osprey OB Wheel Set** (Mfr # 3329-30; B&H # VI3329-30): Set of three 6.3" wheels**2068.95**
- Osprey OB Wheel Cable Guards** (Mfr # 3329-44; B&H # VI332944): Set of three**537.50**
- Set of Soft Wheels for Quartz One and Quartz Two** (Mfr # 3429-904SP; B&H # VI3429904SP)**1666.50**
- Studio Wheel Set for Quattro-OB and OBL** (Mfr # 3446-910SP; B&H # VI3446910SP): Set of three 6.3" polycomposite wheels with cable guards**2919.95**

Steering Rings

- 25" Large Steering Ring** (Mfr # 3429-21; B&H # VI342921): For the Osprey Elite**363.50**
- 20.9" Small Steering Ring** (Mfr # 3374-17; B&H # VI337417): For Quartz**363.50**
- 23.2" Small Steering Ring** (Mfr # 3445-42; B&H # VI344542): For Quattro**616.95**
- 29.1" Large Steering Ring** (Mfr # 3445-43; B&H # VI344543): For Quattro-OBL**616.95**
- Tiller Bar for Osprey** (Mfr # 3329-21; B&H # VI3329-21)**CALL**

Charging

- Portable Manual Pump** (Mfr # 3357-3; B&H # VI33573): For Osprey, Osprey Light, Pro-Ped, Vision Ped Plus, Quartz & Quattro**844.95**
- Nitrogen Regulator** (Mfr # 10072; B&H # VI10072): Requires High Pressure Hose**739.95**
- High Pressure Hose** (Mfr # 1503-4; B&H # VI15034): For use with the Nitrogen Regulator to charge Vinten gas-charged pedestals**118.95**

Pan Bars

- Extra Short Pan Bar & Clamp** (Mfr # 3219-93; B&H # VI321993): For Vector 950, 700, 450 and 90. Black**226.95**
- Short Pan Bar & Clamp** (Mfr # 3219-94; B&H # VI321994): For Vector 950, 700, 450 and 90. Black**226.95**
- Telescopic Pan Bar & Clamp** (Mfr # 3219-82; B&H # VI321982): For Vector 950, 700, 450 and 90. Black**434.95**
- Foam Handle Sleeve** (Mfr # 3219-84; B&H # VI321984): Black**313.50**

Camera Mounting Systems

- Standard Wedge Plate** (Mfr # 3053-3; B&H # VI30533): For Vector 950, 700, 70 & 90**379.95**
- Short Wedge Plate** (Mfr # 3391-3; B&H # VI33913): For Vector 950, 700, 70 & 90**CALL**
- Wedge Extender** (Mfr # 3069-3; B&H # VI30693): For MK5 Head**2317.95**



Transit Flight Cases

- Hard Transit Case** (Mfr # 3907-3; B&H # VI39073): For Vector 450, 950 & 90 head**1209.95**
- Hard Transit Case** (Mfr # 3355-3; B&H # VI33553): For Vector 70 fluid head**1209.95**

Head Base Fixings

- Mitchell Adapter 4-Bolt Flat Base to Heavy Duty Tripod** (Mfr # 3103-3; B&H # VI31033)**569.95**
- Mitchell Spider with Wingnut** (Mfr # 3724-3; B&H # VI37243)**373.50**
- Mitchell Spider Adapter** (Mfr # 3055-3B; B&H # VI30553B): For pedestals. Black**426.95**
- Scaffold Clamp** (Mfr # 3407-1A; B&H # VI34071A): With 4-bolt fixing**1138.50**
- 8" Riser 4-Bolt Flat Base to 4-Bolt Flat Base** (Mfr # 3155-3; B&H # VI31553): Gray**488.50**
- 8" Riser 4-Bolt Flat Base to 4-Bolt Flat Base** (Mfr # 3155-3B; B&H # VI31553B): Black**488.50**
- 20mm Spacer Ring** (Mfr # 3354-900SP; B&H # VI3354900SP): For Vinten/Sachtler flange. 4-bolt flat base to 4-bolt flat base**179.95**
- Mitchell Base with Wingnut** (Mfr # 3750-3; B&H # VI37503)**508.50**
- Vector Balance Mechanism Retaining Strap** (Mfr # 3448-940SP; B&H # VI3448940SP)**43.95**
- Adapter Ring** (Mfr # 1212-7; B&H # VI12127): For Mitchell base with wingnut**219.95**
- Wingnut** (Mfr # 3432-201; B&H # VI3432201): For Mitchell Spider**124.95**