





The Professional Video SourceBook

Section 3

LENSES & ACCESSORIES

Canon	330-339
Fujinon	340-345
BeBob	346-347
Varizoom	348-353
16x9	354
Cinevate	355
LetusDirect	355
Cavision	356-357
Century Optics	358-364
Chrosziel.....	365-367
Petroff	368-370
Tiffen	371-381

Obtaining information and ordering from B&H is quick and easy. When you call us, just punch in the corresponding Quick Dial number anytime during our welcome message. The Quick Dial code then directs you to the specific professional sales associates in our order department.

 For Section 3, Lenses & Accessories
use Quick Dial #: 821

e-IFxs SERIES

2/3" SDTV Broadcast ENG/EFP Lenses

Since its introduction, e-IFxs technology has gained widespread acceptance from camera operators as an innovative digital tool capable of complimenting their most simple to advanced production needs. A full line of portable SD and HD lenses, e-Series, which stands for both "enhanced" Digital Drive control functions and "ecological" design allow operators to customize the digital control functions of their lenses with a high level of efficiency and precision. A key feature is their ultra-high-precision, microprocessor-driven digital servos with 16-bit optical encoders for zoom, focus and iris. This increases functionality with virtual reality studios as well as many other applications, and makes zoom and focus controls more precise and repeatable.



Enhanced Digital "e-Drive"

The e-IFsx (SD), e-HDxs (HD) and HDgc (IRSE models) lenses are equipped with Canon's Enhanced Digital "e-Drive", which provides servo control of iris, zoom and focus as well as automating other functions according to the user's particular needs. With e-Drive, users can easily program such functions as zoom and focus settings into the lens for precise, automated repeatability via an easy-to-use LCD menu, assignable "soft" function buttons and the rocker switch built into the lens grip. Users can program multiple settings or none at all, depending on their personal needs and preferences. The concept of enhanced "Digital Drive" is based on "Ease of Operation" for users.

- ◆ User settings for zoom and focus curve mode for precise control based upon the users requirement:
 - One of several operational curves can be chosen which will allow different zoom movement characteristics when operating the seesaw switch. This is accomplished as a linear adjustment as opposed to an adjustment done in steps.
 - "Zoom Track" allows the camera operator to adjust the electronic focal length to their desired range by memorizing zoom positions at both the tele and the wide side of the zoom.
- ◆ A precise movement mode can be memorized for the zoom seesaw control, zoom demand control and preset control.
- ◆ The drive unit can memorize 9 patterns of user-customized settings and also transmit the data between different drive units.
- ◆ Self-diagnostic mode provides error message if necessary.
- ◆ PC connection for remote control or lens condition check can be accomplished via a communication interface on the lens and personal computer with optional software.

Using digital technology, Canon Digital Drive provides the following three preset functions: Shuttle Shot, Framing Preset and Speed Preset.

Shuttle Shot: By memorizing any two focal lengths, the Digital Drive can automatically "shuttle" between the two points, moving in either direction.

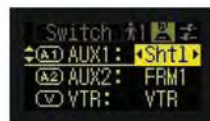

Framing Preset: An angle of view can be preset in either of two memories and the lens will zoom to that position by pushing a simple button. During a performance, framing preset will reproduce the zoom position decided upon at the rehearsal. It's easy to repeat the same zoom as often as you like at the highest speed or in a preset zoom speed.



Speed Preset: A specific zoom speed can be preset in memory and it is possible to repeat the zoom speed as often as you like by pushing a simple button.



e-IFxs SERIES

- ◆ AUX 1 and AUX 2 switches can be assigned for basic functions giving enhanced memory capability.
- ◆ Digitally assisted shooting techniques offered by e-Drive include graceful “padded” zoom start/stops so that zooms begin and end softly and without jerkiness. e-Drive provides for memorized focus and zoom positions, repeatable focus with no mechanical play or gear backlash; steady and slow zoom creeps; and one-button on/off.

Ergonomic Drive Unit

The e-IFxs/e-HDxs/HDgc (IRSE) Ergonomic Drive Unit is tilted at 12.5° to realize good balance and comfort. An informational display allows the user to customize the enhanced digital functions easily, precisely and fully. The enhanced digital functions are easily accessed and set via the Digital Function Selector, an X-Y axis switch located next to the display.

Compatibility with Virtual Studio

With 16-bit resolution Rotary Encoder Devices built into the enhanced digital drive unit, the lens can be easily integrated into a virtual digital studio system without any additions. The encoders enable superior precise control. The zoom servo provides a dynamic range of 0.5 sec. quick zooms to over a 5 min. super slow zoom. Repeatable focus and iris control are also much more precise. Canon’s unique technology has made the Encoder Device surprisingly small to be installed in the existing drive unit without changes in size or weight.

Demand Series to Support Digital Function

Canon offers a series of servo controllers for Digital Drive lenses. The ZSD-300D (zoom demand), FPD-400D (focus demand) and FPM-420D (focus servo module) to support the Digital Driver’s unique functions. These demands are connected to the “Digital Drive” via a 20-pin one-touch type connector, which makes the connecting and disconnecting easier and quicker. Also with the FPD-400D, focus servo operational curve can be selected unlike the conventional focus demand. The digital series of demands and the conventional demands have complete compatibility with each other, except for the unique digital functions.

Nomenclature of Canon Portable Lenses

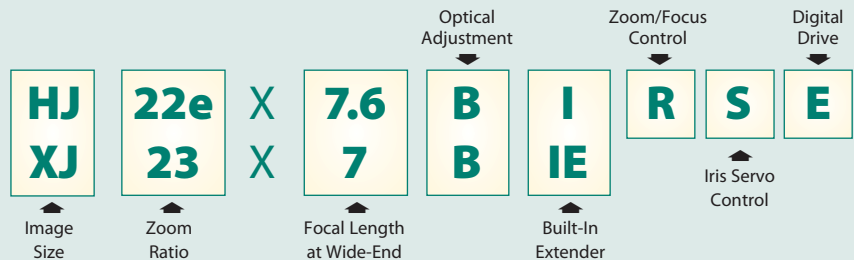

Image Size	HDTV		SDTV		
	Studio/Field	Portable Type	Studio/Field	Portable Type (ENG/EFP)	Portable Type (Pro-Video)
1"	HV, UV	HV, FV	FV	PV	—
2/3"	XJ, UJ	HJ, FJ, EJ, KJ	J, PJ	J	YJ
1/2"	—	KH	PH	H	YH

BUILT-IN EXTENDER

IE = Built-in Extender for Studio/Field Lenses
I = Built-in Extender for Portable Lenses
K = No Extender **V** = B.I. 0.8x Crossover

ZOOM/FOCUS CONTROL

R = Zoom: Servo; Focus: Manual
T = Zoom: Servo; Focus: Servo (f/remote control use)
A = Zoom: Servo; Focus: Servo Manual

X-Element and the Power Optical System

Research in special elements to minimize chromatic aberration led to an artificially recrystallized “Fluorite”, with extraordinary dispersion characteristics and the “Hi- UD” (high index ultra low dispersion) glass. Canon has succeeded in the practical use of special elements along with advanced design techniques like “separate achromatism”. Canon also developed an optical design technology known as the “Power Optical System” whose heart is the “X-Element”. By using the “X-Element” to its maximum power in the specially designed optical layout, higher specifications and quality can be achieved in smaller and lighter lenses. The lenses designed using the “Power Optical System” are known as the “XS-Series”.

Internal Focusing System

Canon was the first manufacturer to apply IF (Internal Focus) technology for use in high-quality broadcast ENG/EFP zoom lenses. The advantages include lower distortion, minimized chromatic aberration and strong protection from dust and condensation in a compact and lightweight package. Since those first IF lenses, Canon has developed a complete series of IF zoom lenses. The original IF technology evolved into the IF+ (plus) series and then into the IFxs series.

Crossover Technology

Switchable CCD cameras that can switch between the two aspect ratios are popular, since they allow the user to maintain both formats during transition. However, when the switch is made from 16:9 to 4:3, both sides of the image projected on the CCD are cut off, thereby shortening the diagonal of the picture from the conventional 4:3 norm of 11mm to 9mm. To compensate for this loss, Canon’s Crossover Technology is incorporated into a line of ENG (SDTV) and Studio/Field lenses that restore the 4:3 image of a switchable camera to that of a conventional 4:3 format camera. Crossover Technology utilized a built-in “Shrinker” which is a lens group to be inserted into the relay section of the master lens in order to shrink the image circle diameter by a factor of 0.8x.

J11ex4.5B (E-IFxs)

11x Ultra Wide-Angle Zoom Lens



The J11ex4.5B is the widest field of view portable lens offered by Canon to support high-performance analog NTSC and digital SDTV newsgathering and field production. It utilizes advanced optical technologies and powerful computer-aided design techniques to produce an exceptionally wide-angle SDTV lens in a modest 4.0 lb package. It is a design directly responding to the expressed creative desires of broadcasters and producers for a truly versatile mobile acquisition system. The J11ex4.5B represents a magnificent compromise between the demands for mobility in a handheld SDTV camera system (for ENG) and the exacting performance requirements for high-end SDTV production (EFP). The requisite optimization strategies to achieve this balance sought a high MTF over the entire image plane, minimization of chromatic aberrations, and maximization of image contrast. Preservation of the highest MTF at the wider angle focal lengths (where scene detail can be particularly high) was a special priority. The optional flexibility of Canon's Crossover aspect ratio switching system makes it a superb performer for both 16:9 widescreen and standard 4:3 image formats.

- ◆ The lens has an unprecedented maximum horizontal field of view of 88.7° (4:3 aspect ratio) and 93.7° for the 16:9 aspect ratio.
- ◆ Built-in 2x extender allows it to cover up to 100mm on the tele side, making it usable as a standard lens.
- ◆ Contrast is extended by superb control of black reproduction – with optical and mechanical design innovations that substantially reduced flare, veiling glare, and any internal reflections.
- ◆ Attention to minimization of ghost images and other highlight-related chromatic distortions caused by strong light sources on-axis and off-axis further extend the operational contrast range of the lens.
- ◆ Has a maximum relative aperture of f/1.8. Relative light distribution is optimized for f/2.8 and above and this uniformity of brightness across the image plane combines with the high contrast and excellent picture sharpness to produce vividly clear pictures.
- ◆ Tight control of critically important geometric distortion at wide-angle setting constituted another central design imperative.
- ◆ Besides reducing image ghost and flare, the included Vari-Polar Hood enables up to 90° rotation of filters attached to it. (A lever for rotation control is positioned under the hood). Makes it easy to control Polarizers, Cross filters, etc.

J11ex4.5B	NORMAL 4:3		16:9		SWITCHABLE 4:3		
Image Format	8.8 x 6.6mm; Ø 11mm		6.6 x 5.4mm; Ø 11mm		7.2 x 5.4mm; Ø 9mm		
Built-in extender	1.0X	2.0X	1.0X	2.0X	1.0X	1.2X	2.4X
Zoom Ratio	11X						
Range of Focal Length	4.5 – 50mm	9 – 100mm	4.5 – 50mm	9 – 100mm	3.7 – 41mm	4.5 – 50mm	9 – 100mm
Maximum Relative Aperture	1:1.8 at 4.5~36mm 1:2.35 at 50mm	1:3.6 at 9~72mm 1:4.7 at 100mm	1:1.8 at 4.5~36mm 1:2.35 at 50mm	1:3.6 at 9~72mm 1:4.7 at 100mm	1:1.8 at 3.7~38mm 1:1.95 at 41mm	1:1.8 at 4.5~36mm 1:2.35 at 50mm	1:3.6 at 9~72mm 1:4.7 at 100mm
Angular Field of View	88.7°x72.5' at 4.5mm 10.1°x7.6" at 50mm	52.1°x40.3' at 9mm 5.0°x7.6" at 100mm	93.7°x61.9' at 4.5mm 11.0°x6.2" at 50mm	56.1°x33.4' at 9mm 5.5°x3.1' at 100mm	88.7°x72.5' at 3.7mm 10.1°x7.6" at 41mm	77.3°x61.9' at 4.5mm 8.2°x6.2" at 50mm	43.6°x33.4' at 9mm 4.1°x3.1' at 100mm
Min. Object Distance	(M.O.D) 0.3m from front Lens Vortex						
Object Dimensions at M.O.D.	67.9x50.9cm at 4.5mm 5.9x4.4cm at 50mm	34.0x25.5cm at 9mm 3.0x2.2cm at 100mm	74.1x41.7cm at 9mm 6.4x3.6cm at 50mm	37.0x20.8cm at 9mm 3.2x1.8cm at 100mm	67.9x50.9cm at 3.7mm 5.9x4.4cm at 41mm	55.6x41.7cm at 4.5mm 4.8x3.6cm at 50mm	27.8x20.8cm at 9mm 2.4x1.8cm at 100mm
Size / Weight	168.2 (W) x 110.6 (H) x 237.7 (L) mm / 4.25 lbs.						

J11ex4.5B IRSE: Manual Focus, Servo Zoom and Iris
(Mfr # J11EX4.5B IRSE • B&H # CAJ11EX45BIZ).....**21,779.95**

J11ex4.5B VRSE: Same as above with built-in 16:9/4:3 Crossover
(Mfr # J11EX4.5B VRSE • B&H # CAJ11EX45BVR)**22,274.95**

J11ex4.5B WRSE: Same as above with built-in 2x Extender
(Mfr # J11EX4.5B WRSE • B&H # CAJ11EX45BWR)**26,279.95**

J11ex4.5B IASE: Servo/Manual Focus, Servo Zoom and Iris
(Mfr # J11EX4.5B IASE • B&H # CAJ11EX45BIQ).....**23,309.95**

J11ex4.5B VASE: Same as above with built-in 16:9/4:3 Crossover
(Mfr # J11EX4.5B VASE • B&H # CAJ11EX45BVA)**23,804.95**

J11ex4.5B WASE: Same as above with built-in 2x Extender
(Mfr # J11EX4.5B WASE • B&H # CAJ11EX45BWQ)**27,809.95**

J17ex7.7B • J22ex7.6B (e-IFxs)



Highest-Quality “Standard” and Advanced “Tele Portable” Lenses

The J17ex7.7B is designed for producers and broadcasters who require a generous range of focal lengths combined with a wide field of view in a lightweight mobile lens offering exceptional SDTV performance. Weighing only 3.3 lbs. the J17ex7.7B offers focal lengths up to 131mm (or 262mm with extender) and a wide field of view of 63.9° horizontal for the 16:9 aspect ratio. ENG/EFP performance advances to the next level with the J22ex7.6B lens.

The widest angle portable telephoto lens ever produced, the 4.2 lb. J22ex7.6B combines a 22x zoom range (7.6-168mm, or 15.2-336mm with 2x extender) and 7.6mm wide angle, with an amazing maximum zoom speed of 0.5 seconds from end to end. Both lenses include the Vari-Polar hood, enabling up to 90° rotation of filters attached to it.

J17ex 7.7B	NORMAL 4:3		16:9		SWITCHABLE 4:3		
Image Format	8.8 x 6.6mm; Ø 11mm		6.6 x 5.4mm; Ø 11mm		7.2 x 5.4mm; Ø 9mm		
Built-in extender	1.0X	2.0X	1.0X	2.0X	1.0X	1.2X	2.4X
Zoom Ratio	17X						
Range of Focal Length	7.7 – 131mm	15.4 – 262mm	7.7 – 131mm	15.4 – 262mm	6.4 – 109mm	7.7 – 131mm	15.4 – 262mm
Maximum Relative Aperture	1:1.8 at 7.7~105.5mm 1:2.3 at 131mm	1:3.6 at 4~205.0mm 1:4.6 at 262mm	1:1.8 at 7.7~105.5mm 1:2.3 at 131mm	1:3.6 at 154~205.0mm 1:4.6 at 262mm	1:1.8 at 6.4~103.3mm 1:1.9 at 109mm	1:1.8 at 7.7~102.5mm 1:2.3 at 131mm	1:3.6 at 154~205.0mm 1:4.6 at 262mm
Angular Field of View	59.9°x46.4' at 7.7mm 3.85°x2.89' at 131mm	31.9°x24.2' at 15.4mm 1.92°x1.44' at 262mm	63.9°x38.6' at 7.7mm 4.20°x2.36' at 131mm	34.6°x19.9' at 15.4mm 2.10°x1.18' at 262mm	59.5°x46.4' at 6.4mm 3.85°x2.89' at 109mm	50.1°x38.6' at 7.7mm 3.15°x2.36' at 131mm	26.3°x19.9' at 15.4mm 1.57°x1.18' at 262mm
Min. Object Distance	(M.O.D) 0.6m (10mm with Macro)						
Object Dimensions at M.O.D.	63.1x47.3cm at 7.7mm 3.8x2.9cm at 131mm	31.6x23.7cm at 15.4mm 1.9x1.5cm at 262mm	68.5x38.5cm at 7.7mm 4.2x2.4cm at 131mm	34.3x19.3cm at 15.4mm 2.1x1.2cm at 262mm	63.1x47.3cm at 6.4mm 3.8x2.9cm at 109mm	51.8x38.5cm at 7.7mm 3.1x2.4cm at 131mm	25.9x19.3cm at 15.4mm 1.6x1.2cm at 262mm

- J17ex7.7B IRSE** (Mfr # J17EX7.7B IRSE • B&H# CAJ17EX77BIR)
Manual Focus, Servo Zoom and Iris **12,779.95**
- J17ex7.7B VRSE** (Mfr # J17EX7.7B VRSE • B&H# CAJ17EX77BVR)
Same as above with built-in 16:9/4:3 crossover **13,274.95**
- J17ex7.7B WRSE** (Mfr # J17EX7.7B WRSE • B&H# CAJ17EX77BWR)
Same as above with built-in 2x extender **17,279.95**

- J17ex7.7B IASE** (Mfr # J17EX7.7B IASE • B&H# CAJ17EX77BIA)
Servo/Manual Focus, Servo Zoom and Iris **14,309.95**
- J17ex7.7B VASE** (Mfr # J17EX7.7B VASE • B&H# CAJ17EX77BVA)
Same as above with built-in 16:9/4:3 crossover **14,804.95**
- J17ex7.7B WASE** (Mfr # J17EX7.7B WASE • B&H# CAJ17EX77BWA)
Same as above with built-in 2x extender **18,809.95**

J22ex 7.6B	NORMAL 4:3		16:9		SWITCHABLE 4:3		
Built-in extender	1.0X	2.0X	1.0X	2.0X	1.0X	1.2X	2.4X
Zoom Ratio	22X						
Range of Focal Length	7.6 – 168mm	15.2 – 336mm	7.6 – 168mm	15.2 – 336mm	6.3 – 138.6mm	7.6 – 168mm	15.2 – 336mm
Maximum Relative Aperture	1:1.8 at 7.6~118.6mm 1:2.55 at 168mm	1:3.6 at 15.2~237.2mm 1:5.1 at 336mm	1:1.8 at 7.6~118.6mm 1:2.55 at 168mm	1:3.6 at 15.2~237.2mm 1:5.1 at 336mm	1:1.8 at 6.3~116mm 1:2.159 at 138.6mm	1:1.8 at 7.6~118.6mm 1:2.55 at 168mm	1:3.6 at 15.2~237.2mm 1:5.1 at 336mm
Angular Field of View	60.1°x46.9' 3.0°x2.3'	32.3°x24.5' 3.3°x1.1'	64.6°x39.1' 3.3°x1.8'	35.1°x20.1' 1.6°x0.9'	60.1°x46.9' 3.0°x2.3'	50.7°x39.1' 2.5°x1.8'	26.6°x20.1' 1.2°x0.9'
Min. Object Distance	(M.O.D) 0.8m (10mm with Macro)						
Object Dimensions at M.O.D.	87.4x65.6cm at 7.6mm 4.0x3.0cm at 168mm	43.7x32.8cm at 15.2mm 2.0x1.5cm at 336mm	95.0x53.4cm at 7.6mm 4.2x2.5cm at 168mm	47.5x26.7cm at 15.2mm 2.2x1.2cm at 336mm	87.4x65.6cm at 6.3mm 4.0x3.0cm at 138.6mm	71.8x53.9cm at 7.6mm 3.3x2.5cm at 168mm	35.9x26.9cm at 15.2mm 1.7x1.3cm at 336mm

- J22ex7.6B IRSE** (Mfr # J22EX7.6B IRSE • B&H# CAJ22EX76BIQ)
Manual Focus, Servo Zoom and Iris **22,319.95**
- J22ex7.6B VRSE** (Mfr # J22EX7.6B VRSE • B&H# CAJ22EX76BVQ)
Same as above with built-in 16:9/4:3 crossover **22,814.95**
- J22ex7.6B WRSE** (Mfr # J22EX7.6B WRSE • B&H# CAJ22EX76BWR)
Same as above with built-in 2x extender **26,819.95**

- J22ex7.6B IASE** (Mfr # J22EX7.6B IASE • B&H# CAJ22EX76BIA)
Servo/Manual Focus, Servo Zoom and Iris **23,849.95**
- J22ex7.6B VASE** (Mfr # J22EX7.6B VASE • B&H# CAJ22EX76BVZ)
Same as above with built-in 16:9/4:3 crossover **24,344.95**
- J22ex7.6B WASE** (Mfr # J22EX7.6B WASE • B&H# CAJ22EX76BWZ)
Same as above with built-in 2x extender **28,349.95**

J35ex11B • J35ex15B (e-IFxs)

35x Super Telephoto Lenses

The J35ex11B and the companion highly telephoto J35ex15B represent the pinnacle of Canon portable standard definition EFP lens design. These telephoto lenses are intended for producers and broadcasters engaged in documentary, natural history, and the many other challenging field productions that seek superb image capture in remote locations and from considerable distances. Aerial shooting, sports and entertainment coverage, portable acquisition in arduous terrain – are all superbly supported by these stalwart telephoto portable SDTV lenses.



- ◆ The J35x11B and the J35x15B bring entirely new shooting flexibilities to NTSC and SDTV field production. The J35x11B can extend to 770mm with the extender while the J35x15B can achieve an unprecedented 1050mm (with extender). Both lenses represent the very best in optical and mechanical design.
- ◆ High contrast is ensured by superb control of black reproduction – with optical and mechanical design innovations that substantially reduced flare, veiling glare, and any internal reflections. Similar attention to minimization of ghost images and other highlight-related chromatic distortions caused by strong light sources on-axis and off-axis further extend the operational contrast range of the lens.

- ◆ They represent an excellent marriage of needs for creative flexibility and mobility in a handheld system with the demanding performance requirements for high-end image acquisition at unusually long focal lengths. Novel dual lens approach broadens the shooting options, achieving adequate sensitivity, maximization of image contrast, and preservation of the highest MTF over the extended focal ranges.

J35ex11B-IASD: Built-in 16:9/4:3 crossover, 2x extender, image stabilizer (Mfr # J35EX11B IASD • B&H # CAJ35EX11BAS).....**42,335.95**

J35ex15B-IASD: Built-in 16:9/4:3 crossover, 2x extender, image stabilizer (Mfr # J35EX15B IASD • B&H # CAJ35EX15BAS).....**45,535.95**

Lens	J35ex 11B IASD				J35ex 15B IASD			
	NORMAL 4:3		16:9		NORMAL 4:3		16:9	
Built-in extender	1.0X	2.0X	1.0X	2.0X	1.0X	2.0X	1.0X	2.0X
Zoom Ratio	35X				33X			
Range of Focal Length	11 – 385mm	22 – 770mm	11 – 385mm	22 – 770mm	15 – 525mm	30 – 1050mm	15 – 525mm	30 – 1050mm
Maximum Relative Aperture	1:2.0 at 11~226.5mm 1:3.4 at 385mm	1:4.0 at 22~453mm 1:6.8 at 770mm	1:2.0 at 11~226.5mm 1:3.4 at 385mm	1:4.0 at 22~453mm 1:6.8 at 770mm	1:2.7 at 15~301.5mm 1:4.7 at 525mm	1:5.4 at 30~602mm 1:9.4 at 1050mm	1:2.7 at 15~301.5mm 1:4.7 at 525mm	1:5.4 at 30~602mm 1:9.4 at 1050mm
Angular Field of View	43.6°x33.4° at 11mm 1.31°x0.98° at 385mm	22.6°x17.1° at 22mm 0.65°x0.498° at 770mm	47.1°x27.6° at 11mm 1.43°x0.80° at 385mm	24.6°x14.0° at 22mm 0.71°x0.40° at 770mm	32.7°x24.8° at 15mm 0.96°x0.72° at 525mm	16.7°x12.6° at 30mm 0.48°x0.36° at 1050mm	35.5°x20.4° at 15mm 1.05°x0.59° at 525mm	18.2°x10.3° at 30mm 0.52°x0.29° at 1050mm
Min. Object Distance	(M.O.D) 2.2m (50mm with Macro)				(M.O.D) 2.2m (50mm with Macro)			
Object Dimensions at M.O.D.	161.9x121.4cm 4.7x3.5cm	81.0x61.0cm 5.2x1.8cm	176.8x99.5cm 5.1x2.9cm	88.4x49.8cm 2.6x1.5cm	118.3x88.7cm 3.5x2.6cm	59.2x44.4cm 1.8x4cm	129.2x72.7cm 3.8x2.1cm	64.6x36.4cm 1.9x1.1cm
Size / Weight	169.5 (W) x 143 (H) x 330 (L) mm / 9.9 lbs.				169.5 (W) x 143 (H) x 330 (L) mm / 9.9 lbs.			



IS-20BII Image Stabilizer

The IS-20BII is composed of two pieces of flat glass joined by a flexible bellows that can expand and contract as required. The space between the glass planes is filled with a special liquid, which exhibits a high refractive index. When the IS-20BII is placed between the subject and the optical system, the angle of the component can be changed according to the vibration angle related to the axis of light in the lens. This controls the angle of refraction of the light ray so that it reaches the image plane, free of shake. The IS-20BII covers a wide bandwidth which include high frequencies that are often encountered with moving vehicles, helicopters as well as other unsteady platforms and dramatically improves the video quality. The IS-20BII Image Stabilizer Adapter is designed to be front mounted on most of Canon's 2/3" ENG lenses. The full specifications of the lenses including the 2x extender can be used with the IS-20BII and the adapter does not cause any light loss. An additional 12v power supply is required.

IS-20B II Image Stabilizer for IFxs and HDxs lenses (Mfr # IS20BII17 • B&H # CAIS20B217).....**11,499.95**

e-HDxs SERIES

2/3" HDTV Broadcast ENG/EFM Lenses

Canon began developing lenses for the "HDTV System" more than 20 years ago. Canon was the first manufacturer to complete a standard series consisting of five basic models of practical 2/3" HDTV lenses by launching the HJ15x8B (in 1997) in addition to four existing lenses, Standard, Tele, Wide portable as well as Studio/Field. Canon continues to lead the broadcast industry in the 21st century "DTV" era with the next generation family of e-HDxs HDTV lens series. Same as the e-IFxs series, these lenses incorporate Canon's Digital e-Drive and have all the features listed on page 330.

SDTV vs. HDTV

Whereas one frame of the conventional SDTV (NTSC) system consists of 480 scanning lines, the number of scanning lines is more than 1.5 times that for the HDTV system. Furthermore the density of the scanning lines are even higher because the HDTV system has an aspect ratio of 16:9, which is wider and shorter in height than the normal SDTV (4:3 aspect ratio) system. The spatial frequency required for the HDTV system is about twice that required for SDTV. Overall, the resolution of the HDTV system is about twice that of the NTSC system and therefore, the lens requires much higher performance than the conventional lenses.

Sensitivity of the HDTV System

Two factors have to be considered to compare the sensitivity of the HDTV system with that of the conventional system. The first is that the HD camera has an aspect ratio of 16:9. This makes the sensitive area smaller and causes a 10% difference in sensitivity. The second is related to the HDTV system's depth of field, which is half of the conventional system. Therefore, on HD cameras, the lenses must be stopped down until their F-number becomes double in order to get the same depth of field as that in the conventional system. This reduces the sensitivity to one fourth (1/4).

Depth-of-Field for HDTV System

As HDTV has high resolution, even a small out-of-focus area can be detected. Since the radius of the permissible circle of confusion is about half that of the conventional system, the depth-of-field becomes proportionately smaller. Therefore, focusing has to be done with great care.

Aberration Correction for HDTV Lenses

The pixel size is about half in the HDTV system, and therefore the spread of a point image caused by a spherical aberration, coma, etc. should be diminished to about half. Even if the image is slightly out of focus, MTF is greatly influenced.

HJ11ex4.7B

11x Ultra Wide-Angle Zoom Lens

The widest portable HD zoom lens today, the HJ11ex4.7B features the optical excellence of Canon's e-HDxs technology for high-quality optics in a robust, compact and lightweight lens that weighs just 4.1 lbs. Enhanced Digital e-Drive further enhance the lens' versatility. With eDrive, users can easily pre-program functions such as zoom and focus settings into the lens for precise, automated repeatability via an easy-to-use LCD menu, assignable "soft" function buttons, and the rocker switch built into the lens grip. Program multiple setting or none at all depending on personal needs and preferences. The HJ11ex4.7B has a great focal range that goes from 4.7mm on the wide end all the way to 104mm with its built-in 2x extender. Zoom controls are built-in so you can use it in a hand-held configuration. Or if you're using it on a tripod you can connect an external zoom control to it.



HJ11ex4.7B-IRSE (Mfr # HJ11EX4.7B IRSE • B&H# CAHJ11EX47BIR)

e-HDxs 11 x 2/3" EFP High-Definition Ultra-Wide Angle Lens, with 2x extender, Manual Focus, Servo Zoom and Iris**24,899.95**

HJ11ex4.7B-ITS (Mfr # HJ11EX4.7B ITS-RE • B&H# CAHJ11EX47BI)

e-HDxs 11 x 2/3" High-Definition Remote Motor Drive Lens with 2x extender**31,229.95**

HJ17ex7.6B • HJ18ex28B (e-HDXs)

Standard and Super Telephoto Lenses

The HJ17ex7.6B has a focal length range from 7.6mm to 130mm (or 15.2mm to 260mm with 2x extender) and weighs in at just 3.5 lbs. It features a dynamic zoom speed range speed from 0.5 sec. to over 5 min. (from wide end to tele end). A switchable aspect ratio (16:9 and 4:3) version of the lens with Canon's "Crossover" option is also available.

A truly unique super telephoto portable high definition EFP lens, the HJ18ex28B is intended for producers and broadcasters who cover special events, concerts, documentaries, natural history, and many other challenging location productions that seek superb image capture over very long distances. Weighing in at only 5.5 lbs and an overall length of 10.5 inches, it offers the longest focal length of any lens in its class. And requires no mechanical support system to mount to the HD camera. Aerial shooting (using stabilized gimbals), sports and entertainment coverage, and portable HD acquisition in arduous terrain – are all superbly supported by this low-weight compact lens. The HJ18ex28B can extend to 500mm focal length (and to 1000mm with the extender). It has a very impressive optical speed of F2.8 up to a focal length of 286mm. High contrast is ensured by superb control of black reproduction – with optical and mechanical design innovations that substantially reduced flare, veiling glare, and any internal reflections. Similar attention to minimization of ghost images and other highlight-related chromatic distortions caused by strong light sources on-axis and off-axis further extend the operational contrast range of the lens.



HJ17ex 7.6B	16:9		SWITCHABLE 4:3		
Built-in extender	1.0X	2.0X	1.0X	1.2X	2.4X
Zoom Ratio	17X				
Range of Focal Length	7.6 – 130mm	15.2 – 260mm	6.3 – 107mm	7.6 – 130mm	15.2 – 260mm
Maximum Relative Aperture	1:1.8 at 7.6~97.5mm 1:2.4 at 130mm	1:3.6 at 15.2~2195mm 1:4.8 at 260mm	1:1.8 at 6.3~96.3mm 1:2.0 at 107mm	1:1.8 at 7.6~97.5mm 1:2.4 at 130mm	1:3.6 at 15.2~195mm 1:4.8 at 260mm
Angular Field of View	64.6°x39.1° at 7.6mm 4.20°x2.4° at 130mm	35.1°x20.1° at 15.2mm 2.10°x1.20° at 260mm	60.1°x46.9° at 6.3mm 3.90°x2.90° at 107mm	50.7°x39.1° at 7.6mm 3.20°x2.40° at 130mm	26.6°x20.1° at 15.2mm 1.60°x1.20° at 260mm
Min. Object Distance	(M.O.D) 0.56m (10mm with Macro)				
Object Dimensions at M.O.D.	65.4x36.8cm at 7.6mm 4x2.3cm at 130mm	32.7x18.4cm at 15.2mm 2.0x1.20cm at 260mm	59.9x44.9cm at 6.3mm 3.7x2.80cm at 107mm	49.1x36.8cm at 7.6mm 3.10x2.30cm at 130mm	24.6x18.4cm at 15.2mm 1.6x1.20cm at 260mm
Size / Weight	164 (W) x 106.5 (H) x 206.4 (L) mm / 3.7 lbs.				

HJ17ex7.6B-IRSE (Mfr # HJ17EX7.6B IRSE • B&H # CAHJ17EX76BI)
2x extender, built-in 16:9/4:3 crossover.....**17,459.95**

HJ17ex7.6B-WRSE (Mfr # HJ17EX7.6BWRSE • B&H # CAHJ17X76BWR)
Same as above with 2x extender.....**21,959.95**

HJ17ex7.6B-IASE (Mfr # HJ17EX7.6B IASE • B&H # CAHJ17EX76BQ)
2x extender, servo/manual focus, servo zoom and iris**18,989.95**

HJ17ex7.6B-VASE (Mfr # HJ17EX7.6B VASE • B&H # CAHJ17X76BVA): Built-in 16:9/4:3 crossover, servo/manual focus, servo zoom and iris.....**19,484.95**

HJ17ex7.6B-VRSE (Mfr # HJ17EX7.6B VRSE • B&H # CAHJ17X76BVR)
Built-in 16:9/4:3 crossover, manual focus, servo zoom and iris ..**17,954.95**

HJ17ex7.6B-WASE (Mfr # HJ17EX7.6B WASE • B&H # CAHJ17X76BWA)
Same as above with 2x extender.....**23,489.95**

HJ18ex 28B	NORMAL 4:3		16:9		SWITCHABLE 4:3	
Built-in extender	1.0X	2.0X	1.0X	2.0X	1.2X	2.4X
Zoom Ratio	18X					
Range of Focal Length	28 – 500mm	56 – 1000mm	28 – 500mm	56 – 1000mm	28 – 500mm	56 – 1000mm
Maximum Relative Aperture	1:2.8 at 28~286mm 1:4.9 at 500mm	1:5.6 at 58~572mm 1:9.8 at 1000mm	1:2.8 at 28~286mm 1:4.9 at 500mm	1:5.6 at 56~572mm 1:9.8 at 1000mm	1:2.8 at 28~286mm 1:4.9 at 500mm	1:5.6 at 56~572mm 1:9.8 at 1000mm
Angular Field of View	17.9°x13.4° at 28mm 1.00°x0.8° at 500mm	9.0°x6.7° at 58mm 0.50°x0.40° at 1000mm	19.5°x11.0° at 28mm 1.10°x0.60° at 500mm	9.8°x5.5° at 56mm 0.60°x0.30° at 1000mm	14.7°x40.1° at 28mm 0.80°x0.60° at 500mm	7.4°x5.5° at 56mm 0.40°x0.30° at 1000mm
Min. Object Distance	(M.O.D) 2.2m from front Lens Vortex					
Object Dimensions at M.O.D.	66.4x49.1cm at 28mm 3.80x2.90cm at 500mm	32.7x24.6cm at 56mm 1.90x1.50cm at 1000mm	71.1x40.0cm at 28mm 4.10x2.30cm at 500mm	35.6x20.0cm at 56mm 2.10x1.20cm at 1000mm	53.5x40.1cm at 28mm 3.10x2.30cm at 500mm	26.8x20.1cm at 9mm 1.60x1.20cm at 1000mm
Size / Weight	182.8 (W) x 123.7 (H) x 268.3 (L) mm / 5.47 lbs.					

HJ18ex28B-IASE: 2x Extender, Servo/Manual Focus, Servo Zoom and Iris (Mfr # HJ18EX28B IASE • B&H # CAHJ18EX28BI)**39,999.50**



HJ21ex7.5B • HJ22ex7.6B (e-HDXs)

Telephoto Lenses

The HJ21ex7.5B has the widest field of view among telephoto lenses. Optimized for the highest EFP performance, its relatively large input section includes optical compensation to reduce focus breathing to an extremely low level. Combining a 21x zoom range with generous wide-angle of 65.2° horizontal (for 16:9 aspect ratio) this 5.65 lb. lens is a superb workhorse that can address a wide range of field production projects. 3-group focusing system minimizes chromatic aberrations at wide-angle operation. Contrast is extended by superb control of black reproduction – with optical and mechanical design innovations that substantially reduced flare, veiling glare, and any internal reflections.

The HJ22ex7.6B is Canon's longest focal length portable HDTV lens without image stabilization. Mobilizing the best in portable EFP optical design criteria to achieve a remarkable lens offering focal lengths up to 168mm (or 336mm with extender) and a wide-angle of 64.6° horizontal (16:9 ratio). Combined with an exceptionally high sensitivity (F1.8 maximum aperture) this is a lens that can encompass an unusually broad range of shooting situations. Relative light distribution is optimized for F2.8 and above and this uniformity of brightness across the image plane combines with the high contrast and excellent picture sharpness to produce vividly clear HD pictures. Minimization of ghost images and other highlight-related chromatic distortions caused by strong light sources on-axis and off-axis further extend the operational contrast range of the lens.



HJ21ex 7.5B	16:9		SWITCHABLE 4:3		
Built-in extender	1.0X	2.0X	1.0X	1.2X	2.4X
Zoom Ratio	21X				
Range of Focal Length	7.5 – 158mm	15.0 – 316mm	6.2 – 130mm	7.5 – 158mm	15.0 – 316mm
Maximum Relative Aperture	1:1.9 at 7.5~116.0mm 1:2.6 at 158mm	1:3.8 at 15.0~232.0mm 1:5.2 at 316mm	1:1.9 at 6.2~116.0mm 1:2.15 at 130mm	1:1.9 at 7.5~116.0mm 1:2.6 at 158mm	1:3.8 at 15.6~232.0mm 1:5.2 at 316mm
Angular Field of View	65.2°x39.6° at 7.5mm 3.50°x2.00° at 158mm	35.5°x20.4° at 15.0mm 1.70°x1.00° at 316mm	60.8°x47.5° at 6.2mm 3.20°x2.40° at 130mm	51.3°x39.6° at 7.5mm 2.60°x2.00° at 158mm	27.0°x20.4° at 15.0mm 1.30°x1.00° at 316mm
Min. Object Distance	(M.O.D) 0.85m (10mm with Macro)				
Object Dimensions at M.O.D.	120.4x67.7cm at 7.5mm 5.60x3.20cm at 158mm	60.2x33.9cm at 15.0mm 2.80x1.60cm at 316mm	110.1x82.6cm at 6.2mm 5.10x3.80cm at 130mm	89.3x67.0cm at 7.5mm 4.20x3.20cm at 158mm	44.7x33.54cm at 15.0mm 2.10x1.60cm at 316mm
Size / Weight	179.9 (W) x 122.3 (H) x 260.1 (L) mm / 6.03 lbs.				

- HJ21ex7.5B-VRSE:** Built-in 16:9/4:3 crossover, manual focus, servo zoom and iris (Mfr # HJ21EX7.5B VRSE • B&H # CAHJ21X75BVR)**31,274.95**
- HJ21ex7.5B-WRSE:** Same as above with 2x extender (Mfr # HJ21EX7.5BWRSE • B&H # CAHJ21X75BWR)**35,279.95**
- HJ21ex7.5B-VASE:** Built-in 16:9/4:3 crossover, servo/manual focus, servo zoom and iris (Mfr # HJ21EX7.5B VASE • B&H # CAHJ21X75BVA).....**32,804.95**
- HJ21ex7.5B-WASE:** Same as above with 2x extender (Mfr # HJ21EX7.5BWASE • B&H # CAHJ21X75BWA)**36,809.95**

HJ22ex 7.6B	16:9		SWITCHABLE 4:3		
Built-in extender	1.0X	2.0X	1.0X	1.2X	2.4X
Zoom Ratio	22X				
Range of Focal Length	7.6 – 168mm	15.2 – 336mm	6.3 – 139mm	7.6 – 168mm	15.2 – 336mm
Maximum Relative Aperture	1:1.8 at 7.6~114.1mm 1:2.65 at 168mm	1:3.6 at 15.2~228.2mm 1:5.3 at 336mm	1:1.8 at 6.3~114.2mm 1:2.19 at 139mm	1:1.8 at 7.6~114.1mm 1:2.65 at 168mm	1:3.6 at 15.2~228.2mm 1:5.3 at 336mm
Angular Field of View	64.6°x39.1° at 7.6mm 3.27°x1.84° at 168mm	35.1°x20.1° at 15.2mm 1.64°x0.92° at 336mm	60.1°x45.9° at 6.3mm 3.00°x2.25° at 139mm	50.7°x39.1° at 7.6mm 2.46°x1.84° at 168mm	26.6°x20.1° at 15.2mm 1.22°x0.92° at 336mm
Min. Object Distance	(M.O.D) 0.85m (10mm with Macro)				
Object Dimensions at M.O.D.	100.6x56.6cm at 7.6mm 4.60x2.60cm at 188mm	50.3x28.4cm at 15.2mm 2.30x1.30cm at 336mm	60.1x69.4cm at 6.3mm 4.25x3.19cm at 139mm	75.8x56.6cm at 7.6mm 3.48x2.60cm at 168mm	37.9x28.4cm at 15.2mm 1.74x1.30cm at 336mm
Size / Weight	169.4 (W) x 111.9 (H) x 221.4 (L) mm / 4.27 lbs.				

- HJ22ex7.6B-IRS** (Mfr # HJ22EX76BIRS)
2x extender, 16:9/4:3 crossover**27,359.95**
- HJ22ex7.6B-IRAS** (Mfr # HJ22EX76BIAS)
2x extender, servo/manual focus, servo zoom and iris.....**28,719.95**
- HJ22ex7.6B-VRS** (Mfr # HJ22EX76BVRS)
Built-In 16:9/4:3 crossover, manual focus, servo zoom and iris.....**27,799.95**
- HJ22ex7.6B-WRS** (Mfr # HJ22EX76BWRS)
Same as above with 2x extender**31,359.95**
- HJ22ex7.6B-VAS** (Mfr # HJ22EX76BVAS): Built-in 16:9/4:3 crossover,
servo/manual focus, servo zoom and iris.....**29,159.95**
- HJ22ex7.6B-WAS** (Mfr # HJ22EX7.6B WAS)
Same as above with 2x extender**32,719.95**

HDgc SERIES

Concept of HDgc Series

The HDgc series was created to meet the demands of digital High Definition broadcasting and diversity of HDTV equipment. The HDgc series supports today's cost-effective HD acquisition systems. Adopting the advantages created by Canon's unique technology, the HDgc lenses exhibit high MTF, high resolution and high contrast from the center of the image to its extreme edges, meanwhile maintaining its compact size and weight.

The HDgc Series lenses are based upon Canon's latest design concepts which support the new generation of cost-effective HD acquisition systems. These lenses are designed to meet the specific bandwidth frequency (or the number of scanning lines) of the new HD camera systems and at the same time to offer an excellent performance-cost optimization.

All HDgc lenses feature a small drive unit that not only comfortably fits into the palm of the user's hand, but also improves the feeling of unity between the drive unit and the lens. These drive units, featuring a grip support and ribbed surface, are tilted at an ideal angle in order to achieve a better balance and to provide more comfort and help reduce operator fatigue. Like the e-IFxs and e-HDxs series lenses, the HDgc series incorporate Canon's Digital e-Drive and have all the features listed on page 330.



KH10ex3.6-IRSE

Compared to the SDTV Lenses, the HDgc Series Lenses are...

- ◆ Specially designed to use optical elements that are effective in further minimizing chromatic aberrations, such as "Hi UD Glass", "Aspherical Elements" and other special elements. These elements will decrease the flare that causes blurring of the picture and enables the lens to keep a high MTF.
- ◆ Setting a higher standard for parts quality and are designed to improve the lens structure. The HDgc lens manufacturing process has become tighter with reduced tolerance's to maintain a higher lens performance.

	SD		HDgc
Test Frequency of Broadcast Camera	320 TV Lines / 4MHz	up to 640 TV Lines / 8MHz	up to 800 TV Lines
Test Frequency of Broadcast Lens	24 Lines / mm	up to 48 Lines / mm	up to 74 Lines / mm
Actual Canon Resolution of Broadcast Lens	up to 75 Lines / mm		up to 100 Lines / mm

1/3" ENG/EPF Lens for JVC GY-HD100/110U

KT20x5B-KRS 20x 1/3" HDGC High Definition Lens
(Mfr # KT20X5B KRS • B&H # CAKT20X5BKRS)**8,819.95**

1/2" ENG/EPF Lenses for XDCAM

KH10ex3.6-IRSE: 10x Ultra W/A Lens with 2x Extender, Manual Focus, Servo Zoom and Iris (Mfr # KH10EX3.6 IRSE • B&H # CAKH10X36IRS)**22,949.95**

KH16x5.7-IRSE: 16x with 2x Extender, Manual Focus, Servo Zoom and Iris (Mfr # KH16EX5.7 IRSE • B&H # CAKH16X57IRS)**12,999.95**

KH21ex5.7-IRSE: 21x with 2x Extender, Manual Focus, Servo Zoom and Iris (Mfr # KH21EX5.7 IRSE • B&H # CAKH21X57IRS)**23,499.95**

KH13x4.5-KRS: 13x with Manual Focus, Servo Zoom and Iris (Mfr # KH13X4.5 KRS • B&H # CAKH13X45KRS)**11,519.95**

KH19x6.7-KAS: 19x with Sony Auto Focus, Servo Zoom and Iris
(Mfr # KH19X6.7 KAS • B&H # CAKH19X67KAS)**6,999.95**

KH20x6.4-KRS: 20x with Manual Focus, Servo Zoom and Iris
(Mfr # KH20X6.4 KRS • B&H # CAKH20X64KRS)**8,499.95**

2/3" ENG/EPF Lenses

KJ20x5.8KRS: 20x with Manual Focus, Servo Zoom and Iris
(Mfr # KJ20X5.8 KRS • B&H # CAKJ20X58KRS)**6,999.95**

2/3" Lenses for Panasonic P2 HD

KJ16ex7.7B-KRSD: 16x with Manual Focus, Servo Zoom and Iris
(Mfr # KJ16EX7.7B KRSD PS12 • B&H # CAKJ16EX77BK)**7,999.95**

KJ16ex7.7B-IRSD: 16x with 2x Extender, Manual Focus, Servo Zoom and Iris (Mfr # KJ16EX7.7B IRSD PS12 • B&H # CAKJ16EX77BI)**11,999.95**

HD-EC LENSES

High Definition Lenses for Digital Electronic Cinematography

Canon's HD-EC lenses offer the ability to deliver high quality HD content while lowering production costs. They allow flexibility such as the use of portable cameras in traditional situations, lighter weight ENG/EPV lenses to combat fatigue, and instant recall of past lens digital settings to ensure image consistency.

The best optical tools in electronic cinematography, HD-EC zoom lenses use Canon's Power Optical System featuring the "X-Element" —a unique high definition system that combines exceptional performance with enhanced specifications—to bring optical excellence to episodic TV, commercial and movie production. One of the remarkable features of Canon's HD-EC zoom lenses are the surprisingly small amount of focus breathing, making them ideal for HD-EC production. The HJ21 has up to 3x less focus breathing than any other comparable lens, and the HJ11 has an additional 50% less focus breathing. The spectacular HJ8x5.5B KLL-SC wide angle lens has diminished distortions and focus breathing to zero levels while maintaining the traditional film style feel of the picture. A maximum relative aperture of 2.1 makes all three lenses faster than ever and the best in the field.

Canon's HD-EC line also include six prime lenses. To provide the highest focusing accuracy possible, the six FJs prime lenses feature a focus rotation angle of 280°. Using proprietary design techniques, the lenses exhibit high MTF, high resolution, and high contrast from the center of the image to its extreme edges. The highest optical performance is achieved with consistent color balance across the series, and chromatic flares are brought to a zero level. Extremely helpful, the back focus of the lenses can be adjusted in a range of ±0.3mm, allowing for increased accuracy in all circumstances. Finally, they're designed with standardized front-of-lens diameter of 95mm, enabling the same matte boxes or filters to be used with all lenses.



FJ5

- ◆ All HD-EC lenses utilize Hi-UD (High Index, Ultra Low Dispersion) glass and Fluorite, to achieve lower aberrations, while exhibiting very high MTF.
- ◆ They have traditional film style feel and operation. Zoom (zoom lenses only), focus and iris indications are engraved with dual large luminous scales (focus distance marked in feet).
- ◆ Gear rings are compatible with studio focus rigs, manual fluid zoom drives and motorized control systems used for film lenses.
- ◆ From the ground up, uniform design concept achieves a desirable "Canon look" and consistent color temperature between lenses.
- ◆ Working distance between the camera and subject doesn't affect optical performance.
- ◆ Shortest M.O.D (Minimum Object Distance)

HD-EC Focal Length Comparison

Lens	2/3" HD-EC (11mm Diag.)	35mm Academy (27.26mm Diag.)	Super 16 (14.55mm Diag.)
FJ5	5mm	12.4mm	6.6mm
FJ9	9mm	22.3mm	11.9mm
FJ14	14mm	34.7mm	18.5mm
FJ24	24mm	59.5mm	31.7mm
FJ35	35mm	86.7mm	46.3mm
FJ55	55mm	136.3mm	72.8mm
HJ8x5.5B KLL-SC	5.5–44mm	13.6–109mm	7.3–58.2mm
HJ11x4.7B KLL-SC	4.7–52mm	11.6–128.9mm	6.2–68.8mm
HJ21x7.5B KLL-SC	7.5–157mm	18.6–391.6mm	9.9–209mm

HD Cine Prime lenses feature an 8-blade iris, and all lenses feature Internal Focus technology. The HJ21x features three group Internal Focus to improve optical performance at longer distances at high zoom ratios.

2/3" Prime Lenses for Digital Cinema Cameras

- FJ5 HD-EC 5mm Lens (Mfr # FJS5MM T1.7 • B&H # CAFJ55MM)**23,579.95**
- FJ9 HD-EC 9mm Lens (Mfr # FJS9MM T1.5 • B&H # CAFJ59MM)**18,089.95**
- FJ14 HD-EC 14mm Lens (Mfr # FJS14MM T1.5 • B&H # CAFJ514MM)**16,199.95**
- FJ24 HD-EC 24mm Lens (Mfr # FJS24MM T1.5 • B&H # CAFJ524MM)**15,999.95**
- FJ35 HD-EC 35mm Lens (Mfr # FJS35MM T1.5 • B&H # CAFJ535MM)**16,199.95**
- FJ55 HD-EC 55mm Lens (Mfr # FJS55MM T1.6 • B&H # CAFJ555MM)**18,089.95**

2/3" Wide Angle Cine Zoom Lenses

- HJ8x5.5B KLL-SC 8 x 2/3" Wide Angle Cine Zoom Lens (Mfr # HJ8X5.5B KLL-SC • B&H # CAHJ8X55BKLL)**23,399.95**
- HJ11x4.7B KLL-SC 11 x 2/3" Wide Angle Cine Zoom Lens (Mfr # HJ11X4.7B-II KLL-SC • B&H # CAHJ11X47BKL)**27,899.95**
- HJ21x7.5B KLL-SC 21 x 2/3" Cine Zoom Lens (Mfr # HJ21X7.5B-II KLL-SC • B&H # CAHJ21X75BKL)**31,859.95**

HA13x4.5 BRD • HA22x7.3BRD

13x and 22x High Definition Precision Focus Assist Lenses

Designed to improve the quality of HDTV image capture in field and studio applications, the HA13x4.5BRD HD wide-angle and HA22x7.3BRD HD EFP lens incorporate Precision Focus Assist, a built-in feature that addresses precise focus issues in HDTV production stemming from the format's shallow depth of focus and the lack of size and resolution in camera viewfinders.

Precision Focus Assist is not an auto focus system, but a focus assist that precisely adjusts the lens for optimum focus. Using this system, a selectable area of the video image is sampled as the focus point. The camera operator can adjust the user selectable point with a roller-ball type of controller, similar to a computer mouse, to position the focus point. The camera operator can then select manual or automatic focus assist. In the manual mode, there are three colored LED's that assist in achieving optimum focus. When the automatic mode is selected, the Precision Focus Assist system takes control and optimizes the focus, ensuring the captured image will be of the highest possible quality. Additionally, when panning and tilting, the operator can follow the focus point and position it above the object of focus as the camera is moved with the controller. An added benefit of the Precision Focus Assist is that it does not require tight zooming to focus. It performs even on a wide shot. Because smaller viewfinders on HD cameras lack high-quality resolution, operators often believe they've achieved focus when they haven't. And home viewers with 50" HD screens can easily see slight defocusing of the HDTV image. Remote controls were recently developed to allow video operators within view of a full-screen monitor to tweak the focus by referencing the large-screen monitor, but these systems have not been widely deployed. Precision Focus Assist system addresses HD focus issues that weren't answered with remote focus systems. This system essentially allows you to tweak the original focus and the confidence in the images you're sending out to air. You may not see the improvement in the viewfinder, but a video operator looking at the image on a 50" monitor will. This puts the role of focus back where it should be - in the hands of the camera operator.



HA13x4.5BRD 2/3" 13x Wide Angle High Definition Lens
(Mfr # HA13X4.5BRD • B&H # FUHA13X45BRD).....**34,334.95**

HA22x7.3BRD 2/3" 22x High Definition Lens
(Mfr # HA22X7.3BRD • B&H # FUHA22X73BRD).....**37,439.95**

	Focal Length	Zoom Ratio	Maximum Relative Aperture	Object Dimensions at M.O.D.	Filter Size	Size (Diameter x Length)	Weight
HA13x4.5BRD	4.5 to 59 mm	13x	1:1.8(4.5 ~ 39.2 mm) 1:2.9 (59 mm)	4.5mm 723 x 406mm 59mm 56 x 31mm	ø 127mm P=0.75	ø 95 x 238.5mm	1.88 kg
HA22x7.3BRD	7.3 to 161 mm	22x	1:1.9 (7.3 ~ 113mm) 1:2.7 (161mm)	7.3mm 1222 x 687mm 161mm 55 x 31mm	ø 107mm P=1.0	ø 110 x 287.3mm	3.0 kg

Fujinon's exclusive Precision Focus Assist is now in its 3rd generation and features improved focusing response, lower light loss, and reduced size. The PF system is the only focusing system that can maintain focus a any zoom position from the narrowest to the widest angle.

Contrast Focusing Method: It adopts a contrast method that utilizes differences in optical path length. It can instantly bring shooting objects into perfect focus without searching for focus and can follow moving objects smoothly in focus.

Focus Area Setting: When the PF lens is mounted on a camera, a focus area is shown on the viewfinder. The size and the position of the focus area can be changed at the camera operator's discretion. This function allows greater flexibility in the selection of the focus area depending on the type of production.

Reduce the Camera Operator's Burden: The PF assistance system constantly provides precise focusing when it is difficult to see whether the viewfinder image is in perfect focus. The operator can concentrate on framing the shot, knowing that the subject will be in perfect focus. It is especially effective when focusing is difficult, as when the camera is in a very low or a high position.

Can be Mounted on any 2/3" Camera: PF function is built into the lens and can be operational with the lens mounted on a 2/3" camera with no additional settings or optional devices. (On lens mounting, the focus area is initially fixed in the central area of the screen.)

Focus Mode Selection: The momentary mode provides for PF function only when pressing the button or the continuous mode may be selected for continuous PF function. These two modes of operation provide precise focusing according to the shooting situation, whether a still or moving image.

2/3" HDTV ENG/EFP LENSES

HDTV ENG style lenses for the 2/3" format are the mainstay in HDTV production and Fujinon offers the broadest range of lenses available. From the widest angle HA13x4.5, to the extreme telephoto HA42x13.5, there is a lens to cover every production application. The HA16x6.3BERM brings about a new era of lenses that combine both wide angle and a high magnification in one versatile package, while the HA25x11.5BERD and HA25x14.5BERD are the longest portable lenses available.

These lenses all incorporate Fujinon's DIGI POWER digital servo control system, offering advanced performance of its zoom lenses. In addition, the utilization of digital circuitry has made features available that were virtually impossible in the past. These lenses provide vastly improved accuracy and repeatability over previous designs and enable custom control parameters to be memorized for individual camera operator's preferences.



QuickZoom

QuickZoom speed is 0.7 seconds end to end. Quick Zoom provides for a rapid zoom movement to the telephoto position to check focus with the simple push of a button. Releasing the button returns the lens to the previously selected zoom position. Furthermore, by setting the switch, Quick Zoom can be performed remotely from zoom rate demand units.



QuickZoom

QuickZoom solves the problem of having to reframe a shot after checking focus. This exclusive feature is standard on all 2/3" HDTV lenses.

Utilizing the QuickZoom function can be an extremely time saving and productive production tool, by allowing a quick check if focus after a framed shot has been established. Simply press the Q • Z button and the lens zooms in tight at maximum speed, check focus and release the Q • Z button. The lens zooms out to the pre-selected shot automatically. No more guess work as to what the framed shot was prior to checking focus.

One Shot Preset

Zoom and focus can be preset and memorized in advance at a selected position. One touch of the switch during shooting will instantly return to the memorized position for time saving production.

Zoom Mode Select

A zoom mode switch provides the option to change the zoom response from "normal" to more sensitive on the wide or telephoto side. With the 3-zoom mode (10-zoom mode on ENG/EFP) the user can select the most suitable fine touch. These zooming mode settings are ideal when switching between productions such as drama and sports.

Zoom Limit

The zoom limit function can be used in the servo operation mode. By using this function, the zoom movement toward both the wide side and the telephoto side can be confined; therefore, zooming can be done within the desired shot angles. This enables cameramen to operate the zoom switch without any hesitations or worries about shooting unnecessary areas.

QuickFrame

QuickFrame system allows for quick manual framing of a shot without the need to select the manual operation. Adjusting the focus manually automatically disengages the servo, which is then automatically re-engaged, when the manual focus operation is stopped.

Auto-Cruising Zoom

Pressing the C-Z button while zooming will fix the zoom speed at the existing rate. Pressing the seesaw switch a second time slightly will return the zoom speed to normal.

Zoom Maximum Speed Adjustment

The maximum zooming speed obtained when pressing the seesaw switch to the end can be adjusted.

16-Bit Accuracy for Remote Control

Remote control of zoom, focus and iris is possible via 13-bit serial digital connection. Optional 16 bit processing is available for more accurate positioning in virtual studios and other applications.

Accessory Compatibility

Analog control accessories can be used with the DIGI POWER lens. (Some functions may be limited.)

2/3" HDTV ENG/EFP LENSES

HA13x4.5BERM/BERD

The HA13x4.5BERM/BERD offers the precise focusing and superior optical quality demanded for HD applications but with the durability and light-weight expected by professionals who regularly shoot in the field. The HA13x4.5BERM/BERD is a 2/3" format wide-angle lens with the widest angle in the market - 4.5mm with a 93.6° horizontal field of view. The BERM version has a 2x extender and manual focus servo zoom; while the BERD version also features a 2x extender, servo focus and servo zoom.

HA13x4.5ERM-M: 2x Extender, Manual Focus, Servo Zoom (Mfr # HA13X4.5ERM-M • B&H # FUHA13X45ERM)	25,899.95
HA13x4.5ERD-S: 2x Extender, Servo Focus and Servo Zoom (Mfr # HA13X4.5ERD-S • B&H # FUHA13X45ERD)	27,349.50
HA13x4.5DERM-M: 2x Extender, 4:3 Ratio Converter, Manual Focus, Servo Zoom (Mfr # HA13X4.5DERM-M • B&H # FUHA13X45DER)	29,999.95
HA13x4.5DERD-S: 2x Extender, 4:3 Ratio Converter, Servo Focus and Servo Zoom (Mfr # HA13X4.5DERD-S • B&H # FUHA13X45DEQ)	31,514.95

HA16x6.3BERM/BERD

Offering convenience, flexibility and versatility, this is the first lens to combine wide angle and high magnification (16x zoom ratio), enabling production crews to carry just one lens for a range of shooting environments. It is ideal for news, any handheld production, and in small studios for a broad range of applications. Delivering a lot of production power in a small package, the HA16x6.3BERM/BERD has a wide angle of 6.3mm and a telephoto focal length of 202mm with the 2x extender. The minimum focusing distance is 0.4 meters, and the lens includes Fujinon's exclusive DigiPower servo system for precise control of zoom functions. When used with HD/SD switchable cameras, the wide angle increases to 7.6mm in the 4:3 mode. This is the same as Fujinon's standard ENG/EFP lenses so no ratio converter or wide adapter is required. The BERM version has a 2x extender and manual focus servo zoom; while the BERD version also features a 2x extender, servo focus and servo zoom.

HA16x6.3ERM-M: 2x Extender, Manual Focus, Servo Zoom (Mfr # HA16X6.3ERM-M • B&H # FUHA16X63ERM)	20,354.95
HA16x6.3ERD-S: 2x Extender, Servo Focus and Servo Zoom (Mfr # HA16X6.3ERD-S • B&H # FUHA16X63ERD)	21,786.95

HA18x7.6BERM/BERD

With the longest focal length (137mm and 274mm with a 2x extender) and the widest angle of view (64.5° at 7.6mm) in its field, the HA18x7.6B is ideal for news and remote video production and designed to complement 2/3" HD video cameras. While it boasts a wide angle and high magnification it is still light and compact, making it ideal for handheld HD production. It features easily programmable digital features, allowing users to customize the lens to their preference. The HA18x7.6 features reduced chromatic aberrations, minimized flare and minimized focus breathing. Also offers Inner Focus, a servo module with Digi Power, QuickZoom, One Shot Pre-Set, Cruise Zoom, and RS-232 control ports. Zoom and focus can be preset and memorized in advance at a selected shot. One touch of the switch during shooting will instantly return to the memorized position. The maximum zoom speed can be selected in seven precise steps allowing the operator to fine-tune the zoom speed according to personal preferences.

HA18x7.6ERM-M : 2x Extender, Manual Focus, Servo Zoom (Mfr # HA18X7.6ERM-M • B&H # FUHA18X76ERM)	16,249.95
HA18x7.6ERD-S: 2x Extender, Servo Focus and Servo Zoom (Mfr # HA18X7.6ERD-S • B&H # FUHA18X76ERD)	17,534.95
HA18x7.6DERM-M: 2x Extender, 4:3 Ratio Converter, Manual Focus, Servo Zoom (Mfr # HA18X7.6DERM-M • B&H # FUHA18X76DER)	20,707.50
HA18x7.6DERD-S: 2x Extender, 4:3 Ratio Converter, Servo Focus and Servo Zoom (Mfr # HA18X7.6DERD-S • B&H # FUHA18X76DEQ)	31,514.95

	HA13x4.5BERM	HA16x6.3BERM	HA18x7.6BERM	HA22x7.3BERM	HA23x7.6BERM
Focal Length	(1X) 4.5 to 59 mm (2X) 9 to 119mm	(1X) 6.3 to 101 mm (2X) 12.6 to 202mm	(1X) 7.6 to 137 mm (2X) 15.2 to 274mm	(1X) 7.3 to 161 mm (2X) 14.6 to 322mm	(1X) 7.6 to 175 mm (2X) 15.2 to 350mm
Zoom Ratio / Extender	13X / 2X	16X / 2X	18X / 2X	22X / 2X	23X / 2X
Maximum Relative Aperture	1:1.8(4.5 ~ 39.2 mm) 1:2.6(59 mm)	1:1.8 (6.3 ~ 63 mm) 1:2.9 (101 mm)	1:1.8 (7.6 ~ 105 mm) 1:2.4 (137 mm)	1:1.9(7.3 ~ 113mm) 1:2.7 (161mm)	1:1.8(7.6 ~ 122mm) 1:2.65 (175mm)
M.O.D from Front of Lens	0.59m	0.6 m	0.84m	1.18m	1.07 m
Object Dimensions at M.O.D.	4.5, 750x422mm (Wide) 59, 55x31mm (Tele)	6.3 mm 712x 400mm 101 mm 45x 25mm	7.6 mm 738 x 415 mm 137 mm 41 x 23 mm	7.3 mm 1222x 687mm 161mm 55x 31mm	7.6 mm 909x 511mm 175mm 41x 23mm
Angular Field of View	4.5 mm 93° 38' x 61° 50' 59 mm 9° 18' x 5° 14'	6.3 mm 74° 33' x 46° 19' 101 mm 4° 00' x 3° 03'	7.6 mm 64° 30' x 39° 03' 137 mm 4° 01' x 2° 15'	7.3 mm 66°36' x 40°32' 161mm 3°25' x 1°55'	7.6 mm 64°30' x 39°03' 175mm 3°08' x 1°46'
Filter Size	ø 127 mm P=0.75	ø 107 mm P=1	ø 82 mm P=0.75	ø 107 mm P=1.0	ø 95 mm P=1.0
Weight (w/o hood)	1.98 kg	1.98 kg	1.58 g	3.15 kg	1.85 kg

2/3" HDTV ENG/EFP LENSES

HA22x7.8BERM/BERD and HA22x7.3ERM/ERD

The HA22x7.8B is a telephoto lens with a 2x extender, making it the longest such lens in the market with a compact size and weight (under 4 lbs.), maximum relative aperture of F1.8 (from 7.8-122mm) and reduced MOD of 0.8.

Ideal for professionals that require pristine images, the HA22x7.3 offers the most comprehensive angular field of view in its class. With its reduced focus breathing, a flexible F-stop range (up to 1.9) and the exclusive DigiPower servo system for fast and accurate zooming, its the perfect complement for TV commercials and remote location documentary work. With a 7.3-161mm (1x) and 14.6-322mm (2x) focal length, 22x zoom ratio, standard macro, widescreen (16:9) inner focus, QuickZoom functionality and weighing under 7 lbs., the HA22x7.3 offers the flexibility and durability necessary for demanding, daily 16:9/4:3 production under the harshest of conditions.

HA22x7.8ERM-M : 2x Extender, Manual Focus, Servo Zoom (Mfr # HA22X7.8ERM-M • B&H # FUHA22X78ERM).....	27,629.95	HA22x7.3ERM-M : 2x Extender, Manual Focus, Servo Zoom (Mfr # HA22X7.3ERM-M • B&H # FUHA22X73ERM).....	28,775.95
HA22x7.8ERD-S : 2x Extender, Servo Focus and Servo Zoom (Mfr # HA22X7.8ERD-S • B&H # FUHA22X78ERD).....	29,062.50	HA22x7.3ERD-S : 2x Extender, Servo Focus and Servo Zoom (Mfr # HA22X7.3ERD-S • B&H # FUHA22X73ERD).....	30,206.95
HA22x7.8DERM-M : 2x Extender, 4:3 Ratio Converter, Manual Focus, Servo Zoom (Mfr # HA22X7.8DERM-M • B&H # FUHA22X78DER).....	32,045.95	HA22x7.3DERM-M : 2x Extender, 4:3 Ratio Converter, Manual Focus, Servo Zoom (Mfr # HA22X7.3DERM-M • B&H # FUHA22X73DER).....	33,189.95
HA22x7.8DERD-S : 2x Extender, 4:3 Ratio Converter, Servo Focus and Servo Zoom (Mfr # HA22X7.8DERD-S • B&H # FUHA22X78DEQ).....	33,476.95	HA22x7.3DERD-S : 2x Extender, 4:3 Ratio Converter, Servo Focus and Servo Zoom (Mfr # HA22X7.3DERD-S • B&H # FUHA22X73DEQ).....	34,619.95

TS-P58A Optical Stabilizer

Providing an anti-vibration range of up to 20% of picture height, the TS-P58A utilizes Fujinon's renowned OS-TECH image stabilization technology to deliver steady shots and keep after-shaking to a minimum when shooting with high-magnification lenses. Designed for Fujinon's full range of SD and HD telephoto lenses, the TS-P58A utilizes eliminates unwanted vibration and image shifting caused by even the most subtle motion, such as an operator's heartbeat or slight support-platform movements. It employs an optical shift system with a vibration detection sensor that compensates for shifting light rays that occur when an image vibrates. Its image stabilization ability immediately improves the quality of extreme close-ups taken during windy or otherwise unstable conditions.

The TS-P58A increases lens magnification by 1.25x, making extreme close-up shots possible with shorter-focal-length lenses. This capability opens up new applications for the add-on stabilizer. It fits "sandwich-style" between the camera and lens. The anti-vibration function can be activated from the control-setting switch near the operator's hand. It can provide image compensation both vertically and horizontally. Weighs under 2 lbs. and is adaptable to all Fujinon ENG-style 2/3" B-type bayonet mount lenses.



TS-P58A OS-Tech Optical Stabilizer For 2/3" Lenses (Mfr# TS-P58A • B&H# FUTSP58A)..... **16,999.95**

HA25x11.5BERD and HA25x16.5BERD

Lightweight, with HD ENG-Style lens' telephoto capability, the HA25X11.5BERD and HA25x16.5BERD offer the ability to capture quality high definition images from previously unreachable, remote locations. Weighing a mere 6.2 /6.3 pounds, the lenses need no additional support. They are compact telephoto lenses ideally suited for gyro stabilized platforms in aircraft, wildlife photography in remote areas and HD surveillance applications, where light weight and unobtrusive appearance are critical.

With a maximum focal length of 826mm (2x) for the HA25x16.5, reduced focus breathing, an F-stop range of 2.8 to 4.0 (HA5x16.5) and 2.0 to 2.8 (HA25X11.5) and Fujinon's exclusive DigiPower servo system for fast and accurate zooming, the HA25x lenses are the perfect complement for remote control systems and location documentary work. They also provide widescreen 16:9 or traditional 4:3 production capability under the harshest field conditions. Standard features on the HA25X11.5BERD and HA25x16.5BERD include Fujinon's Digi Power zoom and focus servo, 2x range extender and direct RS232 control.

HA25x11ERD-S : 2x Extender, Servo Focus, Servo Zoom (Mfr # HA25X11.5ERD-S • B&H # FUHA25X115ER).....	40,709.95	HA25x16.5ERD-S : 2x Extender, Servo Focus, Servo Zoom (Mfr # HA25X16.5ERD-S • B&H # FUHA25X165ER).....	42,918.95
HA25x11ERD-F18 : Same as above with motor driven 2x (Mfr # HA25X11.5ERD-F18 • B&H # FUHA25X115RD).....	42,714.95	HA25x16.5ERD-F18 : Same as above with motor driven 2x (Mfr # HA25X16.5ERD-F18 • B&H # FUHA25X165RD).....	44,921.95

2/3" SDTV BROADCAST ENG/EFP LENSES

While standard definition is slowly being phased out in favor of the newer high definition formats, there are still many applications that require high quality SD (Standard Definition) TV lenses. All Fujinon Broadcast series lenses feature the optimum in optical quality and rugged, reliable design. Almost identical to their HDTV counterparts (except without the HD glass), these lenses feature DIGI POWER, QuickZoom, One-Shot Preset, Zoom Mode Select, Zoom Limit, Auto-Cruising Zoom, QuickFrame and maximum adjustable zoom speed. They are also all compatible with the TS-P58A optical stabilizer (previous page). However, unlike their specific HD counterparts, the A42x9.7BERD and A42x13.5BERD do not incorporate Fujinon's built-in OS-Tech image stabilization system.



	A13x4.5BERM	A18x7.6BERM	A22x7.8BERM	A42x9.7BERD	A42x13.5BERD
Focal Length	(1X) 4.5 to 59 mm (2X) 9 to 118mm	(1X) 7.6 to 137 mm (2X) 15.2 to 274 mm	(1X) 7.8 to 172 mm (2X) 15.6 to 344 mm	(1X) 9.7 to 410 mm (2X) 19.4 to 820mm	(1X) 13.5 to 570 mm (2X) 27 to 1140 mm
Zoom Ratio	13X	18X	22X	42X	42X
Maximum Relative Aperture	F1.8 (to 41mm) F2.6 (at 59mm)	F1.8 (to 103 mm) F2.4 (at 137 mm)	F1.8 (to 124 mm) F2.5 (at 172 mm)	F2.0 (to 219 mm) F3.7 (at 410 mm)	F2.8 (to 305 mm) F5.2 (at 570 mm)
M.O.D from Front of Lens	0.3 m	0.6 m	0.8 m	2.8 m	5.2m
Object Dimensions at M.O.D.	4.5, 663x497mm(at Wide) 59, 51x38mm (at Tele)	7.6 mm 677 x 508 mm 137 mm 38 x 28 mm	7.8 mm 842 x 632 mm 172 mm 38 x 29 mm	9.7 mm 2404 x 1803 mm 410 mm 58 x 44 mm	13.5, 1732 x 1299 mm 570 mm 41 x 31 mm
Angular Field of View	4.5 mm 88° 43' x 72° 30' 59 mm 8° 32' x 6° 24'	7.6 mm 60° 08' x 46° 57' 137 mm 3° 41' x 2° 46'	7.8 mm 58° 51' x 45° 52' 172 mm 2° 56' x 2° 12'	9.7 mm 48° 48' x 37° 35' 410 mm 1° 14' x 0° 55'	13.5 mm 36° 06' x 27° 28' 570 mm 0° 53' x 0° 40'
Filter Size	ø 127 mm P=0.75	ø 82 mm P=0.75	ø 95 mm P=1.0	ø 127 mm P=0.75	ø 127 mm P=0.75
Inner Focus	Yes	Yes	Yes	Yes	Yes
Macro	Yes	Yes	Yes	Yes	Yes
Weight (w/o hood)	1.83 kg	1.53 kg	1.25 kg	5.1 kg	5.2 kg

A13x4.5ERM-M: 2x Extender, Manual Focus, Servo Zoom
(Mfr # A13X4.5ERM-M • B&H # FUA13X45ERM)**20,789.95**

A13x4.5ERD-S: 2x Extender, Servo Focus and Servo Zoom
(Mfr # A13X4.5ERD-S • B&H # FUA13X4.5ERD)**22,234.50**

A13x4.5DERM-M: 2x Extender, 4:3 Ratio Converter, Manual Focus, Servo Zoom (Mfr # A13X4.5DERM-M • B&H # FUA13X4.5DEQ)**24,789.95**

A13x4.5DERD-S: 2x Extender, 4:3 Ratio Converter, Servo Focus and Servo Zoom (Mfr # A13X4.5DERD-S • B&H # FUA13X4.5DER)**26,234.95**

A18x7.6ERM-M: 2x Extender, Manual Focus, Servo Zoom
(Mfr # A18X7.6ERM-M • B&H # FUA18X76ERM)**11,219.95**

A18x7.6ERD-S: 2x Extender, Servo Focus and Servo Zoom
(Mfr # A18X7.6ERD-S • B&H # FUA18X76ERD)**12,799.95**

A18x7.6DERM-M: 2x Extender, 4:3 Ratio Converter, Manual Focus, Servo Zoom (Mfr # A18X7.6DERM-M • B&H # FUA18X76DERM)**15,707.95**

A18x7.6DERD-S: 2x Extender, 4:3 Ratio Converter, Servo Focus and Servo Zoom (Mfr # A18X7.6DERD-S • B&H # FUA18X76DERD)**16,799.95**

A22x7.8ERM-M: 2x Extender, Manual Focus, Servo Zoom
(Mfr # A22X7.8ERM-M • B&H # FUA22X78ERM)**19,959.95**

A22x7.8ERD-S: 2x Extender, Servo Focus and Servo Zoom
(Mfr # A22X7.8ERD-S • B&H # FUA22X78ERDS)**21,889.95**

A22x7.8ERM-M: 2x Extender, 4:3 Ratio Converter, Manual Focus, Servo Zooms (Mfr # A22X7.8DERM-M • B&H # FUA22X78DERM)**23,986.95**

A22x7.8DERD-S: 2x Extender, 4:3 Ratio Converter, Servo Focus and Servo Zoom (Mfr # A22X7.8DERDSB • B&H # FUA22X78DEQ)**25,439.50**

A42x9.7BERD-S: 2x Extender, Servo Focus, Servo Zoom
(Mfr # A42X9.7BERD-S48 • B&H # FUA42X97BERS)**46,599.95**

A42x9.7BERD-F48: Same as above with motor driven 2x
(Mfr # A42X9.7BERD-F48 • B&H # FUA42X97BERD)**48,729.95**

A42x13.5ERD-S48: 2x Extender, Servo Focus, Servo Zoom
(Mfr # A42X13.5BERD-S48 • B&H # FUA42X135BED)**50,679.95**

A42x13.5DERD-S: Same as above with motor driven 2x Lens
(Mfr # A42X13.5BERD-F48 • B&H # FUA42X135BER)**52,929.95**

2/3" PROFESSIONAL ENG LENSES

Professional-grade, wide-angle and telephoto ENG lenses for cost-effective, high-end program production, the A13x6.3B, A17x9B and A20x8.6B incorporate an inner focus mechanism to make the lenses compact and lightweight. This provides excellent mobility and an ease of operation. A dust-proof mechanism enhances anti-fogging and dust-preventive capability. Fujinon-proprietary optical simulation technology reduces axial chromatic aberration, magnification aberration, spherical aberration, and coma aberration. This results in a higher peripheral image resolution and image quality equivalent to that of standard broadcast lenses. Focus breathing is minimal giving added benefit to dramatic productions. A minimum object distance length of 0.4m (wide angle lenses) 0.9m (telephoto lenses) is possible for shooting at extremely close distances.



	A13x6.3BRM	A13x6.3BERM	A17x9BRM	A20x8.6BRM	A20x8.6BERM
Focal Length	6.3~82mm	(1x) 6.3~82mm (2x) 12.6~164 mm	9 to 155 mm	6.4~128 mm	(1x) 8.6~172mm (2x) 17.2~344 mm
Zoom Ratio	13x	13x	17x	20x	20x
Maximum Relative Aperture	1:2.0 (to 61mm) F2.7 (at 82 mm)	1:2.0 (to 61mm) F2.7 (at 82 mm)	F1.9 (to 115 mm) F2.6 (at 155 mm)	F1.4 (6.4~90 mm) 2 (128 mm)	1:1.8 (8.6~115 mm) 1:2.7 (172 mm)
M.O.D from Front of Lens	0.4 m	0.4 m	0.9 m	0.9 m	0.9 m
Object Dimensions at M.O.D.	6.3, 617mm x 463mm 82mm 47mm x 36mm	6.3, 617mm x 463mm 82mm 47mm x 36mm	6.3, 617mm x 463mm 82mm 47mm x 36mm	6.4, 846 x 635mm 128mm 42 x 32	8.6mm 866 x 650mm 172mm 43 x 33mm
Angular Field of View	6.3mm 69° 52' x 55° 18' 82mm 6° 09' x 4° 37'	6.3mm 69° 52' x 55° 18' 82mm 6° 09' x 4° 37'	9mm 52° 06' x 40° 16' 155mm 3° 15' x 2° 26'	6.4mm 53° 08' x 41° 07' 128mm 2° 52' x 2° 9'	8.6mm 54° 11' x 41° 59' 172mm 2° 56' x 2° 12'
Filter Size	82 mm	82 mm	ø 82 mm P=0.75	ø 82 mm P=0.75	ø 82 mm P=0.75
Inner Focus	Yes	Yes	Yes	Yes	Yes
Macro	Yes	Yes	Yes	Yes	Yes
Weight (w/o hood)	1.68kg	1.78 kg	1.25 kg	1.4kg	1.5kg

- A13x6.3BRM:** Manual Focus, Servo Zoom (Mfr # A13X6.3BRM • B&H # FUA13X63BRM)**6059.95**
- A13x6.3BERM:** 2x Extender, Manual Focus, Servo Zoom (Mfr # A13X6.3BERM • B&H # FUA13X63BERM).....**8979.95**
- A13x6.3BMD:** Video conferencing lens (Mfr # A13X6.3BMD • B&H # FUA13X63BMD)**6799.95**
- A13x6.3BEMD** Video conferencing lens with 2x Extender (Mfr # A13X6.3BEMD • B&H # FUA13X63BEMD)**9359.95**

- A17x9BRM:** Manual Focus, Servo Zoom (Mfr # A17x9BRM • B&H # FUA17x9BRM).....**CALL**
- A17x9BERM:** 2x Extender, Manual Focus, Servo Zoom (Mfr # A17x9BERM • B&H # FUA17x9BERM)**CALL**
- A17x9BMD:** Video conferencing lens (Mfr # A17x9BMD • B&H # FUA17x9BMD)**CALL**
- A17x9BEMD** Video conferencing lens with 2x Extender (Mfr # A17x9BEMD • B&H # FUA17x9BEMD).....**CALL**

- A20x8.6BRM:** Manual Focus, Servo Zoom (Mfr # A20X8.6BRM • B&H # FUA20X86BRM)**2899.95**
- A20x8.6BERM:** 2x Extender, Manual Focus, Servo Zoom (Mfr # A20X8.6BERM • B&H # FUA20X86BERM)**5999.95**
- A20x8.6BMD:** Video conferencing lens (Mfr # A20X86BMD • B&H # FUA20X86BMD)**4484.95**
- A20x8.6BEMD** Video conferencing lens with 2x Extender (Mfr # A20X8.6BEMD • B&H # FUA20X86BEMD)**8574.95**

ZOE-ENG

Zoom Controller for ENG Lenses

Weighing in at less than 140g including cable and connector, the Zoe-ENG is one of the smallest and lightest zoom grips on the market. The controller can be easily attached to any tripod handle up to $\varnothing 34\text{mm}$ and boasts a wide array features. The rocker allows users to adjust speeds for precision zoom control making it ideal for event coverage such as sporting events and concerts. Also controls record on/off, eliminating the need to move between camera and controller.



- ◆ Stepless zoom speed adjustment
- ◆ Record start/stop button
- ◆ Return function
- ◆ Reversible zoom direction
- ◆ Zoom-switch housing is made of fiber glass reinforced polycarbonate, which makes the Zoe-ENG nearly unbreakable.
- ◆ The shape of the housing protects the speed wheels and avoids accidental repositioning of the pre-adjustment.
- ◆ Special shape of the rocker switch allows you to put your thumb at three different places: middle, right or left. In any situation, you use the Zoe in a precise but comfortable way.
- ◆ Operating knobs are manufactured of plastic and stand out from the housing. They are mobile and give a clear feedback whether the respective function was operated or not. The Record button has a different shape than the Return button, which allows easy manipulation without looking.

Zoe-ENG-8 (Mfr # ZOE-ENG-8 ; B&H # BEZOEENG8)

For Canon, Angenieux, Fujinon lenses.....**544.95**

Zoe-ENG-12 (Mfr # ZOE-ENG-12; B&H # BEZOEENG12)

For Fujinon 12-pin lenses.....**544.95**

ZOE-DVXL Zoom Controller for Mini DV Camcorders



The Zoe-DVXL is an universal zoom control for Mini DV camcorders with LANC control (Canon and Sony) and CamRemote connection (Panasonic AG-DVC30, AG-DVX80, AG-DVX100 and AG-HVX200). It features a quick release clamp and click functions for switching quickly between manual and auto-focus. Elbow plug design provides additional durability by eliminating any bending that can occur when straight plugs are yanked at an acute angle. Maximum Speed Reduction (MSR) function allows users to specify the maximum speed of the controller. This can be done without losing any pressure sensitivity, resulting in much smoother slow zoom drives. Additionally, the ZOE-DVXL can also control the record function on the camera, eliminating the need to move between the camera and the controller.

- ◆ Selector switch between DVL- and DVX-mode allows universal operation
- ◆ Rugged elbow plug gives you two advantages: The cable goes along the camera, therefore looking better than being at a 90° angle from the housing of the camera. If you pull the cable unintentionally, it will not bend the plug
- ◆ The coiled cable has a total length of 90 cm when it pulled out, which is more than enough between pan arm and camera. If you pull the cable unintentionally, the coiled cable avoids damaging the plug into the camera.
- ◆ Housing protects the speed wheel and avoids repositioning of the pre-adjustment.
- ◆ Quick-release clamp facilitates attachment to standard tripod arms up to 34mm in diameter or onto the camera grip.
- ◆ Ergonomically contoured shape of the rocker switch allows you to put your thumb at three different places: middle, right or left. In any situation, you use the Zoe in a precise but comfortable way.

Zoe-DVXL (Mfr# ZOEDVXL • B&H# BEZOEDVXL): Zoom controller for Mini DV camcorders.....**239.95**

ZOE-EX

Zoom Controller for Sony PMW-EX1

Designed for the Sony PMW-EX1, the ZOE-EX1 offers a full range of innovative remote functions, including variable stepless zoom speed control, record start/stop button, return function, and reversible Zoom direction. Housed in a streamlined, casing of lightweight, durable shock-resistant polycarbonate, ZOE-EX adjusts zoom function through the system's innovative pressure-sensitive rocker switch. Speed of the zoom is in direct relation to the pressure applied to the control. Integrated software prevents stuttering when changing speed or direction. The result: truly stepless zooms, silky smooth ramp-up and precise manipulation, regardless of speed.



- ◆ Ergonomically contoured for maximum comfort and ease of use, the rocker offers three thumb positions — left, right, or center, and is capable of 133° of rotation — the most offered with this type of control. This allows for greater control and more sensitive manipulation of the zoom function.
- ◆ Controls are handily located on top. Return Record, and Direction buttons are distinctively shaped for fast and easy touch recognition.
- ◆ To safeguard against dirt, rain or other environmental hazards, all controls are covered with a vinyl protective layer.
- ◆ Zoom ramping speed is pre-adjusted via a convenient rotating selector wheel on one side of the unit.
- ◆ The shape of the housing protects the wheel from damage and prevents accidental repositioning of settings.
- ◆ An ergonomic jack and a countersunk potentiometer avoid accidental activation.
- ◆ Set up is quick and easy. The Zoe ENG's quick-release clamp attaches to tripod panhandles of up to 34mm diameter. Its 11.8" cable extends to 35", providing ample room between the camera and panhandle. A rugged 90° elbow plug connects neatly to the camera's output.

Zoe-EX (Mfr # ZOE-EX1 • B&H # BEZOEEX1): Zoom Controller for Sony PMW-EX1**374.95**



FOXI Focus and Iris Controller for the HVX-200/AG-DVX100B

FOXI is a high quality remote focus/iris controller designed specifically for the Panasonic AG-DVX100A/B and AH-HVX200 cameras. The unit's design can fit onto any tripod handle, giving the user precision focus control without the high costs of a traditional mechanical follow focus system. Controls focus (rotating knob), switching between auto and manual focus, iris (slider paddle) and switching between auto and manual iris. The focus and iris both have scales which can be noted with mark points, making repeatable focus-racking a breeze.



- ◆ The Focus knob is designed in similar style to a Follow-Focus knob with a diameter of 60mm with an approximate 270° of rotational travel. A built in non adjustable fluid friction allows slow, accurate and repeatable Focus control movements.
- ◆ Control of the iris is made using a throttle design sliding paddle indicator.
- ◆ Two sliding-switches located at the bottom of the Foxi housing allows toggling from auto to manual focus and iris and vice versa.
- ◆ It can be mounted to a tripod pan arm for studio configuration or on 15mm light weight mattebox rods for cinema configuration (using the supplied spacer bracket).
- ◆ Both focus and iris offers markable scales.
- ◆ In extent of supply for the quick-release clamp a spacer is enclosed. This allows enough place between Foxi and camera case to be engaged comfortably appropriately at the camera control elements (particularly AWB).
- ◆ Designed to be used with the Zoe-DVXL Zoom Remote.

FOXI Focus/Iris Control (Mfr # FOXI; B&H # BEFOXI): For Panasonic AG-DVX100/A/B and AG-HVX200**469.95**

FOXI Focus/Iris Control and ZOE-DVXL Zoom Controller (Mfr # FOXIDVXL; B&H # BEFOXIDVXL): For Panasonic AG-DVX100/A/B and AG-HVX200. (Both units can attach to tripods or rod systems, providing professional-level camera control)**649.95**



PRO-C • PRO-F

Professional Zoom Controls Canon or Fujinon Lenses

Heavy-duty aluminum housing, dual-variable speed control, and affordable price make these zoom controls ideal for Canon 8-pin (Pro-C) and Fujinon 8-pin (Pro-F) video lenses. Incorporating precision dual potentiometers and unique zoom handle grip, they provide remote zoom control for nearly every acquisition situation. Able to clamp to any tripod handle, jib, or support bar, they feature a dual-variable system for versatile, precise control of zoom speed. Set the maximum desired speed on the dial (located in a 'trigger' position), then use the pressure-sensitive rocker to vary the speed from a crawl all the way up to the preset max. Alternatively, depress the rocker fully and roll the dial with your index finger to ramp the speed up.

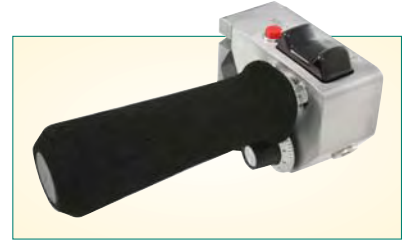

- ◆ Combination of pressure-sensitive zoom rocker and speed dial provides precise dual-variable zoom control
- ◆ Speed dial acts as a limiter for max speed or a 'ramping' device
- ◆ Large, safely-located record/pause button
- ◆ Rubber-foam grip for comfort

- ◆ Heavy-duty aluminum housing and quick-release clamp
- ◆ Video return button plays back the last 5 seconds of recorded material and cues the tape up to the last recorded frame to ensure proper timecode sync

VZ-Pro-C: Pro zoom controller for 8-pin Canon lenses (Mfr# VZPROC; B&H# VAVZPROC)**379.95**

VZ-Pro-F: Pro zoom controller for 8-pin Fujinon lenses (Mfr# VZPROF; B&H# VAVZPROF)**379.95**

VZ-Pro-F12: Pro zoom controller for 12-pin Fujinon Lenses. Kit with 5.6" LCD monitor (Mfr# VZ-USPG-F12 • B&H# VAVZUSPGF12)**1254.95**

PG-C • PG-F Professional Zoom Controls with Pivot Clamp

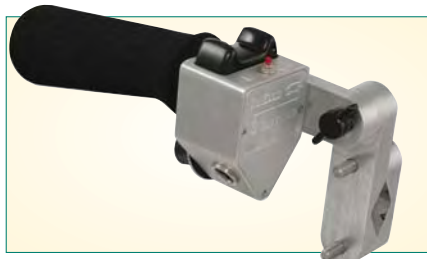

Stepping up from the Pro-C and Pro-F, the PG-C and PG-F are pistol-grip zoom controls for Canon and Fujinon lenses that utilize the finest components and have a beautifully machined aluminum housing and articulated clamp. Otherwise the same, they will also clamp to any tripod handle, jib, or support bar, and they feature a dual-variable system for versatile, precise control of zoom speed.

- ◆ Rubber-foam grip with a 'pistol grip' curve for ergonomic comfort
- ◆ Beautifully machined and engraved aluminum housing
- ◆ Heavy-duty, quick-release aluminum swivel clamp for angular adjustment of handle position.
- ◆ Designed for use with left or right hand

VZ-PG-C Deluxe Zoom Controller for 8-pin Canon Lenses (Mfr # VZPGC; B&H # VAVZPGC)**479.95**

VZ-PG-F Deluxe Zoom Controller for 8-pin Fujinon Lenses (Mfr# VZPGF; B&H# VAVZPGF)**479.95**

VZ-PG-F12 Deluxe Zoom Controller for 12-pin Fujinon Lenses (Mfr# VZPGF12 • B&H# VAVZPGF12).....**474.95**

ROCK-C • ROCK-F Mini Zoom Control for Canon or Fujinon Lenses

Compact, lightweight and affordable control for Canon or Fujinon professional lenses. The Rock-C or Rock-F feature a high-sensitivity rocker and speed limiter knob, allowing precise repeatable zooms to be easily achieved. Ideal for use on jibs, stabilizers, or applications where size and weight are critical.

- ◆ Pressure-sensitive zoom rocker and limiter knob for setting maximum speed
- ◆ Industrial strength aluminum body w/ ABS clamp to prevent scratched handles
- ◆ Low profile record/pause button
- ◆ Video return button plays back the last 5 seconds of recorded material and cues the tape up to the last recorded frame to ensure proper timecode sync



VZ-ROCK-C Compact Rocker Zoom Controller for 8-pin Canon Lenses (Mfr # VZROCKC; B&H # VAVZROCKC)**314.95**

VZ-ROCK-F Compact Rocker Zoom Controller for 8-pin Fujinon Lenses (Mfr # VZROCKF; B&H # VAVZROCKF)**314.95**

FCC • FCF

Cable-Drive Focus Control for Canon or Fujinon Lenses

Precisely adjust focus on your Canon or Fujinon lens from the tripod handle using these studio-style remotes. A hefty aluminum rotating grip drives the custom-machined focus gearbox using an industrial wound-core cable, allowing smooth control of the focus ring.

- ◆ Heavy-duty focus handle with articulated swivel clamp for angular position adjustment
- ◆ High-precision gear box fits on most Canon or Fujinon lenses
- ◆ 40" industrial drive cable accommodates any tripod configuration and provides smooth manual control
- ◆ Handle and cable are also compatible with other VariZoom gear boxes - buy one complete FC-C or FC-F focus control set, then just buy the VZ gear box for your other Canon or Fujinon lens for savings



	Cable-Drive Focus Control	Silver Version		Black Version	
FC-C	for Canon Pro Lenses	Mfr# VZ-FC-C • B&H# VAVZPROFCC	449.95	FCC-B	Mfr# VZ-FC-C-B • B&H# VAVZFCCB 469.95
FC-X	for Canon XL-2 16x lens	Mfr# VZ-FC-X • B&H# VAVZFCX	379.95	FCX-B	Mfr# VZ-FC-X-B • B&H# VAVZFCXB 469.95
FC-F	for Fujinon Pro Lenses	Mfr# VZ-FC-F • B&H# VAVZFCF	459.95	FCF-B	Mfr# VZ-FC-F-B • B&H# VAVZFCFB 469.95
FC-F22	for small Fujinon Lenses	Mfr# VZ-FC-F22 • B&H# VAVZFCF22	469.95	FCF22-B	Mfr# VZ-FC-F22-B • B&H# VAVZFCF22B 469.95



EFC Electronic Focus Controller

Designed for use on jibs or other remote applications, this programmable remote focus control for Canon or Fujinon professional lenses allows the user to adjust focus manually or preset up to 4 quick-change positions.

- ◆ Universal aluminum servo focus bracket for Canon or Fujinon lenses
- ◆ Full Manual Mode for the finest focus adjustments
- ◆ Programmable Mode for presetting up to 4 preset focal points
- ◆ LCD readout for positioning and programming
- ◆ Includes control unit, servo focus bracket, 20' cable, carrying pouch, Canon gear, Fujinon gear, cable straps, rechargeable battery kit
- ◆ Works up to 50' (extensions available in 10' increments)
- ◆ Rechargeable battery with LED capacity indicator

VZ-EFC Electronic Focus Controller with 20' Cable (Mfr # VZEFC • B&H # VAVZEFC)**659.95**

Studio Kits

- VZ-SPro-C:** Pro-C Zoom Control Grip and FC-C Focus Control for Canon lenses (Mfr # VZSPROC • B&H # VAVZSPROC)**799.95**
- VZ-SPG-C:** PG-C Zoom Control Grip and FC-C Focus Control for Canon lenses (Mfr# VZSPGC • B&H# VAVZSPGC)**899.95**
- VZ-SPro-F:** Pro-F Zoom Control Grip and FC-F Focus Control for Fujinon lenses (Mfr# VZSPROF • B&H# VAVZSPROF)**799.95**
- VZ-SPG-F:** PG-F Zoom Control Grip and FC-F Focus Control (Mfr# VZSPGF • B&H# VAVZSPGF)**899.95**
- VZ-SPro-X:** Pro-L LANC Zoom/Focus Controller and FC-X Manual Focus for Canon XL Series 16x Manual Zoom Lens (Mfr# VZ-SPRO-X • B&H# VAVZSPROX)**749.95**
- VZ-SPG-X:** Same as above except with the PG-L LANC Zoom/Focus Controller (Mfr# VZ-SPG-X • B&H# VAVZSPGX)**769.95**



FOCUS/ZOOM CONTROL KITS

VZ-USPro-C: Includes Pro-C Zoom Controller and FC-C Manual Focus for Canon Lenses, VZ-TFTU 5.6" 4:3 LCD Monitor, Shoe Mount, Sun Hood, Rechargeable Battery, Battery Charger (Mfr# VZ-USPRO-C • B&H# VAVZUSPROC)**1159.95**

VZ-USPG-C: Same as above except with the PG-C Zoom Controller, (Mfr# VZ-USPG-C • B&H# VAVZUSPGC)**1254.95**

VZ-USPG-X Canon XL Series Studio Kit: Z-PG-L Zoom Controller, VZ-FC-X Manual Focus Controller, VZ-TFTU 5.6" LCD Monitor, Shoe Mount, Sun Hood, Rechargeable Battery, Battery Charger (Mfr# VZ-USPG-X • B&H# VAVZUSPGX)**1149.95**

VZ-SPro-F Studio Kit for 8-Pin Fujinon Lenses: Includes VZ-Pro-F Zoom Controller, VZ-FC-F Manual Focus Controller, VZ-TFTU 5.6" 4:3 LCD Monitor, Shoe Mount, Sun Hood, Rechargeable Battery, Battery Charger (Mfr# VZUSPROF • B&H# VAVZUSPROF)**1159.95**

VZ-USPG-F2 Fujinon Studio Kit for 1/2" Lenses: Includes VZ-PG-F Zoom Controller, VZ-FC-F22 Manual Focus Controller, VZ-TFTU 5.6" 4:3 LCD Monitor, Shoe Mount, Sun Hood, Rechargeable Battery, Battery Charger (Mfr# VZ-USPG-F2 • B&H# VAVZUSPGF2)**1254.95**

VZ-USPG-F12 Fujinon 12-Pin Studio Kit: VZ-Pro-F12 Zoom Controller, VZ-FC-F Manual Focus Controller, VZ-TFTU 5.6" 4:3 LCD Monitor, Shoe Mount, Sun Hood, Rechargeable Battery, Battery Charger. (Mfr# VZ-USPG-F12 • B&H# VAVZUSPGF12)**1254.95**

VZ-USPRO-F2 Fujinon Studio Kit for 1/2" Lenses: Includes VZ-Pro-F Zoom Controller, VZ-FC-F22 Manual Focus Controller, VZ-TFTU 5.6" 4:3 LCD Monitor, Shoe Mount, Sun Hood, Rechargeable Battery, Battery Charger. (Mfr# VZ-USPRO-F2 • B&H# VAVZUSPROF2)**1199.95**

VZ-USPG-F Fujinon 8-Pin Studio Kit: Includes VZ-PG-F Zoom Controller, VZ-FC-F Manual Focus Controller, VZ-TFTU 5.6" 4:3 LCD Monitor, Shoe Mount, Sun Hood, Rechargeable Battery, Battery Charger. (Mfr# VZ-USPG-F • B&H# VAVZUSPGF)**1254.95**



VZ-CPG-C Focus Gear



VZ-SPG-C

Wireless Focus Control Kit



The Wireless Focus Control kit provides you with the focal control you require via a wireless 900MHz Data Transmission link, with 8 selectable sub channels at your fingertips. This kit is completely intuitive and modular, requiring minimal setup and power, and can be integrated into your current camera configuration seamlessly. The Wireless Focus Control kit consists of a hand-held Transmitter Control Unit, a Receiver/Amplifier Motor Driver Unit, a Lens Drive Motor complete with a set of Lens Gears, Lemo Type B 5 pin connector, and a water-tight Hard Case for easy transportation to your next filming.

- ◆ Transmitter and Receiver provides a 900MHz Data Transmission Link via 8 selectable sub channels
- ◆ Lens motor is able to focus lenses in temperatures below freezing
- ◆ Lens motor drive manufactured in high grade titanium and aluminum alloys
- ◆ Articulating connector for cable management
- ◆ Motor shuts down automatically as a power saving feature
- ◆ Control Module powered by a 9V battery for 18 hours of operation
- ◆ Can be used with both continuous operation or momentary operation cameras
- ◆ Hard case is water tight

VZ-WFF Wireless Follow Focus System with Case (Mfr# VZ-WFF • B&H# VAVZWFF)**4799.95**

MC100

Pan and Tilt Control System

A powerful tool, the MC100 weighs only 8 lbs., yet allows remote operators to execute smooth, variable-speed 360° pan and tilt movements with camcorders weighing up to 20 lbs. from up to 500' away. Whether mounted on a jib or crane, placed on a tripod as a 'robotic cameraman', or integrated into permanent A/V systems in studios, churches or auditoriums, you have full capability to pan and tilt from the slowest sustained crawl to the rapid moves needed to follow the action. No jib is complete without a motorized pan/tilt head, and the MC100's lightweight, universal mounting base, and intuitive compact control box make it a breeze to set up and operate on virtually any jib.



FEATURES

- ◆ Lightweight and portable, the MC100 offers fast setup and several mounting options: Mount upright or underslung to any jib, tripod or wall mount. Flat mounting base can be adapted to nearly any surface or ball head tripod.
- ◆ Adjustable balancing system allows for complete 360° rotation for both pan and tilt.
- ◆ Smooth and quiet operation at any speed.
- ◆ Dual variable speed control with dial presets and pressure-sensitive joystick.
- ◆ Operate up to a distance of 500' away.
- ◆ When used with a VariZoom remote focus and zoom controller you will possess the most powerful acquisition tool — a complete camera control with smooth pan, tilt, zoom, and focus.
- ◆ All of the electronics necessary to drive the precision pan and tilt head are compacted into one small control housing, allowing for portability and versatility.
- ◆ Precision CNC machining, top-shelf components, rigorous inspection, and thorough individual unit testing ensure the highest quality.
- ◆ Modular architecture makes parts replacement and repair simple.
- ◆ Included custom lightweight carrying case with die-cut foam insert protects the MC100 during storage or transport via air or land.
- ◆ While not cheap, the MC100 is considerably cheaper than units of comparable quality and capability. The cost of renting a professional pan/tilt head alone makes it worth considering.

VZ-MC100: Pan and Tilt Control System (Mfr # VZMC100 • B&H # VAVZMC100)
Includes pan & tilt head, pan & tilt control grip/box, 20' of pan & tilt motor cord, 4-pin XLR power supply, heavy-duty hard carrying case**2859.95**

VZ-CS1LK: Remote Motion Control Kit (Mfr # VZCS1LK • B&H # VAVZCS1LK)
The VZ-CS1LK is a complete remote camera control station that combines the MC100 pan/tilt head, VZ-Pro-L zoom/focus/record control of LANC-equipped Sony or Canon cameras, Z-TFT-7 16:9 widescreen 7" LCD monitor, and CS1 control station frame for mounting all components**4098.95**

MC100 Dual System (Mfr # VZ-MC100-DUAL • B&H # VAVZMC100D)
The MC100D allows a single operator to have complete motion control over two cameras over a 100' apart. Great for weddings and event videographers. Lightweight head mounts to nearly any jib or tripod and can be integrated into permanent AV systems in studios, churches, or auditoriums.....**4799.95**



VZCS1LK Dual System

Includes two VZ-MC100 pan/tilt heads, one VZ-Rock camera control for zoom, focus, record control of LANC-equipped Sony or Canon cameras, two VZ-TFT-7 16:9 widescreen 7" LCD monitors, and VZ-CS1 control station frame for mounting all components. (Mfr # VZ-CS1LK-DUAL • B&H # VAVZCS1LKD)**5399.95**

COMPACT LENS CONTROLLERS

VZ Stealth • VZ Stealth LX

Compact, affordable and versatile LANC controller, the Stealth has a unique variable-speed throttle for controlling zooms from the slowest crawl up to the fastest. Easy to operate and perfect for use on all camera supports, stabilizers, tripods, & jibs.

A stylish, lightweight body houses proprietary electronics. The pressure-sensitive 'throttle' control allows you to ease into zooms in either direction, hold a steady speed, or instantly accelerate into a 'crash' zoom. The Stealth is completely intuitive and smooth, requiring no setup, power, or operator skill. This unique miniature control offers unmatched convenience, value, and performance. Otherwise identical, the Stealth LX steps up with three extra features: Autofocus On/Off, Data On/Off, and Tape Search.

- ◆ Throttle provides variable-speed zoom control
- ◆ Dedicated "rocker style" focus button
- ◆ Low profile record/pause button
- ◆ Power On/Off button for toggling camera into or out of standby mode
- ◆ LED light indicates recording, low battery power, and tape end

VZ-STEALTH (Mfr # VZ-STEALTH • B&H # VAVZSTEALTH).....**189.95**



VZ- Stealth LX Step-up Features

- ◆ Switch between auto and manual focus with the 'A' button
- ◆ Toggle onscreen information (tape time, settings) on and off with 'Data' button
- ◆ Review taped footage with F+ & F- (edit search)

VZ-Stealth-LX (Mfr # VZ-STEALTH-LX • B&H # VAVZSTEALTHL).....**219.95**



VZ-Rock • VZ-Rock LE

VariZoom's most popular LANC unit, the VZ-Rock offers the finest degree of control and a complete feature set. With its wide-sweep zoom rocker, the VZ-Rock combines the attributes of broadcast controls with a compact, affordable design. By utilizing a pressure-sensitive, side-to-side rocker switch like broadcast lens controls, the VZ-Rock offers a greater range of motion for a finer degree of zoom control. Otherwise the same, the limited-edition engraved Rock-LE offers all the advantages and features of the VZ-Rock, but adds an industrial-strength aluminum housing. This totally unique controller bridges the gap between 'prosumer' and 'professional'.

- ◆ Wide-sweep variable rocker for smooth, sustainable zooms
- ◆ Dedicated "rocker style" focus button
- ◆ Low profile record/pause button
- ◆ Power On/Off button for toggling camera into or out of standby mode
- ◆ Switch between auto and manual focus
- ◆ Toggle onscreen information (tape time, settings) on and off with 'Data' button
- ◆ Review taped footage with F+ & F- (edit search)
- ◆ LED light indicates recording, low battery power, and tape end

VZ-Rock Compact Variable Rocker (Mfr# VZ-ROCK • B&H# VAVZROCK).....**229.95**

VZ-Rock LE Variable Rocker (Mfr# VZ-ROCK-LE • B&H# VAVZROCKLE).....**289.95**

Pro-L • PG-L

Built to last a lifetime with an aluminum housing, isolated circuit board, and industrial components, the Pro-L employs a rocker and speed dial for 'ramping' or presetting zoom speeds with flawless, full-range precision. Equally durable and reliable, the PG-L is the compact, pistol-grip version of the Pro-L. Utilizing the same electronics as the Pro-L, the PG-L is designed for users with small hands or are left-handed.

- ◆ Patented speed dial with rocker in pistol-grip configuration allows for preset or ramping of zooms
- ◆ Power On/Off for toggling into or out of standby mode
- ◆ Rubber-foam grip for operator comfort
- ◆ Heavy duty quick-release clamp system
- ◆ Industrial-grade aluminum housing
- ◆ Large, safely-located record/pause button (Pro-L)
- ◆ Large manual focus buttons located on underside of unit (Pro-L)
- ◆ Centrally-located record and manual focus buttons (PG-L)

VZ-PRO-L Zoom Controller (Mfr# VZ-PRO-L • B&H# VAVZPROL).....**324.95**

VZ-PG-L Zoom and Focus Controller (Mfr# VZ-PG-L • B&H# VAVZPGL).....**349.95**



COMPACT LENS CONTROLLERS

VZ Stealth-EX

The Stealth-EX is the ideal solution for the videographer who needs a very compact, lightweight zoom control for the Sony PMW-EX1. The pressure-sensitive 'throttle' control allows you to ease into zooms in either direction, hold a steady speed, or instantly accelerate into a 'crash' zoom. The Stealth is completely intuitive and smooth, requiring no setup, power, or operator skill. This unique miniature control offers unmatched convenience, value, and performance.

- ◆ Throttle provides variable-speed zoom control
- ◆ Video return button plays back the last 5 seconds of recorded material
- ◆ ABS clamp to prevent scratched handles
- ◆ Low profile record/pause button



VZ Stealth EX Lens Controller for Sony PMW-EX-1 (Mfr # VZSTEALTHEX; B&H # VAVZSTEX)**279.95**



VZ Rock PZFI

Specifically designed for Panasonic HVX200 and DVX100B, this is the first and only zoom, focus, and iris control. This powerful combination offers precise control over these three camera functions. You can switch between auto and manual control for either focus or iris at anytime. Works on all camera supports, stabilizers, tripods, & jibs. It utilizes a pressure-sensitive, side-to-side rocker switch similar to broadcast zoom controls, which has a greater range of motion for a finer degree of zoom control than the throttle style zoom controls. Adjust the exposure or focus with a finger, smooth and quiet knobs provide easy operation while you compose your shots. Independent focus/iris knobs allow for two people to operate together for critical focus during moving shots or crane moves, imagine the possibilities! The body switches click into position, letting you watch the picture, not your hands.

- ◆ Wide-sweep variable rocker for smooth, sustainable zooms
- ◆ Unique dual knob adjustment
- ◆ Low profile record/pause button
- ◆ Body switches for manual/auto modes

VZ RockPZFI (Mfr # VZROCKPZFI; B&H # VAVZROCKPZFI)**274.95**

VZ PFI

Specifically designed for Panasonic HVX200 and DVX100B cameras, the affordable and versatile PFI offers precision focus and iris control. Operator may switch between auto and manual at anytime. Works on all camera supports, stabilizers, tripods, & jibs. A stylish, lightweight body houses our unique dual knob adjustment system, which allows you to ease into proper focus and exposure in either direction. Independent focus/iris knobs allow for two people to operate together for critical focus during moving shots or crane moves, imagine the possibilities! The body switches click into position, letting you watch the picture, not your hands. The VZ-PFI is completely intuitive and smooth, requiring no setup, power, or operator skill. This unique miniature control is a perfect compliment to a Panasonic Zoom controller. (Mfr # VZPFI; B&H # VAVZPFI)**189.95**

VZ StealthPZFI

Specifically designed for the Panasonic HVX200 and DVX100B, this is the first and only zoom, focus, and iris control. This powerful unit combines the rich feature set of our PZFI controllers with the unique variable-speed throttle of the Stealth series. Operator may switch between auto and manual control for either focus or iris at anytime. Works on all camera supports, stabilizers, tripods, & jibs.

A stylish, lightweight body houses our pressure-sensitive 'throttle' control, which allows you to ease into zooms in either direction, hold a steady speed, or instantly accelerate into a 'crash' zoom. The StealthPZFI is completely intuitive and smooth, requiring no setup, power, or operator skill. This unique miniature control offers unmatched convenience, value, and performance. Independent focus/iris knobs allow for two people to operate together for critical focus during moving shots or crane moves, imagine the possibilities! The body switches click into position, letting you watch the



picture, not your hands. (Mfr # VZSTEALTHPZFI; B&H # VAVZSHVX200)**229.95**

CAMCORDER LENSES

EX 0.45x Super Fisheye Adapter

The EX Super Fisheye is a single-element fisheye adapter for today's compact HDV camcorders. A favorite of skateboarders and extreme sports photographers, fisheye lenses expand the view of the lens, providing a wide-eyed perspective that pulls the eye close to the center of the action. Images appear convex with exaggerated angles and extreme barrel distortion. By adding a full .45x magnification, the EX Super Fisheye is simply the widest single-element fisheye on the market. Added to the front of the HVX200, AG-DVX100B, it delivers a 115° horizontal and 135° diagonal field of view. 72mm screw-in rear threads allow it to work equally well with similar sized camcorders. Also includes an adapter for 82mm threads.

(Mfr # 169HDVFSX82 • B&H # 16HDVFSX82)**599.95**



EX 0.4x Compact Super Fisheye Adapter



A smaller, lighter version of the ultra wide-angle EX Super Fisheye, the EX Compact Super Fisheye is a single-element fisheye adapter custom crafted to meet the higher demands of the new higher resolution, compact

HD camcorders. Adding 0.4x magnification, the EX Compact Super Fisheye expands the view of the camera's original lens, for a wide-eyed perspective that draws the eye closer to the center of the action. Images take on a convex appearance with exaggerated angles and extreme barrel distortion. Weighing only 6.6 oz., this ultra-light adapter is an excellent optical tool for handheld work. The 72mm screw-in rear thread attaches neatly to the front of most HD camcorder lenses. Comes equipped with step-down rings for camera's without a 72mm front. For Canon XH-A1, XH-G1, XL-H1A, XL-H1S, XL-H1, XL-2, Sony HDR-FX1, HVR-Z1, HVR-Z7U, HVR-S270U and HVR-V1U.

(Mfr # 169-HDCSF4X-72 • B&H # 16HDCSF4X72)**399.95**

1.5x Teleconverter

A lightweight (21 oz.), and compact production tool, the 1.5x mounts to the front the Canon XH-A1, XH-G1, XL-H1A, XL-H1S, XL-H1, XL-2, Sony HDR-FX1, HVR-Z1, HVR-Z7U, HVR-S270U and HVR-V1U. For professional shading solutions, the unit comes complete with a lightweight, round hood. The EX 1.5x lens front is threaded to accept either the complimentary hood, 86mm glass filters - or a combination of filter with the hood front mounted for even greater light control.

(Mfr # 169HDVT15X72 • B&H # 16HDVT15X72)**795.00**



0.7x Wide Converter

Don't limit yourself to the range of your camcorder's built-in zoom lens. 16x9's 0.7x Wide Angle converter offers a top-quality and cost-effective method of obtaining wider angle images with the Canon XH-A1, XH-G1, XL-H1A, XL-H1S, XL-H1, XL-2, Sony HDR-FX1 and HVR-Z1.

Made in Japan, craftsmanship is meticulous in every detail. Materials are the finest grade available. This top quality optical product employs three multi-coated optical glass elements to yield clean, high definition pictures.

(Mfr # HDV7X1 • B&H # 16HDV7X1)**499.95**



EX 0.7x Wide Converter



Designed for the Sony HVR-V1U and other compact HD camcorders, the EX 0.7x is a professional optic that attaches to the camera's 62mm threads for 30% more wide-angle coverage than the lens alone affords. When installed, the EX 0.7x modifies the camera's original 3.9-78mm lens to a wider 2.73-54.6mm focal length. The lens retains its full zoom

capabilities and there is no light loss or vignetting.

The converter features an 82mm front thread which permits users to directly mount glass filters and other accessories in front of the optic. Plus the EX 0.7x is fully compatible with popular mattebox systems such as Chrosziel. (Mfr # 169-HDV7-X62 • B&H # 16HDV7X62)**379.95**

EX 0.75x Wide Converter

The EX 0.75x precision glass lens expander deliver more telephoto reach or increased wide-angle view while maintaining exceptional image quality to realize the camcorder's full potential.

Manufactured in Japan, the EX 0.75x is impeccably crafted of the finest grade materials and features a cutting-edge HD-quality design. Four multi-coated glass elements reduce geometric distortion and improve off-axis wide angle performance, particularly chromatic aberrations and flatness of field. Includes a 72:82mm step-up ring that screws into the front of a Panasonic DVX-100 and HVX-200. Moreover, it features a convenient 72mm screw-in rear thread that screws into the front of most popular DV/HDV camera lenses. Fits the Canon XH-A1, XH-G1, Sony HVR-Z1, HVR-Z7U, HVR-S270U and the Panasonic AG-DVX100 and HVX-200. (Mfr # 169HDV75X82 • B&H # 16HDV75X82)**799.95**



BREVIS35



HD Imaging Adapter

Brevis35 is a sophisticated intermediate optical adapter which allows videographers to use high quality optics—including 35mm still-photography lenses—on small video cameras. The effect is a 35mm-style film look, complete with narrow depth of field and film-like grain. What makes the Brevis35 so unique is its ability to achieve these desired effects without significant light loss, which can be very important to small-sensor cameras.

- ◆ Micro collimation ring allows you to precisely adjust the backfocus of your lens mount. You can now have the perfect focus with your lens set to infinity.
- ◆ With eight interchangeable lens mounts, the Brevis 35 allows you to choose from a variety of lenses, including Nikon F, Canon FD and EOS, Pentax K and M42, and Minolta MD camera lens mounts, as well as PL and OCT19 cinema lens mounts.
- ◆ The only adapter that offers the performance and variable bokeh of interchangeable imaging elements. This allows you to select the element that works best with your camera, as well as your creative solution.
- ◆ The Brevis contains internal rechargeable batteries that will run approximately 20 hours on a full charge. The charger doubles as an AC adapter. Can also be run with two AA batteries, via the PowerPod.
- ◆ The optional Brevis Flip Module allows you to see the image in the correct orientation, without needing an external flipping monitor or other workarounds. Due to the changed optical path, you will see the improved edge sharpness and light distribution. Light loss is around 0.5 stops.
- ◆ Kits include Brevis35 HD Adapter, AC Adapter/Charger, Pelican Case and 72mm HD Achromat.

For 37mm Filter Threads (Mfr # 37-CF1-NF-MP1 • B&H # CI37CF1NFMP1) **1052.95**
 For 43mm Filter Threads (Mfr # 43-CF1-NF-MP1 • B&H # CI43CF1NFMP1) **1052.95**
 For 58mm Filter Threads (Mfr # 58-CF1-NF-MP1 • B&H # CI58CF1NFMP1) **1052.95**
 For 67mm Filter Threads (Mfr # 67-CF1-NF-MP1 • B&H # CI67CF1NFMP1) **1052.95**
 For 72mm Filter Threads (Mfr # 72-CF1-NF-MP1 • B&H # CI72CF1NFMP1) **1052.95**
 For 77mm Filter Threads (Mfr # 77-CF1-NF-MP1 • B&H # CI77CF1NFMP1) **1052.95**
 For 82mm Filter Threads (Mfr # 82-CF1-NF-MP1 • B&H # CI82CF1NFMP1) **1052.95**

With Flip Module

For 37mm Filter Threads (Mfr # 37-CF1-FL-MP1 • B&H # CI37CF1FLMP1) **1436.50**
 For 58mm Filter Threads (Mfr # 58-CF1-FL-MP1 • B&H # CI58CF1FLMP1) **1436.50**
 For 67mm Filter Threads (Mfr # 67-CF1-FL-MP1 • B&H # CI67CF1FLMP1) **1436.50**
 For 72mm Filter Threads (Mfr # 72-CF1-FL-MP1 • B&H # CI72CF1FLMP1) **1436.50**
 For 77mm Filter Threads (Mfr # 77-CF1-FL-MP1 • B&H # CI77CF1FLMP1) **1436.50**
 For 82mm Filter Threads (Mfr # 82-CF1-FL-MP1 • B&H # CI82CF1FLMP1) **1436.50**

LETUS DIRECT

LETUS35 35mm SLR Video Adapters

The Letus35 Mini and Letus35 Extreme are adapters which allow users to attach a standard 35mm SLR lens to their video camera. This allows film and video users to give their production the look of a high budget feature. The unique Letus35 features new prism technology with proprietary Image Orientation Correction technology. Unlike other 35mm adapters, this adapter “flips” the image upright so that the camera can record as it normally would. Components include the highest optical grade achromatic lens, a custom condenser lens and an improved ground glass element. These components work together to provide beautiful film-look bokeh, absolutely no vignetting, accurate color reproduction and crisp edge-to-edge sharpness with only a 1/2 stop of light loss.

They are milled from solid aluminum with an anodized black finish. A built-in on/off LED switch with indicator operates the virtually silent adapter ground glass vibration mechanism. Power is provided by two AA batteries that are fully enclosed in the adapter under a magnetic cover. Several thread sizes are available including 72mm threads for Canon cameras such as the XH-A1, 82mm threads for Panasonic cameras such as the HVX-200, and 77mm thread size for the Sony PMW-EX1. The Letus35 Extreme can be configured with several 35mm SLR lens mounts. Current mounts include Canon FD, Nikon AI, Canon EF (EOS) and Pentax K-Mount. Otherwise the same, the Letus35 Mini is half the weight of the Extreme (only 24 oz.) for hand held balance. No support rods needed. It is designed for cameras with a 43mm or smaller filter size.



Letus35 Mini with 37mm Adapter Ring
 (Mfr # LT35MINI37 • B&H # LET35M37) **1079.95**

Letus35 Mini with 43mm Adapter Ring
 (Mfr # LT35MINI43 • B&H # LET35M43) **1079.95**

Letus35 Extreme with 72 mm Adapter Ring
 (Mfr # LT35EX72 • B&H # LET35EX72) **1149.95**

Letus35 Extreme with 77 mm Adapter Ring
 (Mfr # LT35EX77 • B&H # LET35EX77) **1149.95**

Letus35 Extreme with 82 mm Adapter Ring
 (Mfr # LT35EX82 • B&H # LET35EX823) **1149.95**

Camera Mounts for the Letus 35 Extreme (specify) 59.95

MATTE BOXES

3x3" Rubber Shade Matte Boxes

Available in three versions, Cavision's 3x3" rubber shade matte boxes fit a large variety of cameras and lenses including both broadcast and Mini-DV. Ideal for use on smaller cameras and when mobility is required, they accept 3x3 filters of various types (glass, resin and Cokin-P, as well as one 105mm circular threaded filter) and feature two filter holders—one is stationary while the other filter holder rotates (up to 180°) to work with polarizers and special effect filters. They incorporate a 85mm back mount opening for use with the optional ARP series adapter rings (82, 77, 72, 62, 58 & 52mm) that will snap into the back-mount of the matte box; you can use them in combination with the step down rings to various diameters.

3x3 Matte Box (Mfr # MB385P • B&H # CAMB385P): ABS Plastic Back Mount, Clamp On**164.95**

3x3 Matte Box (Mfr # MB385M • B&H # CAMB385M): Metal Back Mount, Clamp On**199.95**

Wide 3x3 Matte Box (Mfr # MB385PW • B&H # CAMB385PW): ABS Plastic Back Mount, Clamp On**164.95**



4x4" Hard Shade Matte Boxes

Available with metal filter trays (M version) or ABS filter trays (A version), the 100mm back-mount MB410 series are lightweight 4:3 rigid shades designed to fit a large variety of cameras and lenses including both broadcast and Mini-DV. Features two filter stages—one is stationary while the rotating stage (up to 270°) allows you to work with polarizers and graduated filters.

4x4 Hard Shade Matte Box (Mfr # MB410H2A • B&H # CAMB410H2A): With Two ABS Filter Trays**289.95**

4x4 Hard Shade Matte Box (Mfr # MB410H2M • B&H # CAMB410H2M): With Two Metal Filter Trays**329.95**

4x5.65" Hard Shade Matte Box for 16:9

The 120mm back-mount opening MB4169H-2M & MB4169H-3M are extra wide 16x9 hard shade matte boxes that fit a large variety of cameras and lenses including both broadcast and Mini-DV. Must be used with a rods support system. Ideal for use with Cavision 15mm rods which allow for horizontal and vertical adjustment.

4x5.65" Hard Shade Matte Box for 16:9 (Mfr # MB4169H2M • B&H # CAMB4169H2M): With 2 filter stages, one with 360° rotation (270° for FX1/Z1 cameras) and one with horizontal insertion and one 4x5.65" metal filter trays**379.95**

4x5.65" Hard Shade Matte Box for 16:9 (Mfr # MB4169H3M • B&H # CAMB4169H3M): With 3 filter stages: 2 with 360° rotation (270° for FX1/Z1 cameras) and one with horizontal insertion and one 4x5.65" metal filter trays**499.95**



4x5.65" Clamp-On Matte Box for 16:9

The 100mm back-mount opening MB4510-H2 is an extra wide 16x9 hard shade matte box that fits a large variety of cameras and lenses including both broadcast and Mini-DV. Designed for 16:9 shooting, it has one stationary holder that accepts 4x4" and 4x5.65 filters, and one rotating stage (up to 270°) for 4x4" polarizers and graduated filters. (The wider 4x5.65 filters are for 16:9 aspect ratios and HDTV).

4x5.65" Clamp-on Matte Box for 16:9 (Mfr # MB4510H2 • B&H # CAMB4510H2)**399.95**

MATTE BOXES

4x4" Bellows Matte Boxes

Highly affordable, the bellows adjustment allows for maximum flare protection. Available in two versions, they fit a large variety of cameras and lenses including both Broadcast and Mini-DV. Must be used with a rods support system. Ideal for use with Cavityon 15mm rods which allow for horizontal and vertical adjustment.

4x4 Bellows Matte Box (Mfr # MB413B2 • B&H # CAMB413B2)

Includes two metal filter stages, one with 360° degree rotation for use with polarizing and graduated filters and one with vertical insertion**399.95**

4x4 Bellows Matte Box (Mfr # MB413B3 • B&H # CAMB413B3M)

Includes three metal filter stages, two with 360° degree rotation for use with polarizing and graduated filters and one with vertical insertion**499.95**



5x5" Hard Shade Matte Boxes

Specifically designed for use with HDTV cameras, the MB5086H-2 is a 5x5" matte box with regular 16:9 hard shade and 2 metal filter stages (one fixed, one rotating). Multi-adjustable to fit a large variety of cameras and lenses, swing away feature allows easy lens access. Includes ARR1385 85mm rubber adapter ring already installed, and 15mm auxiliary rods for mounting other accessories.



MB565U3
5x5 Hard Shade
Matte Box

The MB565U-2 (2 metal filter stages, one fixed and one rotating) and MB565U-3 (3 metal filter stages, one fixed and two rotating) step-up with an extra wide hard shade, and more robust construction making it ideal for larger cameras. Also, grooved interior of the shade provides more absorption of extraneous light. The MB565U-2 includes one 5x5 metal tray, the MB565U-3 includes two, and both include a universal filter tray that holds 4x4", 4x5.65", 5x5" or 5.65x5.65" filters.

5x5 Hard Shade Matte Box (Mfr # MB565U2 • B&H # CAMB565U2): With extra large hard shade, one 5x5 metal filter tray and one universal metal filter tray (accepts 4x4", 4x5.65", 5x5" or 5.65x5.65" filters); Front filter stage: vertical insertion; back filter stages: 360° rotating; 19mm dia. / 105mm spaced rods support, film plate, and rubber adapter ring MBR110 are included.....**1089.95**

5x5 Hard Shade Matte Box (Mfr # MB565U3 • B&H # CAMB565U3S): With extra large hard shade, two 5x5 metal filter trays and one universal metal filter tray (accepts 4x4, 4x5.65, 5x5 and 5.65x5.65 filters). Front filter stage: vertical insertion; middle and back filter stages: 360° rotating; 19mm dia. / 105mm spaced rods support, film plate, and rubber adapter ring MBR110 are included**1529.95**

5x5 Hard Shade Matte Box (Mfr # MB5086H2 • B&H # CAMB5086H2S): With 16:9 hard shade and two 5x5 metal filter trays; Front filter stage: vertical insertion; back filter stage: 360° rotating; 15mm dia. / 100mm spaced rods support, film plate, and rubber adapter ring ARR1385 are included. Note: for use with Mini-DV cameras: 2nd version rear bracket with balance part, vertical part, and Mini-DV rods system plate (\$100 total) are also required**1059.95**



MB5086H2
5x5 Hard Shade
Matte Box



VFM-11X Micro Director's Viewfinder (Mfr# VFM11X • B&H# CADVFMZQ)

The VFM-11X allows a portable means of framing shots over various cinema standards, including 35mm or 16mm film, as well as video standards such as 1/3", 2/3" and 1/2". This model has an 11x zoom capability making it ideal for a wide range of focal lengths.....**199.95**

PRO SERIES

With over fifty years experience in lens design and manufacture—and numerous prestigious awards to its credit—Century Optics manufactures professional lenses and accessories used by filmmakers and videographers worldwide. Professional add-on lenses from Century Optics remove obstacles, expand creative choices, and make the seemingly impossible shot a reality. Century's Pro Series offers quality professional lens accessories designed to help you go wider, reach further, and move in closer than the lens on Sony PMW-EX1, HVR-V1 and HVR-Z1 HDV camcorders, JVC GY-HD110U, Panasonic AG-DVX100, AG-HVX200 and Canon XL-H1 lens alone allows. These state-of-the-art add-ons minimize chromatic aberrations and unwanted distortion and produce images that are ultra sharp edge-to-edge. Century's adapters and converters interface directly with the bayonet mount at the front of the lens so mounting and removing is quick and easy.



.55x and .6x HD Wide-Angle Adapters



Lightweight and cost-effective, the .55x W/A adapter instantly increases coverage by 45%, the .6x by 40%. Used for situations in which zooming isn't needed, the adapters allow zoom capability from wide angle to

mid-range in auto focus mode. Attached with a twist to the front of the video zoom lens, the .55x or .6x offer a significantly wider angle of view with minimal distortion.

.65x, .7x and .75x HD Wide-Angle Converters

The .65x, .7x and .75x W/A converters are ideal for shots which require both a wider angle of view and full zoom capabilities. They attach quickly to the front of the lens, offering a 35%, 30% and 25% (respectively) wider angle of view and full zoom-thru capabilities — with no appreciable light loss. Specially designed for HD applications with multi-layer coated glass elements. They come in a bayonet mount that attaches with a twist to the front of your lens. (No zoom on .7x for JVC GY-HD110U).



.8x HD W/A Converter



Compact and lightweight (half the size and weight of other wide angle attachments), the .8x HD Wide Angle Converter screws onto the front of a 72mm DV/HDV camera zoom lens, effectively shortening its focal length while maintaining full zoom

capabilities. Attach the compact converter to the front of a lens for 20% more coverage when set to wide angle, telephoto or anywhere in between. This can be especially advantageous when shooting in tight quarters. Comes with a rectangular sunshade and has a front filter thread of 86mm.

Fisheye HD Adapter



For a truly exaggerated point of view, twist on the Fisheye Adapter. The Fisheye gets you a wide view, with a non-vignetting fisheye look. Shoot the widest possible views and achieve extreme barrel distortion. Century's Fisheye exaggerates depth, pulling nearby

objects closer, and causing distant objects to recede into the background. A fixed adapter, the Fisheye doesn't allow for zooming — but you'll want to stay at the wide end of the range anyway, for the most pronounced effect.

.3x HD Ultra Fisheye Adapter

When you're shooting for a truly exaggerated point of view, twist on the .3x Ultra Fisheye Adapter. For the widest view possible with extreme barrel distortion, this non-zoom-thru add-on lens provides approximately 1.3mm focal length, 130° horizontal angle of view. (Note vignetting will occur at the extreme wide angle.)



Xtreme HD Fisheye



Designed specifically for the newer camcorders using the highest grade optics available, the Xtreme Fisheye lens offers the widest field of view with barrel distortion and a horizontal field of view of approximately 160° (180° to the corners). Applications include shooting action sports, underwater photography, music videos, or that dramatic impact shot in tight environments where

capturing the field of view is otherwise impossible. Lens attaches with a twist via the bayonet mount to the front of the lens.

PRO SERIES

1.6x Tele-Converter

Extend the reach of your zoom without exposure loss. The 1.6x Tele-Converter is a front mounted accessory that instantly shifts the focal length range of your camera in the telephoto direction. The perfect tool when it's inconvenient, dangerous, or even impossible to move as close to the subject as you'd like.



The 1.6x alters your zoom's focal length range by 1.6x with no appreciable light loss. (Note, the converter offers partial zooming, vignetting will occur at mid-range through full wide angle). Especially effective in "run-and-gun" shooting situations because it attaches quickly to the front of the existing lens with bayonet mount. For greater protection, it has 102mm thread for direct attachment of clear UV filters.

2x Tele-Converter

The 2x mounts to the camcorder lens front doubling focal length range while maintaining the lens' original F-stop at full telephoto. Multi-coated glass elements deliver ultra sharp images free of unwanted distortion or chromatic aberration. Bayonet mount, makes it quick and easy to securely mount to the front of the camcorder lens. Includes a lens support slider for mounting on standard 15mm support rods.



The 2x has a 105mm diameter front for compatibility with many shades, matteboxes and accessories. Also includes a lightweight round shade with a built-in rectangular mask to minimize flare and stray light. Offers partial zooming, with vignetting occurring at mid-range through full wide angle. For greater protection, it has 102mm thread screw-in filters.

	Panasonic AG-HVX200	Panasonic AG-DVX 100A/B	Sony HVR-V1U HDR-FX7	Sony HVR-Z1U HDR-FX1	Sony PMW-EX1	JVC GY-HD110U HD100U ¹	Canon XH-A1, XH-G1, and XL-H1	Canon XL-H1 ² XL-2 ³	Canon XL-2 ⁴ / JVC GY-DV5000U ⁵	Canon XL-2 with 3x Lens	JVC GY-DV500 & 65mm Zoom ⁶
.55x	—	—	HD-55WA-SH6 \$349.95	—	—	—	—	—	—	—	—
.6x	HD-06WA-HVX \$399.95	VS-06WA-DVX \$399.95	—	VS-06WA-HDS \$369.95	HD-06WA-EX1 \$399.95	—	HD-06WA-XLH \$399.95	HD-06WA-XLH \$399.95	VS-06WA-MXL CALL	HD-06WA-XLH \$399.95	VS-06WA-65 \$369.95
.65x	—	—	HD-65CV-SH6 \$499.95	—	—	—	—	—	—	—	—
.7x	—	VS-07CV-DVX \$699.95	—	VS-07CV-HDS \$729.95	—	OWA-7X93-00 \$449.95	—	VS-07CV-XL2 \$699.95	VS-07CV-MXL \$674.95	—	VS-07CV-65 \$658.50
.75x	HD-75CV-HVX \$994.95	—	—	—	HD-75CV-EX1 \$994.95	—	—	—	—	—	—
.8x	—	VS-08CV-72 \$519.95	VS-08CV-72 \$519.95	0VS-08CV-72 \$519.95	—	OWA-8XLC-00 \$879.95	VS-08CV-72 \$519.95	VS-08CV-72 \$519.95	VS-08CV-72 \$519.95	—	—
1.6x Tele-Converter	HD-16TC-HVX \$859.95	VS-16TC-DVX \$779.95	HD-16TC-SH6 \$739.95	VS-16TC-HDS \$859.95	HD-16TC-EX1 \$839.50	TC-16LC-85 \$849.95	0HD-16TC-XLH \$859.95	0HD-16TC-XLH \$859.95	VS-16TC-MXL \$808.50	—	VS-16TC-65 \$783.95
2.0x Tele-Converter	HD-20TC-HVX \$1299.95	HD-20TC-DVX \$1299.95	HD-20TC-SH6 \$1299.95	HD-20TC-HDS \$1299.95	—	—	—	—	—	—	—
Fisheye	HD-FESU-HVX \$524.95	VS-FEWA-DVX \$479.95	HD-FEAD-SH6 \$399.95	VS-FEWA-HDS \$499.95	HD-FESU-EX1 \$529.95	—	HD-FEAD-XLH \$499.95	HD-FEAD-XLH \$499.95	VS-FEWA-MXL CALL	HD-FEAD-XLH \$499.95	VS-FE65-00 \$499.95
.3x Ultra Fisheye	—	VS-FE3X-DVX \$788.50	HD-FE3X-SH6 \$879.95	VS-FE3X-HDS \$869.95	—	—	HD-FE3X-XLH \$812.50	—	—	—	—
Xtreme Fisheye	HD-FEWA-HVX \$2694.95	HD-FEWA-DVX \$2694.95	—	—	HD-FEWA-EX1 \$2694.95	—	—	—	—	—	—

1. With Fujinon TH16x5.5 zoom lens 2. With 20x zoom lens 3. With 20x/16x servo lens AF 4. With 16x manual lens 5. With Canon YH16x7 6. Detachable zoom lenses

	Canon GL-2, Sony DCR-VX2100, DSR-PD170, DSR-250 (Screw Mount)	Sony DCR-VX2100, DSR-PD170, DSR-250 (Bayonet Mount)	Canon GL-2 (Bayonet Mount)	Sony HVR-A1U, HDR-HC1
.55x	DS-55WA-58 \$289.95	---	---	DS-55WA-37 \$289.95
.65x	DS-65CV-58 \$439.95	DS-65CV-SB \$399.95	---	DS-HR65-37 \$229.95
16:9 Widescreen Adapter	---	---	---	DS-1609-37 \$249.95
.3x Ultra Fisheye	DS-FEWA-58 \$729.95	DS-FEWA-SB \$799.95	DS-FEWA-GL \$749.95	DS-FEWA-37 \$329.95
2x Tele-Converter	DS-20TC-58 \$399.95	DS-20TC-SB \$409.95	DS-20TC-GL \$409.95	DS-HR20-37 \$219.95

BROADCAST SERIES

Century Precision's tools enable creative videographers to capture imaginative new perspectives with their own zoom lens. By altering the optical characteristics of popular zooms, Century's tools dramatically expand their range and, therefore, usefulness. Many shots that would be impossible to execute or would require prohibitively expensive lenses are brought within easy reach by the right attachment.

IF Pro .8x Wide Angle Converter

The IF Pro .8x W/A Converter attaches quickly to the front of a zoom lens, effectively shortening its focal length while maintaining full zoom capabilities. Attach the .8x to the front of a lens for 20% more coverage when set to wide angle, telephoto or anywhere in between. For example, when added to an 7.8-172mm lens the .8x alters the focal range to 6.8-138mm. This can be especially advantageous when shooting in confined quarters. The .8x not only expands field of view, but also reduces minimum object distance (MOD). The camera can therefore move considerably closer to the subject while maintaining focus. Because there is no light loss with the IF Pro .8x Wide Angle Converter, there is no need to change exposure or lighting.

Complementing IF Broadcast, Pro and Pro Classic lenses both technically and aesthetically, the IF Pro .8x Wide Angle Converter is truncated on the top and bottom — for reduced weight, more practical shading, and access to a wide range of filtering options. It is also substantially lighter. The IF Pro .8x is only 18 oz. —30% less weight than the competition. Lighter means better balance for camera/lens combinations — a real benefit in handheld applications. And less stress on the focus mount of your lens.



IF Pro .8x Zoom-Thru W/A Converter for Canon and Fujinon 17x, 20x, 21x, and 22x HD/Broadcast Lenses (Mfr # 0WA-8XIF-20 • B&H # CEWA8XIF20).....**2266.50**

85mm Slip-on Adapter Ring (Mfr # 0FA-8X20-85 • B&H # CE0FA8X2085)**134.95**

86mm Slip-on Adapter Ring (0FA-8X20-86 • B&H # CE0FA8X2086)**139.95**

98mm Slip-on Adapter Ring (Mfr # 0FA-8X20-98 • B&H # CE0FA8X2098)**129.95**

100mm Slip-on Adapter Ring (Mfr # 0FA-8X20-00 • B&H # CE0FA8X2000)**129.95**

Sunshade (Mfr # 0FA-6XAS-20 • B&H # CE0FA6XAS20)**391.95**

Filter Holder Frame f/Sunshade (Mfr# 0FH-4565-00 • B&H# CE0FH456500) ..**205.95**

IF Pro 0.8x Zoom-Thru W/A Converter for Canon and Fujinon 15x and 16x Broadcast Lenses (Mfr # 0WA-8XIF-00; B&H # CEWA8XIF00)**1651.95**

85mm Slip-on Adapter Ring for above (Mfr# 0FA-8XIF-85 • B&H# CE0FA8XIF85)**119.95**

Sunshade (Mfr # 0FA-8XIF-00; B&H # CE0FA8XIF00)**379.95** Filter Holder Frame for Sunshade (Mfr# 0FH-4565-00 • B&H# CE0FH456500)**205.95**

WA-7X5X Wide Angle Adapter Set for HD/Broadcast Lenses (Non-Zoom)



Compact, lightweight and economical, the WA-7X5X Wide Angle Adapter Set consists of two lenses: the .7x Wide Angle and .5x Super Wide Angle. The .7x attaches to the front of the lens, increasing coverage by 30%. Adding the .5x to the .7x produces coverage nearly double that captured by the lens alone. (The .5x used alone increases coverage 30%.) For example, when attached to a lens that zooms to 9mm, the .7x W/A adapter shortens the effective focal length to 6.3mm. Adding the .5x Super W/A further alters the wide end of the lens to just 4.5mm, thus producing coverage nearly double that captured by the lens alone.

WA-7X93 0.7x (Mfr# 0WA-7X93-00 • B&H# CEWA7X9300): Wide-Angle Adapter**449.95**

WA-5X45 0.5x (Mfr# 0WA-5X45-00 • B&H# CEWA5X4500): Super Wide-Angle Adapter**499.95**

WA-7X5X 0.7x and 0.5x Wide Angle Adapter Set (Mfr# 0WA-7X5X-00 • B&H# CEWA7X5X00)

Includes WA-7X93 and WA-5X45 adapters - without Step-Up Rings**949.95**

85mm Slip-on Adapter Ring (Mfr # 0FA-8X20-85 • B&H # CE0FA8X2085)**134.95**

86mm Slip-on Adapter Ring (0FA-8X20-86 • B&H # CE0FA8X2086)**139.95**

98mm Slip-on Adapter Ring (Mfr # 0FA-8X20-98 • B&H # CE0FA8X2098)**129.95**

100mm Slip-on Adapter Ring (Mfr # 0FA-8X20-00 • B&H # CE0FA8X2000) ..**129.95**

Sunshade (Mfr # 0FA-6XAS-20 • B&H # CE0FA6XAS20)**391.95**

Filter Holder Frame f/Sunshade (Mfr# 0FH-4565-00 • B&H# CE0FH456500) ..**205.95**

BROADCAST SERIES

WA-FESU Super Fisheye Adapter

When you need the widest possible angle of view, the Super Fisheye Adapter produces an extraordinary degree of barrel distortion for a magnification factor of approximately .55x. For example, adding the Super Fisheye to a 15x8 lens results in a 116° horizontal angle of view — a remarkable 145° when measured diagonally.



◆ Tremendously wide field of view suggests a myriad of creative possibilities — from panoramic vistas that seem to stretch to the edge of the earth, to comical forced perspective close-ups in which an actor's distorted features seem to pop through the video screen. While extreme telephoto shots tend to flatten the subjects against the background, the Super Fisheye exaggerates depth, pulling nearby objects closer and causing distant objects to recede into the background.

◆ Due to the Super Fisheye's characteristic barrel distortion, extreme low and high angle shots are also made more dramatic. An attic crawl-space can induce heightened claustrophobia, or tall skyscrapers can be made to bend menacingly over the audience. And since the Super Fisheye takes in a much wider angle of view than the human eye, it can also be used to plunge the audience into a scene — surrounding them with a noisy crowd, or exiling them to a lonely beach.

WA-FESU-20 Super Fisheye Adapter for Canon and Fujinon 20x, 21x and 22x IF Broadcast Lenses (Mfr# 0WA-FESU-20 • B&H# CEWAFESU20) **1447.50**



1.6x Tele-Converter

Century's 1.6x Tele-Converter is an excellent way to extend the reach of your zoom. It attaches quickly to the front of the lens, shifting focal length range in the telephoto direction. Unlike internal and external tele-extenders, the 1.6x Tele-Converter requires no exposure compensation.

Adding the 1.6x to a 15x8 f/1.7-2.0 zoom alters its working focal length from 8-120mm to 120-192mm. (At focal lengths shorter than 120mm, vignetting occurs). Combining the 1.6x with a zoom's built-in 2x extender results in the longest possible reach - along with full zoom-through capabilities and no additional light loss. Engaging the

internal 2x extender converts an 8-120mm f/1.7 zoom lens into a 16-240mm f/3.4, with a two-stop loss of light. Mount a 1.6x Tele-Converter onto the front of the lens and the resulting focal length range is an astounding 26-384mm f/3.4.

OHD-16TC-SH6 1.6x Telephoto Converter Lens for Sony HVR-V1U and HDR FX7 (Zoom Through) (Mfr# 0HD-16TC-SH6 • B&H# CEHD16TCSH6) **859.95**

1.6x Telephoto Converter Lens for Panasonic HVX200 (Zoom Through) (Mfr# 0HD-16TC-HVX • B&H# CEHD16TCHVX) **859.95**

1.6x Telephoto Converter Lens for Sony HDR-FX1 & HVR-Z1U (Mfr# 0VS-16TC-HDS • B&H# CEVS16TCHDS) **859.95**

VS-16TC-XL 1.6x Tele-Converter Lens - for Canon XL-1 DV Camcorder (Bayonet Mount) (Mfr# 0HD-16TC-XLH • B&H# CEHD16TCXLH) **859.95**

2x Tele-Extenders

In situations where it is difficult, dangerous or even impossible to move in close, Century's 2x Tele-Extenders are the ideal solution. Easily mounting between your camera and lens, they double your lens' focal length, allowing you to fill the frame with far-away action. Model SF-213B fits most 1/3" bayonet mount lenses, the XF-212B fits most 1/2" bayonet mount lenses, and the XF-223B is for 2/3" bayonet mount lenses. With a 2x Tele-Extender, subjects that were previously out of range will now fill the frame. Get a shot across a stadium or over water. Attaching easily, the 2x instantly converts a 9-144mm 16:1 zoom lens into a 18-288mm super telephoto zoom. One caveat though, doubling the focal length results in a two-stop reduction in the amount of light reaching the focal plane. Characterized by their shallow depth-of-field, they also make it easy to isolate a subject from foreground and background. For example, wildlife videographers find this helpful when shooting an animal whose natural camouflage causes it to blend with its surroundings. Reduced depth-of-field is also effective in shooting past visual barriers, such as chain-link fences.



Zoom lens set at telephoto without Tele-Extender



With 2x Tele-Extender

2x Tele-Converter Lens for Panasonic AG-DVX100A and AG-DVX100 (Mfr# 0HD-20TC-DVX • B&H# CEHD20TCDVX) **1299.95**

2x Tele-Converter Lens for Sony HDR-FX1 & HVR-Z1U (Mfr# 0HD-20TC-HDS • B&H# CEHD20TCHDS) **1299.95**

2x Tele-Converter Lens for Panasonic HVX200 (Mfr# 0HD-20TC-HVX • B&H# CEHD20TCHVX) **1299.95**

ACHROMATIC DIOPTERS

Macro Zoom Attachments

Century's advanced two-element Achromatic Diopters turn zoom lenses into a true macro zoom. Also known as Macro Zoom Attachments, they allow more close-up range and magnification, while maintaining full zoom capabilities — without compromising image quality. They are also designed to maintain a flat field and edge-to-edge sharpness without chromatic aberration or image degradation.



- ◆ They provide dramatically shorter MOD (Minimum Object Distance)—essential when focusing tight on a small subject with a long lens — in tabletop, miniature and flat field videography. For example, add a +2.6 diopter to a 14x lens with an MOD of 40", and bring it down to 10", filling the frame with a subject as small as 3/4" across.
 - ◆ Reduced working distance also offers a wide range of shooting possibilities. Record exceptionally crisp footage of small objects like jewelry or computer chips. Industrial applications like remote high-magnification visual inspection of hard-to-reach objects and manufacturing processes are also made simpler.
 - ◆ Common single element diopters permit focusing at close camera-to-subject distances, only at the expense of image clarity. Instead, Century's Diopters feature two highly corrected glass elements for edge-to-edge sharpness, thus minimizing chromatic aberration and distortion.
- | | | | |
|---|-----------------|--|---------------|
| 37mm +2.5 Achromatic Diopter with 27, 30 and 30.5mm Step-up Rings.
(Mfr # 0AD-3725-00 • B&H # CE0AD372500)..... | 119.95 | 86mm +2.0 (Mfr # 0AD-8620-00 • B&H # CEAD8620) | 472.50 |
| 58mm +2.0 (Mfr # 0AD-5820-00 • B&H # CEAD5820) | 178.50 | 86mm +2.6 (Mfr # 0AD-8626-00 • B&H # CEAD862600) | 499.95 |
| 58mm +4.0 (Mfr # 0AD-5840-00 • B&H # CEAD5840) | 239.95 | 67-86mm Step-Up Ring (Mfr # 0FA-6786-00 • B&H # CEFA6786) | 78.95 |
| 58mm +7.0 (Mfr # 0AD-5870-00 • B&H # CEAD5870) | 229.50 | 72-86mm Step-Up Ring (Mfr # 0FA-7286-00 • B&H # CEFA7286) | 78.95 |
| Step-up rings from 37, 43, 46, 49, 52 and 55mm to 58mm | ea. 9.50 | 75mm Slip-on to 86mm Ring (Mfr # 0FA-7586-00 • B&H # CEFA7586)..... | 84.50 |
| 72mm+2.0 (Mfr # 0AD-7220-00 • B&H # CEAD7220) | 351.95 | 77-86mm Step-Up Ring (Mfr # 0FA-7786-00 • B&H # CEFA7786) | 79.95 |
| 72mm +3.5 (Mfr # 0AD-7235-00 • B&H # CEAD7235) | 332.95 | 80mm Slip-on to 86mm Ring (Mfr # 0FA-8086-00 • B&H # CEFA8086)..... | 84.50 |
| 62-72mm Step-Up Ring (Mfr # 0FA-6272-00 • B&H # CEFA6272)..... | 38.50 | 82-86mm Step-Up Ring (Mfr # 0FA-8286-00 • B&H # CEFA8286FA-8586) | 89.95 |
| 67-72mm Step-Up Ring (Mfr # 0FA-6772-00 • B&H # CEFA6772) | 38.50 | 85mm Slip-on to 86mm Ring (Mfr # 0FA-8586-00 • B&H # CEFA8586)..... | 79.50 |
| | | 90mm Slip-on to 86mm Ring (Mfr # 0FA-9086-00 • B&H # CEFA9086)..... | 79.95 |

Optical Adapters

All Adapters allow Infinity Focus

- 2/3" Bayonet Mount to C-Mount Adapter**
(B&H # CELA23BC).....**409.95**
- 2/3" Bayonet-Mount to Sony 1/2" Bayonet-Mount** (B&H # CELA23S5)
- 409.95**
- Nikon to 1/2" Bayonet Mount Adapter**
(B&H # CELAN120)
- 586.50**
- Nikon to Sony 1/2" Bayonet Mount Adapter** (B&H # CELANS50)
- 577.95**
- 1/2" CCD Sony Bayonet Mount to C-Mount Adapter** (B&H # CELA12SC)
- 409.95**
- 2/3" Bayonet Mount to 1/2" Bayonet Mount Adapter** (B&H # CELA2312).....
- 408.50**
- 1/2" Bayonet Mount to C-Mount Adapter**
(B&H # CELA12BC0)
- 406.95**

DVX-100A/B Accessories



Cine-Style Markable Manual Focus Ring

This smart accessory VS-MFSY-DVX is a user-markable white Delrin focus scale and witness mark that ensure accurate and repeatable focusing. This device clamp mounts over the existing focus scale of the Panasonic DVX-100A/B without camera modification. A lock-out mechanism limits the lens' focus range to 3'-Infinity with hard limit stops. A pitch follow-focus gear is

included to allow integration with cine style follow-focus systems.

VS-MFSY-DVX Cine Style Markable Manual Focus Ring - for DVX-100 Camcorder

(Mfr # OVS-MFSY-DVX • B&H # CEVSMFSYDVX).....**249.95**

Widescreen Eyepiece Adapter

Widescreen Eyepiece allows viewing of a 'normal' (unsqueezed) image when shooting with Panasonic's 16:9 optical anamorphic attachment (or the squeeze feature in the DVX100A). No modification needed, slips on the camera's existing finder and locks down with one lock screw.

VSL-CWS-DVX Wide Screen LCD Magnifier for AG-DVX-100/A

Camcorder. (Mfr # OVS-LCWS-DVX • B&H # CEVSLCWSDVX)

239.95



SUNSHADE/FILTER HOLDERS

Century offers a growing line of sunshade/ filterholders and specialty filters for a broad range of DV and HDV cameras. These products offer a compact and cost-effective means of adding creative capabilities to existing cameras.

DV Series Rectangular Sunshade/4x4" Filterholder

Ideal filtering solution for Mini DV camcorders like the Canon GL-2, Sony's DCR-PD170/VX-2100 and similar size camcorders. Works with DV series wide angle adapters that are made for the DV camcorders but, with a step up shade adapter will work directly on the camera itself. Accepts two 4x4" glass filters. (Mfr# ODS-FH44-00 • B&H# CEDSFH44).....**369.95**

Wide Angle Sunshade/4x4" Filterholder

Designed for use with the .7X HD Wide Angle Converter. This lightweight, 105mm clamp-on sunshade is a cost effective means of light management for Sony HDV and Panasonic's HVX-200 camcorders. Offers a provision for one 4x4" glass filter in a holder. Weighs only 6.5 oz. (Mfr# OVS-SS05-00 • B&H# CEVSS05)**159.95**

Pro Series Sunshade/4x4" Filterholder 4x4

Featuring a soft non-reflective round shade and an integral filterholder for up to two 4x4" glass filters. Ideal for cameras without internal focus lenses. (Mfr # OVS-FH44-00 • B&H # CEVSFH44)**399.95**



4x4" Filters for Video Production

Learn how to balance exposure, control depth of field, compensate for limited dynamic range, reduce glare, and control reflections with Century's Essential-5 Filter Kit. Created by the world's top maker of professional lens add-ons, these Century Filters by Schneider Optics have been specifically selected to meet the unique needs of today's DV/HDV cinematographers. The series of five filtration tools combines top-grade materials, high-end performance and affordability. The filters fit neatly into standard mattebox filterholders. The filters are available as a 5-filter kit with a multi-compartment padded pouch with belt-loop, or separately, in a hard plastic, designed for safe storage and protection.

Linear Polarizer Filter

The Polarizer reduces glare and unwanted reflections, saturates colors, deepens blue skies, improves contrast, and penetrates haze. Polarizers are commonly used to control glare on water and to allow the camera to see below the surface. They are also used to reduce glare on car bumpers and to control reflections on plate-glass windows.

Neutral Density .6 Filter

This solid filter has density of 0.6 (2 stops), which reduces transmission by 75%. Use to control exposure or depth of field under various lighting conditions without affecting color or contrast.

ND .6 Soft Edge Graduated Filter

Employs a surface that is 50% clear and 50% with a neutral density of 0.6. The shift from clear to ND is achieved with a soft edge transition line. The ND .6 Soft Edge Graduated Filter balances exposure within a scene – for example, the exposure of sky and earth in a landscape, avoiding overexposed blank white skies.

Black Frost 1/2 Diffusion Filter

For subtle enhancement of a scene, the Black Frost 1/2 Diffusion Filter may be used to flare highlights, mute colors, and tone down contrast, without degrading image quality or black saturation.

Skintone Enhancer Warming Filter

The Skintone Enhancer Warming Filter adds warmth to skin tones and accentuates foliage and architecture while reducing excessive blue in outdoor open shade. The ideal tool for romantic close-ups, it can be effectively combined with softening filters.

4x4 Linear Polarizer (Mfr # 68013044 • B&H # SCP44)**188.95**

4x4 ND .6 Solid (Mfr # 68040644 • B&H # SCND.644)**179.95**

4x4 ND.6 Solid Edge Grad (Mfr # 68050644 • B&H # SCGND.6S44)**209.95**

4x4 Black Frost 1/2 (Mfr # 68083244 • B&H # SCBF.544)**202.50**

4x4 Skintone Enhancer (Mfr # 68100044 • B&H # SCE44)**534.95**

DV MATTE BOX MKII

Compact & Wide Angle DV Matte Box MKII Systems for 4x4 Filters

Century offers the benefits of professional light control and filtering with the MKII Compact and Wide Angle DV Matte Box Systems. Precision engineered and manufactured of the finest materials, Century DV Matte Boxes are packed with creativity enhancing features and come equipped with everything needed for typical production. Matte Boxes allow you to control light better than a regular lens shade and offer the user the ability to use high quality 4x4 glass filters. The systems are ideal for use with Century add-on lenses up to 105mm O.D. They work with professional 4x4 glass filters, such as those from Tiffen and Schneider Optics (see previous page).



Compact DV Matte Box MKII

The Compact DV Matte Box accommodates mini DV cameras like Sony DSR-PD170, DSR-250, DCR-VX2100 and Canon GL-2/XL-1s/XL-2. Systems feature patented moveable eyebrows to reduce flare, 2 stages (1 fully rotatable, 1 fixed, two 4x4 filterholders, and an accessory shoe for light or microphone. Compact DV Matte Box MKII is available with 12mm cine-style rail or "quick-lock" clamp-on camera mounting system.

Compact DV Matte Box MKII with Cine-Style Rails

Complete Matte Box with adjustable eyebrows, plus 12mm rails with camera bracket for solid, adjustable support. The flexible Adapter Ring kit includes 6 interchangeable soft rubber rings for universal fit and lens safety. Includes alignment card and tool, and dust cover.

(Mfr # DSMB44KTC • B&H # CEDSMB44KTC) **1149.95**

Compact DV Matte Box MKII Clamp-on Kit

Compact DV Matte Box Clamp-on Kit attaches directly to the front of the camera lens (105mm O.D.) via a convenient "quick-lock" mechanism for ultra-compact & lightweight use. Includes 58-105 and 80-105mm adapter rings. (Mfr # DSMB44CCK • B&H # CEDSMB44CCK) **839.95**

Compact DV Matte Box MKII Clamp-on Kit

For Sony HRV-Z1U and HDR-FX1. Includes 72-105mm ring, Matte Box Dust cover, and two 4x4 filter frames. Doesn't work with Wide Angle Adapter. (Mfr # DSMB44HSC; B&H # CEDSMB44HSC) **899.95**

MFC-1 Manual Focus Controller Kit

A compact follow focus system designed for the Sony HVR-Z1U/HDR-FX1 and Panasonic HVX-200. With indefinite rotating focus rings in mind, the MFC-1 features a rotation-stopper. The "rotation stop" function gives the focus knob a manual-focus type feel for great precision, making the camera more focus repeatable. Made from machine aluminum and attaches to 15mm lightweight rods.

For HVX-200 (Mfr # 0HD-VMFC-HVX • B&H # CEHDVMFCHVX) **1448.95**

For HVR-Z1/HDR-FX1 (Mfr # 0HD-VMFC-HDS • B&H # CEHDVMFCHDS) **1424.50**

Wide Angle DV Matte Box MKII

The Century Wide Angle DV Matte Box is a full-size wide-angle hood Matte Box equipped with 1 fully rotatable and 1 fixed 4x4 filter stage and a French flag for reduced flare. Available with 15mm cine-style rail or "quick-lock" clamp-on camera mounting system.

Wide Angle DV Matte Box MKII with Cine-Style Rails

Complete system plus 15mm rails with camera bracket. Adapter Ring kit includes 6 interchangeable soft rubber rings for universal fit and lens safety. Compatible with accessories such as follow focus systems.

For Sony HVR-V1U, HDR-FX7, DCR-VX2100, DSR-PD170 and Panasonic HVX-200, DVX100A/B (Mfr # DSMB44WKT • B&H # CEDSMB44WKT) **1299.95**

For JVC GY-HD110U (Mfr # DSMB44JHD; B&H # CEDSMB44JHD) **1403.95**

For Sony HVR-Z1U, HDR-FX1 and Canon XH-A1/G1

(Mfr # DSMB44HSW • B&H # CEDSMB44HSW) **1403.95**

Wide Angle DV Matte Box Kit

With 15mm rod system—off-lens mounting for universal fit and lens safety. Includes French Flag. For Canon XL-2, XL-1s and XL-H1.

(Mfr # DSMB44XLW • B&H # CEDSMB44XLW) **1349.95**

Wide Angle DV Matte Box MKII Clamp-on Kits

These kits attach directly to the lens front (105mm O.D.) with Century's "quick-lock" mechanism for ultra-compact and lightweight use. Include French Flag and appropriate step-up rings.

For Sony HVR-V1U and HDR-FX7

(Mfr # ODS-MB44-W62 • B&H # CEDSMB44W62) **846.50**

For Panasonic HVX-200, JVC GY-HD110U (Mfr # ODS-MB44-WCK) **879.95**

For Canon XH-A1/XH-G1 (Mfr # ODS-MB44-W62) **846.50**

DV Matte Box Wide Angle Clamp-on Kit

With French Flag and 72, 80, 95 and 105mm clamp ring. It can be used on the Canon XL-2/XL-H1, and Panasonic DVX-100A/B with wide angle adapters.

(Mfr # ODS-MB44-CWK • B&H # CEDSMB44CWK) **876.95**

CHROSZIEL

4X4 SUNSHADE KITS

Chrosziel's 4x4 sunshade systems bring professional and affordable shading and filtering solutions to many of today's professional camcorders. Loaded with the benefits operators have come to expect from Chrosziel, they each include a housing that covers both 16:9 and 4:3, filter stage for two 4x4 filter holders (one rotating and one fixed) a full size French Flag for added light control, and the appropriate step down rings to fit your camcorder lens.

For a secure mount, it can be mounted onto 15mm lightweight supports with adjustable mattebox rods. A one-sided quick-lock mechanism anchors the sunshade system to the 15mm lightweight support with a simple twist of a knob. For authentic cine-style feel and function add Chrosziel's DV Studio rig follow focus (doesn't work on the XH-A1 and XH-G1).



Kits for Canon XH-A1 and XH-G1

Sunshade Kit 1 (Mfr # 44003XHA1K • B&H # CHDVSS44XH1K1): Includes Chrosziel 4x4 sunshade (440-03), French flag (402-28), filter stage for 2 filter holders, one rotating and one fixed filterholder (402-12), 104mm Rear Plate and 104:72mm step-down ring (411-14).....**719.95**

Sunshade Kit 2 (Mfr # 44003XHA1K2 • B&H # CHDVSS44XH2K2): Same as above, plus Center Bracket (420-02) and Lightweight Support (401-417).....**1169.95**

Kits for Canon XL-H1 and XL-2

Sunshade Kit 1 (Mfr # 44003XLH1K • B&H # CHDVSS44H1K1): Includes Chrosziel 4x4 sunshade (440-03), French flag (402-28), filter stage for 2 filter holders, one rotating and one fixed filterholder (402-12), 104mm Rear Plate and 104:72mm step-down ring (411-14).....**734.95**

Sunshade Kit 2 (Mfr # 44003XLH1K2 • B&H # CHDVSS44H1K2): Same as above, plus Center Bracket (420-02) and Lightweight Support (401-415).....**1349.95**

Sunshade Kit 3 (Mfr # 44003XLH1K3 • B&H # CHDVSS44H1K3): Same as Sunshade Kit 2, plus a DV Follow Focus (206-015), Focus Gear Drive (206-14), and a Focus Gear Ring (206-23)**2739.95**

Kits for JVC GY-HD100/250

Sunshade Kit 1 (Mfr # 44003HD100KIT • B&H # CHDVSS44HDK1): Includes Chrosziel 4x4 sunshade (440-03), French flag (402-28), filter stage for 2 filter holders, one rotating and one fixed filterholder (402-12), 104:85mm (411-23F) step-down adapter ring**874.95**

Sunshade Kit 2 (Mfr # 44003HD100KIT2 • B&H # CHDVSS44HDK2): Same as above, plus Center Bracket (420-02) and Lightweight Support (401-413).....**1159.95**

Sunshade Kit 3 (Mfr # 44003HD100KIT3 • B&H # CHDVSS44HDK3): Same as Kit 2, plus a DV Follow Focus (206-015), and Focus Gear Drive (206-16).....**2949.95**

Kits for Panasonic HVX-200

Sunshade Kit 1 (Mfr # 440-HVX200K • B&H # CHDVSS44HV1K1): Includes Chrosziel 4x4 sunshade (440-03), French flag (402-28), filter stage for 2 filter holders, one rotating and one fixed filterholder (402-12), 104:82mm (411-13) step-down adapter ring**874.95**

Sunshade Kit 2 (Mfr # 440-HVX200K2 • B&H # CHDVSS44HV2K2): Same as above, plus Center Bracket (420-02) and Lightweight Support (401-415).....**1349.95**

Sunshade Kit 3 (Mfr # 440-HVX200K3 • B&H # CHDVSS44HV3K3): Same as Kit 2, plus a DV Follow Focus (206-015), Focus Gear Drive (206-14), and a Focus Gear Ring (206-24)**3099.95**

Kits for Sony HVR-V1U and FX7

Sunshade Kit 1 (Mfr # 440-03HVRV1K1 • B&H # CHDVSS44V1K1): Includes Chrosziel 4x4 sunshade (440-03), French flag (402-28), filter stage for 2 filter holders, one rotating and one fixed filterholder (402-12), 104:62mm (411-15) step-down adapter ring**874.95**

Sunshade Kit 2 (Mfr # 440-03HVRV1K2 • B&H # CHDVSS44V1K2): Same as above, plus Center Bracket (420-02) and Lightweight Support (401-418).....**1349.95**

Sunshade Kit 3 (Mfr # 440-03HVRV1K3 • B&H # CHDVSS44V1K3): Same as Kit 2, plus a DV Follow Focus (206-015), Focus Gear Drive (206-14), and a Focus Gear Ring (206-25)**3099.95**

Kits for Sony HVR-Z1U and HDR-FX1

Sunshade Kit 1 (Mfr # 44003Z1K • B&H # CHDVSS44Z1K1): Includes Chrosziel 4x4 sunshade (440-03), French flag (402-28), filter stage for 2 filter holders, one rotating and one fixed filterholder (402-12), 104:85mm (411-23) step-down ring, 85:72mm (S1001-73) step-down ring**734.95**

Sunshade Kit 2 (Mfr # 44003Z1K2 • B&H # CHDVSS44Z1K2): Same as above, plus Center Bracket (420-02) and Lightweight Support (401-417)**1149.95**

Sunshade Kit 3 (Mfr # 44003Z1K3 • B&H # CHDVSS44Z1K3): Same as Kit 2, plus a DV Follow Focus (206-015), Focus Gear Drive (206-14), and a Focus Gear Ring (206-22).....**2499.95**

Kits for Sony PMW-EX1

Sunshade Kit 1 (Mfr # 440-EX1K • B&H # CHDVSS44EX1K): Includes Sony EX1 sunshade, French flag (402-28), filter stage for 2 filter holders, one rotating, one fixed filterholder (402-12), 104mm rear plate, 104:77mm (411-09) step-down ring**874.95**

Sunshade Kit 2 (Mfr # 440-EX1K2 • B&H # CHDVSS44EX2K2): Same as above, plus Center Bracket (420-02) and Lightweight Support (401-417)**1379.95**

MATTE BOXES

Chrosziel's Mattebox system brings professional shading and filtering solutions today's camcorders. Loaded with the benefits operators have come to expect from Chrosziel, features include a true 16:9 housing that covers both 16:9 and 4:3, filterstage for 2 filterholders (one 4x4 rotating and one 4x4/4x5.650 fixed), a full-size French flag, and the appropriate adapter rings. For a secure mount, the system comes with a center bracket and lightweight support with adjustable mattebox rods.

Chrosziel's efficient design includes many new operating advantages. The matteboxes are compatible with most wide and tele attachments. Dual pivot mechanisms are integrated into the housing for more cost efficient use of side wings. The system's articulating French flag can be teamed with optional side wings for precise manipulation of light. Protection against flare and loss of contrast is provided by a 16:9 insert mask. A one-sided quick-lock mechanism anchors the mattebox system to the 15mm lightweight support with a simple twist of a knob.

Each includes 16:9/4:3 Mattebox, 16:9 insert mask (450-MA), French Flag (450-11), 4x4 Rotating Filterstage including filter holder (402-12), 4x4/4x5.65 Fixed Filterstage including filter holder (410-04), Pivot Mechanism (use with optional side wings), 110mm Rear Plate, Lightweight Support System and appropriate step-down adapter ring.

For Canon XH-A1 and XH-G1: Same as above with Lightweight Support System (401-417) and 110:81mm (450-15) step-down adapter ring (Mfr # 450XHA1K • B&H # CHDVMB44XHA1)..... **1699.95**

For Canon XL-H1 and XL1: Same as above with Lightweight Support System (401-411) and 110:81mm (450-15) step-down adapter ring (Mfr # 450XLH1KIT • B&H # CHDVMB44XLH1)..... **1749.95**

For JVC HD-100/250: Same as above with Lightweight Support System (401-413) and 110:85mm (410-39) step-down adapter ring (Mfr # 450HD100KIT • B&H # CHDVMB44HDV1)..... **1699.95**

For Panasonic HVX-200: Same as above with Lightweight Support System (401-415) and 110:91mm (450-16) step-down adapter ring (Mfr # 450HVX200K • B&H # CHDVMB44HVK1)..... **1694.95**

For Sony HVR-V1U and HDR-FX7 Same as above with Lightweight Support System (401-418) and 110:91mm (450-15) step-down adapter ring (Mfr # 450V1KIT • B&H # CHDVMB44V1K1)..... **1699.50**

For Sony HVR-Z1U & HDR-FX1: Same as above with Lightweight Support System (401-417) and 110:91mm (450-15) step-down adapter ring (Mfr # 450HDVKIT • B&H # CHDVMB44HDK1)..... **1650.00**



B&H "Producer" Packages

These "Producer" packages include a host of critical accessories designed for aspiring producers looking to bring their acquisition methods to the next level. Kits include:



- ◆ Chrosziel 4x4 mattebox kit with French Flag, lightweight support with adjustable matte box rods and custom cover.
- ◆ 16x9 Inc. 0.75x wide angle conversion lens for HDV cameras. The lens features a multi-mount system with both 82mm and 72mm threads. There is a protective ring over the smaller diameter threads that is easily removed and replaced by the camera operator.
- ◆ Bebob Zoe-DVXL universal zoom controller featuring Maximum Speed Reduction (MSR) technology for much smoother slow zooms, a quick release clamp and click functions for switching quickly between manual and auto-focus
- ◆ 16x9's special "Grab and Shoot" soft case. This quick opening camcorder bag is made to hold a camcorder with a mattebox securely in place. The bag is made from an exterior layer of extra heavy duty waterproof Cordura that provides equipment protection and the contents are protected on all sides by layers of brightly colored cushioned fabric.

For the Sony HVR-V1U (B&H # 16PPHVRV1) **2649.00** For the Canon XH-A1 (B&H # 16PPXHA1) **2799.00**
 For the Sony HVR-Z1U (B&H # 16PPHVRZ1) **2699.00** For the Panasonic AG-HVX200 (B&H # 16PPHVX200) **3299.00**

CHROSZIEL

Chrosziel DV Follow Focus



The DV Studio Rig/Follow Focus was designed specifically for HDV/DV cameras — small and light weight. It is designed as a complete unit with a fixed handwheel; one-sided operation. It can only be used with lenses equipped with a focus gear ring.

- ◆ Mounts onto 15mm support rods
- ◆ Positionable indicator
- ◆ Marking scale
- ◆ Focus gear drive can be mounted on either side of follow focus
- ◆ Fits most lenses with proper focus gear drive
- ◆ Fits most DV/HDV cameras with proper focus gear drive and gear ring

DV Studio Rig/Follow Focus

(Mfr # 206015 • B&H # CH206015) **1689.95**

Gear Drives

Focus Gear Drive for Canon, Angenieux
(Mfr # 20610 • B&H # CH20610) **104.95**

Focus Gear Drive for Leica, Canon, Fujinon
cine-style (Mfr # 20612 • B&H # CH20612) **109.95**

Focus Gear Drive for Sony
(Mfr # 20614 • B&H # CH20614) **109.95**

Focus Gear Drive for Fujinon Lenses
(Mfr # 206-16 • B&H # CH20616) **104.95**



Gear Rings

Follow focus Gear Ring for AG-DVX100
(Mfr # 20620 • B&H # CH20620) **174.95**

Follow focus Gear Ring for Canon XL series
(Mfr # 20623 • B&H # CH20623) **174.95**

Follow focus Gear Ring for HVR-Z1U
(Mfr # 20622 • B&H # CH20622) **174.95**

Follow focus Gear Ring for HVX-200
(Mfr # 20624 • B&H # CH20624) **174.95**

Chrosziel DV Balancer

The DV Balancer by Chrosziel offers a comfortable method for supporting most small sized camcorders. Ideal for news broadcasts, sport events, documentaries, commercials or many other hand-held situations where stability is crucial and where the freedom to move is essential, the ergonomically designed DV Balancer is precision engineered and designed to support camcorders weighing up to 9 lbs.



- ◆ Designed to ergonomically conform to the operator's body, so when properly set-up, they'll be able to support the camcorder without the use of hands—reducing strain and fatigue. The weight of the camera will be absorbed by the shoulder pad and the abdomen leaving the hands free for controlling the camera.
- ◆ Easy-to-use, the DV Balancer can be adjusted vertically and horizontally to allow the user to view the viewfinder eyepiece. This is especially beneficial when using camcorders that have the viewfinder eyepiece on the back of the camera.
- ◆ Integrates seamlessly to most small sized camcorders with existing Chrosziel DV Lightweight Support systems. An optional camera adapter is available for cameras not equipped with the DV Lightweight support system.

DV Balancer Shoulder Brace (Mfr# AC-3000 • B&H# CHAC3000) **699.95**

DV Balancer Camera Adapter (Mfr # AC-3100 • B&H # CHAC3100)
Required when not using lightweight supports..... **188.95**

DV Balancer Universal Battery Holder (Mfr# AC-3200 • B&H# CHAC3200)
For Anton Bauer Gold Mount, IDX V-Plate, and PAG Lock battery systems..... **264.50**

DV Balancer Tripod Clamp (Mfr # AC-3220 • B&H # CHAC3220)
To mount the DV Balancer Battery Holder on a tripod..... **234.95**



FORMATT

FM-600 4x4 Matte Box

The FM-600 is a 4x4 matte box system designed for small DV/HDV cameras. Manufactured from aviation grade aluminum, the FM600 combines precision engineering with simplicity and ease of use for internal focus lenses. Adapters allow it to work with lens diameters from 43 to 82mm. It feature two fixed filter holders and one rotating 360° accommodating a wide range of filter combinations. The unit can work with or without the French flag; it even has the ability to remove the lens shade completely while still using the filter holders.

FM-600: With French Flag (Mfr # BFFM600MATT • B&H # FOMBFM600) **439.95**

4x4" HD/DV Outdoor Video Glass Filter Kit: Everything you need to shoot scenic and nature shots. Includes one HD Circular Polarizer, #1 Low Contrast, HD ND.6, Graduated HD ND .6 Soft Edge, HD/DV Soft Effects #3 and a filter pouch.
(Mfr# BF4KIT3 • B&H# FOHDDVOVFK44) **804.95**

MATTE BOXES

Hard Shade Matte Box Systems

Petroff's hard shade matte box systems are available in three basic sizes (4x4", 4x5" and 5x5") to fit a large variety of cameras and lenses including both broadcast and prosumer cameras. Matte boxes enable the user to add more control to the image; perfect for those videographers shooting film style and event shooters wanting to upgrade their image quality. These matte boxes accommodate three filter stages and can be mounted directly to the front barrel of the internal focus lens, or by using an optional support rod adapter, on a variety of bridge plates or support systems. All filter stages rotate 360° independently, but in order to operate comfortably with polarizing filters one or two stages could be blocked from rotation.

- ◆ With the unique Petroff snap-on filter stage system you get the ultimate when it comes to time and convenience.
- ◆ Fully modular, no-tools assembly system. You can add, remove or adjust all components of the system in seconds without the need of any tools.
- ◆ All stages rotate 360° independently, but you can block one or two from rotating
- ◆ The design of the Matte Box permits total freedom of movement of the filter holder in the horizontal and vertical planes.
- ◆ No-tools slide-in support adapter
- ◆ With the included Top French Flag, you can position it to cover the hard sunshade or at various angles depending on the user's application.
- ◆ Top and side flags fold inside shade profile for compact storage

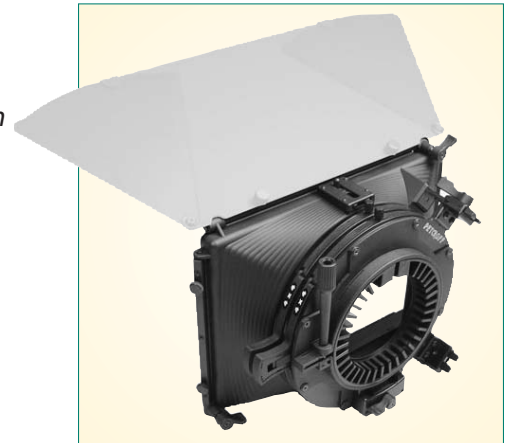

1-Stage 4x4 Hard Shade Matte Box Systems with Top Flag

(For lenses up to 110mm diameter and 3x3, 3x4, 4x4, 4x5, 4x5.65 and 4x6 filters)

4x4" Matte Box with 3x3" Rotating Filter Holder, 1-Filter Stage and 72mm Adapter Ring

(Mfr # P441R3372 • B&H # PEMB4413372)	1049.95
With 75mm Adapter Ring (Mfr # P441R3375 • B&H # PEMB4413375)	1049.95
With 80mm Adapter Ring (Mfr # P441R3380 • B&H # PEMB4413380)	1049.95
With 82mm Adapter Ring (Mfr # P441R3382 • B&H # PEMB4413382)	1049.95
With 85mm Adapter Ring (Mfr # P441R3385 • B&H # PEMB4413385)	1049.95
With 86mm Adapter Ring (Mfr # P441R3386 • B&H # PEMB4413386)	1049.95
With 90mm Adapter Ring (Mfr # P441R3390 • B&H # PEMB4413390)	1049.95
With 92mm Adapter Ring (Mfr # P441R3392 • B&H # PEMB4413392)	1049.95

4x4" Matte Box with 4x4" Rotating Filter Holder, 1-Filter Stage and 72mm Adapter Ring

(Mfr # P441R4472 • B&H # PEMB4414472)	1049.95
With 75mm Adapter Ring (Mfr # P441R4475 • B&H # PEMB4414475)	1049.95
With 80mm Adapter Ring (Mfr # P441R4480 • B&H # PEMB4414480)	1049.95
With 82mm Adapter Ring (Mfr # P441R4482 • B&H # PEMB4414482)	1049.95
With 85mm Adapter Ring (Mfr # P441R4485 • B&H # PEMB4414485)	1049.95
With 86mm Adapter Ring (Mfr # P441R4486 • B&H # PEMB4414486)	1049.95
With 90mm Adapter Ring (Mfr # P441R4490 • B&H # PEMB4414490)	1049.95
With 92mm Adapter Ring (Mfr # P441R4492 • B&H # PEMB4414492)	1049.95

4x4" Matte Box with 4x5" Rotating Filter Holder, 1-Filter Stage and 72mm Adapter Ring

(Mfr # P441R4572 • B&H # PEMB4414572)	1049.95
With 75mm Adapter Ring (Mfr # P441R4575 • B&H # PEMB4414575)	1049.95
With 80mm Adapter Ring (Mfr # P441R4580 • B&H # PEMB4414580)	1049.95
With 82mm Adapter Ring (Mfr # P441R4582 • B&H # PEMB4414582)	1049.95
With 85mm Adapter Ring (Mfr # P441R4585 • B&H # PEMB4414585)	1049.95
With 86mm Adapter Ring (Mfr # P441R4586 • B&H # PEMB4414586)	1049.95
With 90mm Adapter Ring (Mfr # P441R4590 • B&H # PEMB4414590)	1049.95
With 92mm Adapter Ring (Mfr # P441R4592 • B&H # PEMB4414592)	1049.95

4x4" Matte Box with 4x5.65" Rotating Filter Holder, 1-Filter Stage and 72mm Adapter Ring

(Mfr # P441R45P72 • B&H # PEMB44145P72)	1049.95
With 75mm Adapter Ring (Mfr # P441R45P75 • B&H # PEMB44145P75)	1049.95
With 80mm Adapter Ring (Mfr # P441R45P80 • B&H # PEMB44145P80)	1049.95
With 82mm Adapter Ring (Mfr # P441R45P82 • B&H # PEMB44145P82)	1049.95
With 85mm Adapter Ring (Mfr # P441R45P85 • B&H # PEMB44145P85)	1049.95
With 86mm Adapter Ring (Mfr # P441R45P86 • B&H # PEMB44145P86)	1049.95
With 90mm Adapter Ring (Mfr # P441R45P90 • B&H # PEMB44145P90)	1049.95
With 92mm Adapter Ring (Mfr # P441R45P92 • B&H # PEMB44145P92)	1049.95

MATTE BOXES

1-Stage 4x5 Hard Shade Matte Box Systems with Top Flag

(For lenses up to 110mm and 136mm diameter and 3x3, 3x4, 4x4, 4x5, 4x5.65 and 4x6 filters)

4x5" Matte Box with 3x3" Rotating Filter Holder,

- 1-Filter Stage and 95mm Adapter Ring
(Mfr # P451R3395 • B&H # PEMB4513395)**1349.95**
- With 98mm Adapter Ring (Mfr # P451R3398 • B&H # PEMB4513398)**1349.95**
- With 100mm Adapter Ring (Mfr # P451R33100 • B&H # PEMB45133100)**1349.95**
- With 105mm Adapter Ring (Mfr # P451R33105 • B&H # PEMB45133105)**1349.95**

4x5" Matte Box with 4x4" Rotating Filter Holder,

- 1-Filter Stage and 95mm Adapter Ring
(Mfr # P451R4495 • B&H # PEMB4514495)**1349.95**
- With 98mm Adapter Ring (Mfr # P451R4498 • B&H # PEMB4514498)**1349.95**
- With 100mm Adapter Ring (Mfr # P451R44100 • B&H # PEMB45144100)**1349.95**
- With 105mm Adapter Ring (Mfr # P451R44105 • B&H # PEMB45144105)**1349.95**

4x5" Matte Box with 4x5" Rotating Filter Holder,

- 1-Filter Stage and 95mm Adapter Ring
(Mfr # P451R4595 • B&H # PEMB4514595)**1349.95**
- With 98mm Adapter Ring (Mfr # P451R4598 • B&H # PEMB4514598)**1349.95**
- With 100mm Adapter Ring (Mfr # P451R45100 • B&H # PEMB45145100)**1349.95**
- With 105mm Adapter Ring (Mfr # P451R45105 • B&H # PEMB45145105)**1349.95**

4x5" Matte Box with 4x5.65" Rotating Filter Holder,

- 1-Filter Stage and 95mm Adapter Ring
(Mfr # P451R45P95 • B&H # PEMB45145P95)**1349.95**
- With 98mm Adapter Ring (Mfr # P451R45P98 • B&H # PEMB45145P98)**1349.95**
- With 100mm Adapter Ring (Mfr # P451R45P100 • B&H # PEMB45145P100)**1349.95**
- With 105mm Adapter Ring (Mfr # P451R45P105 • B&H # PEMB45145P105)**1349.95**

1-Stage 5x5 Hard Shade Matte Box Systems with Top Flag

Designed for the newest generation of extra wide film, video and HDTV lenses

(For lenses up to 136mm diameter and 4x4, 4x5, 4x5.65 and 4x6 filters)

5x5" Matte Box with 3x3" Rotating Filter Holder,

- 1-Filter Stage and 95mm Adapter Ring
(Mfr # P551R3395 • B&H # PEMB5513395)**1599.95**
- With 98mm Adapter Ring (Mfr # P551R3398 • B&H # PEMB5513398)**1599.95**
- With 100mm Adapter Ring (Mfr # P551R33100 • B&H # PEMB55133100)**1599.95**
- With 105mm Adapter Ring (Mfr # P551R33105 • B&H # PEMB55133105)**1599.95**
- With 120mm Adapter Ring (Mfr # P551R33120 • B&H # PEMB55133120)**1599.95**
- With 128mm Adapter Ring (Mfr # P551R33128 • B&H # PEMB55133128)**1599.95**
- With 130mm Adapter Ring (Mfr # P551R33130 • B&H # PEMB55133130)**1599.95**
- With 132mm Adapter Ring (Mfr # P551R33132 • B&H # PEMB55133132)**1599.95**

5x5" Matte Box with 4x4" Rotating Filter Holder,

- 1-Filter Stage and 95mm Adapter Ring
(Mfr # P551R4495 • B&H # PEMB5514495)**1599.95**
- With 98mm Adapter Ring (Mfr # P551R4498 • B&H # PEMB5514498)**1599.95**
- With 100mm Adapter Ring (Mfr # P551R44100 • B&H # PEMB55144100)**1599.95**
- With 105mm Adapter Ring (Mfr # P551R44105 • B&H # PEMB55144105)**1599.95**
- With 120mm Adapter Ring (Mfr # P551R44120 • B&H # PEMB55144120)**1599.95**
- With 128mm Adapter Ring (Mfr # P551R44128 • B&H # PEMB55144128)**1599.95**
- With 130mm Adapter Ring (Mfr # P551R44130 • B&H # PEMB55144130)**1599.95**
- With 132mm Adapter Ring (Mfr # P551R44132 • B&H # PEMB55144132)**1599.95**

5x5" Matte Box with 4x5" Rotating Filter Holder,

- 1-Filter Stage and 95mm Adapter Ring
(Mfr # P551R4595 • B&H # PEMB5514595)**1599.95**
- With 98mm Adapter Ring (Mfr # P551R4598 • B&H # PEMB5514598)**1599.95**
- With 100mm Adapter Ring (Mfr # P551R45100 • B&H # PEMB55145100)**1599.95**
- With 105mm Adapter Ring (Mfr # P551R45105 • B&H # PEMB55145105)**1599.95**
- With 120mm Adapter Ring (Mfr # P551R45120 • B&H # PEMB55145120)**1599.95**
- With 128mm Adapter Ring (Mfr # P551R45128 • B&H # PEMB55145128)**1599.95**
- With 130mm Adapter Ring (Mfr # P551R45130 • B&H # PEMB55145130)**1599.95**
- With 132mm Adapter Ring (Mfr # P551R45132 • B&H # PEMB55145132)**1599.95**

5x5" Matte Box with 4x5.65" Rotating Filter Holder,

- 1-Filter Stage and 95mm Adapter Ring
(Mfr # P551R45P95 • B&H # PEMB55145P95)**1599.95**
- With 98mm Adapter Ring (Mfr # P551R45P98 • B&H # PEMB55145P98)**1599.95**
- With 100mm Adapter Ring (Mfr # P551R45P100 • B&H # PEMB55145P100)**1599.95**
- With 105mm Adapter Ring (Mfr # P551R45P105 • B&H # PEMB55145P105)**1599.95**
- With 120mm Adapter Ring (Mfr # P551R45P120 • B&H # PEMB55145P120)**1599.95**
- With 128mm Adapter Ring (Mfr # P551R45P128 • B&H # PEMB55145P128)**1599.95**
- With 130mm Adapter Ring (Mfr # P551R45P130 • B&H # PEMB55145P130)**1599.95**
- With 132mm Adapter Ring (Mfr # P551R45P132 • B&H # PEMB55145P132)**1599.95**

MATTE BOXES



Systems for Sony

- 4x4 Matte Box with 1 Filter Stage and Top Flag for HDR-FX1 and HVR-Z1.
(Mfr # P441S • B&H # PEP441S)**889.95**
- Wide 4x4 Matte Box with 1 Filter Stage and Top Flag for HDR-FX1 and HVR-Z1.
(Mfr # P44-1-SW • B&H # PEP441SW)**918.95**
- 4x4 Universal Wide Angle Matte Box with 1 Filter Stage, with Top Flag for Sony HDR Series. (Mfr # P44-1-UW • B&H # PEP441UW)**918.95**
- 4x4 Matte Box with 2 Filter Stages and Top Flag for HDR-FX1 and HVR-Z1.
(Mfr # P442S • B&H # PEP442S)**964.95**
- 4x4 Matte Box with 3 Filter Stages and Top Flag for HDR-FX1 and HVR-Z1.
(Mfr # P443S • B&H # PEP443S)**1256.50**
- 4x4 Universal Wide Angle Matte Box with 2 Filter Stages and Top Flag, for Sony HDR Series. (Mfr # P44-2-UW • B&H # PEP442UW)**1293.95**
- 4x4 Wide Matte Box with 2 Filter Stages and Top Flag for HDR-FX1 and HVR-Z1.
(Mfr # P44-2-SW • B&H # PEP442SW)**1293.95**

Systems for Panasonic HVX-200

- 4x4 Wide Matte Box with Mini DV Bridge Plate, Top Flag, 1 Filter Stage, Insert for Panasonic HVX-200 (Mfr # PM44-1P • B&H # PEPM441P) ...**1382.95**
- 4x4 Wide Matte Box with Mini DV Bridge Plate, Top Flag, 2 Filter Stages, Insert for Panasonic HVX-200 (Mfr # PM44-2P • B&H # PEPM442P) ..**1682.95**

Wide Angle Systems for GY-HD110U

- W/A 4x4 Matte Box with 1 Filter Stage, Top Flag, Mini DV Universal Support and 86mm Ring (Mfr # P44J861K • B&H # PEP44J861K)**1376.95**
- Same as above except with 2 filter stages (Mfr # P44J862K • B&H # PEP44J862K)**1649.95**
- Same as above except with 3 filter stages (Mfr # P44J863K • B&H # PEP44J863K)**2129.95**

Systems for Canon

- 4x4 matte box with 4x4" rotating filter holder, 2 filter stages and 94mm ring for XL series with 20x Lens (Mfr # P44294 • B&H # PEP44294)**944.95**
- 4x4 matte box with 4x4" rotating filter holder, 2 filter stages and 89mm ring for XL series with 16x lens (Mfr # P44289 • B&H # PEP44289)**964.95**

System for Panasonic DVX100

- 4x4 Matte Box with SS-08 DV Universal Support and French Flag (Mfr # PETDVX124 • B&H # PEMB44DVX100)**1649.95**

MFF-01 Mini Follow Focus

The MFF-01 is follow focus for prosumer DV camcorders. The lightweight design works perfectly with Petroff's wide range of matte box and rod accessories, for seamless integration. The system features a marking ring to help perform precision focus-pulls. Also available in an economy version, the MFF-02.

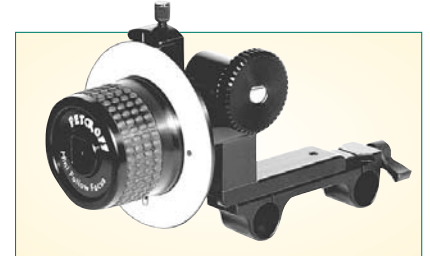

- MFF-01** (Mfr # MFF01 • B&H # PEMFF01)**1084.95**
- MFF-02** (Mfr # MFF02 • B&H # PEMFF02)**852.50**
- Focus Gear for the MFF-01 (Mfr # MFF03 • B&H # PEMFF03)**64.95**
- Lens Gear Ring for MFF-01 and MFF-02 (Mfr # MFF04 • B&H # PEMFF04)**109.50**
- HDR-FX1 Lens Gear Ring for MFF-01 and MFF-02 (Mfr # MFF-04S1 • B&H # PEMFF04S1)**107.95**
- AG-HVX200 Lens Gear Ring for MFF-01 and MFF-02 (Mfr # MFF-04P2 • B&H # PEMFF04P2)**107.95**
- Marking Ring for MFF-01 (Mfr # MFF05 • B&H # PEMFF05)**84.95**
- 0.8 Focus Gear for the MFF-01 (Mfr # MFF-08 • B&H # PEMFF08)**63.95**



TIFFEN FILTERFLEX

Precision Filter Control Box

Combining unique, patented innovations with maximum flexibility, Tiffen's FilterFlex lets you use almost any square or rectangular 4" wide filter to achieve beautiful images. Lightweight, it clamps directly to your lens without bulky support rails, and since no separate frames are required, filters go on and off quickly.

- ◆ Comes with 2 filter stages which rotate 360° independently and a rectangular lens shade that remains horizontal while rotating filters. It allows precise fingertip positioning of each filter independently.
- ◆ Hold one or two filters, or three with optional accessory.
- ◆ Fast on/off and swing away positions for easy access to front of the lens.
- ◆ Filters are held parallel to the lens, minimizing internal reflection problems.
- ◆ Accepts square or rectangular 4" wide by standard length (4 x 4", 4 x 5", 4 x 5.650", 4 x 6").

FilterFlex for external focus lenses up to 105mm in diameter (Mfr # FFEXT • B&H # TIFFE) ...**974.95**

French Flag Assembly for FilterFlex (Mfr # FFFASMBLY • B&H # TIFFA)**72.50**

80mm (#TIFFCR80), 85mm (#TIFFCR85), 90mm (#TIFFCR90), 95mm (#TIFFCR95) or 100mm (#TIFFCR100) C-Ring Adapter for FilterFlex**ea. 44.95**

FILTERS

Center Spot Filters

How often do you get just the background you want? Not often enough? Take a different approach to this distracting problem by softly diffusing only the background, leaving the area of central interest clear and sharp, with the Center Spot filter. The Warm Center Spot filter combines the benefits of the Center Spot with the added warmth of the 812 Filter.

Clear Filters

Helps protect your lens from dust, scratches, dirt, moisture, fingerprints and more, without affecting the color. Available in uncoated and coated.

Hot Mirror IR ND Filters

Unlike photographic film, the imaging devices in high definition cameras are very sensitive to infra-red light. Because of this, IR pollution has become a significant issue. Tiffen addressed this problem with their special Hot Mirror (HM) filter that completely blocks IR thru the entire spectrum with no appreciable reduction in visible light transmission. HM filters can be used individually or as a Hot Mirror IRND in one combination filter. Tiffen ColorCore technology sandwiches the coating within the filter for easy cleaning.



Without Filter



With Warm Center Spot

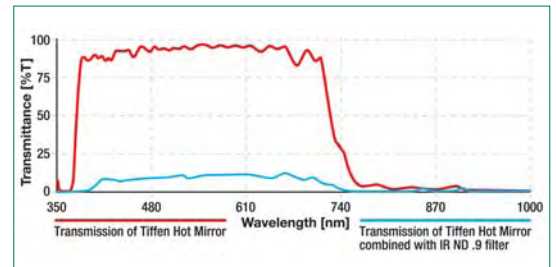

CENTER SPOT FILTERS							
	3" x 3"	4" x 4"	4" x 5.65"	5" x 6"	5" x 5"	5.65" x 5.65"	6.6" x 6.6"
Center Spot #TICS()	126.95	174.95	322.95	314.95	304.95	349.95	349.95
Warm Center Spot #TIWCS()	134.95	188.95	331.95	360.95	354.95	360.95	360.95

CLEAR FILTERS							
	3" x 3"	4" x 4"	4" x 5.65"	5" x 6"	5" x 5"	5.65" x 5.65"	6.6" x 6.6"
Clear Filter Uncoated #TICU()	64.95	96.95	154.95	228.95	185.95	205.95	205.95
Clear Filter Coated #TIC()	82.95	133.95	172.95	264.95	215.95	251.95	251.95

HOT MIRROR IR ND FILTERS							
Density:	0.30	0.60	0.90	1.2	1.5	1.8	2.1
105C Hot Mirror IR ND #W105CHMIRND	450.00	450.00	450.00	450.00	450.00	450.00	450.00
138mm Hot Mirror IR ND #W138HMIRND	585.00	585.00	585.00	585.00	585.00	585.00	585.00
4 x 4 Hot Mirror IR ND #W44HMIRND	337.50	337.50	337.50	337.50	337.50	337.50	337.50
4 x 560 Hot Mirror IR ND #W4560HMIRND	540.00	540.00	540.00	540.00	540.00	540.00	540.00
565 Hot Mirror IR ND #W565HMIRND	810.00	810.00	810.00	810.00	810.00	810.00	810.00

To order Center Spot or Clear filters, please fill in the parenthesis at the end of the SKU as follows: 3" x 3" (33), 4" x 4" (44), 4" x 5.65" (45P), 5" x 6" (56), 5" x 5" (55Q), 5.65" x 5.65" (565), and 6.6" x 6.6" (66).

When ordering Hot Mirror IR ND filters, specify density (0.03, 0.06, 0.90, 1.2, 1.5, 1.8, 2.1).

COLOR-GRAD FILTERS / COMPLEMENTS

Color-Grad Filters

Transform an average sunrise or sunset into something spectacular. Convert a dull, washed-out sky to a breathtaking blue. Color-Grad filters are used to make adjustments to the red, blue or green characteristics of light. Applications include correcting for color balance, light source variations, different reversal film batches, and other color effects. Half color, half clear, with a soft transition between, Color-Grads can best be used in a rotating mount or filter holder, for proper alignment in the image. Combine them to achieve more density.



Without Filter



With Color Grad Sunset

- ◆ Add color selectively while leaving the rest of the scene unaffected.
- ◆ Half color, half clear with a graduated density transition for smooth blending into the scene.
- ◆ Use in combination, with one affecting the upper half of the image, the other affecting the lower.

COLOR-GRAD FILTERS							
	3" x 3"	4" x 4"	4" x 5.65"	5" x 6"	5" x 5"	5.65" x 5.65"	6.6" x 6.6"
Blue #TIGBL()()()	151.95	199.95	317.95	424.95	371.95	424.95	424.95
Cool Blue #TIGCB()()()	151.95	199.95	317.95	424.95	371.95	424.95	424.95
Coral #TIGC()()()	151.95	199.95	317.95	424.95	371.95	424.95	424.95
Cyan #TIGC()()()Q	151.95	199.95	317.95	424.95	371.95	424.95	424.95
Green #TIGG()()()	151.95	199.95	317.95	424.95	371.95	424.95	424.95
Magenta #TIGM()()()	151.95	199.95	317.95	424.95	371.95	424.95	424.95
Pink #TIGP()()()	151.95	199.95	317.95	424.95	371.95	424.95	424.95
Red #TIGR()()()	151.95	199.95	317.95	424.95	371.95	424.95	424.95
Yellow #TIGY()()()	151.95	199.95	317.95	424.95	371.95	424.95	424.95
ND #TIGND()()()	151.95	199.95	317.95	424.95	371.95	424.95	424.95
Chocolate #TIGCH()()()	151.95	199.95	317.95	424.95	371.95	424.95	424.95
Cranberry #TIGCR()()()	151.95	199.95	317.95	424.95	371.95	424.95	424.95
Grape #TIGGP()()()	151.95	199.95	317.95	424.95	371.95	424.95	424.95
Plum #TIGPL()()()	151.95	199.95	317.95	424.95	371.95	424.95	424.95
SkyFire #TIGSF()()()	151.95	199.95	317.95	424.95	371.95	424.95	424.95
Sunset #TIGSS()()()	151.95	199.95	317.95	424.95	371.95	424.95	424.95
Straw #TIGST()()()	151.95	199.95	317.95	424.95	371.95	424.95	424.95
Tangerine #TIGT()()()	151.95	199.95	317.95	424.95	371.95	424.95	424.95
Tobacco #TIGTO()()()	151.95	199.95	317.95	424.95	371.95	424.95	424.95
Twilight #TIGTL()()()	151.95	199.95	317.95	424.95	371.95	424.95	424.95

Color-Grad Complements

Using a Color-Grad filter to add color to the sky can often look even better when a complementary tint is added to the foreground. Designed to be used together with a Color-Grad in this manner, or to add a bit of color interest on their own, Color-Grad Complements come in 3 color series: **Blue** for use with Tropic Blue, Cyan, Cool Blue, Grape, Blue and Twilight; **Red** for use with Plum, Magenta, Cranberry, Pink, Red, Skyfire, and Twilight; and **Amber** for use with Chocolate, Sepia, Coral, Tangerine, Tobacco, Straw, Antique Suede, Skyfire and Sunset. Each series comes in two grades, Grade 1 provides milder tones; Grade 2 is for more dramatic color.

COLOR-GRAD COMPLEMENTS							
	3" x 3"	4" x 4"	4" x 5.65"	5" x 6"	5" x 5"	5.65" x 5.65"	6.6" x 6.6"
Red #TICR()()Q	158.95	209.95	331.95	444.95	372.95	444.95	444.95
Amber #TICA()()Q	158.95	209.95	331.95	444.95	372.95	444.95	444.95
Blue #TICBL()()Q	158.95	209.95	331.95	444.95	372.95	444.95	444.95

Blue, Cool Blue, Cyan, Green, Magenta, Pink, Red and Yellow **Color Grad** filters are available in densities of 1, 2, 3, 4, and 5. Sunset, Straw, Chocolate, Cranberry, Grape, Plum, SkyFire, Tangerine, Tobacco, Tropic Blue and Twilight are available in densities of 1, 2, and 3. Coral is available in 1/8, 1/4, 1/2, 1, 2, 3, 4, and 5. ND is available in .3, .6, .9, and 1.2. You can also choose Soft or Hard for the degree of color transition. Insert the density # in the first parenthesis (18, 14, 12, .3, .6, .9, 1, 2, 3, 4, and 5); Soft (S) or Hard (H) gradation in the second parenthesis, and the filter size in the third parenthesis. **Color Grad Complement** are available in densities of 1 and 2. Please insert the density # in the first parenthesis and the filter size in the second parenthesis.

COMBINATION COLORS & POLARIZERS

Several filter combinations are so popular that they are produced as two filter effects in one. These include: Neutral Density or Polarizer plus 81 or 85 Wratten filters; the Polarizer plus ENHANCING filter; the Warm versions of Pro-Mist, Soft/FX, Black Pro-Mist filters, and others.

COMBINATION COLOR & POLARIZERS							
	3" x 3"	4" x 4"	4" x 5.65"	5" x 6"	5" x 5"	5.65" x 5.65"	6.6" x 6.6"
81EFN3 #TI81EFN.3()	126.95	174.95	332.95	330.95	316.95	349.95	349.95
81EFN6 #TI81EFN.6()	126.95	174.95	332.95	330.95	316.95	349.95	349.95
81EFN9 #TI81EFN.9()	126.95	174.95	332.95	330.95	316.95	349.95	349.95
85N3 #TI85ND.3()	126.95	174.95	332.95	330.95	316.95	349.95	349.95
85N6 #TI85ND.6()	126.95	174.95	332.95	330.95	316.95	349.95	349.95
85N9 #TI85ND.9()	126.95	174.95	332.95	330.95	316.95	349.95	349.95
85N12 #TI85ND1.2()	126.95	174.95	332.95	330.95	316.95	349.95	349.95
85BN3 #TI85BN.3()	126.95	174.95	332.95	330.95	316.95	349.95	349.95
85BN6 #TI85BN.6()	126.95	174.95	149.95	330.95	316.95	349.95	349.95
85BN9 #TI85BN.9()	126.95	174.95	322.95	330.95	316.95	349.95	349.95
85BN12 #TI85BN1.2()	126.95	174.95	332.95	330.95	316.95	349.95	349.95
85 Linear Polarizer #TI85P()	126.95	174.95	372.95	351.95	337.95	350.95	350.95
85B Linear Polarizer #TI85BP()	126.95	174.95	372.95	351.95	337.95	350.95	350.95
85 Ultra Pol Circular Polarizer #TI85UCP()	249.95	292.95	416.95	454.95	440.95	473.95	473.95
85B Ultra Pol Linear Polarizer #TI85UP()	162.95	204.95	339.95	360.95	381.95	407.95	407.95



Without Filter



With Ultra Contrast 3

Contrast Control Filters

Low Contrast: When the sun is too bright and the shadows too dark, you can't get good detail in both at the same time. Low Contrast filters gently flare highlights to add some detail to the shadows, for a more pleasing image. The various densities can finely tune contrast, or create an almost pastel-like color desaturation.

Soft Contrast: Like Low Contrast, but with a one-stop neutral density filter added. Without exposure-compensating, this will reduce excess highlight brightness, and subtly lighten shadows, while allowing you to maintain your lens setting for more consistent sharpness and depth-of-field.

Ultra Contrast: Get control over harsh lighting. The Ultra Contrast filter allows the image to render more detail in the shadows without causing any flare or halo effect from bright light sources, reflections or highlights. It uses ambient scenic light to lower contrast evenly throughout the whole scene, while maintaining critical sharpness throughout.

Low Light Ultra Contrast: All the effects of the Ultra Contrast filter, for use in low light situations.

	3" x 3"	4" x 4"	4" x 5.65"	5" x 6"	5" x 5"	5.65" x 5.65"	6.6" x 6.6"
Low Contrast #TILC()()	113.95	170.95	274.95	350.95	314.95	350.95	350.95
Soft Contrast #TISC()()	113.95	170.95	274.95	350.95	314.95	350.95	350.95
Ultra Contrast #TIUC()()	135.95	199.95	327.95	417.95	373.95	417.95	417.95
Low Light Ultra Contrast #TILLUC()()	113.95	199.95	327.95	417.95	373.95	417.95	417.95

To order **Combination Color & Polarizers**, please fill in the parenthesis at the end of the SKU as follows: 3" x 3" (33), 4" x 4" (44), 4" x 5.65" (45P), 5" x 6" (56), 5" x 5" (55Q), 5.65" x 5.65" (565), and 6.6" x 6.6" (66). To order **Contrast Control** filters, put a * in the first parenthesis and the shade size in the second parenthesis.

FILTERS

Day-for-Night

Get the appearance of night while shooting in daylight. These filters offer an easy and cost-effective way to create a realistic dusk or nighttime appearance when filming during the day.



Without Filter



With Day-for-Night

They will save the expense of what might be extensive lighting needed for large areas when actually shooting at night, instead

of making use of available sunlight. Use the Cool Day-for-Night for a blue moonlight. Monochrome Day-for-Night is used with subsequent color timing to create a more “silvery-moon” effect.

Decamired

Takes the guesswork out of determining color temperature. Acts as a conversion filter for color temperature adjustments from any point to any other point in the color temperature scale. Can be used to create “proper” coloration in unusual situations, and to make creative alterations. Applications include keeping color temperature constant during the course of the day and producing the effect of different times of day. Available in two series, reddish filters that warm the light and bluish filters that cool the light. Each series contain 4 densities: 1/2, 3, 6 and 12.

Coral

Many densities of a warming color similar to the Wratten 85. Used to maintain a consistent color outdoors throughout the day, to extend shooting hours, or to make creative variations.



Diffusion/FX Filters

Black Diffusion/FX gives a silky-smooth look to textured surfaces; suppresses facial blemishes and wrinkles while maintaining a clear, overall in-focus image. Produces a minimum of high-light flare that would otherwise signal the presence of a filter. Comes in Black or Gold series, each available in several grades. Gold Diffusion/FX is them same while adding a soft, golden tint to shadows and infuses images with special warmth. Warm Black Diffusion/FX offers the same benefits as Black Diffusion/FX with the added warmth of the 812 filter. (The 812 is the ideal “cosmetic skin tone enhancer”).



◀ Top to bottom: Diffusion/FX 1, 2, 4, and 5

CORAL, DAY-FOR-NIGHT, DECAMIRED & DIFFUSION/FX FILTERS

	3" x 3"	4" x 4"	4" x 5.65"	5" x 6"	5" x 5"	5.65" x 5.65"	6.6" x 6.6"
Coral #TIC() ()	113.95	171.95	274.95	350.95	314.95	350.95	350.95
Day-for-Night Cool #TIDFNC()	157.95	209.95	320.95	443.95	388.95	443.95	443.95
Day-for-Night Monochrome #TIDFNM()	157.95	209.95	320.95	443.95	388.95	443.95	443.95
Decamired Blue #TIDMBL() ()	113.95	169.95	274.95	351.95	374.95	349.95	349.95
Decamired Red #TIDMR() ()	113.95	169.95	274.95	351.95	374.95	349.95	349.95
Decamired Blue Set of 4 #TIDMBLS()	365.95	547.95	881.95	1123.95	923.95	1123.95	1123.95
Decamired Red Set of 4 #TIDMRS()	365.95	547.95	881.95	1123.95	923.95	1123.95	1123.95
Black Diffusion/FX #TIBDFX() ()	157.95	332.95	376.95	481.95	402.95	481.95	481.95
Warm Black Diffusion/FX #TIWDFX() ()	157.95	332.95	376.95	481.95	402.95	481.95	481.95
Gold Diffusion/FX #TIGDFX() ()	157.95	332.95	376.95	481.95	402.95	481.95	481.95

To order **Coral**, **Decamired** and **Diffusion/FX** filters, put a * in the first parenthesis and the shade size in the second parenthesis.

To order **Decamired Sets** and **Day-for-Night** filters, put the shade size in the parenthesis.

FILTERS

Enhancing

The Enhancing filter creates warm vibrant color by selectively improving saturation of reds and oranges, with minimum effect on other colors.

A "must have" for fall foliage, and for getting the greatest color "punch" from warm-tones, such as brick and barn reds and oranges.



Without Filter



With Enhancing Filter

Fluorescent Light Color Correction



Without Filter



With Fluorescent Filter

For more natural color, eliminating the green cast under average fluorescent lighting. The FL-B filter is for use with tungsten film or video cameras

set for tungsten balance. The FL-D filter is for use with the daylight film or video cameras set for daylight balance.

LL-D: Allows use of tungsten film in low-light without exposure compensation. For use with negative film for motion picture photography in conjunction with an optical printer.

Glimmerglass

Glimmerglass diffusion filters soften fine details and add a mild glow to highlights. As contrast is also reduced, the look is one of enhanced beauty. The filter has a distinct silver 'sparkle', which has been found to be doubly useful. When production starts and people see the filter 'glittering' on the front of the lens, they become more confident in the knowledge that the filter is working for them.



Without Filter



With Glimmerglass 5 Filter



Without Filter



With Double Fog 3

Fog Effects

Fog filters mimic the effect of natural fog, creating a soft glow and flare and produce a warm romantic tone. They make highlights glow and "mist" appear where none previously existed. Double Fog filters have milder flare and softening characteristics than standard Fog filters while exhibiting a much greater effect on contrast.

ENHANCING, FLUORESCENT LIGHT COLOR CORRECTION, GLIMMERGLASS AND LL-D FILTERS							
	3" x 3"	4" x 4"	4" x 5.65"	5" x 6"	5" x 5"	5.65" x 5.65"	6.6" x 6.6"
Enhancing #TIE()	215.95	355.95	451.95	504.95	479.95	504.95	504.95
Enhancing Ultra Pol Circular Pol #TIEUCP()	397.95	427.95	549.95	657.95	615.95	660.95	660.95
Enhancing Ultra Pol Linear Pol #TIEUP()	355.95	374.95	531.95	634.95	582.95	610.95	610.95
FL-D Daylight #TIFLD()	113.95	169.95	274.95	351.95	314.95	349.95	349.95
FL-B Tungsten #TIFLB()	113.95	169.95	274.95	351.95	314.95	349.95	349.95
Fog #TIF()()	113.95	169.95	274.95	351.95	314.95	349.95	349.95
Double Fog #TIDF()()	113.95	169.95	274.95	351.95	314.95	349.95	349.95
Glimmerglass #TIGG()()	135.95	199.95	327.95	417.95	373.95	417.95	417.95
LL-D #TILLD()	127.95	169.95	274.95	350.95	299.95	349.95	349.95

To order **Fog and Glimmerglass** filters, put a * in the first parenthesis and the shade size in the second parenthesis.

To order **Enhancing, FL-D and FL-B** filters, put the shade size in the parenthesis.

FILTERS

Neutral Density Filter

Neutral Density filters reduce the amount of light passing through the camera lens without changing the color of the scene. They are especially useful in brightly lit conditions to help prevent overexposure. For example, they allow cine and video cameras (which have fixed shutter speeds) to film subjects such as snow, sand or other bright scenes without the worry of overexposure.

Neutral Density filters are available in densities from .1, .2, .3, .4, .5, .6, .7, .8, .9, 1.0, and 1.2. **ND White Water** filters, which are made from a premium high-quality optical glass with fewer impurities, are available in densities of .3, .6, .9, and 1.2.



Without Filter



With Neutral Density Filter

Polarizing Filters

Polarizing filters reduce glare and reflections, saturate colors and darken blue skies.

They are particularly ideal when photographing into water or through glass to reduce reflections.

The polarizer can be rotated to determine the degree of reflection reduction. For

outdoor scenes, rotate the polarizer to change blue sky densities from light to dark, creating dramatic contrast between sky blue and cloud white.



Without Filter



With Warm Polarizer

Linear Polarizers are the standard version for non-autofocus still cameras or camera systems without internal polarizing optics. Also available as Warm Linear.

Low Light Polarizers were developed for shooting indoors in low-light conditions and for situations that do not provide enough light for a standard polarizer to be used. Also available as Warm Low Light.

Circular Polarizers are designed for all cameras, but especially still cameras with autofocus, or others with "beam splitting" internal optical systems, like using a video tap. The circular polarizer works just like the linear, except that it doesn't adversely affect the function of these systems.

Ultra Pol Polarizers are the highest polarization efficiency available. Maximum reduction of reflections and unwanted glare and for maximum color saturation. Available in Ultra Pol Linear, Warm Ultra Pol Linear, Ultra Pol Circular Polarizer and Warm Ultra Pol Circular.

NEUTRAL DENSITY & POLARIZING FILTERS

	3" x 3"	4" x 4"	4" x 5.65"	5" x 6"	5" x 5"	5.65" x 5.65"	6.6" x 6.6"
ND #TIND() ()	90.95	144.95	194.95	306.95	254.95	306.95	306.95
ND Water White Glass #TIND() ()W()	132.95	193.95	227.95	346.95	280.95	334.95	334.95
Linear Polarizer #TIP()	108.95	159.95	300.95	314.95	300.95	301.95	301.95
Warm Linear Polarizer #TIWP()	126.95	167.95	322.95	350.95	337.95	350.95	350.95
Low-Light Polarizer #TILLP()	108.95	159.95	300.95	314.95	300.95	301.95	301.95
Warm Low-Light Polarizer #TIWLLP()	126.95	167.95	322.95	350.95	337.95	350.95	350.95
Ultra Pol Circular Polarizer #TIUCP()	216.95	253.95	387.95	425.95	414.95	425.95	425.95
Warm Ultra Pol Circular Polarizer #TIWUCP()	241.95	291.95	416.95	470.95	442.95	472.95	472.95
Ultra Pol Linear Polarizer #TIUP()	154.95	177.95	307.95	354.95	340.95	340.95	340.95
Warm Ultra Pol Linear Polarizer #TIWUP()	162.95	204.95	327.95	394.95	372.95	396.95	396.95

ND filters are available in densities of .1, .2, .3, .4, .5, .6, .7, .8, .9, 1.0, and 1.2. ND White Water Glass filters are available in densities of .3, .6, .9, and 1.2.

To order **ND** filters, put a * in the first parenthesis and the shade size in the second parenthesis. To order **Polarizer** filters, put the shade size in the parenthesis.

Shade size is put in as follows: 3" x 3" (33), 4" x 4" (44), 4" x 5.65" (45P), 5" x 6" (56), 5" x 5" (55Q), 5.65" x 5.65" (565), and 6.6" x 6.6" (66).

FILTERS

Smoque

The Smoque filter produces a smoke-like effect without the cost and hassle of smoke generators or the smoke that they create. Now you can easily create enhanced realism when shooting in places where smoke is normally encountered, like a nightclub or the scene of a fire.

Available in 4 grades, these filters can create the look alone, or in addition to a more modest application of real smoke. They allow greater base level consistency especially outdoors in a wind, and you don't have to wait for it to settle or to be replenished, as with real smoke. Make the shot while you make your talent and crew more comfortable.



Without Filter



With Smoque 4 Filter

Pro-Mist

Knocks the edge off sharpness, subtly flares highlights providing an almost "halo-like" glow, with a mild reduction in contrast. Great for most subjects where depicting raw harsh reality is not desirable. Warm Pro-Mist combines the Pro-Mist with the 812 filter, to tone down excessive sharpness, while adding warmth to the scene. It balances contrasting skin tones within one scene. Black Pro-Mist offers image softening with more subtle flare than an equivalent graded Pro-Mist. Warm Black Pro-Mist combines the Black Pro-Mist with the 812 filter, to soften the image with subtle flare, while adding warmth.

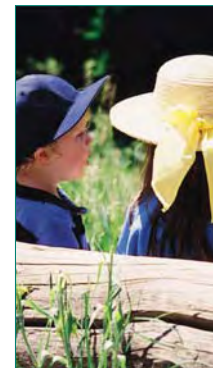

Without Filter



With Pro-Mist 2



Without Filter



With Sepia 2 Filter

Sepia

Often, when color isn't interesting enough, the best thing to do is to "warm it up" like photographers did early in the past century. Sepia filters enhance reality, adding a touch of subtlety or drama to the image. The Sepia #1 filter offers a mild brownish warmth. Both Sepia #2 and Sepia #3 offer a stronger brown tone, but Sepia #3 also includes a fog effect that softens and flares highlights. This combination comes in useful for portraits, "period" scenes, and many other situations.

PRO-MIST, SEPIA AND SMOQUE FILTERS

	3" x 3"	4" x 4"	4" x 5.65"	5" x 6"	5" x 5"	5.65" x 5.65"	6.6" x 6.6"
Pro Mist #TIPM() ()	135.95	199.95	327.95	417.95	373.95	417.95	417.95
Warm Pro Mist #TIWPM() ()	135.95	199.95	327.95	417.95	373.95	417.95	417.95
Black Pro Mist #TIBPM() ()	135.95	199.95	327.95	417.95	373.95	417.95	417.95
Warm Black Pro Mist #TIWBPM() ()	135.95	199.95	327.95	417.95	373.95	417.95	417.95
Sepia 1 #TIS1()	113.95	171.95	327.95	417.95	373.95	417.95	417.95
Sepia 2 #TIS2()	113.95	171.95	274.95	350.95	315.95	351.95	351.95
Sepia 3 #TIS3()	113.95	171.95	274.95	350.95	315.95	351.95	351.95
Smoque #TIS() ()	135.95	199.95	327.95	350.95	315.95	351.95	351.95

Pro Mist filters are available in densities of 1/8, 1/4, 1/2, 1, 2, 3, 4, and 5. Smoque filters are available in densities of 1, 2, 3, and 4.

To order Pro Mist and Smoque filters, put the density in the first parenthesis and the shade size in the second parenthesis.

To order Sepia filters, just put the shade size in the parenthesis.

Density is put in as follows: 1/8 (18), 1/4 (14), 1/2 (12), 1 (1), 2 (2), 3 (3), 4 (4), and 5 (5).

Shade size is put in as follows: 3" x 3" (33), 4" x 4" (44), 4" x 5.65" (45P), 5" x 6" (56), 5" x 5" (55Q), 5.65" x 5.65" (565), and 6.6" x 6.6" (66).

FILTERS

Softnet Filters

Often used in the early "Glamour" days to create the flawless faces of the Stars, a modern update made of special fine net laminated between clear optical glass. Softnet Black is the standard. Softnet White also softens contrast.

Soft/FX Filters

Long the standard for portraits and close-ups, Soft/FX has tiny lenslets embedded in the glass to provide a strong detail-hiding effect when it's needed. They can modestly flare highlights, and do a great job on diminishing fine details, yet leaves the overall appearance in-focus. Available in several grades. Warm Soft/FX combines the Soft/FX filter with 812 filter. Softens unwanted details while adding warmth and balance to skintones.



Without Filter



With Soft/FX

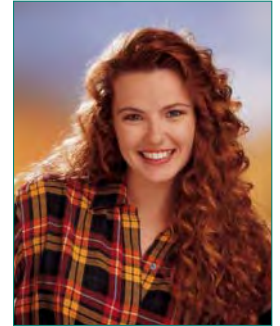

With Warm Soft/FX

SOFTNET & SOFT/FX FILTERS

	3" x 3"	4" x 4"	4" x 5.65"	5" x 6"	5" x 5"	5.65" x 5.65"	6.6" x 6.6"
Softnet Black #TISNB()()	113.95	171.95	274.95	351.95	314.95	351.95	351.95
Softnet White #TISCNW()()	113.95	171.95	274.95	351.95	314.95	351.95	351.95
Soft/FX #TISFX()()	135.95	199.95	327.95	417.95	373.95	417.95	417.95
Warm Soft/FX #TIWSFX()()	135.95	199.95	327.95	417.95	373.95	417.95	417.95



Tropic Blue 1



Cranberry 3



Grape 2



Tangerine 3

Solid Color FX Filters

Solid Color FX filters are a variety of solid-color versions of Tiffen's Color-Grad colors. They provide subtle or strong color for creating many special effects, giving you the ability to add more "punch" to an otherwise ordinary scene.

SOLID COLOR FX FILTERS

	3" x 3"	4" x 4"	4" x 5.65"	5" x 6"	5" x 5"	5.65" x 5.65"	6.6" x 6.6"
Antique Suede #TIAS()()	157.95	209.95	331.95	351.95	388.95	443.95	443.95
Chocolate #TICH()()	157.95	209.95	331.95	351.95	388.95	443.95	443.95
Cranberry #TICR()()	157.95	209.95	331.95	351.95	388.95	443.95	443.95
Gold #TIG()()	157.95	209.95	331.95	351.95	388.95	443.95	443.95
Grape #TIGP()()	157.95	209.95	331.95	351.95	388.95	443.95	443.95
Plum #TIPL()()	157.95	209.95	331.95	351.95	388.95	443.95	443.95
Straw #TIST()()	157.95	209.95	331.95	351.95	388.95	443.95	443.95
Tangerine #TIT()()	157.95	209.95	331.95	351.95	388.95	443.95	443.95
Tobacco #TITO()()	157.95	209.95	331.95	351.95	388.95	443.95	443.95
Tropic Blue #TITB()()	157.95	209.95	331.95	351.95	388.95	443.95	443.95

Softnet and Soft/FX filters are available in densities of 1, 2, 3, and 4. Solid Color FX filters are available in densities of 1, 2, and 3.

To order, put the density in the first parenthesis and the shade size in the second parenthesis. Density is entered as follows: 1 (1), 2 (2), and 3 (3).

Shade size is entered in as follows: 3" x 3" (33), 4" x 4" (44), 4" x 5.65" (45P), 5" x 6" (56), 5" x 5" (55Q), 5.65" x 5.65" (565), and 6.6" x 6.6" (66).

FILTERS

Special FX Filters

Digital Diffusion/FX filters make people look great without evidence of filtration; HDTV/FX



filters address contrast and sharpness issues

associated with HD; and Nude/FX is a series of filters that offers the ultimate flexibility and control in shooting skin tones.



With Nude/FX 1



With Nude/FX 2



With Nude/FX 3



With Nude/FX 6

SPECIAL FX FILTERS

	3" x 3"	4" x 4"	4" x 5.65"	5" x 6"	5" x 5"	5.65" x 5.65"	6.6" x 6.6"
Digital Diffusion/FX #TIDDFX() ()	155.95	232.95	376.95	479.95	428.95	481.95	481.95
HDTV/FX #TIHDTVFX() ()	155.95	232.95	376.95	479.95	428.95	481.95	481.95
Nude/FX #TINFX() ()	85.95	146.95	207.95	265.95	236.95	294.95	294.95

Digital/FX and HDTV/FX filters are available in densities of 1/4, 1/2, 1, 2, 3, 4, and 5. Nude/FX filters are available in densities of 1, 2, 3, 4, 5, and 6. To order, put a * in the first parenthesis and the shade size in the second parenthesis.



With Vector Star



With Hyper Star



With North Star

Star/Streak Effect Filters

Star filters make the most interesting use of lights in a scene. Turns points of light, either from reflections, bulbs, candles, etc. into sparkling starlike patterns. Use either the standard 4 or 6 point star, or try the more unusual Vector Star, an eight point star with lines at asymmetrical angles, for an even more exciting effect. Make street lights, holiday lights and most things shiny gleam! The Star filter is made of clear optical glass, which contains lines engraved on the glass surface, forming grid patterns. The

closer the line spacing in the pattern, the stronger the star effect. A 2mm grid produces a strong-lined star. The 3mm and 4mm grids are more subtle, yet produce finely outlined stars. The 3mm grid offers a slightly broader star than the 4mm grid. The Vector Star, Hyper Star, Hollywood Star and North Star have asymmetrical designs with lines of different brightness, for a more natural effect. They are often great in combination. Streak Effect is a special Star effect, producing a straight line of light running through the source.

STAR/STREAK EFFECT FILTERS

	3" x 3"	4" x 4"	4" x 5.65"	5" x 6"	5" x 5"	5.65" x 5.65"	6.6" x 6.6"
Star 4-Point #TIS4P() ()	174.95	199.95	306.95	424.95	365.95	424.95	424.95
Star 6-Point #TIS6P() ()	174.95	199.95	306.95	424.95	365.95	424.95	424.95
Vector Star #TIVS()	174.95	199.95	306.95	424.95	365.95	424.95	424.95
North Star #TINS()	174.95	199.95	306.95	424.95	365.95	424.95	424.95
Hollywood Star #TIHWS()	174.95	199.95	306.95	424.95	365.95	424.95	424.95
Hyper Star #TIHS()	174.95	199.95	306.95	424.95	365.95	424.95	424.95
Streak #TIS() () Q	174.95	199.95	306.95	424.95	365.95	424.95	424.95

Star 4-Point and 6-Point filters are available in 2mm, 3mm, and 4mm grids. Streak filters are available in 1mm, 2mm, and 3mm grids. To order Star 4-Point, Star 6-Point and Streak filters, put a * in the first parenthesis and the shade size in the second parenthesis. To order all other Star filters, just put the shade size in the parenthesis.

FILTERS

Standard Colors

A wide array colors for the most comprehensive image control. Sky-1A is pink-tinted for added warmth and better colors, and reduces the bluish cast of daylight to produce a pleasing, warmer picture tone. The UV-15 absorbs approximately 81% of UV rays, UV-17 absorbs approximately 97% of UV rays, and Warm UV-17 combines the UV-17 and the 812 Warming filter. UV Haze filters reduce excessive blue by absorbing UV light. 80 Series filters correct the lighting when shooting indoors with tungsten lighting. 81 Series filters are useful in cool light conditions. 82 Series filters reduce unnatural red tones in early morning or late afternoon light. 85 Series filters produce natural colors when shooting outdoors.



Without Filter

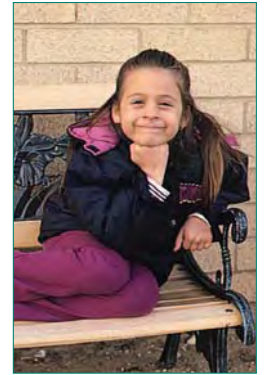

With 85B Filter

STANDARD COLOR FILTERS							
	3" x 3"	4" x 4"	4" x 5.65"	5" x 6"	5" x 5"	5.65" x 5.65"	6.6" x 6.6"
Sky-1A #TISL()	91.95	146.95	207.95	312.95	261.95	312.95	312.95
UV15 #TIUV15()	91.95	146.95	207.95	312.95	261.95	312.95	312.95
UV16 #TIUV16()	91.95	146.95	207.95	312.95	261.95	312.95	312.95
UV17 #TIUV17()	91.95	146.95	207.95	312.95	261.95	312.95	312.95
Warm UV17 #TIWUV17()	91.95	146.95	207.95	312.95	261.95	312.95	312.95
UV Haze 1 #TIUV()	91.95	146.95	207.95	312.95	261.95	312.95	312.95
UV Haze 2A #TIUV2A()	91.95	146.95	207.95	312.95	261.95	312.95	312.95
80A #TI80A()	91.95	146.95	207.95	312.95	261.95	312.95	312.95
80B #TI80B()	91.95	146.95	207.95	312.95	261.95	312.95	312.95
80C #TI80C()	91.95	146.95	207.95	312.95	261.95	312.95	312.95
80D #TI80D()	91.95	146.95	207.95	312.95	261.95	312.95	312.95
812 #TI812()	91.95	146.95	207.95	312.95	261.95	312.95	312.95
81 #TI81()	91.95	146.95	207.95	312.95	261.95	312.95	312.95
81A #TI81A()	91.95	146.95	207.95	312.95	261.95	312.95	312.95
81B #TI81B()	91.95	146.95	207.95	312.95	261.95	312.95	312.95
81C #TI81C()	91.95	146.95	207.95	312.95	261.95	312.95	312.95
81D #TI81D()	91.95	146.95	207.95	312.95	261.95	312.95	312.95
81EF #TI81EF()	91.95	146.95	207.95	312.95	261.95	312.95	312.95
82 #TI82()	91.95	146.95	207.95	312.95	261.95	312.95	312.95
82A #TI82A()	91.95	146.95	207.95	312.95	261.95	312.95	312.95
82B #TI82B()	91.95	146.95	207.95	312.95	261.95	312.95	312.95
82C #TI82C()	91.95	146.95	207.95	312.95	261.95	312.95	312.95
85 #TI85()	91.95	146.95	207.95	312.95	261.95	312.95	312.95
85B #TI85B()	91.95	146.95	207.95	312.95	261.95	312.95	312.95
85C #TI85C()	91.95	146.95	207.95	312.95	261.95	312.95	312.95

To order **Standard Color Filters**, please fill in the parenthesis at the end of the SKU as follows: 3" x 3" (33), 4" x 4" (44), 4" x 5.65" (45P), 5" x 6" (56), 5" x 5" (55Q), 5.65" x 5.65" (565), and 6.6" x 6.6" (66).

FILTERS

DV and DV "Survival" Filter Kits

Create a new look with the "secret tools" of the movie industry. These kits take the guesswork out of which filter to use in a variety of shooting situations. These kits are designed primarily for professional shooters using prosumer DV cameras to produce results that are more pleasing, less harsh and less brassy. The three DV "Survival" Kits are designed for those looking for richer, more vibrant color saturation, improved contrast, crowd pleasing skin tones, spectacular landscapes, and exciting special effects. Filters are packed in individual pouches and each kit includes a multi-compartment bag and shoulder strap.



DV Filter Kits

4x4" Video Essentials DV Kit:

Includes a Clear filter to protect your valuable lens from dirt, scratches, grime, and damage without any color or exposure change to the subject; a Circular Polarizer to increase color saturation; a Warm UV 17, which removes 97% of the ultra violet light, and a 4-pocket filter pouch.

(Mfr # 44DVVEK • B&H # TIVEDVK44)439.95

4x4" "Film-Look" DV Kit:

Includes a Black Diffusion FX 1/2 for a silky-smooth look to textured surfaces, Warm Black Diffusion FX 1/4, which is the same as the Black Diffusion/FX with the added warmth of an 812 filter, Black Pro-Mist 1/2 to tone down excessive sharpness, Soft/FX 1 to soften unwanted details, and 4-pocket filter pouch.

(Mfr # 45650DVFLK • B&H # TIFLDVK45.65).....989.50

4x4" Special Effects DV Kit:

Includes Color Grad ND 0.6 which balances sky to foreground, Pro-Mist 1/4 which tones down excessive sharpness and reduces contrast, Enhancing filter which makes reds, rust browns and oranges "pop", Gold Diffusion FX 1/2 for a silky smooth look and a warm, gold tone; and a 4-pocket filter pouch.

(Mfr # 44DVSEK • B&H # TISEDVK44)799.95

DV "Survival" Filter Kits

DV Essentials Kit 3: Includes a Clear, an 812, and an Ultra Pol Circular Polarizer filter. The Clear filter offers optimum protection of your lens; 812 filter reduces cool blue tones of outdoor scenes and video lights and warms up a variety of skintones for a healthier look; Ultra Pol Circular Polarizer deepens blue skies against white puffy clouds on sunny days for eye-catching cloud contrast, reduces maximum undesirable glare and reflections from non-metallic surfaces, and increases significant color saturation resulting in overall richer, more vibrant color.

4x4" DV Essentials Kit 3 (TIDVEK344)432.00

4x5.65" DV Essentials Kit 3 (TIDVEK345P).....582.30

6.6x6.6" DV Essentials Kit 3 (TIDVEK36.6).....765.90

DV Select Kit 3: Includes a Neutral Density 0.6, a Black Pro-Mist 1/4 and an Ultra Pol Circular Polarizer. The Neutral Density 0.6 effectively reduces the amount of light passing through camera lens without changing the color of the scene. Black Pro-Mist 1/4 produces a subtle reduction of the very high, slightly harsh contrast produced by DV. It tones down excessive sharpness to create a "film look", and smoothes and softens unwanted fine detail like wrinkles and blemishes.

4x4" DV Select Kit 3 (TIDVSK344).....501.30

4x5.65" DV Select Kit 3 (TIDVSK345P).....696.60

6.6x6.6" DV Select Kit 3 (TIDVSK36.6).....905.40

DV Scenic Enhancing Kit 3: Sunset Color-Grad 2 adds vibrant red to orange to yellow to clear graduated color to background without affecting foreground. Enhancing filter creates warm vibrant color by selectively improving and super-saturating reds, oranges, rust browns and wood tones with minimum effect on other colors. Color-Grad ND. 6 cuts down two stops of light in the background while maintaining foreground light, bringing both into proper exposure balance.

4x4" DV Scenic Enhancing Kit 3 (TIDVSEK344)594.00

4x5.65" DV Scenic Enhancing Kit 3 (TIDVSEK345P).....819.00

6.6x6.6" DV Scenic Enhancing Kit 3 (TIDVSEK36.6)1082.70

DV "Film-Look" Kit 3: Digital Diffusion/FX 1 creates a silky smooth look on textured surfaces and suppresses facial blemishes and wrinkles. Soft/FX 1 produces slightly more reduction in contrast than the Digital Diffusion/FX, for a classic "film-look" on DV. Black Pro-Mist 1/2 creates traditional full blown "film-look" on DV, and offers more reduction in contrast.

4x4" DV "Film-Look" Kit 3 (TIDVFLK344)513.00

4x5.65" DV "Film-Look" Kit 3 (TIDVFLK345P)757.80

6.6x6.6" DV "Film-Look" Kit 3 (TIDVFLK36.6)1024.20

Scene Makers Kit: Includes Ultra Pol Circular Polarizer, Cool Day-For-Night to create the look of night during the day; 812 Warming to reduce cool blue tones of outdoor scenes and video lights and warm up a variety of skintones.

4x4" Scene Makers Kit (T1442USMK1).....425.70

4x5.65" Scene Makers Kit (T12USMK14565)807.30